

INSTALLATION INSTRUCTIONS

*The vessel and faucet set is not included

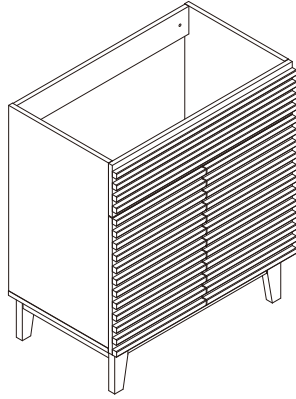

ASSEMBLY DIAGRAM

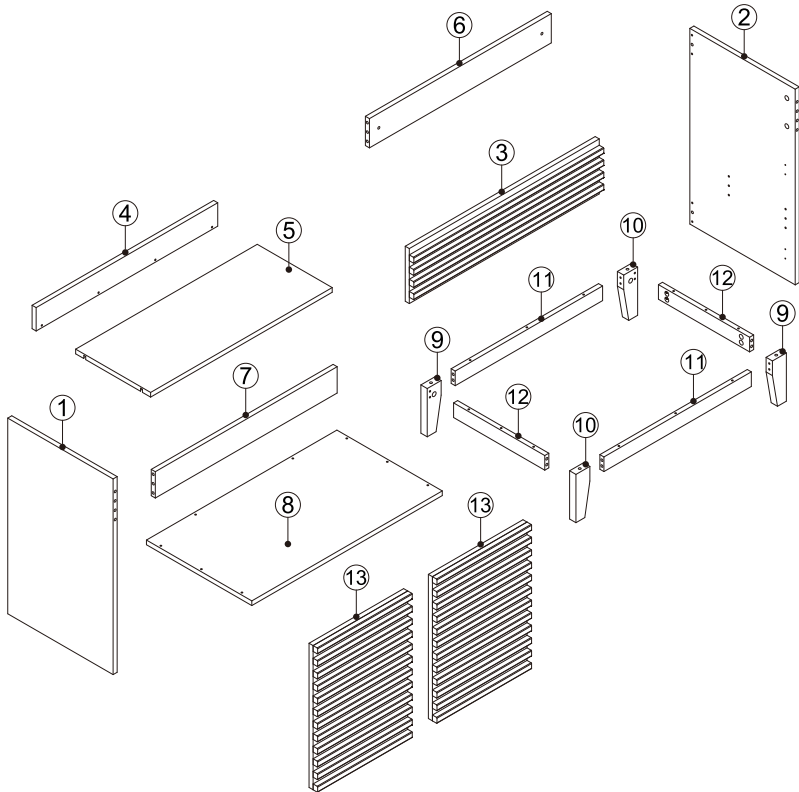

YOU MAY NEED (NOT SUPPLIED)

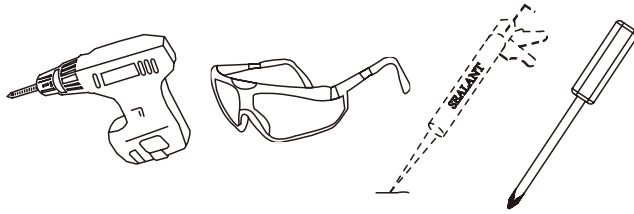

INSTALLATIONS

STEP 1

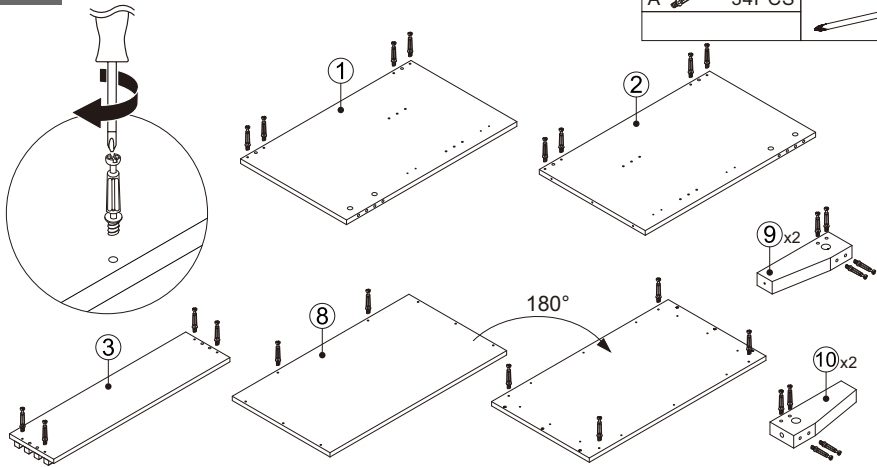

- Insert the Cam Screw into the shelves above.

STEP 2

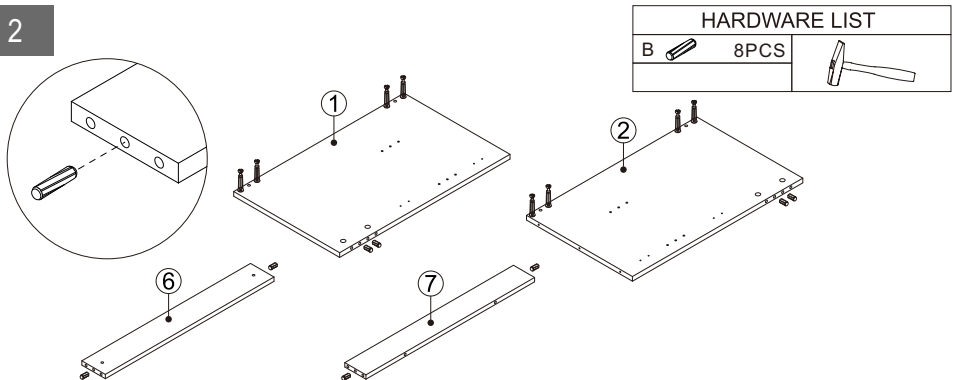

- Insert the wooden dowel pins into the shelves.

STEP 3

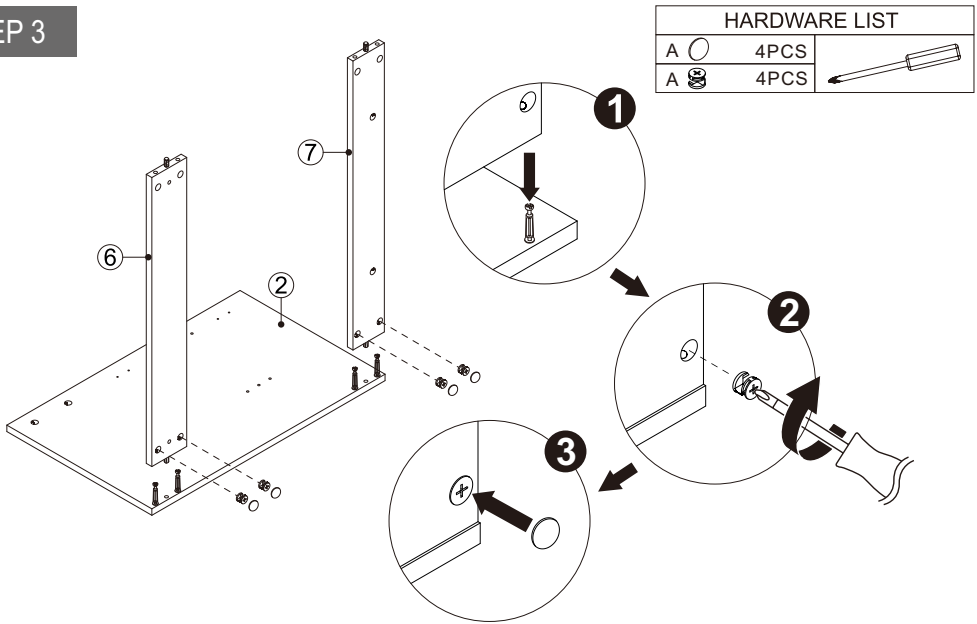

- Insert shelves #6,#7 and #2 downwards to their corresponding positions. Then tighten the cam lock with the cover.

STEP 4

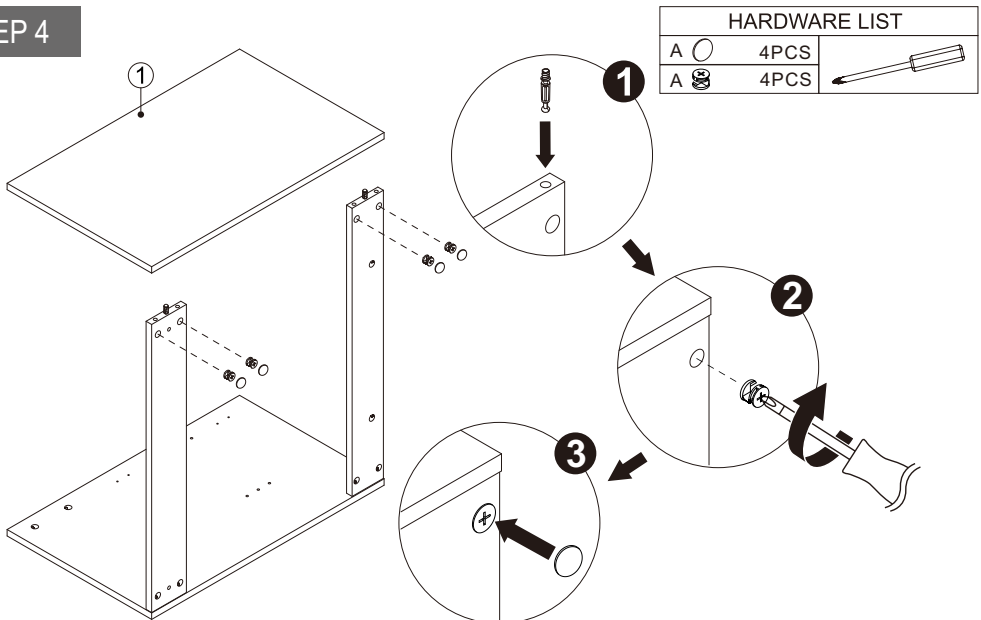

- Refer to the illustration, Install shelf #1 on the cabinet. Then tighten the cam lock with the cover.

STEP 5

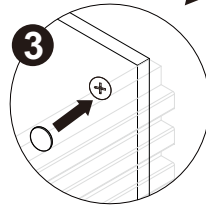
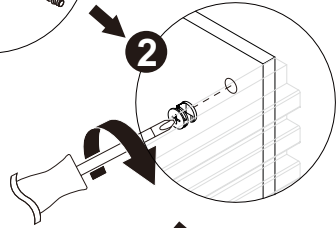
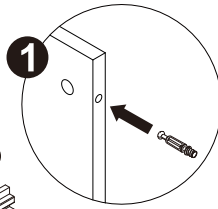
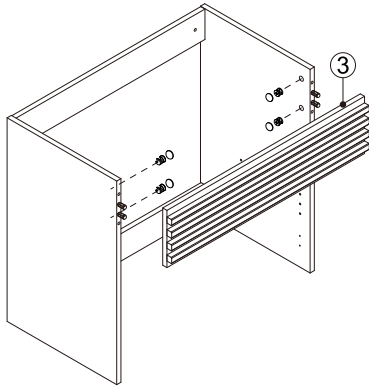

HARDWARE LIST		
A		4PCS
A		4PCS

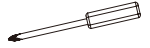

- Refer to the illustration, insert the #3 into the assembled shelf as well. Then tighten the cam lock with the cover.

STEP 6

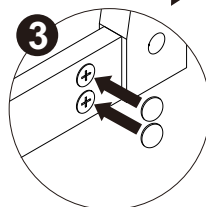
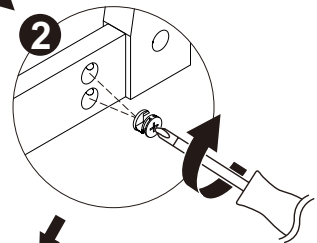
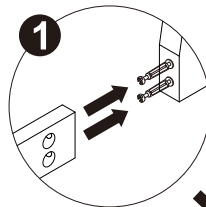
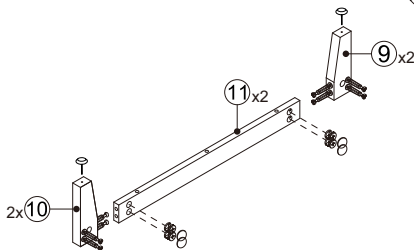

HARDWARE LIST		
A		22PCS
A		22PCS
D		4PCS
G		18PCS

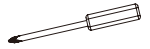

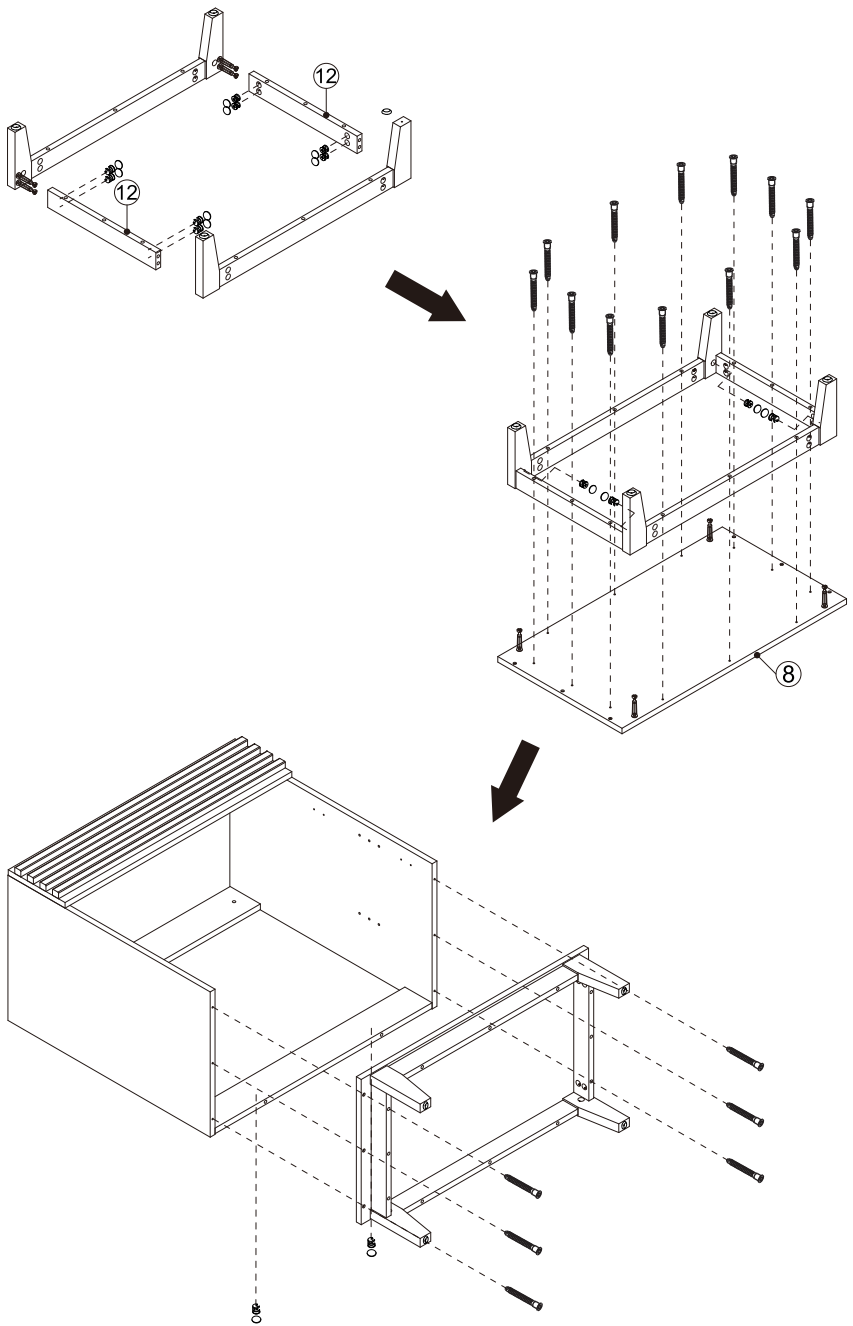

- Connect the shelf #9,#10,#11,#12 together,Then tighten the cam lock with the cover. connect the assembled shelf with #8 with screws,and then connect the cabinet with the assembled feet with screws. Then tighten the cam lock with the cover.

STEP 7

HARDWARE LIST		
C		8PCS
E		4PCS

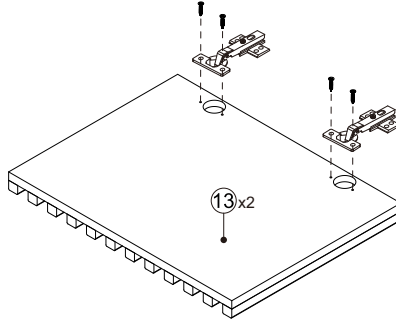



Note: see step 8 to adjust the door's position.

- Use Screws to fix the hinge on the shelf #13.

STEP 8

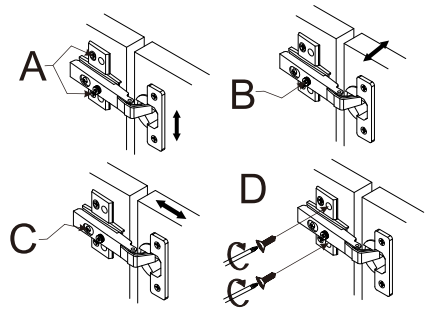
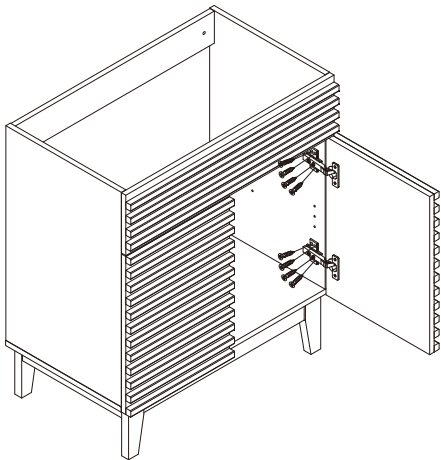
HARDWARE LIST		
C		16PCS

A.Height adjustment

B.Side to side adjustment

C.Depth adjustment

D.After adjustment A/B/C,tighten screws.

- To ensure proper cabinet alignment, refer to the above illustrations for instructions about adjusting the cabinet height, depth and lateral movement.

STEP 9

HARDWARE LIST		
G		4PCS
		

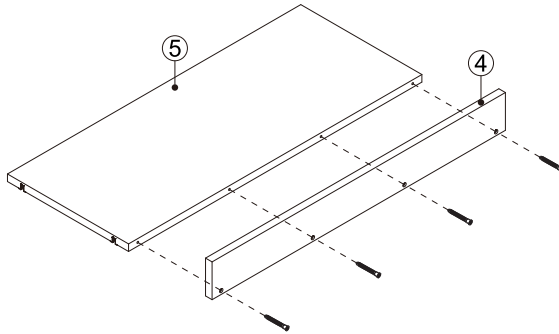

- Use screws connect the shelf #4,#5 together.

STEP 10

HARDWARE LIST		
H		4PCS
		

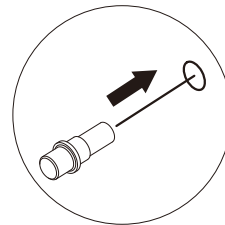
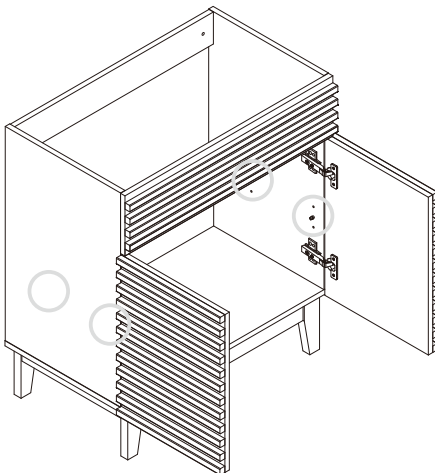

- Refer to the illustration,insert the shelf braket into the corresponding holes.

STEP 11

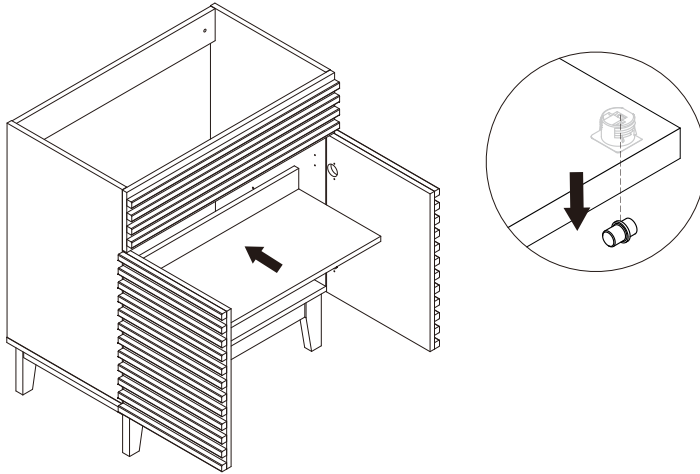

- Put the assembled shelves and insert the clasp into the shelf bracket.

STEP 12

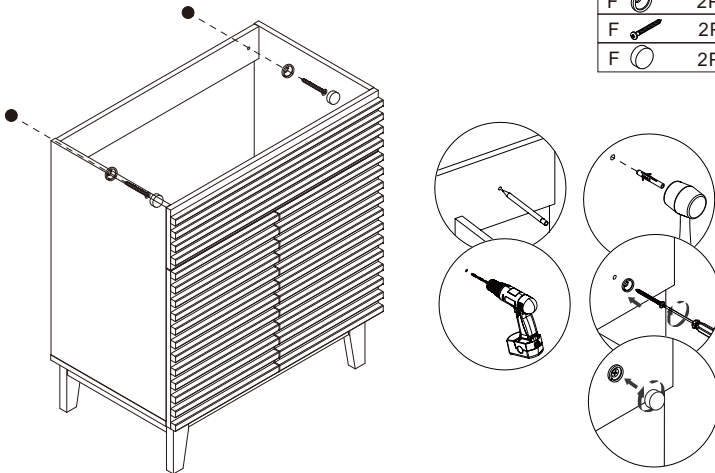

- Refer to the illustration, Draw the spacing between the walls on the cabinet, punch holes in the wall, and fix the cabinet to the wall with screws. Then tighten the nut cover.

STEP 13

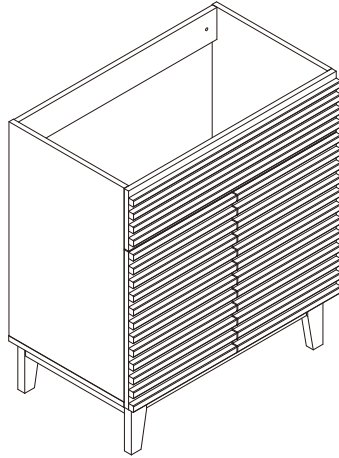

- To help prevent mildew, apply sealant to the space between the wall and the edge of the cabinet.

CARE AND CLEANING

1. Many cleansers contain abrasive and chemical substance which is not suitable for cleaning stainless steel, enamel, plating or plastic products. You may use mild cleansers or soaps to clean the surfaces. Wipe any splashes of cleaner solutions from the surface with a clean soft cloth.
2. Maintain ventilation in the bathroom and separate the dry area from the damp one if conditions permit. Try to open the door and windows of the bathroom to maintain adequate ventilation.
3. This cabinet is built to withstand normal bathroom humidity. For best results, keep this vanity dry and take necessary steps to minimize bathroom humidity by opening windows and doors and using the exhaust fan (if available).
4. To maintain the cabinet door, clean and wipe the door regularly with a soft cloth. Wipe condensation with a dry, soft cloth. Keep away from fires and high temperatures.
5. Please do not sit, lean or step on the basin cabinet.

FEEDBACK ★★★★★

Thank you very much for purchasing from us.

We have always been trying to provide the best service and reliable products for every customer.

We sincerely hope you will be satisfied with our products and leave us FIVE STARS and POSITIVE feedback/review in our page.

However, accident may happen sometimes, please contact us to resolve any issue before leaving a negative feedback.

Many thanks and welcome to our shop again!