

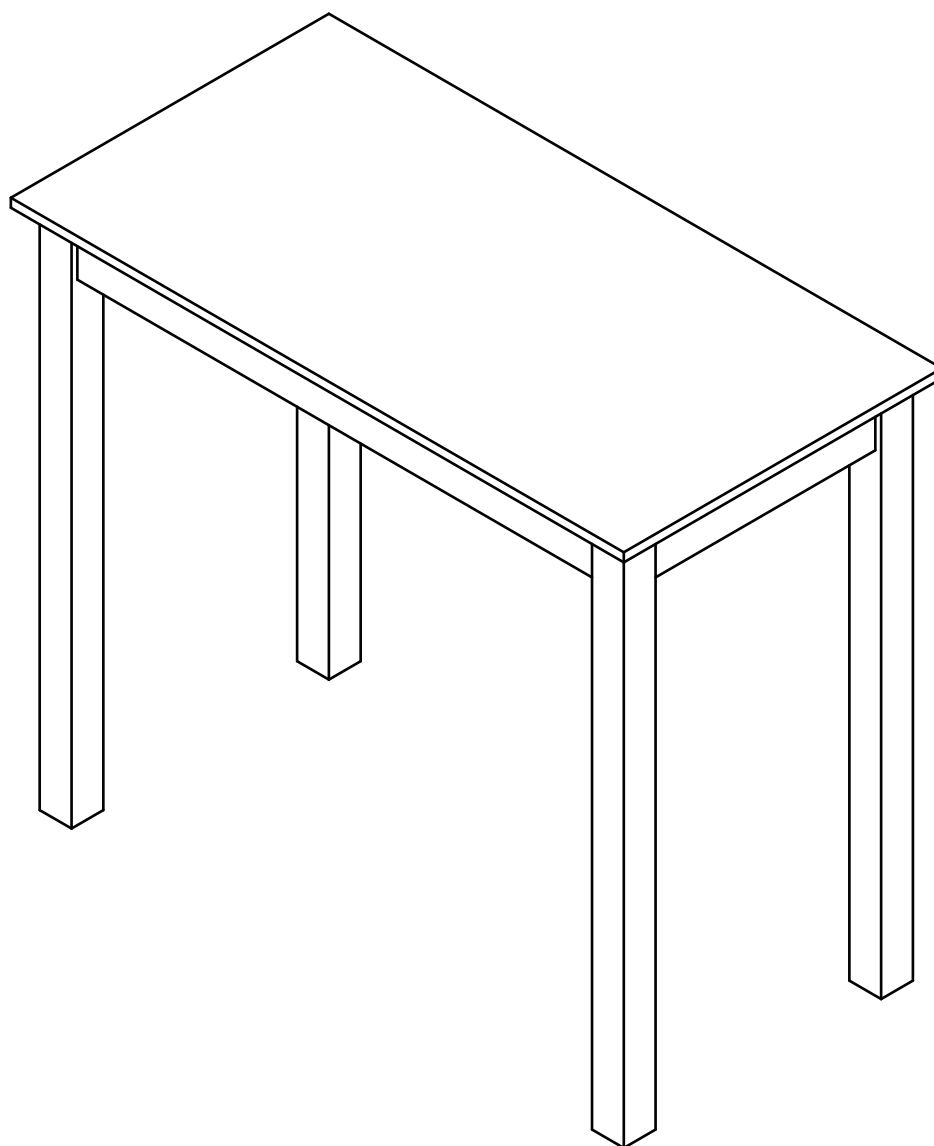

ASSEMBLY INSTRUCTIONS



Thank you for purchasing a Chair & Table Company product. This product has been designed for easy assembly and is constructed for durability. Please take the time to read and follow the assembly instructions carefully. If a part or hardware is missing or you have any difficulties in assembling this product, please contact us.





BEFORE ASSEMBLY

Be sure to check all packing material carefully for small parts which may have come loose inside the carton during shipment. Please separate, identify, and count all parts and metal hardware. Compare with part list to be sure all parts are present.

IMPORTANT NOTE:

- Place all parts on a clean and smooth surface such as a rug or carpet to prevent the parts from being scratched.
- Remove all wrapping material.
- DO NOT tighten all screws and bolts until assembly is completed.
- Keep all hardware parts out of reach of children.

ASSEMBLY TOOLS REQUIRED



Allen key 5mm (included)



PART LIST

When unpacking, please be careful not to discard any parts with the packaging. Before continuing, please make sure you have the following parts:

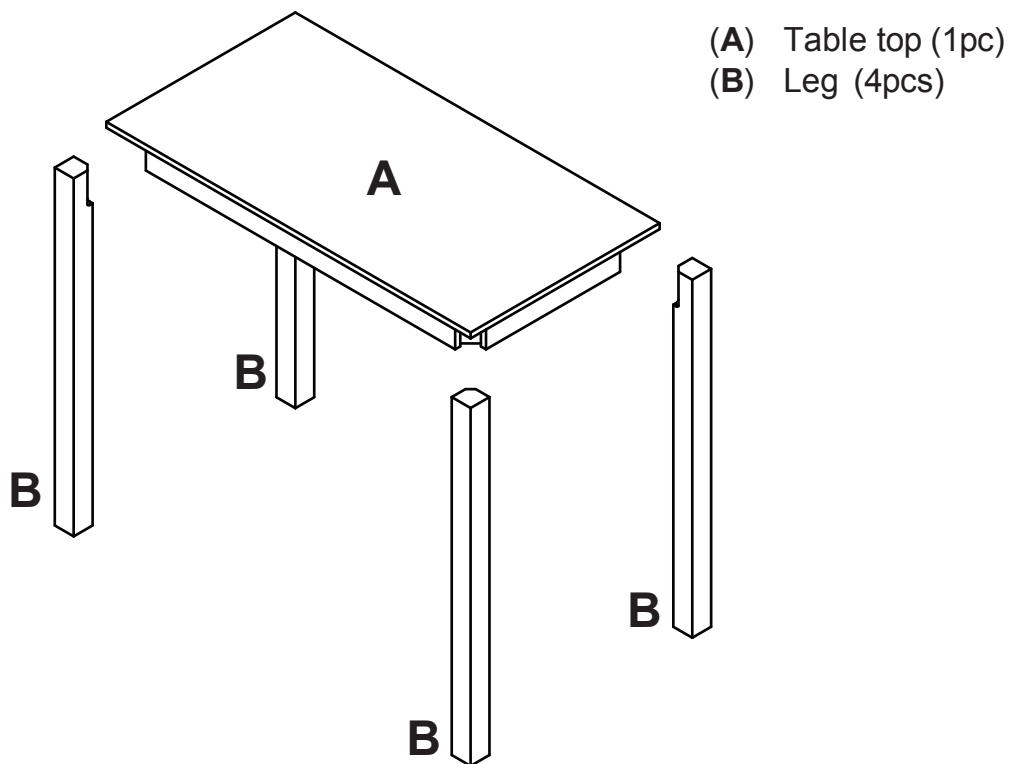

HARDWARE LIST

Before continuing, please make sure you have the following hardware.

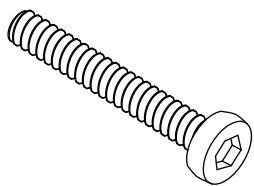

C
(8pcs)



D
(8pcs)



E
(8pcs)

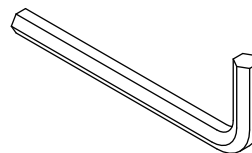

F
(1pc)

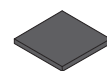

G
(4pcs)



DO NOT tighten all screws and bolts until assembly is completed.

Step 1

