

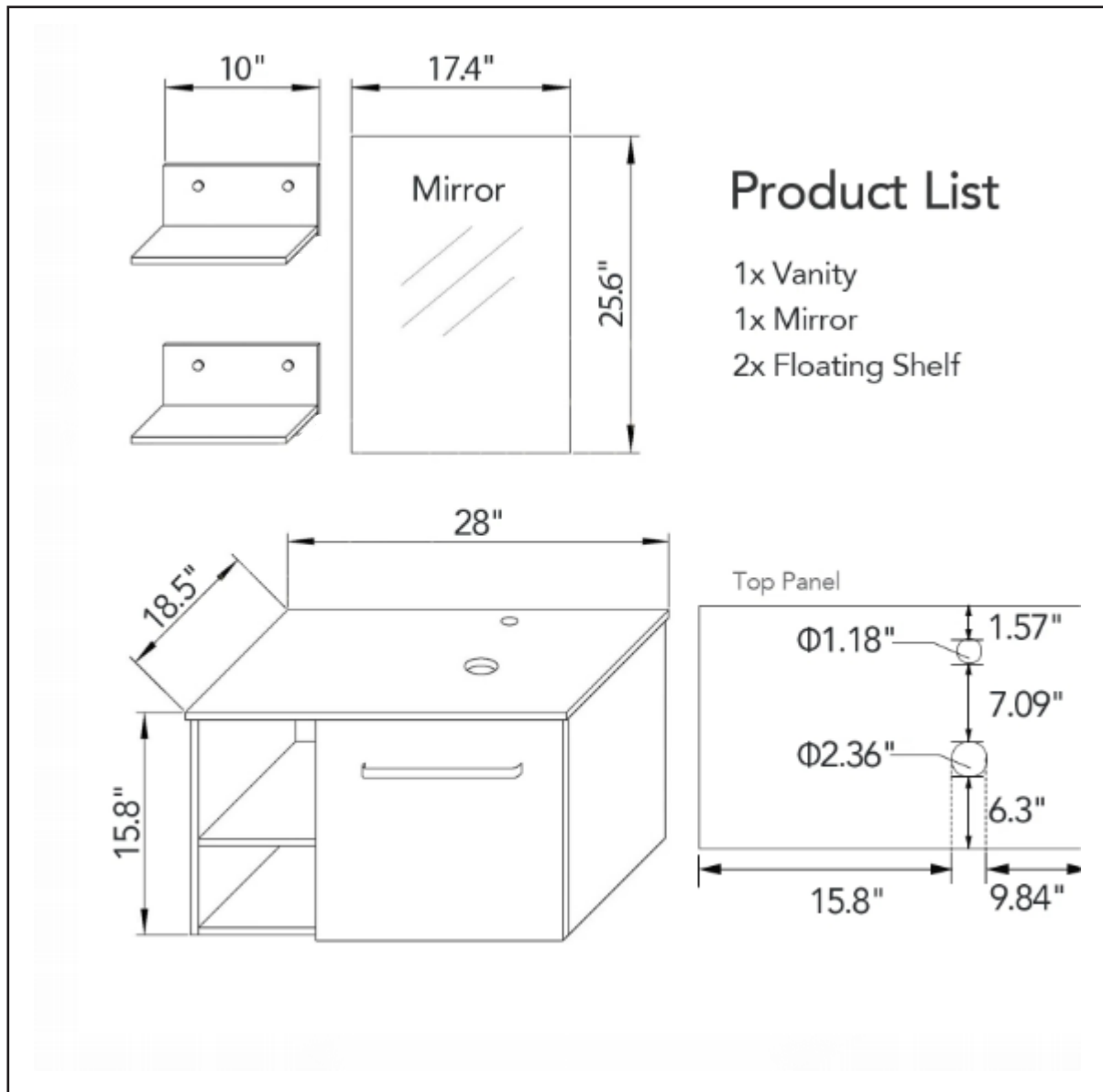









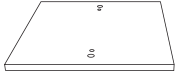

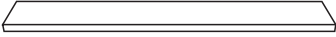









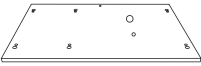
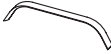

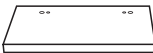

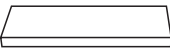
Assembly guide







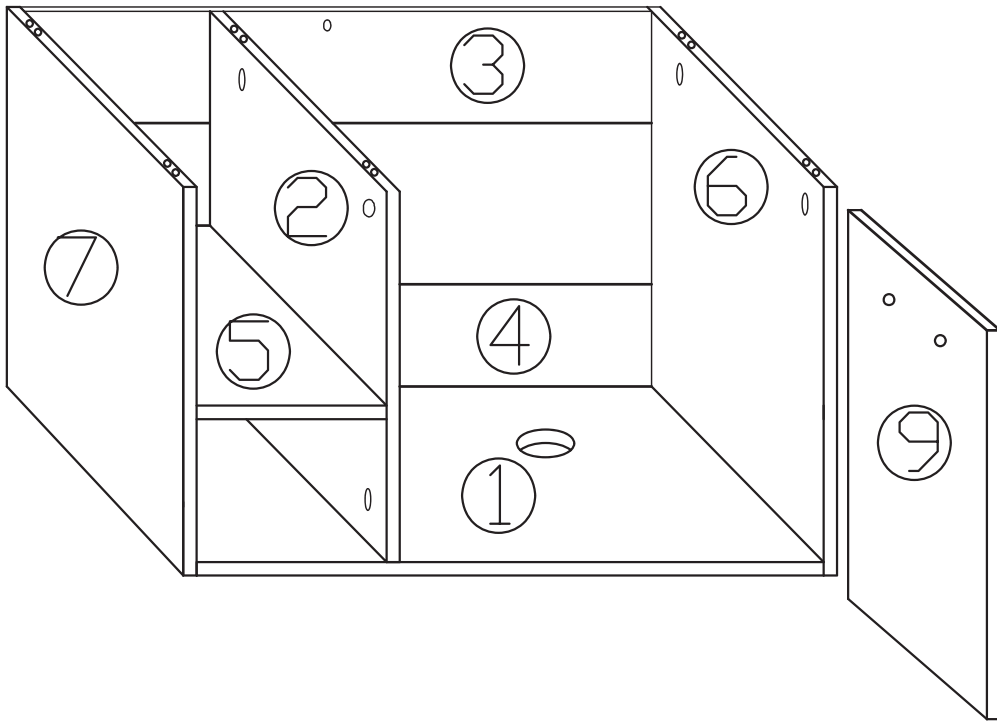
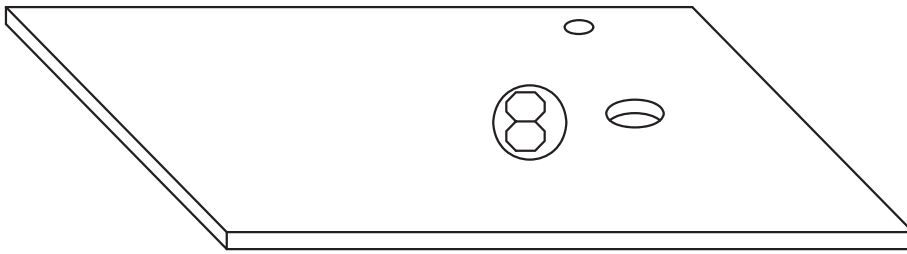
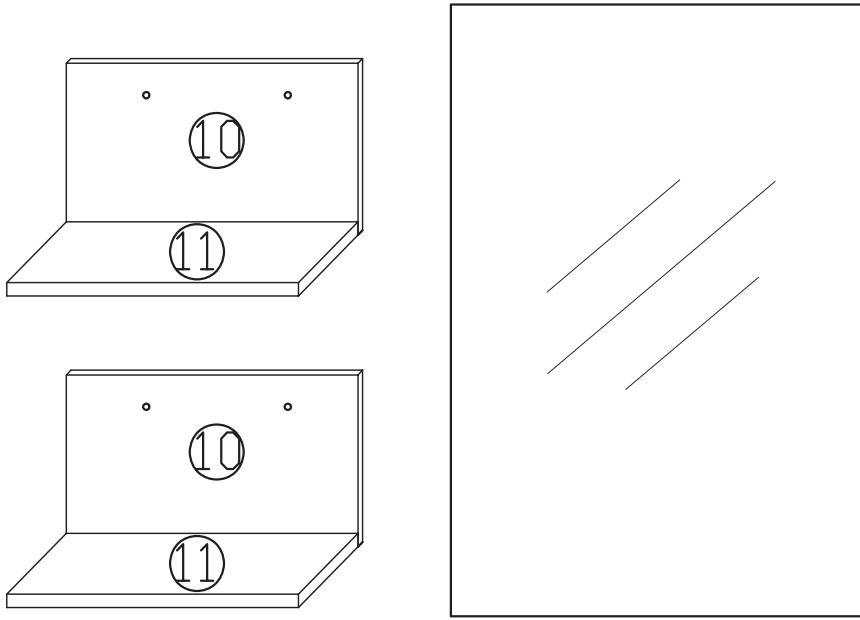

























Package list

Parts list			Hardware list		
NO.	Description	QTY	NO.	Description	QTY
1		1	A	 CAM LOCK	36
2		1	B	 CAM SCREW	36
3		1	C	 CAM LOCK COVER	36
4		1	D	 WOODEN DOWEL	20
5		1	E	 4x14mm SCREW	12
6		1	F	 HINGE	2
7		1	G	 4x18mm HANDLE SCREW	2
8		1	H	 HANDLE	1
9		1	I	 (ø4x35mm)	12
10		2	J	 (ø6x30mm)	12
11		2	K	 CABINET SUSPENSION	2
12		1	L	 FIXED BANK	2
			M	 M4X25MM SCREW	4
			N	 washer	4
			P	 cover	4
			Q	 BOTTOM DRAIN HOLE COVER	1





Installation Manuel

<p>step1</p>	<table border="1"> <thead> <tr> <th colspan="3">HARDWARE LIST</th> </tr> </thead> <tbody> <tr> <td>B</td> <td></td> <td>36</td> </tr> <tr> <td colspan="3" style="text-align: center;"></td> </tr> </tbody> </table>	HARDWARE LIST			B		36				<p>step2</p>	<table border="1"> <thead> <tr> <th colspan="3">HARDWARE LIST</th> </tr> </thead> <tbody> <tr> <td>D</td> <td></td> <td>20</td> </tr> <tr> <td colspan="3" style="text-align: center;"></td> </tr> </tbody> </table>	HARDWARE LIST			D		20									
HARDWARE LIST																											
B		36																									
																											
HARDWARE LIST																											
D		20																									
																											
<p>step3</p>	<table border="1"> <thead> <tr> <th colspan="3">HARDWARE LIST</th> </tr> </thead> <tbody> <tr> <td>A</td> <td></td> <td>2</td> </tr> <tr> <td>C</td> <td></td> <td>2</td> </tr> <tr> <td colspan="3" style="text-align: center;"></td> </tr> </tbody> </table>	HARDWARE LIST			A		2	C		2				<p>step4</p>	<table border="1"> <thead> <tr> <th colspan="3">HARDWARE LIST</th> </tr> </thead> <tbody> <tr> <td>A</td> <td></td> <td>8</td> </tr> <tr> <td>C</td> <td></td> <td>8</td> </tr> <tr> <td colspan="3" style="text-align: center;"></td> </tr> </tbody> </table>	HARDWARE LIST			A		8	C		8			
HARDWARE LIST																											
A		2																									
C		2																									
																											
HARDWARE LIST																											
A		8																									
C		8																									
																											



Installation Manuel

step5

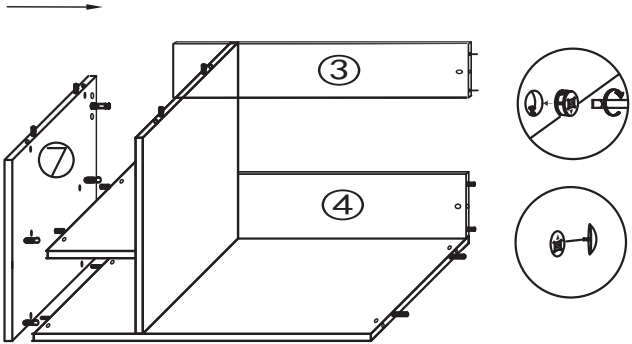
HARDWARE LIST		
A		8
C		8







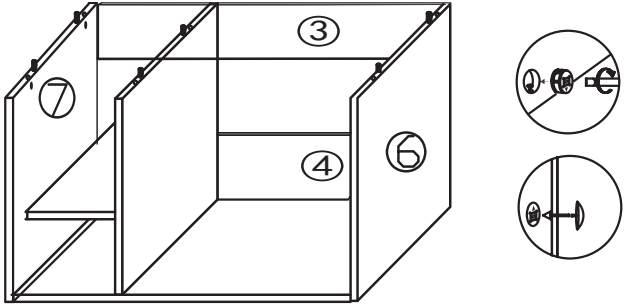

step6

HARDWARE LIST		
A		6
C		6







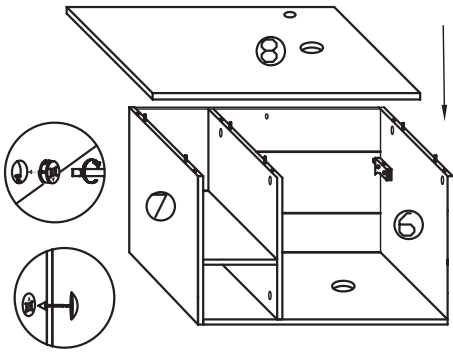

step7

HARDWARE LIST		
A		8
C		8
K		2
M		4



step8

HARDWARE LIST		
E		12
F		2
G		2
H		1

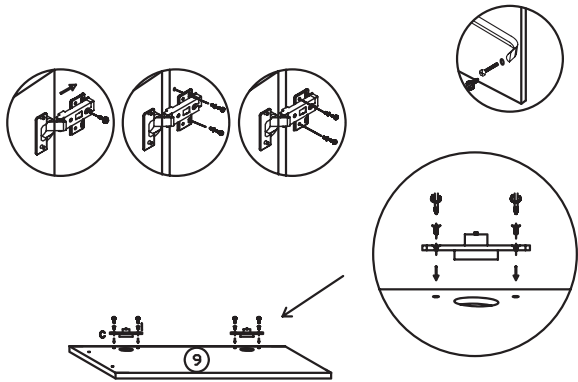



Installation Manuel

step9

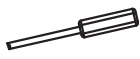
HARDWARE LIST		
A		4
C		4

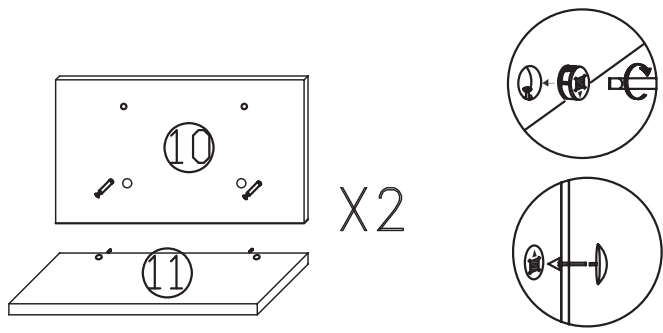



X2

step10

HARDWARE LIST		
J		12



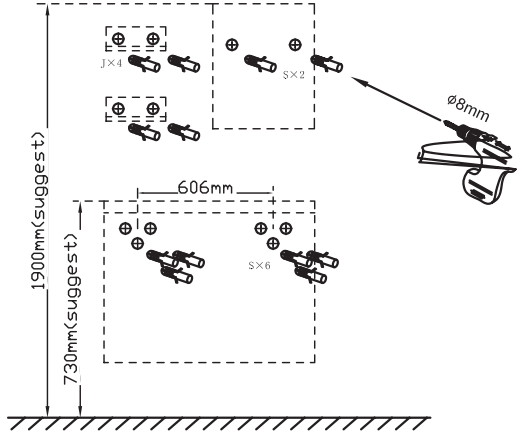



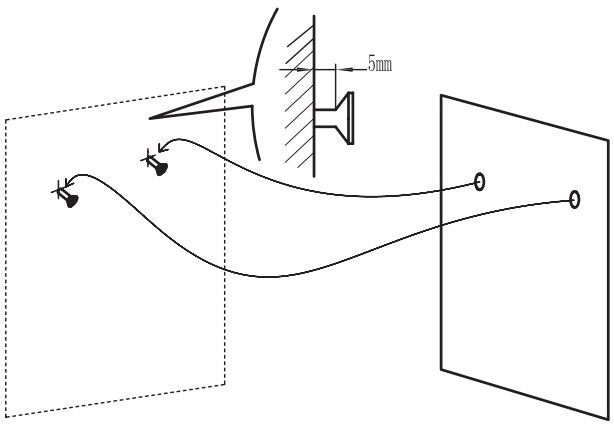

step11

HARDWARE LIST		
I		2





step12



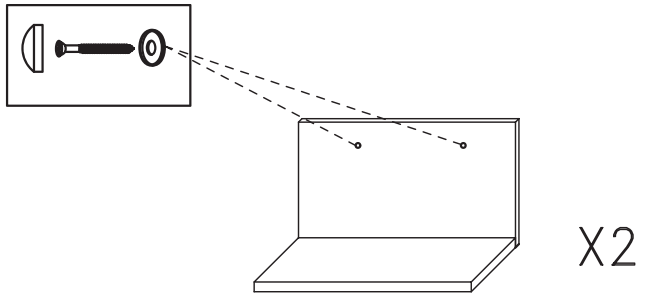

HARDWARE LIST		
I		4
P		4
N		4



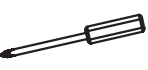
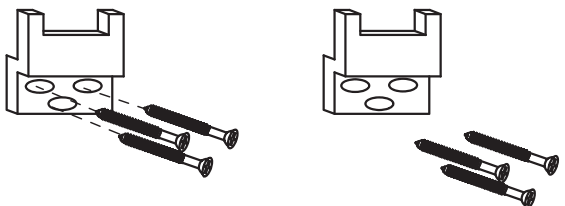

X2

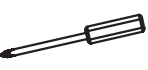
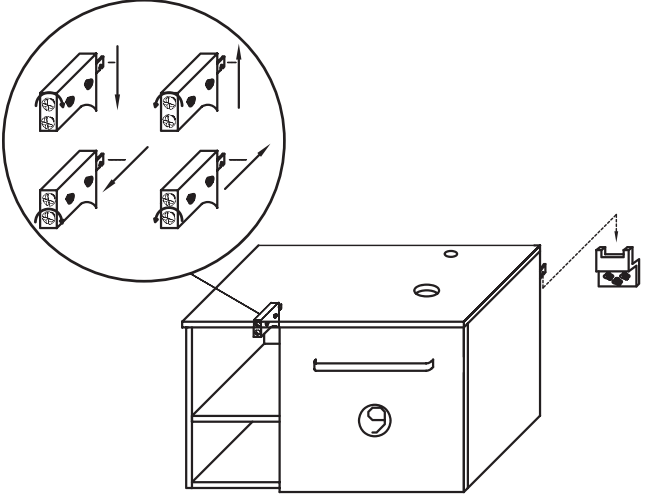
Installation Manuel

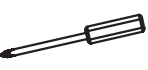
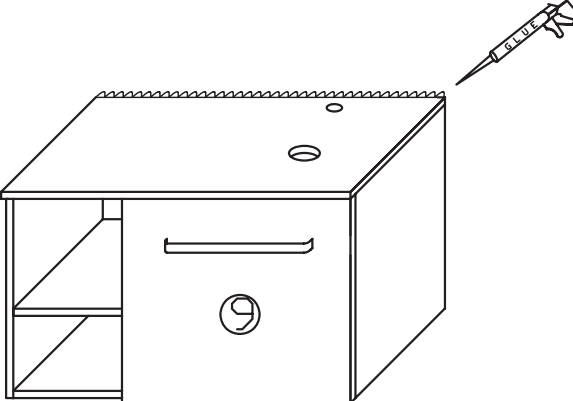
<p>step13</p> <table border="1" data-bbox="397 309 803 436"><thead><tr><th colspan="2">HARDWARE LIST</th></tr></thead><tbody><tr><td>I</td><td> 6</td></tr><tr><td></td><td></td></tr></tbody></table> 	HARDWARE LIST		I	 6			<p>step14</p> <table border="1" data-bbox="1112 309 1526 436"><thead><tr><th colspan="2">HARDWARE LIST</th></tr></thead><tbody><tr><td></td><td></td></tr><tr><td></td><td></td></tr></tbody></table> 	HARDWARE LIST					
HARDWARE LIST													
I	 6												
													
HARDWARE LIST													
<p>step15</p> <table border="1" data-bbox="397 1159 803 1285"><thead><tr><th colspan="2">HARDWARE LIST</th></tr></thead><tbody><tr><td></td><td></td></tr><tr><td></td><td></td></tr></tbody></table> 	HARDWARE LIST						<p>step16</p> <table border="1" data-bbox="1112 1159 1526 1285"><thead><tr><th colspan="2">HARDWARE LIST</th></tr></thead><tbody><tr><td></td><td></td></tr><tr><td></td><td></td></tr></tbody></table>	HARDWARE LIST					
HARDWARE LIST													
HARDWARE LIST													