

ASSEMBLY INSTRUCTIONS

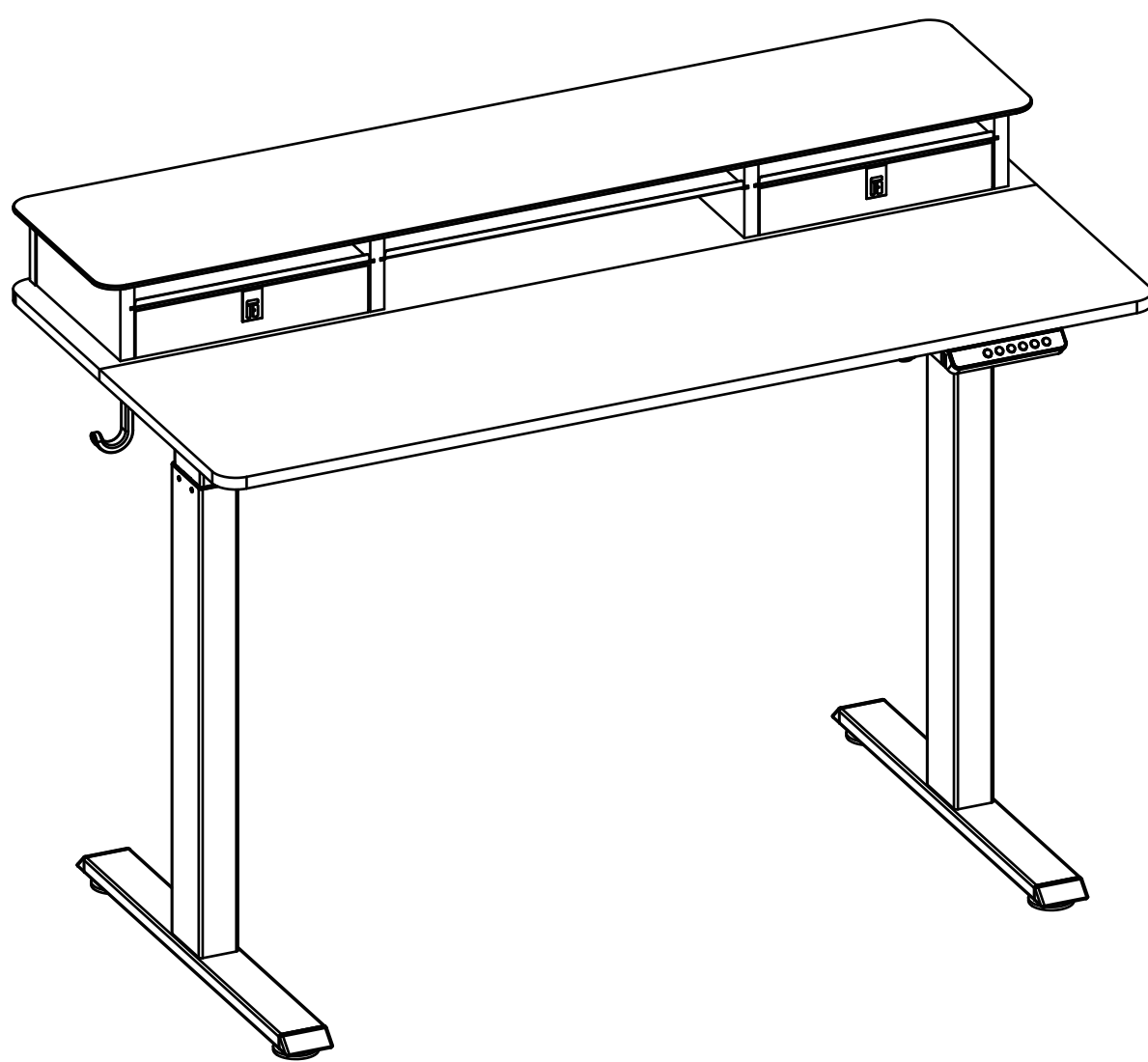

NOTES(技术要求):

1.Dimension after binding(装订后尺寸): 210*297mm.

2.Print colour(印刷颜色): 1C.

3.Coating(表面处理): 无.

4.Material(材质): 80g offset paper (80g双胶纸).

5.Binding process(装订工艺): Saddle stitch(骑马钉).

6.Output lpi(输出网线): 200 lpi.

7.Tolerance(公差): L(长)*W(宽): ± 1.5 mm.

8. 原材料及后处理工艺均需满足RoHS环保要求。

(Raw materials and the corresponding post processing should meet RoHS environmental protection requirements)

ASSEMBLY INSTRUCTIONS

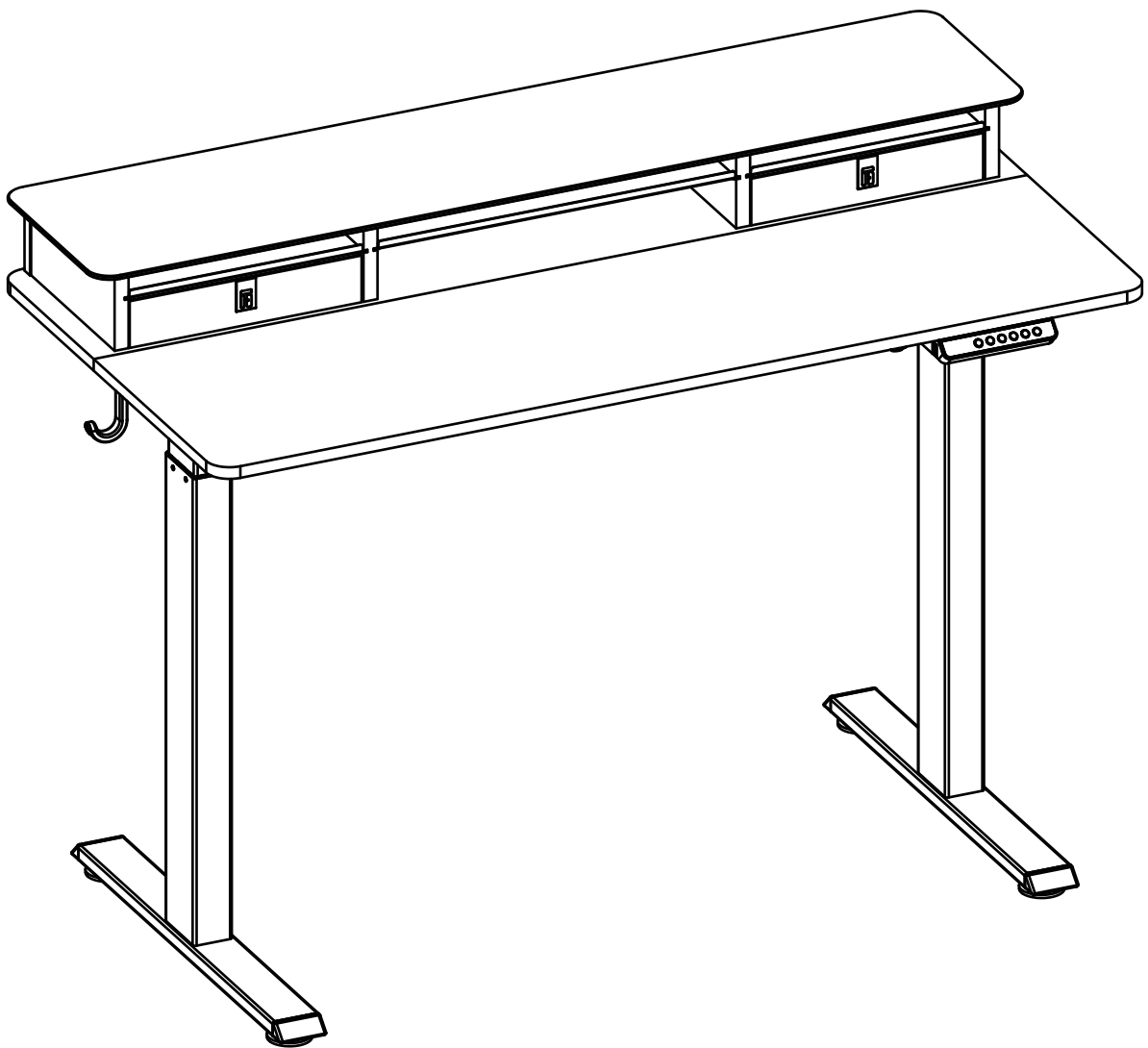

English

Caution

- Keep children and animals away from the desk during use. Ensure the desktop is not touching any walls.
- Remove obstacles taller than 20"/51 cm from underneath the desk.
- Operate only in a working environment temperature of 32°F-104°F/0°C-40°C.
- Keep product away from corrosive gases, liquids and dusty objects.
- Keep hands, feet and other body parts in a safe position during operation. Anti-collision is not automatically enabled during all resets.
- Please read the following instructions carefully before using the height-adjustable desk.
- The company does not bear any warranty or liability for damage and human injury caused by any abnormal or un-intended operation of the equipment.
- It is necessary to perform a manual reset after the initial installation or power cycling the equipment.

Español

Precaución

- Mantenga a los niños y animales alejados del escritorio durante su uso. Asegúrese de que el escritorio no toca ninguna pared.
- Retire aquellos obstáculos con una altura superior a 20"/51 cm de debajo del escritorio.
- Opérela únicamente en una temperatura del entorno de trabajo de 32°F-104°F/0°C-40°C.
- Mantenga el producto alejado de gases corrosivos, líquidos y objetos con polvo.
- Mantenga las manos, pies y otras partes del cuerpo en una posición segura durante el funcionamiento. No se habilita la anticollisión de forma automática tras los reinicios.
- La empresa no ofrece ninguna garantía ni asume ninguna responsabilidad por cualquier daño o lesión humana provocada por un funcionamiento anormal o no previsto del equipo.
- Es necesario realizar un reinicio manual tras la instalación inicial o el ciclo de encendido.

Italiano

Attenzione

- Tenere i bambini e gli animali lontani dalla scrivania durante l'uso. Assicurarsi che il piano non tocchi alcuna parete.
- Rimuovere gli ostacoli più alti di 20"/51 cm da sotto la scrivania.
- Operare solo in un ambiente di lavoro con una temperatura di 32°F-104°F/0°C-40°C.
- Tenere il prodotto lontano da gas e liquidi corrosivi e oggetti polverosi.
- Tenere mani, piedi e altre parti del corpo in posizione di sicurezza durante il funzionamento. L'anti-collisione non è automaticamente attivata dopo il ripristino.
- La società non si assume alcuna garanzia o responsabilità per danni e lesioni umane causati da un funzionamento anomalo o non previsto dell'apparecchiatura.
- È necessario eseguire un ripristino manuale dopo l'installazione iniziale o il ciclo di alimentazione.

Deutsch

Vorsicht



- Halten Sie Kinder und Tiere während der Benutzung vom Tisch fern. Achten Sie darauf, dass die Tischplatte keine Wände berührt.
- Entfernen Sie Hindernisse, die höher als 20"/51 cm Zoll sind, von der Unterseite des Tisches.
- Betreiben Sie das Gerät nur in einer Arbeitsumgebung mit einer Temperatur von 32°F-104°F/0°C-40°C.
- Halten Sie das Produkt von ätzenden Gasen, Flüssigkeiten und staubigen Gegenständen fern.
- Halten Sie Hände, Füße und andere Körperteile während des Betriebs in einer sicheren Position. Der Antikollisionsschutz wird nach den Zurücksetzen nicht automatisch aktiviert.
- Das Unternehmen übernimmt keine Garantie oder Haftung für Schäden und Verletzungen, die durch einen abnormalen oder unbeabsichtigten Betrieb des Geräts verursacht werden.
- Nach der Ersteinrichtung oder dem Ersteinrichten der Stromversorgung muss eine manuelle Rückstellung vorgenommen werden.

Français

Attention

- Pendant l'utilisation, gardez les enfants et les animaux à l'écart du bureau. Veillez à ce que le bureau ne touche aucun mur.
- Éliminez les obstacles de plus de 20"/51 cm pouces de hauteur sous le bureau.
- N'utilisez le produit que dans un environnement de travail dont la température est comprise entre 32°F-104°F/0°C-40°C.
- Éloignez le produit de toute source de gaz corrosifs, de liquides et d'objets poussiéreux.
- Gardez les mains, les pieds et les autres parties du corps dans une position sûre lorsque vous utilisez l'appareil. L'anticollision n'est pas automatiquement activée après les réinitialisations.
- Aucune garantie ou responsabilité n'est assumée par la société pour les dommages et les blessures humaines causés par un fonctionnement anormal ou non intentionnel de l'équipement.
- Une réinitialisation manuelle est indispensable après l'installation initiale ou un cycle d'alimentation.

日本語

注意

- 本製品を使用している時、子供や動物から遠ざけてください。デスクトップが壁に触れていないことを確認してください。
- 机の底から20インチより高い障害物を取り除いてください。
- 32°F-104°F/0°C-40°Cの作動環境温度のみで動作する。
- 本製品を腐食性ガス、液体、ほこりの多い物体から遠ざけてください。
- 操作中に手、足、その他の体の部分を安全な位置に保ってください。アンチ衝突は、すべてのリセット中に自動的に有効にされていません。
- このデスクを使用する前に、以下の取扱説明書をよくお読みください。
- 機器の異常または非意図的な操作によって引き起こされた損傷と人身傷害に対していかなる保証または責任も負いません。
- 初回装着または機器通電後、手動リセットが必要です。

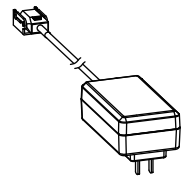
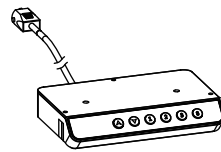
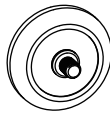
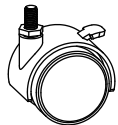
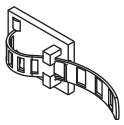
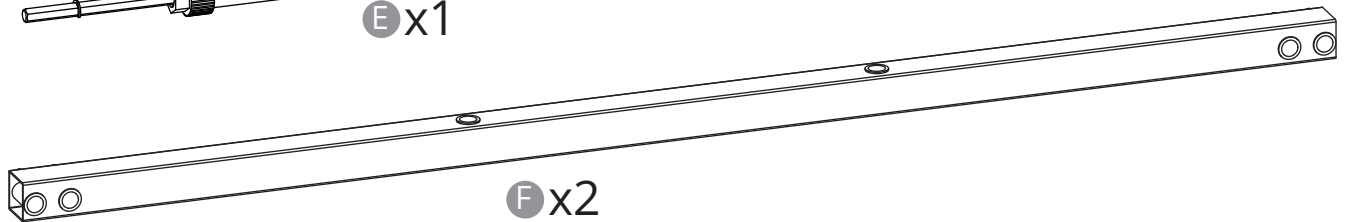
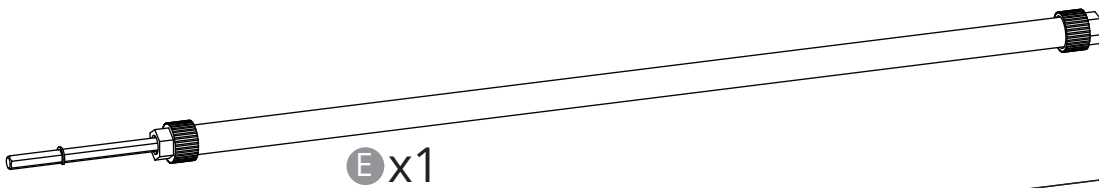
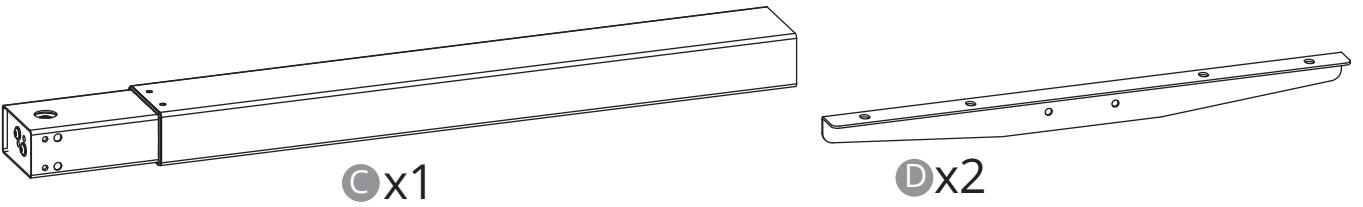
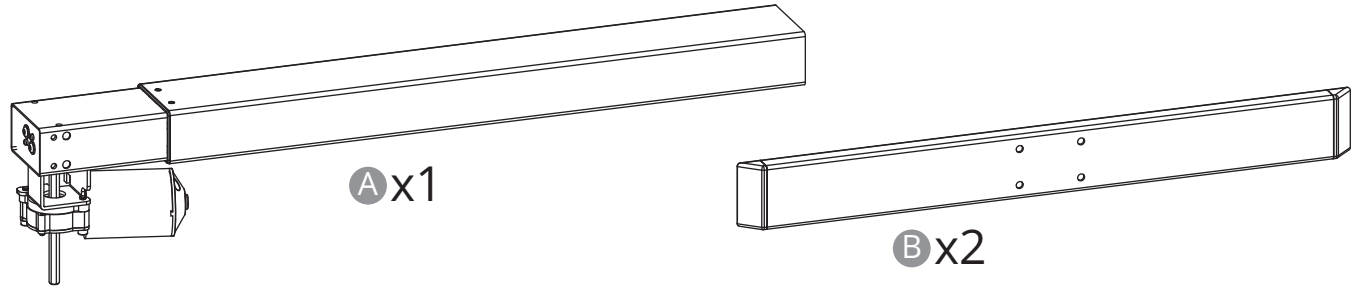
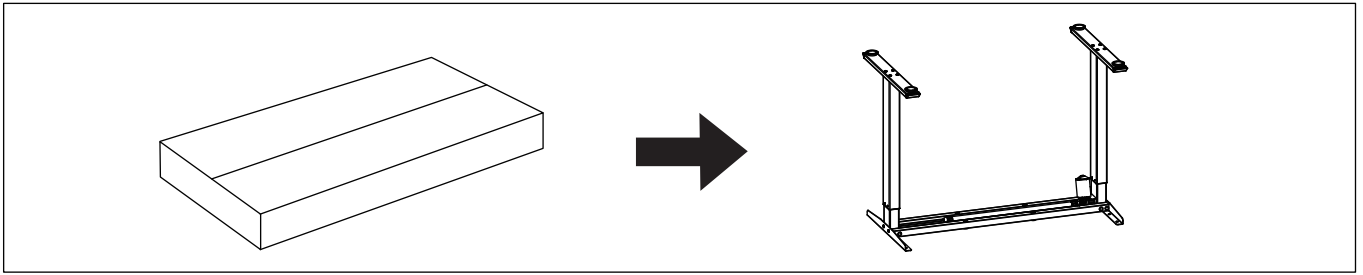

G x4

H1 x4

H2 x4

I x1

J x1

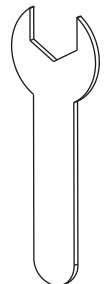
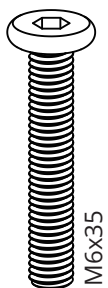
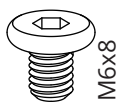

01 x12

02 x8

03 x3

04 x1

05 x1

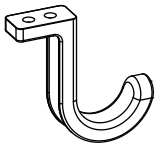
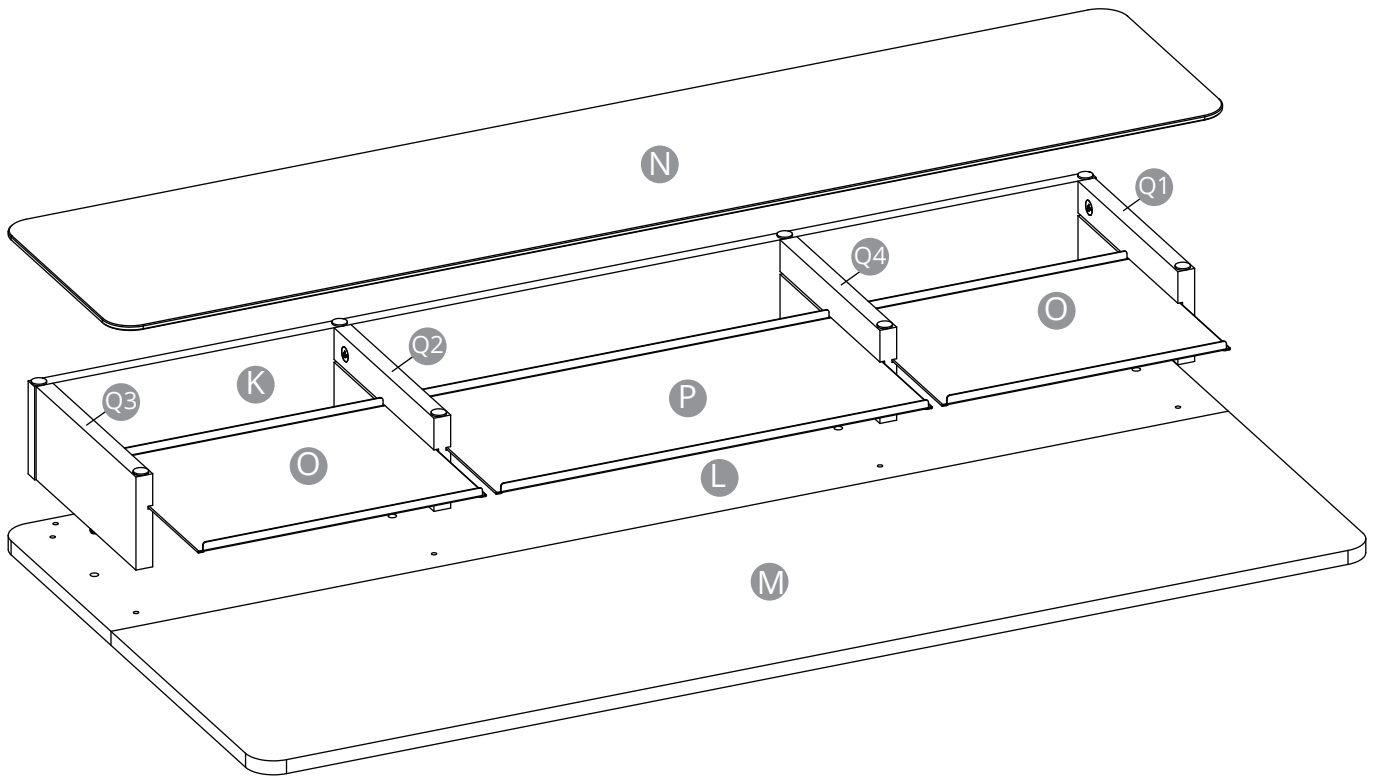

R x2



S x2

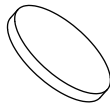

T x8

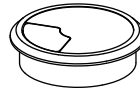

U x1

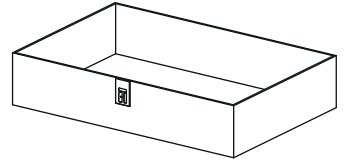

V x2

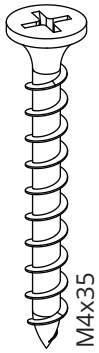

① x11



② x8



③ x16

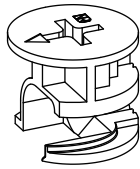

④ x4



⑤ x4



⑥ x8

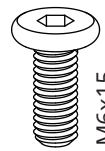

⑦ x4



⑧ x1

1

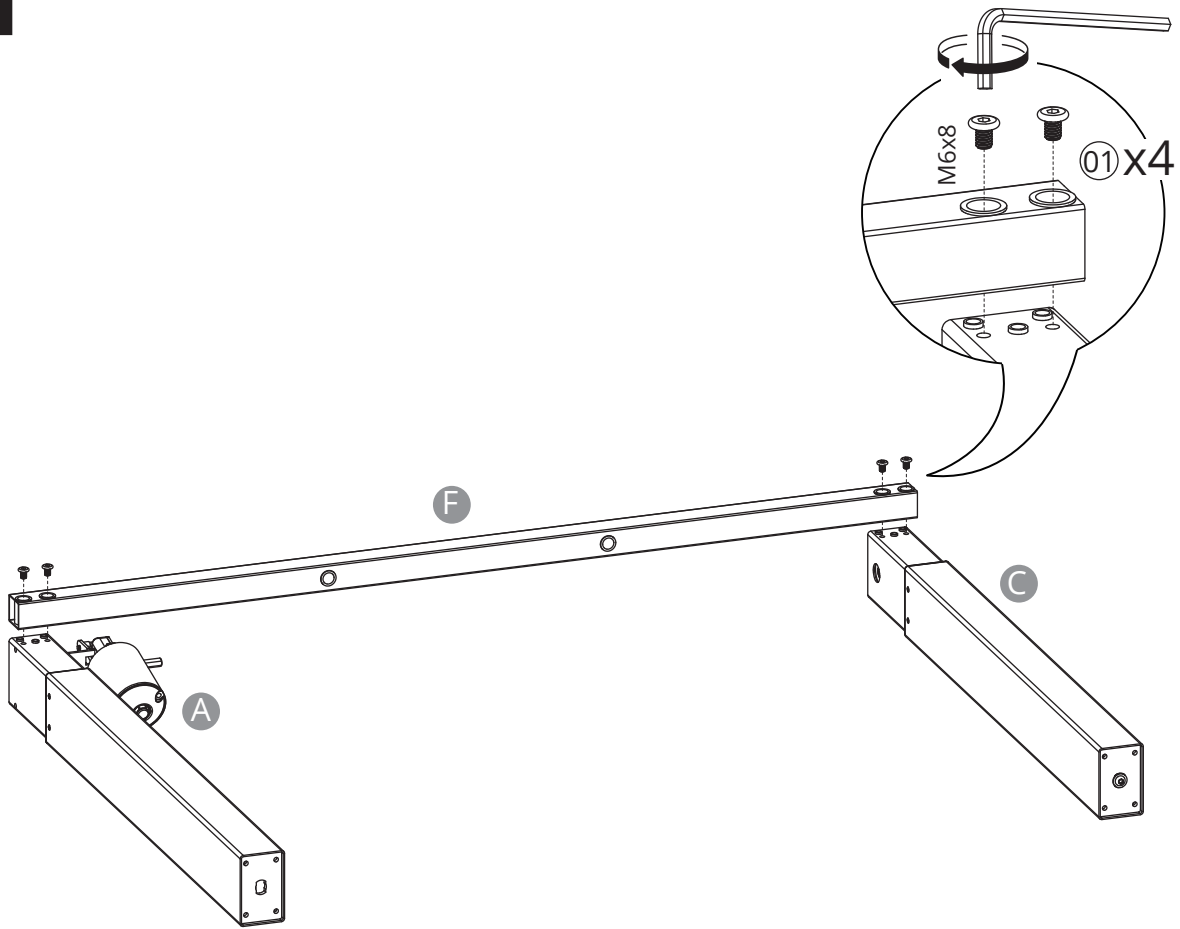

2

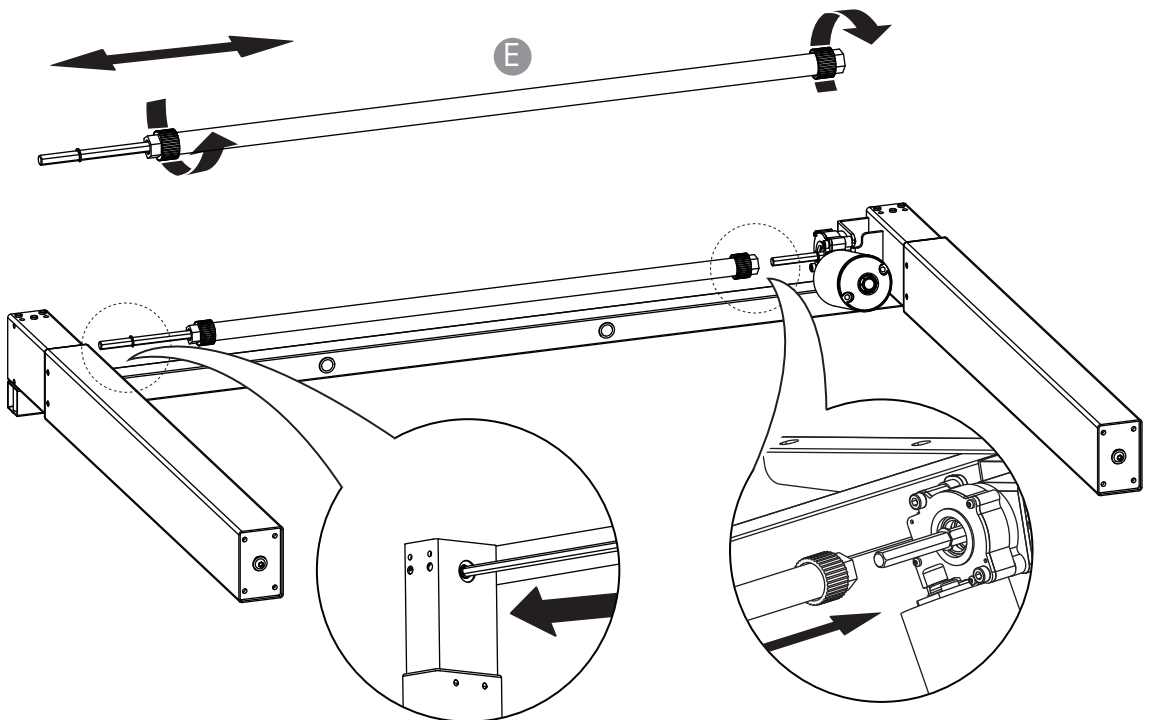

3

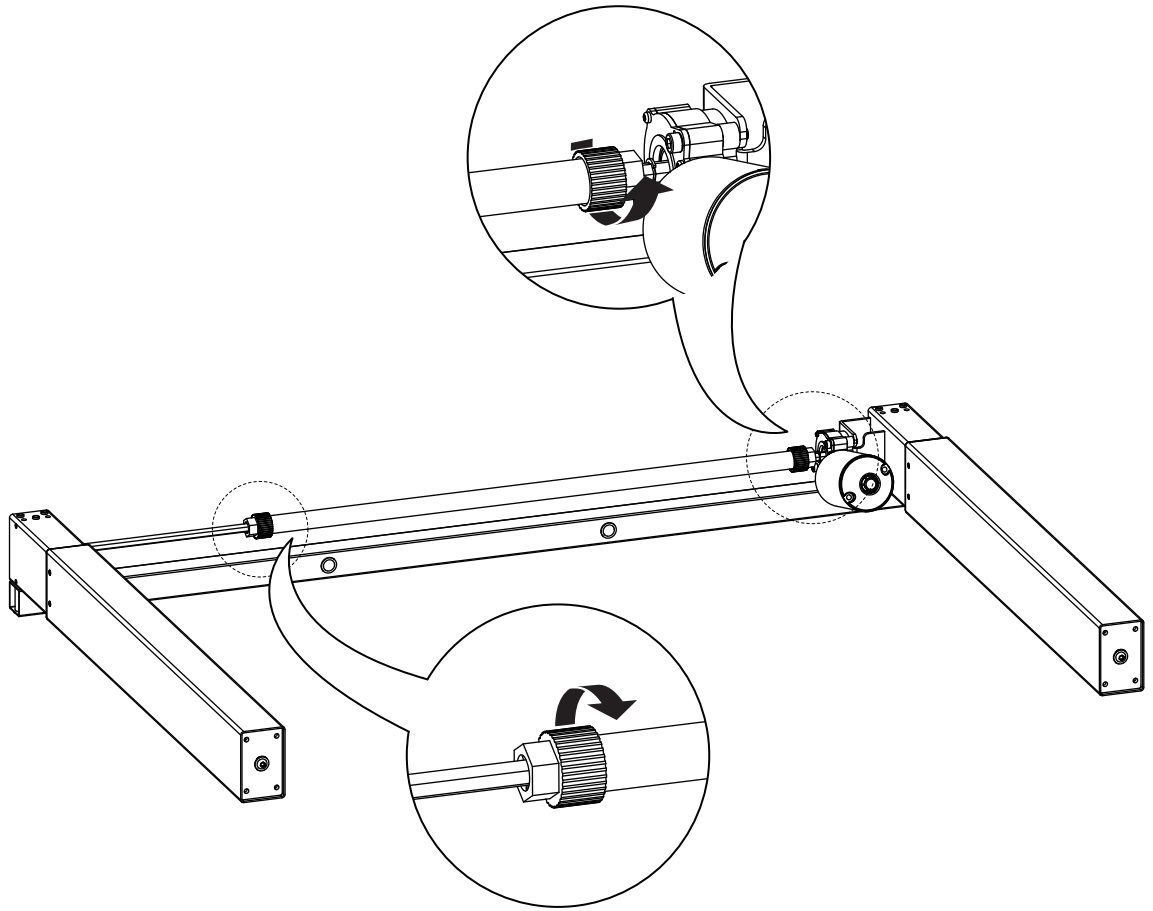

4

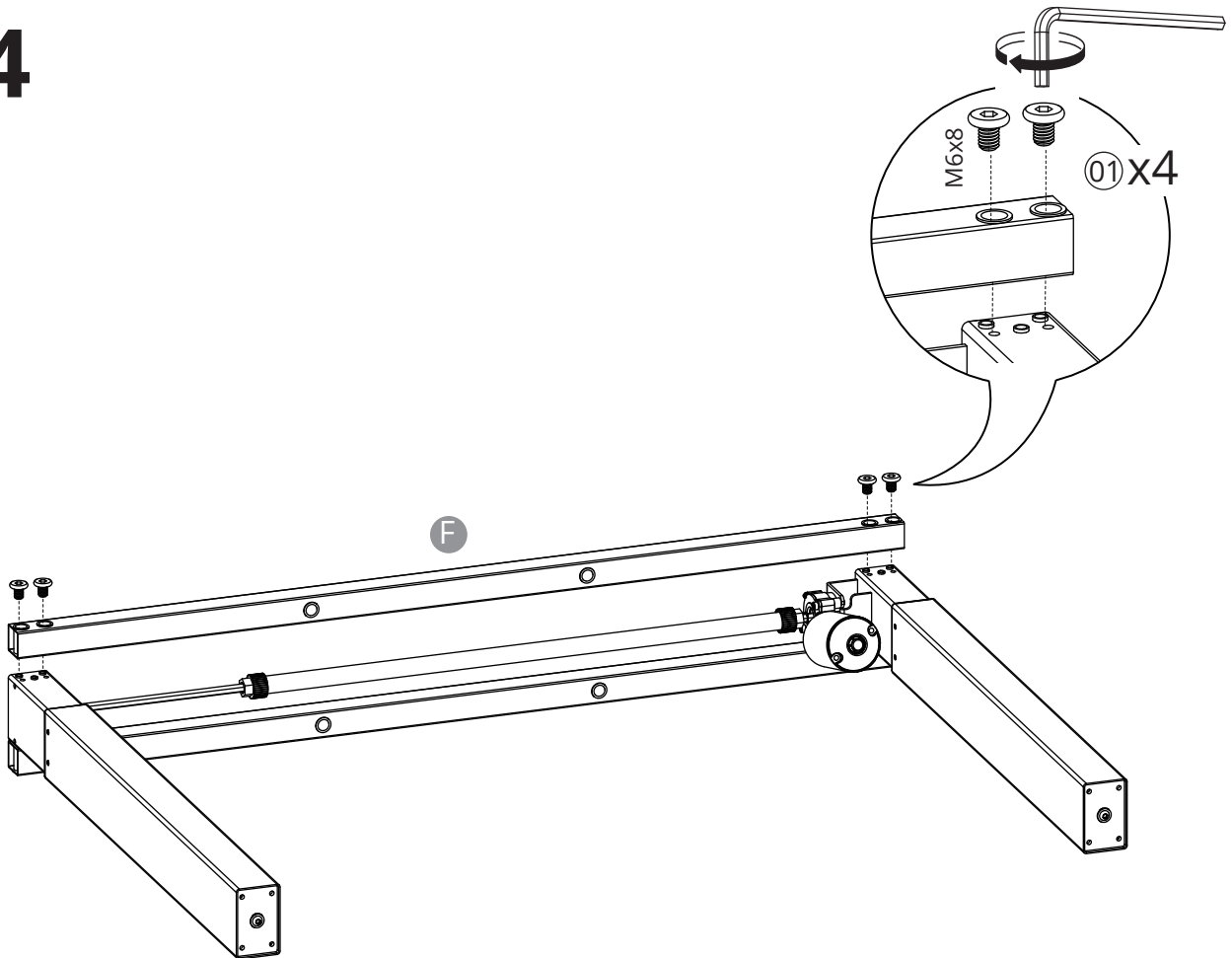

5

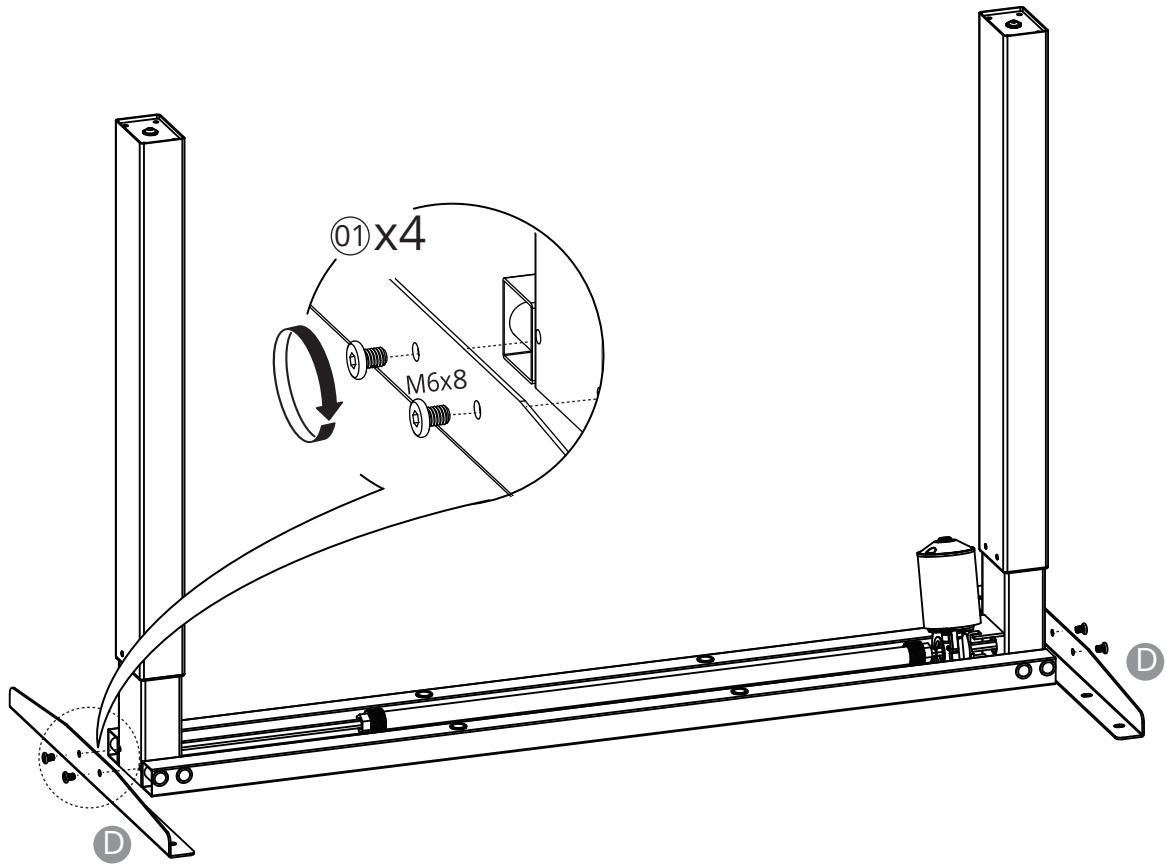

6

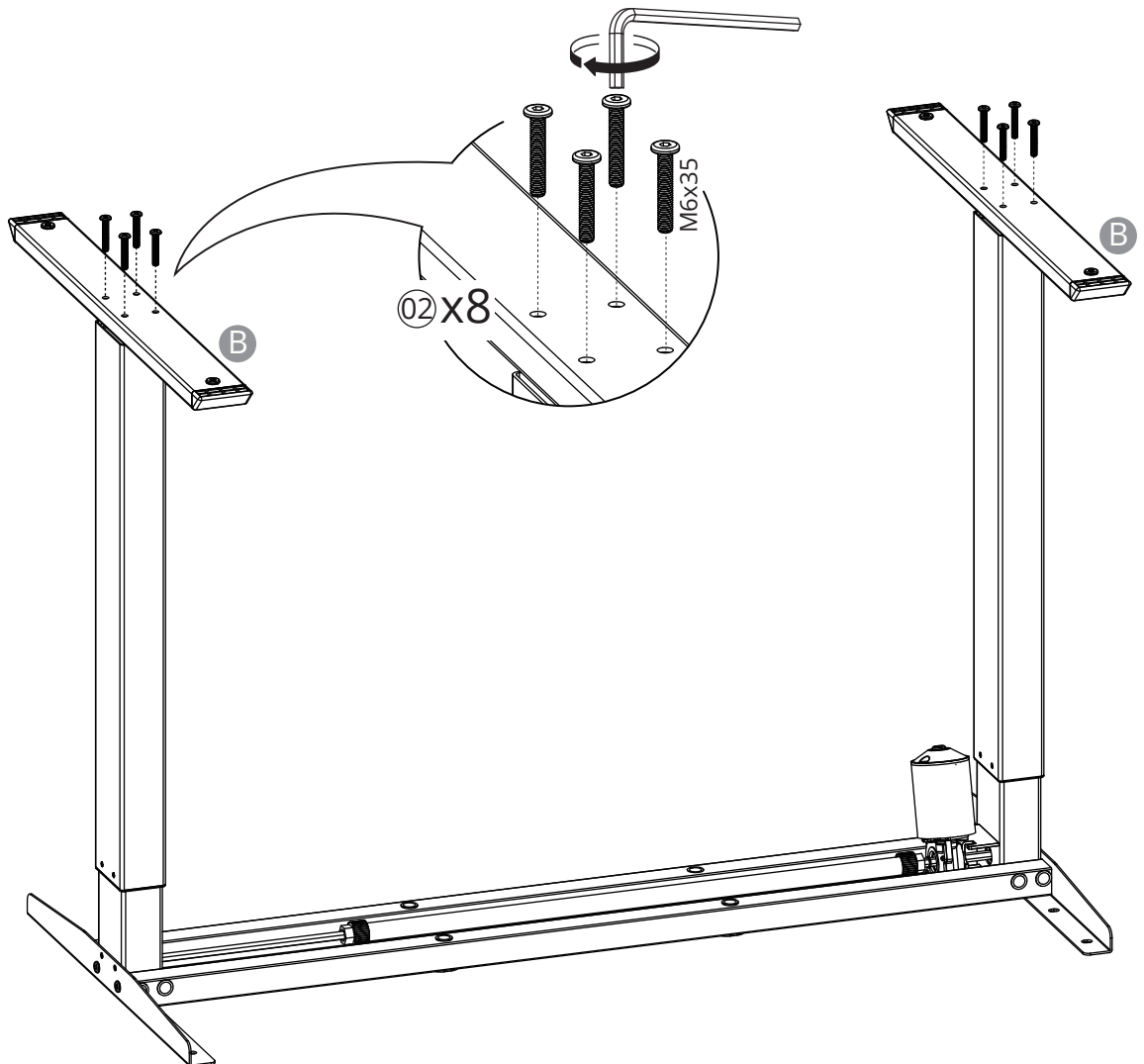

7

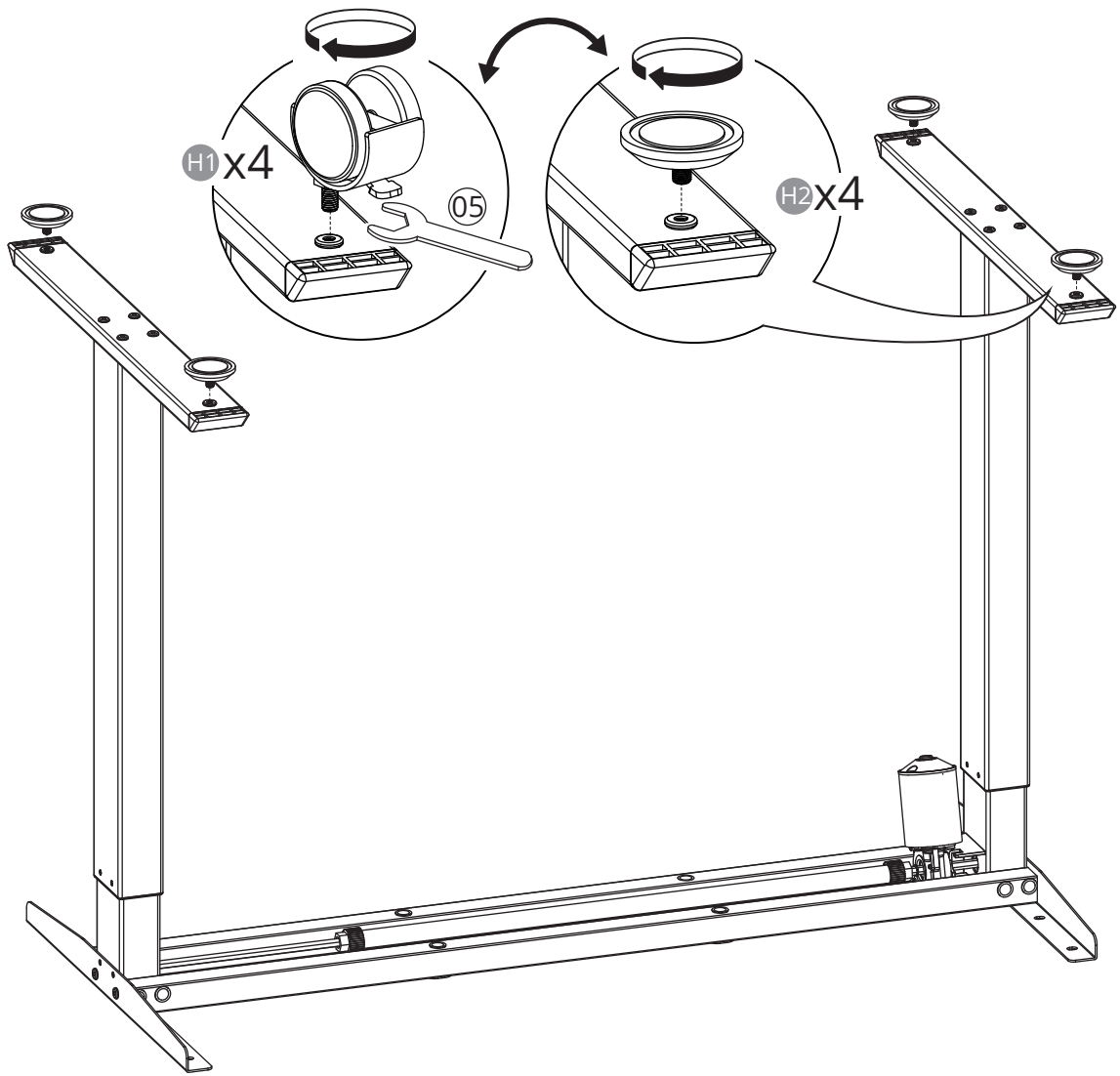

8

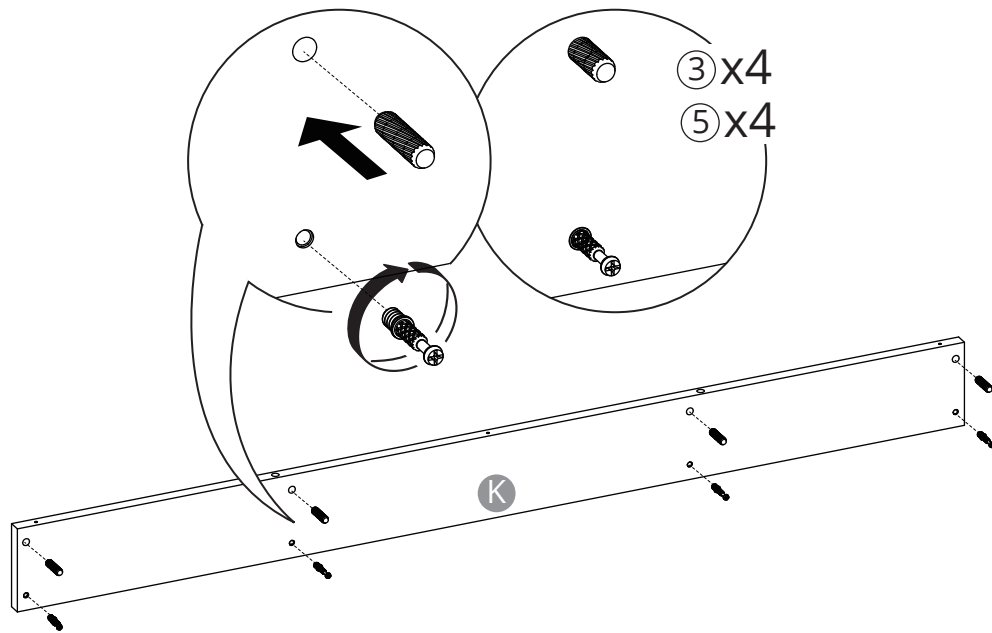

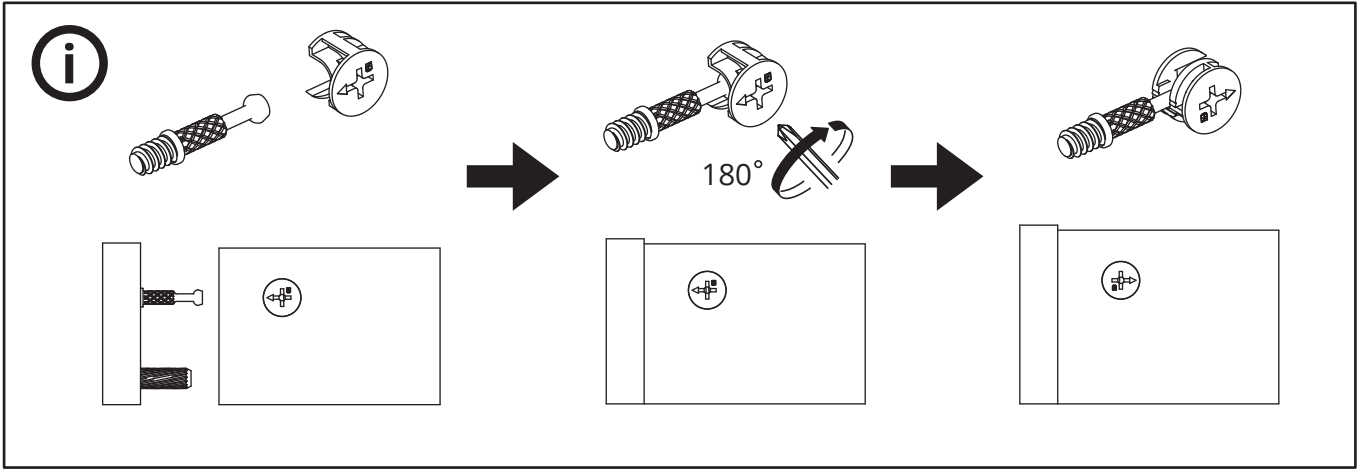

9

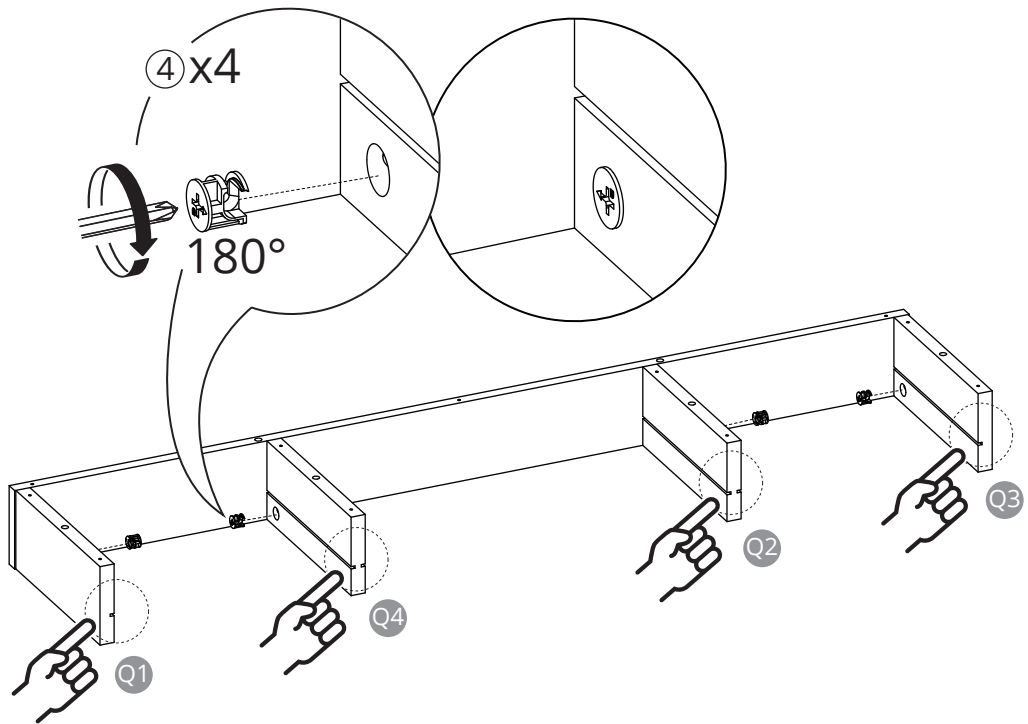

10

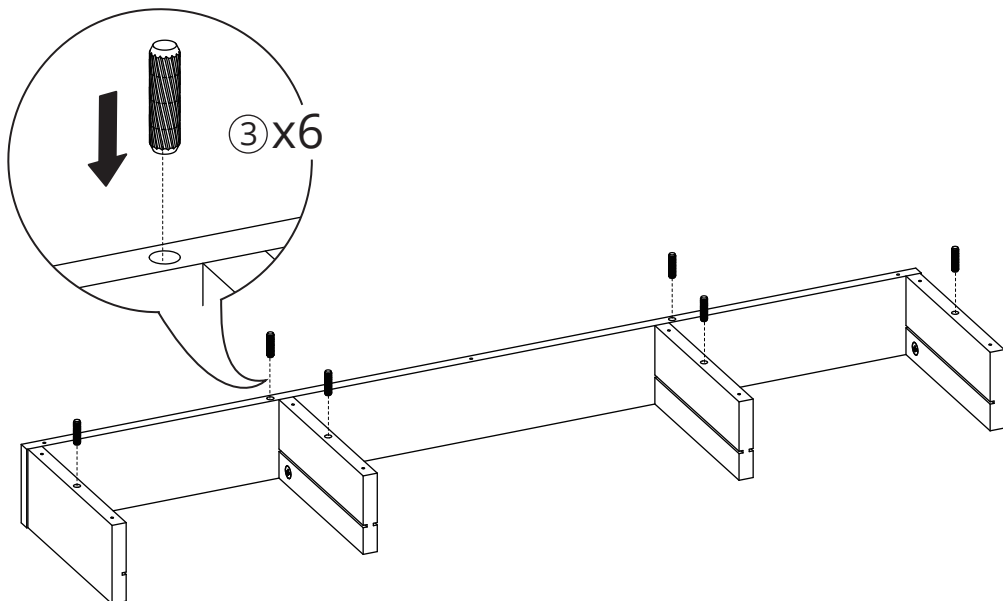

11

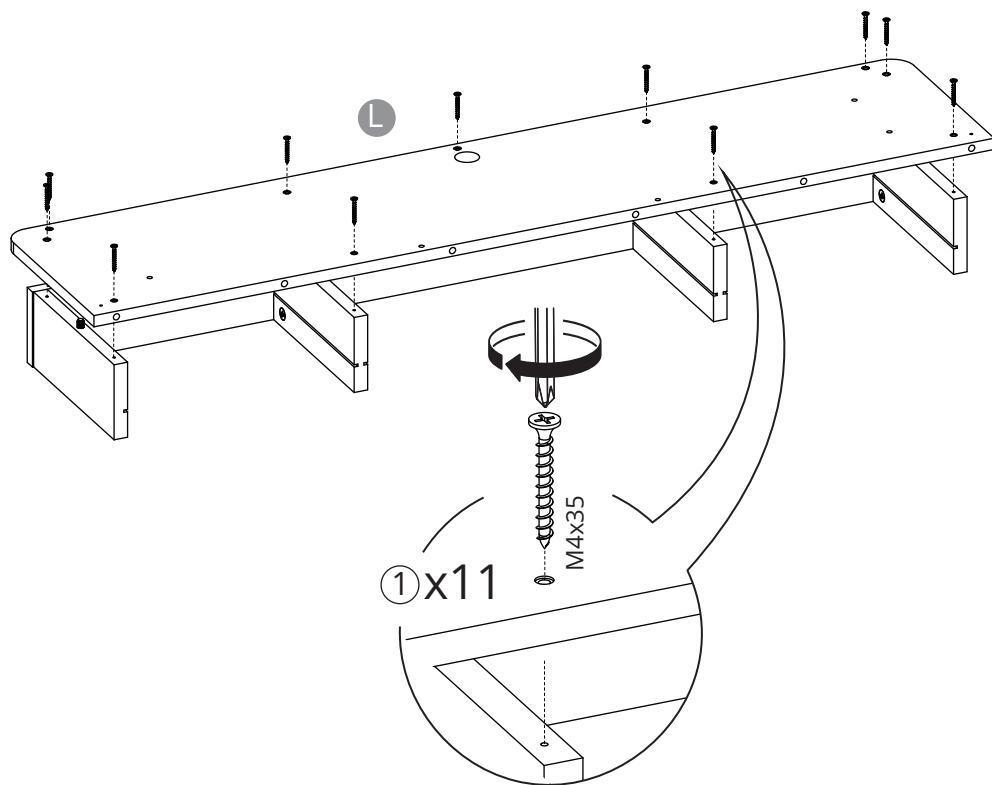

12

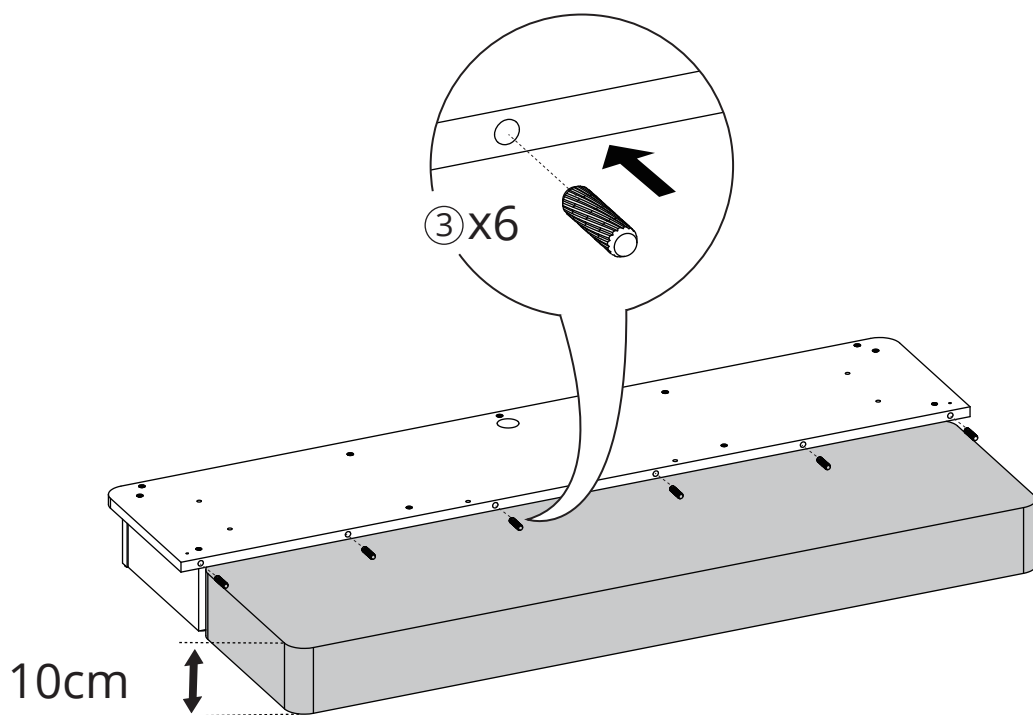

13

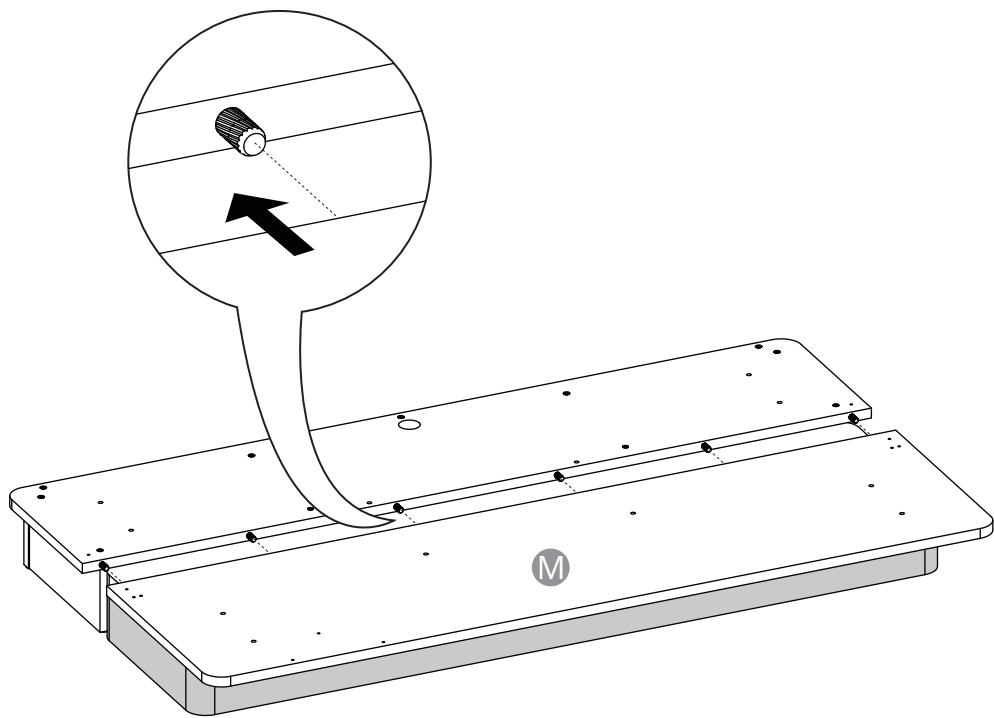

14

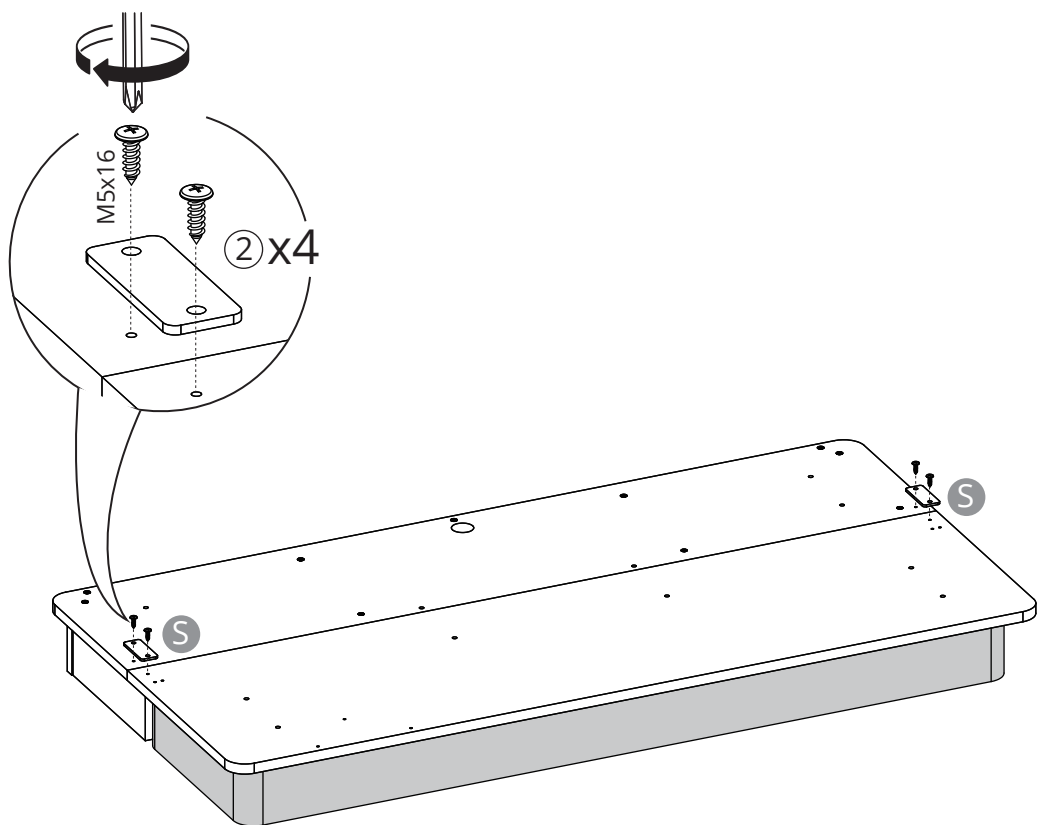

15

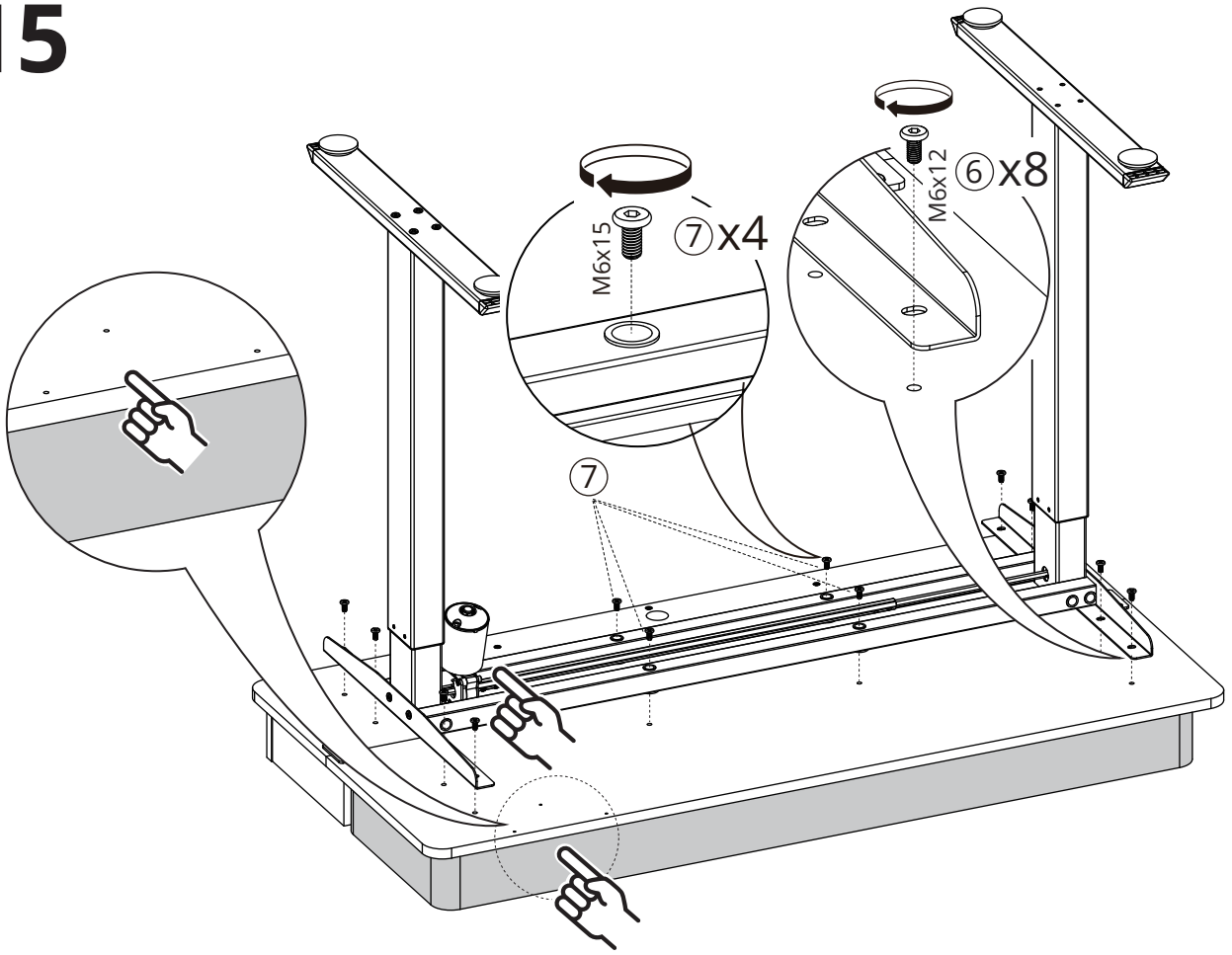

16

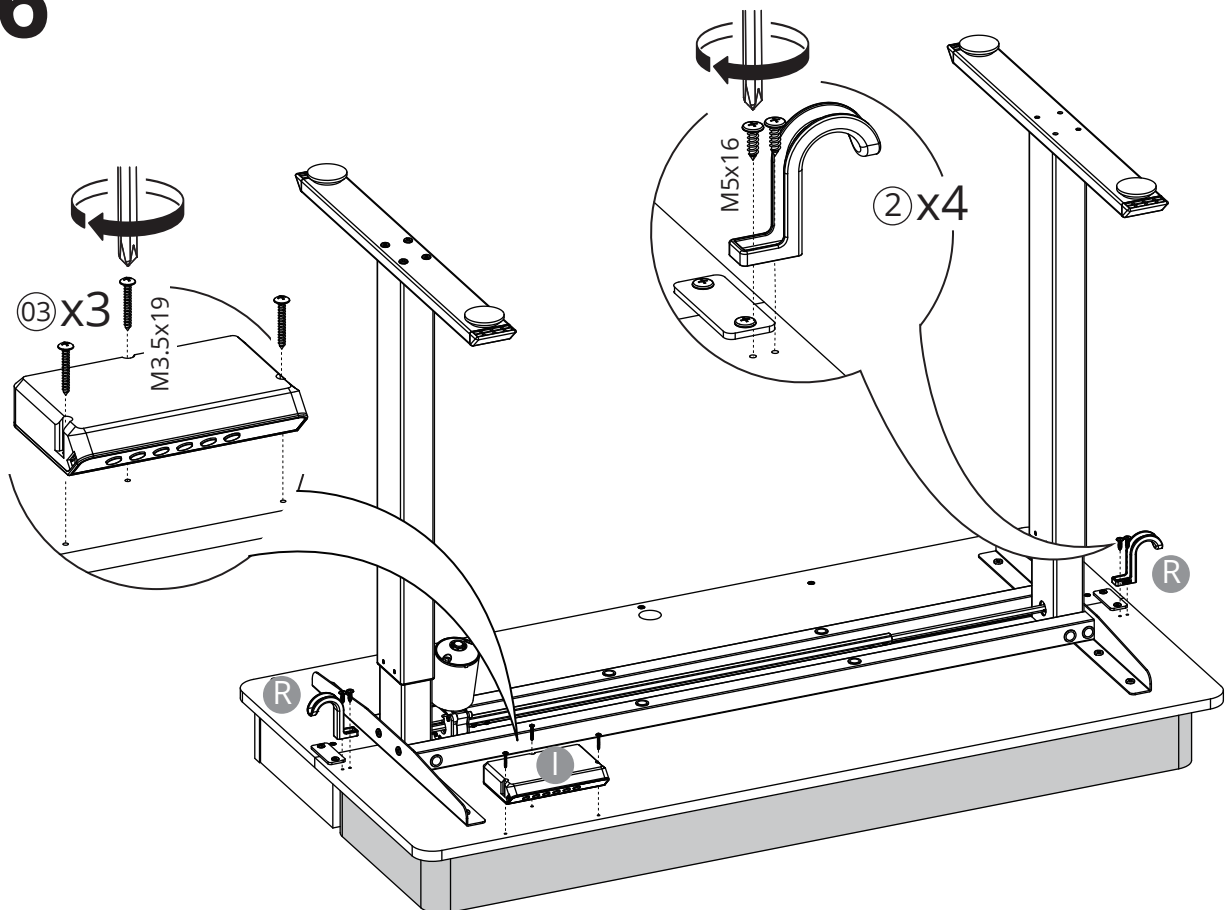

17

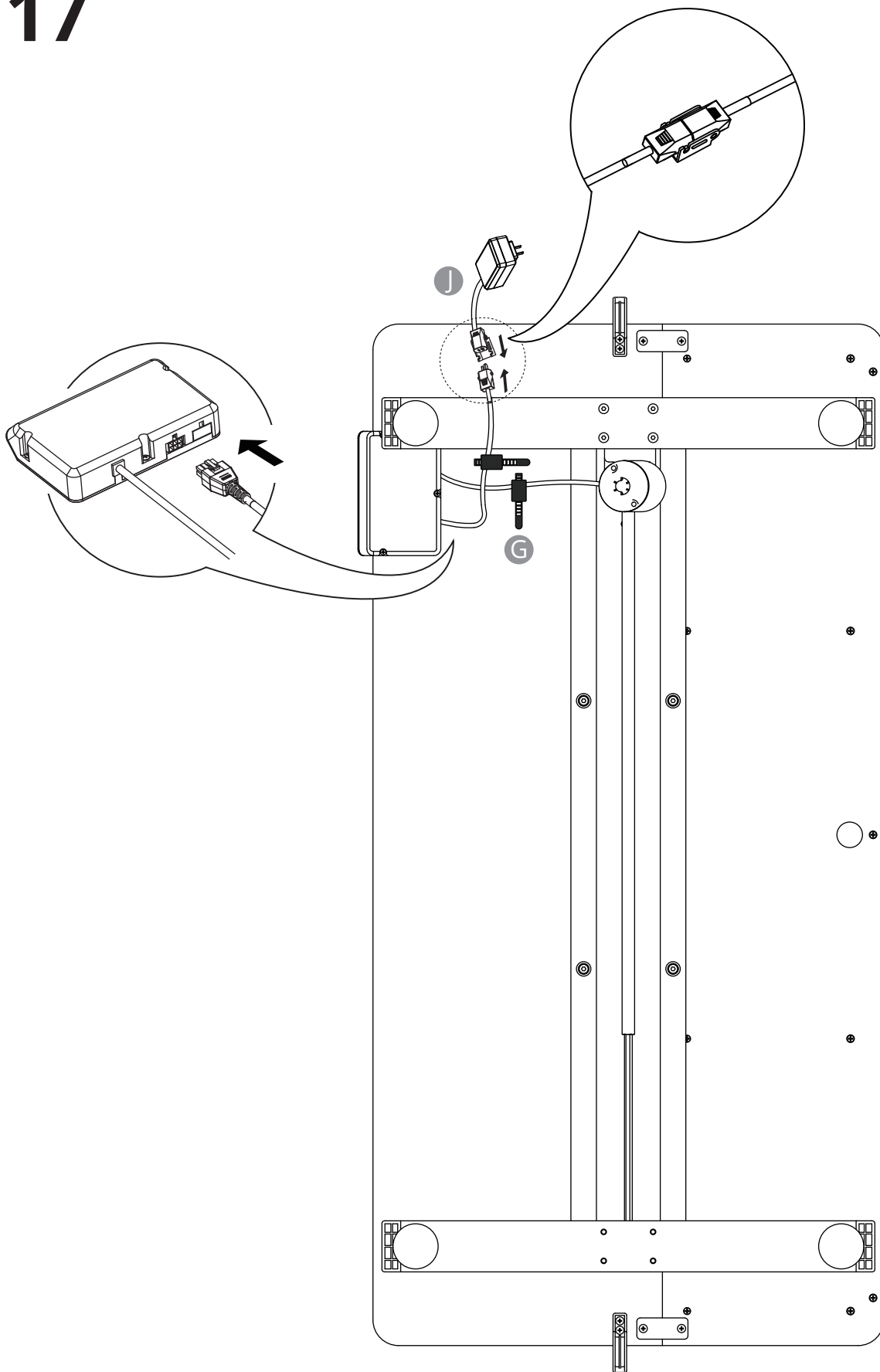

18

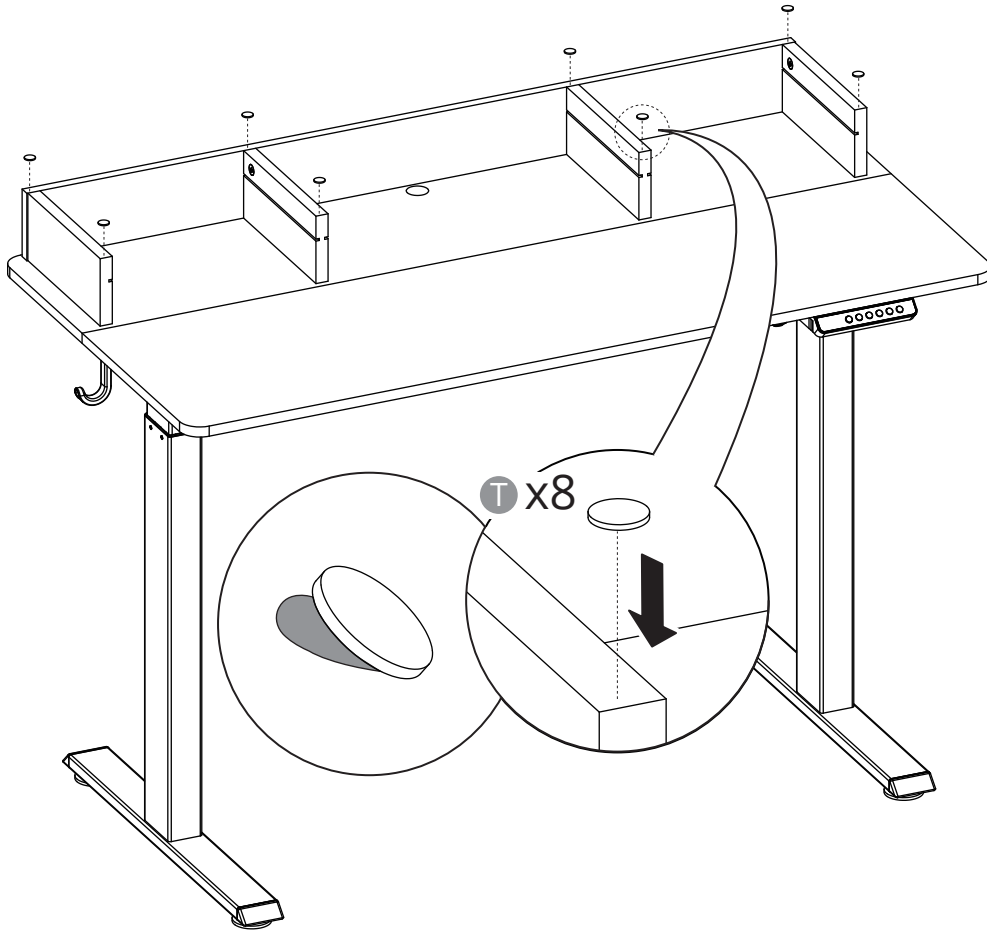

19

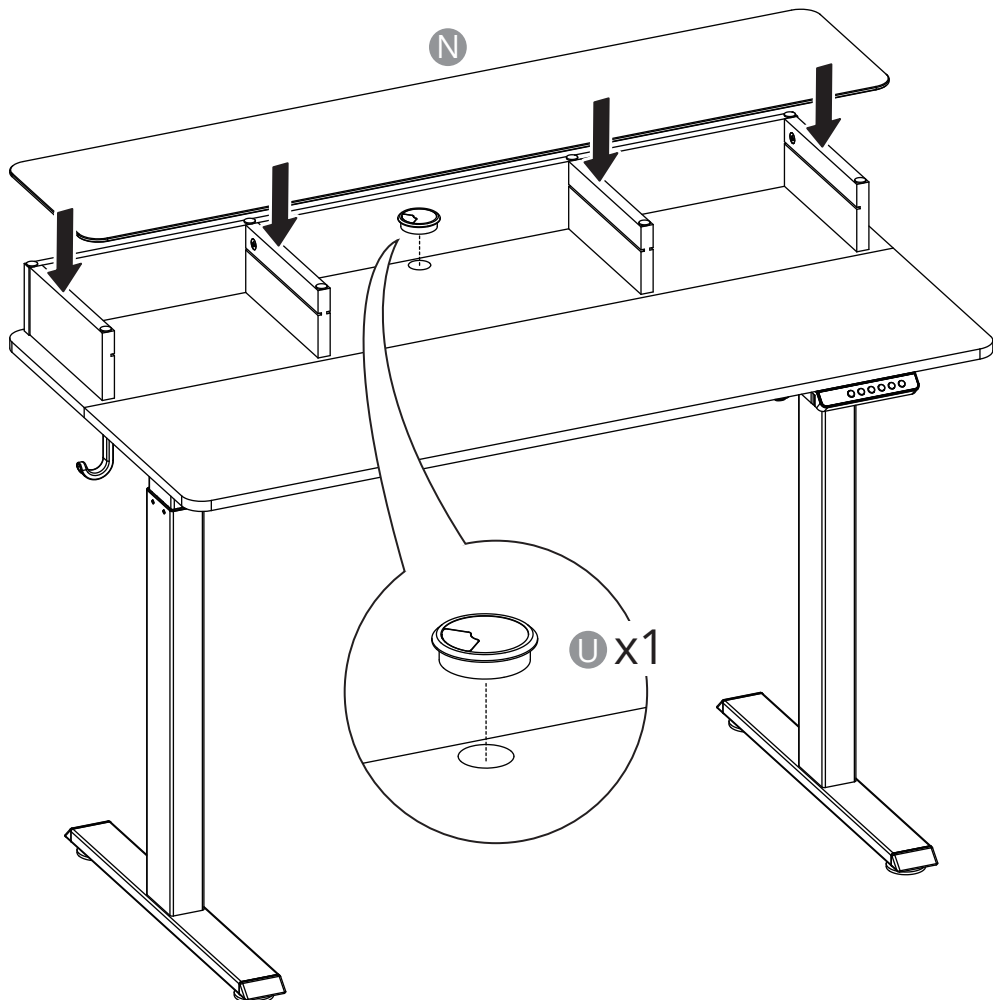

20

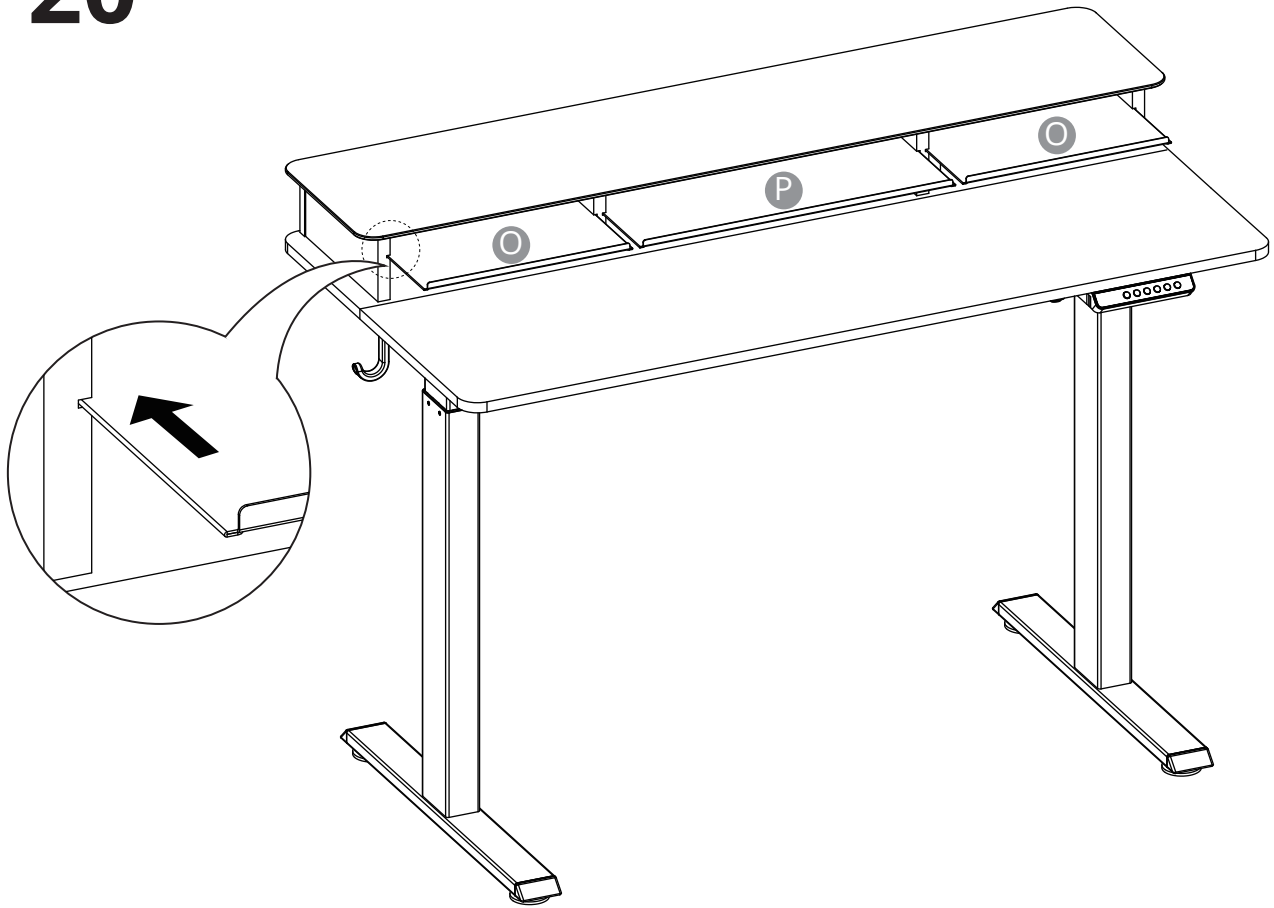

21

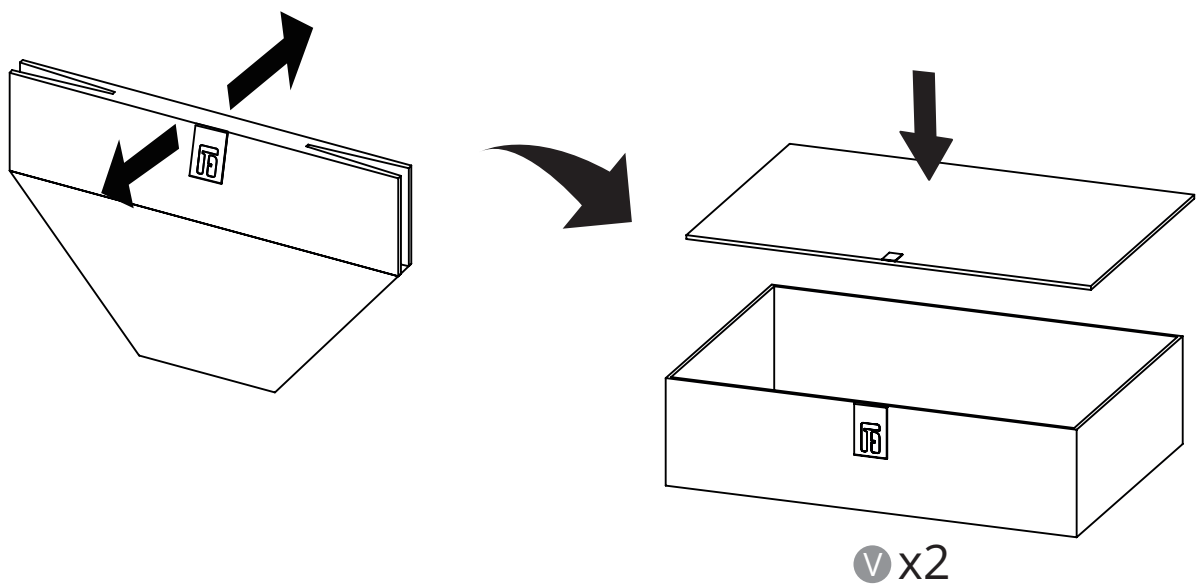

22

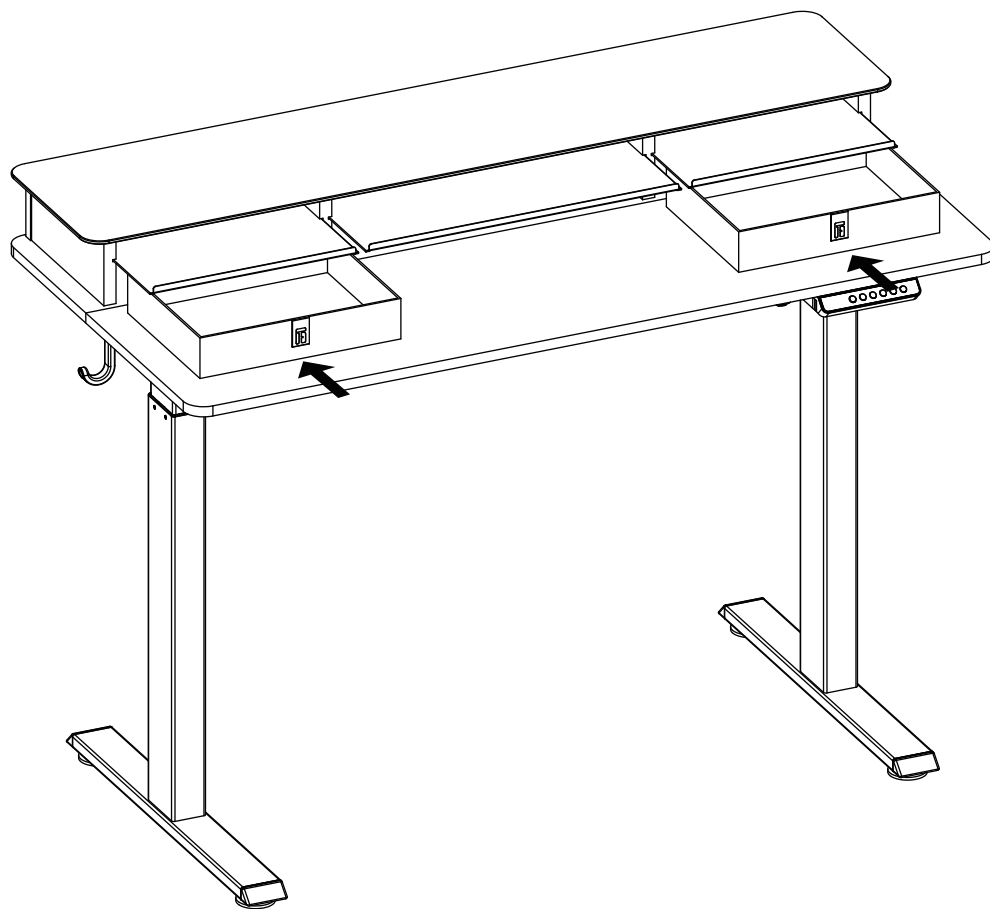

23

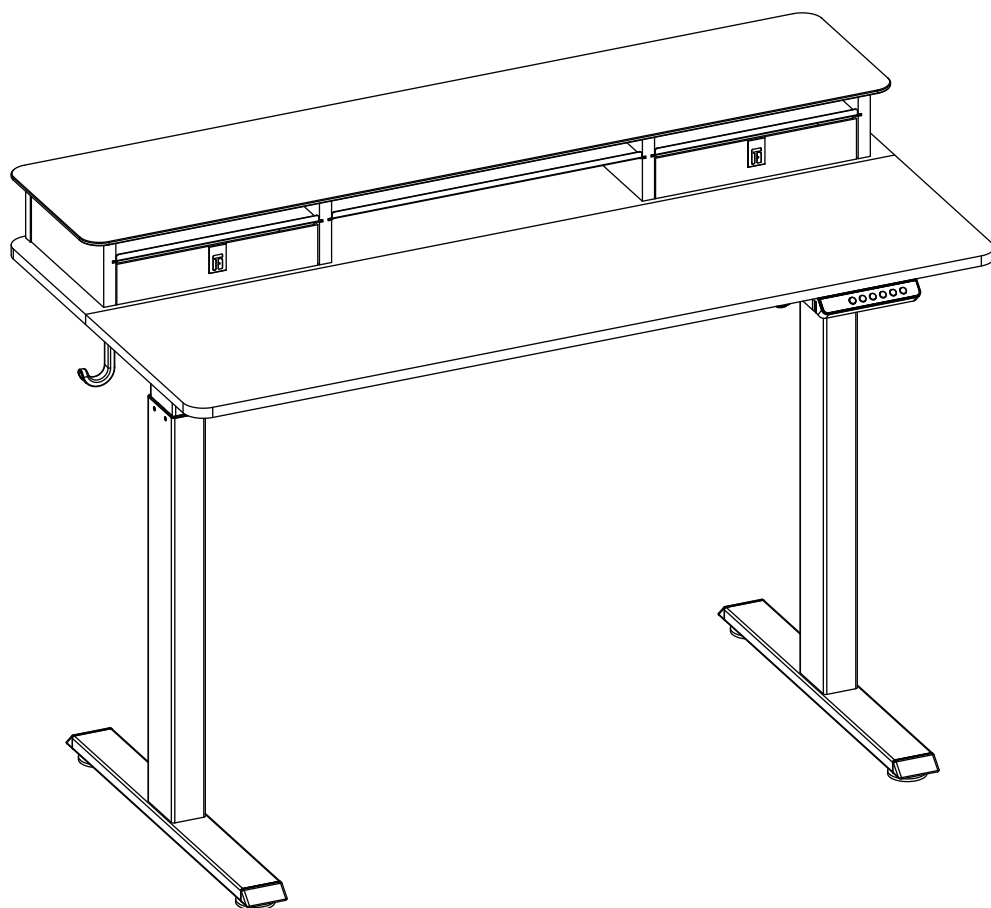





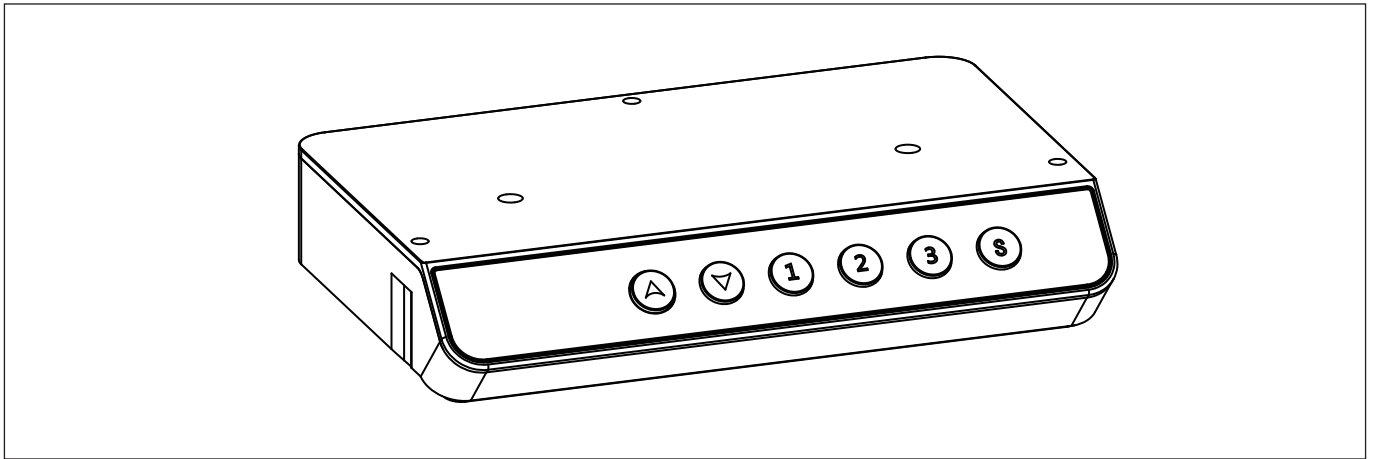



















English

Controller Instruction



Description of functions

Key name	Description	Press duration	Operation process	Remarks
⬆	Raise the desktop	Long press	Press and hold the ⬆ key to raise the desktop and enable the LED screen to display the real-time height value, and release it to stop the height adjustment.	
⬇	Lower the desktop	Long press	Press and hold the ⬇ key to lower the desktop and enable the LED screen to display the real-time height value, and release it to stop the height adjustment.	
① ② ③ S	Set the memory heights	Press the S key once	Press the S key once and the height value starts flashing. At this time, press the ①, ② or ③ key to save the current height to the corresponding position.	1. If you press no numeral key within 15s after the height value starts flashing or press the S key while the height value is flashing, you can exit the memory setting mode.
① ② ③	Move to the memory height / To use memory heights	Press the numeral key once	Press the numeral key to enable the height adjustable desk to automatically move to the corresponding preset height.	1. The anti-collision detection is activated when moving / adjusting the desk (height). Desk movement will stop when there is obstacle in its path. 2. The movement will stop if any key is pressed in the process of movement.

	Reset	<p>Long press the  and  buttons simultaneously for 3s</p>	<p>Reset in the "E-1" or "E-2" alarm state or in any position: Long press the  and  buttons simultaneously for 3s. The LED screen will display "rst" and "E-1" alternately. With the buttons not released during the whole process, the desktop will continue moving down to the lowest mechanical zero and move back 5mm, and the LED screen will display the minimum height of 70.0 or 27.5, which indicates that the reset is complete.</p>	<ol style="list-style-type: none"> 1.All protective functions are disabled during the reset process. 2.The reset can also be performed if the lower height limit is set.
	Height range setting	Long press for 6s	<p>Press and hold the  key. When the LED displays "HLP", release the  key. At the moment, the LED flashes and displays "HLP" and the current height value. At the moment, the current height value can be adjusted by the  or  keys:</p> <ol style="list-style-type: none"> 1. Press the number key  , and the LED will flash and display "H-P". At the moment, pressing the  or  keys will not respond. You can only press the  key to save the current value. 2. Press the number key  , and the LED will flash and display "LH-P". At the moment, pressing the  or  keys will not respond. You can only press the  key to save the current value. 3. Press the number key  to directly delete the set maximum and minimum heights. 	<ol style="list-style-type: none"> 1. If you do not press the  key within 15s after "HLP" and the current height value start flashing alternately on the LED screen, you will quit this setting mode. 2. When "HLP" and the current height value alternately flash on the LED screen, the current height value must be adjusted by pressing the  or  key. 3. When "HLP" and the current height value alternately flash on the LED screen, press the numeral key  to delete the saved maximum and minimum heights.
	Restore factory settings	Long press for 9s	<p>Long press the  key, release it when the LED screen displays "FAC", and press it again to restore the factory settings.</p>	<ol style="list-style-type: none"> 1. If you do not press the  key within 15s after "FAC" starts flashing on the LED screen, you will exit / quit the setting mode. 2. When the factory settings are restored, existing memory position, height range, sensitivity and unit will be erased.

				3. After the factory settings are restored, they will be displayed (including 3 memory positions, sensitivity, and unit)
Ⓢ	Unit conversion	Long press for 3s	Long press the Ⓢ key, release it when the LED screen displays "SET", and press the numeral key ① to start unit conversion setting. At this time, "unt" and the current height value alternately flash on the LED screen. Adjust the unit by the ▲ or ▼ key, and press the Ⓢ key to save the current setting.	1. When "unt" and the current height value alternately flash on the LED screen, if you do not press the Ⓢ key for confirmation after adjusting the unit by the ▲ or ▼ key, the system will automatically save the current unit setting after 15s.
Ⓢ	Adjust the sensitivity for stopping in case of resistance	Long press for 3s	Long press the Ⓢ key, release it when the LED screen displays "SET", and press the numeral key ② to start sensitivity setting. At this time, "cpt" and the current sensitivity value alternately flash on the LED screen. Adjust the sensitivity value by the ▲ or ▼ key, and press the Ⓢ key to save the current setting.	1. The sensitivity can be 0/1/2/3/4. The larger the number, the higher the sensitivity; 2. When "cpt" and the current sensitivity value alternately flash on the LED screen, if you do not press the Ⓢ key for confirmation after adjusting the sensitivity value by the ▲ or ▼ key, the system will automatically save the current sensitivity setting after 15s.
Ⓢ	Lock keys	Long press for 3s	Long press the Ⓢ key, release it when the LED screen displays "SET", and press the numeral key ③ to lock the screen. At this time, "OFF" is displayed and flashes on the LED screen.	1. When the screen is locked, long press the Ⓢ key for 3s until the LED screen displays the height value, and then release it to complete the unlocking.

Description of faults

Fault name	Fault code	Description	Troubleshooting
Communication fault		"Err" is displayed when the sequence of communication wires between the hand controller and the control box is wrong	1. Check whether the connection is tight 2. Replace the hand controller and the control box

Power-on reset	E-1	"rSt" and "E-1" are displayed and alternately flash on the LED screen when the current position is not saved in the system	Reset the system until the LED screen displays the minimum. Then the alarm will be cleared
Locked-rotor protection	E-2	The LED cyclically displays "rSt+E-2" when the rotor of the motor is locked	The problem can be solved after a reset.
Reverse movement in case of resistance	E-3	In case of sudden resistance in the operation process, "E-3" is displayed and flashes on the LED screen, the desk stops movement and moves by 30mm in the opposite direction, and then the LED screen displays the real-time height	Make sure that the desk does not vibrate greatly, hit any obstacle or tilt in the operation process
Column imbalance	E-4	The LED cyclically displays "rSt+E-4" when the imbalance of double columns exceeds 20MM	"E-4" is displayed only for double columns
Motor fault	E-5, E-6	In case of any disconnected / loosened wire, motor 1 is faulty and "rSt" and "E-5" are displayed and alternately flash on the LED screen; or motor 2 is faulty and "rSt" and "E-6" are displayed and alternately flash on the LED screen.	<ol style="list-style-type: none"> "rSt" and "E-6" are displayed and alternately flash only for double columns / only on dual motor desks Check all the wire connections between the motors and the controller, make sure they are secure, and then reset the system until the LED screen displays the minimum to clear the alarm.
Overload protection	ovr	"ovr" is displayed and flashes on the LED screen when the load exceeds the set value (normally the load should be controlled below 80KG).	This alarm can be cleared by removing the weight from the desktop and powering off and on the controller.
Overvoltage protection	Blank screen	The LED screen goes blank when the input voltage of the controller exceeds 32V.	<ol style="list-style-type: none"> The controller is powered off and the LED screen goes blank when the voltage exceeds 32V. The system automatically recovers and the LED displays the real-time height when the voltage drops to 32V.
Motor overheating protection	hot	The LED screen displays "hot" 2min after a continuous motor operation. Normal operation can resume after a 15min wait.	<ol style="list-style-type: none"> Continuous operation implies a long period of desk motor operation with intervals less than 3s. This alarm can also be cleared by powering on the control system again.