

# ASSEMBLY INSTRUCTION

## 23V06-21WHL

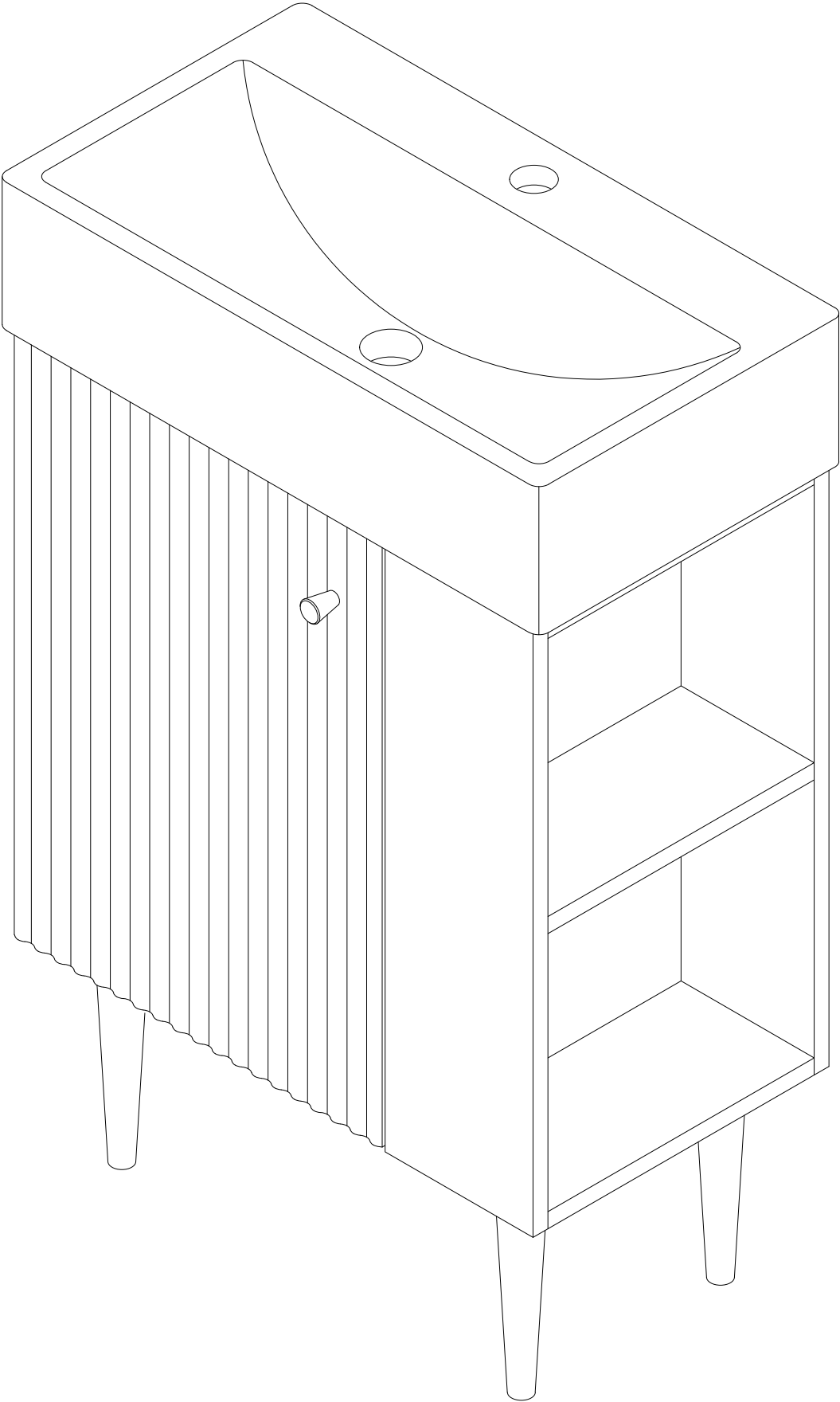

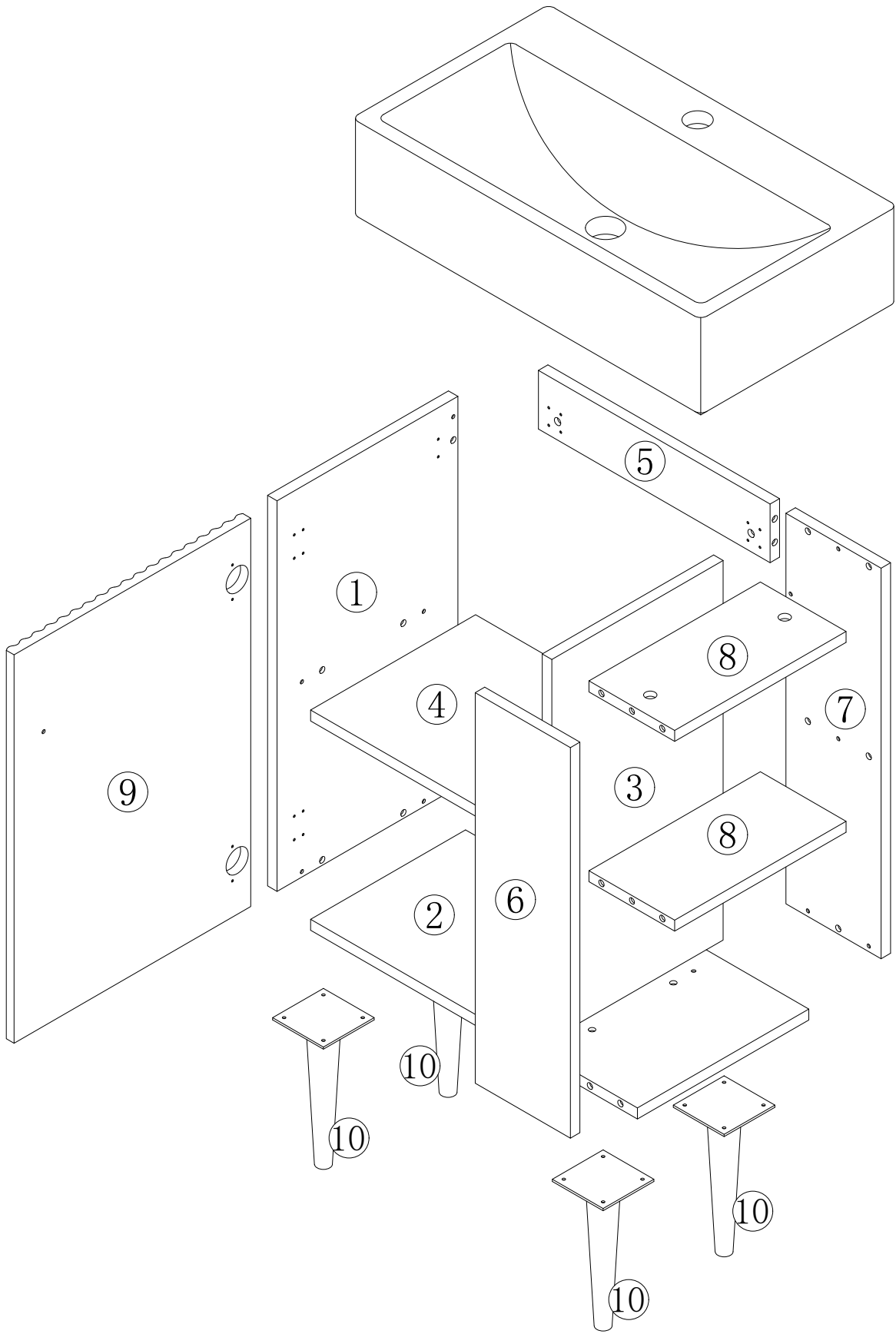

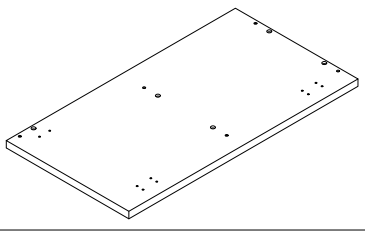
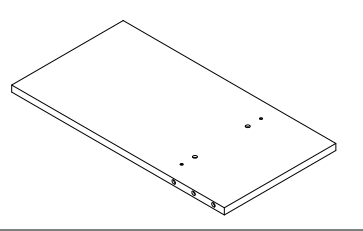
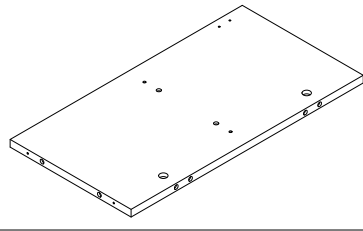
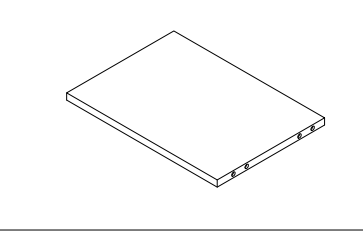
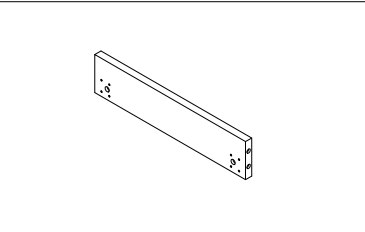
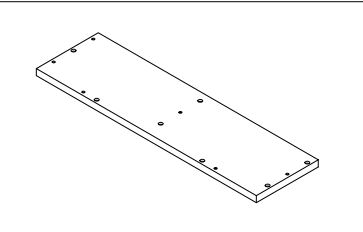
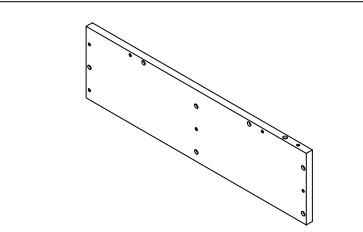
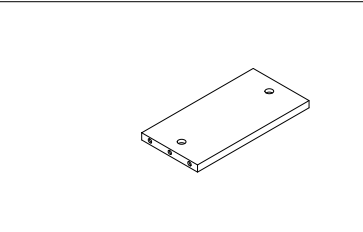
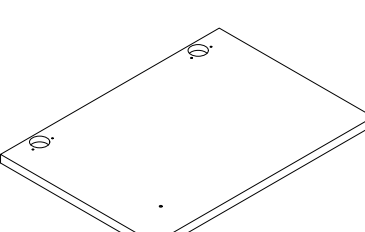
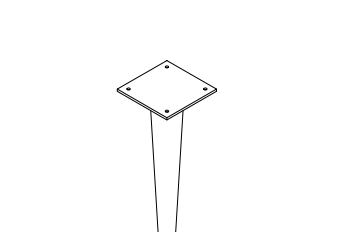



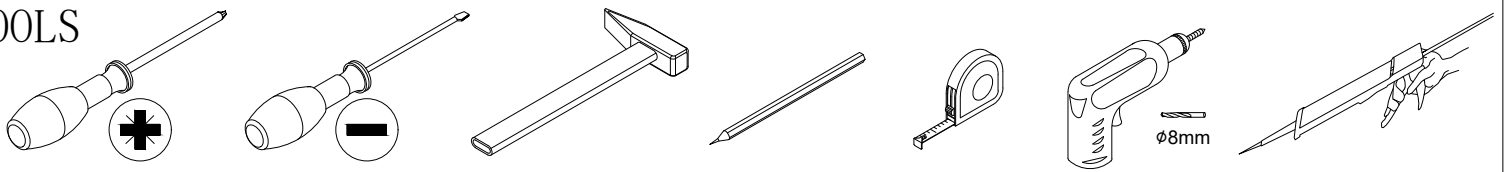

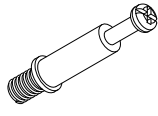

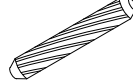

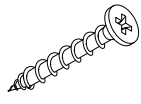
			
① x1	② x1	③ x1	④ x1
			
⑤ x1	⑥ x1	⑦ x1	⑧ x2
			
⑨ x1	⑩ x4		

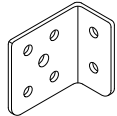
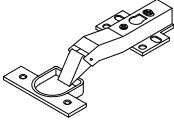
TOOLS

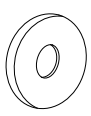
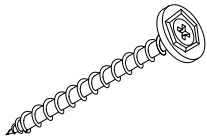

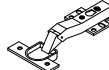

A * 16	B * 16	C * 24	D * 12	E * 28
				
M6 X 35mm	Ø15 x 12mm	Ø8 x 30mm	M4 x 14mm	M4 x 14mm
F * 6	G * 1	H * 1	I * 2	J * 2
				
M5 x 40mm	M4 x 20mm			Ø35
K * 2	L * 2	M * 2		
				
Ø8 x 40mm	Ø20	M6 x 60mm		

# Step 1

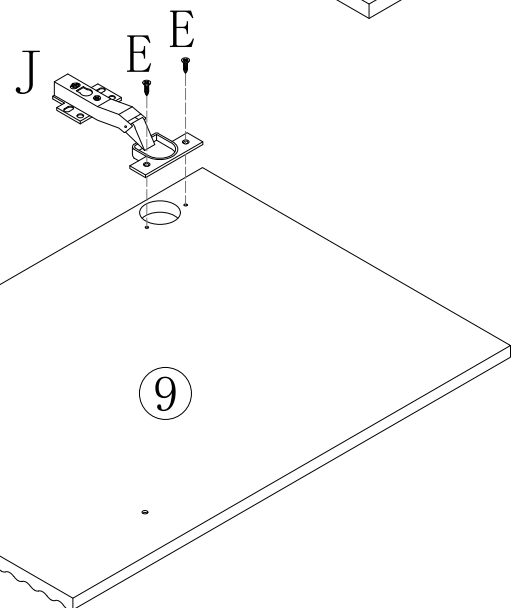
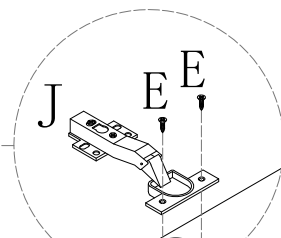
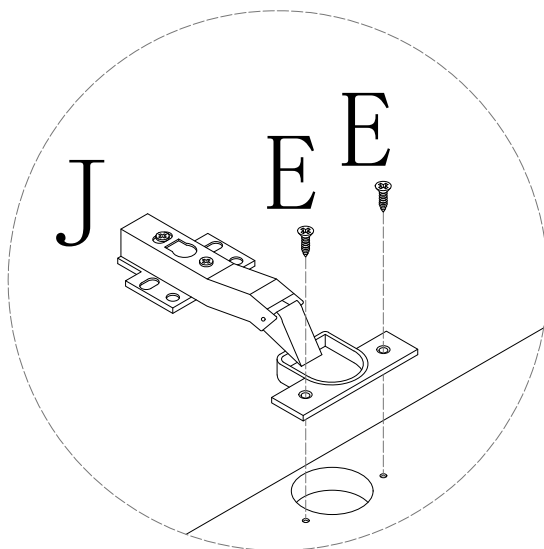
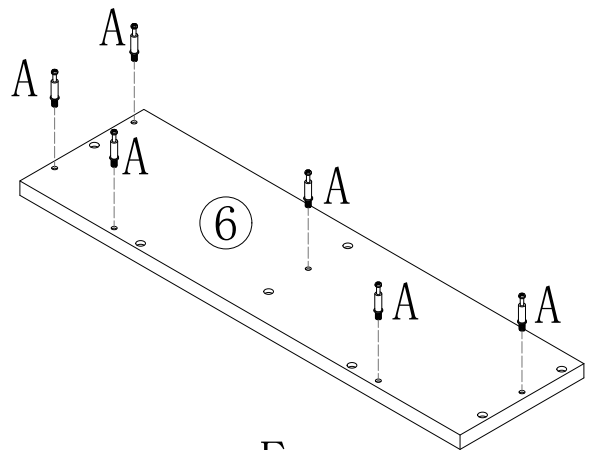
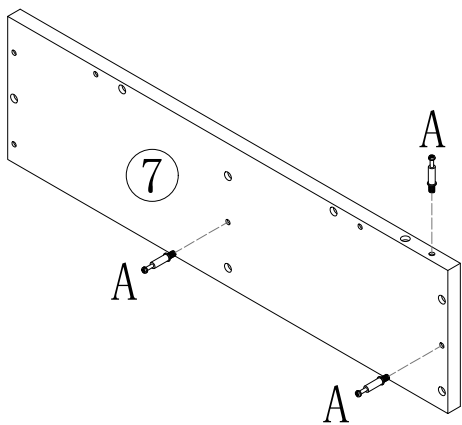
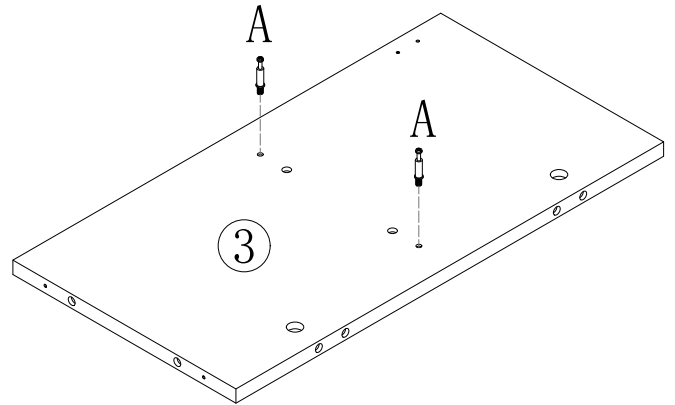
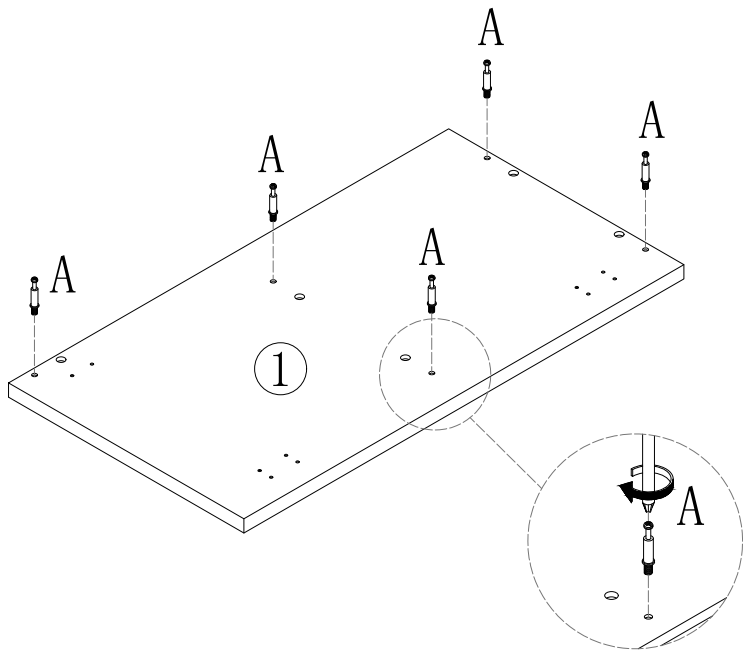
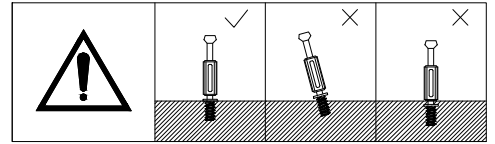
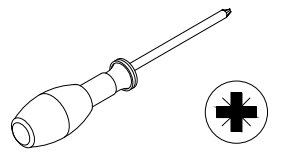
A * 16	E * 4	J * 2
		
M6 X 35mm	M4 x 14mm	Ø35



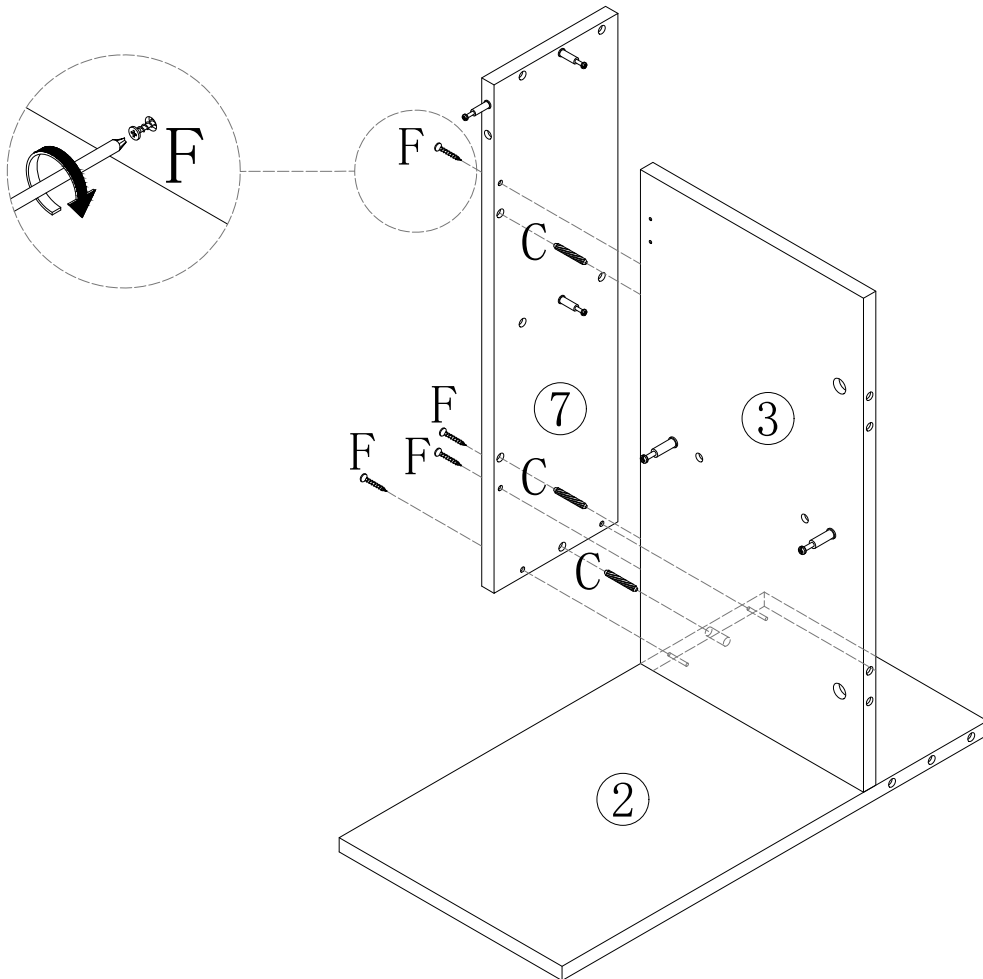
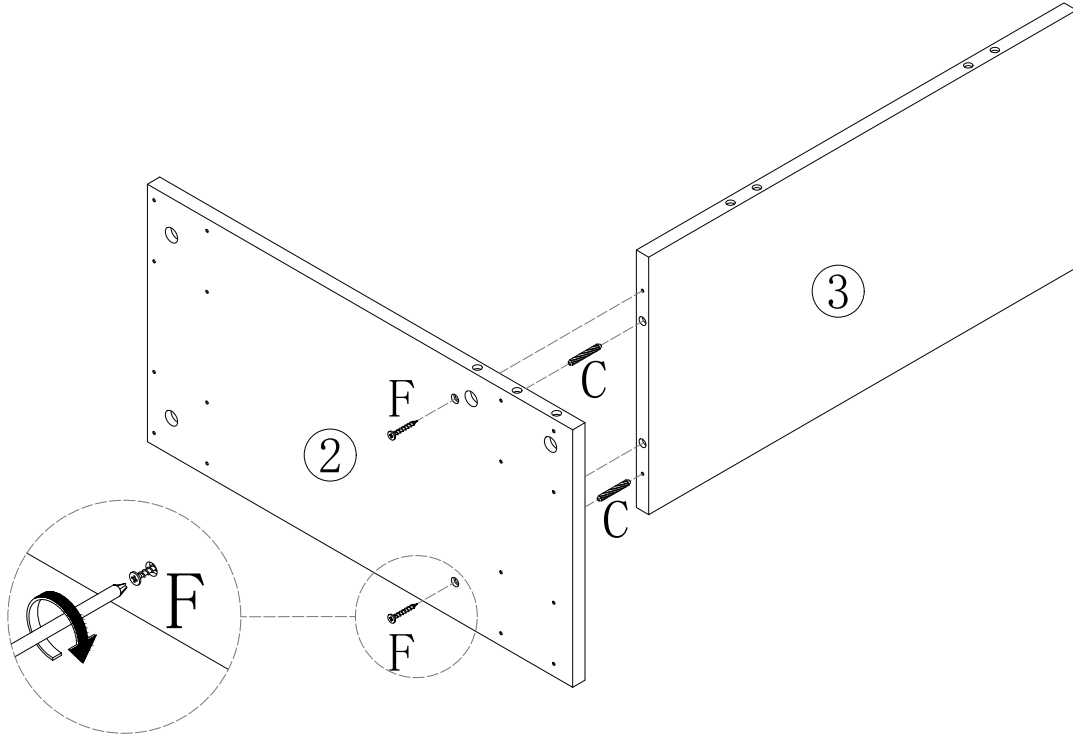
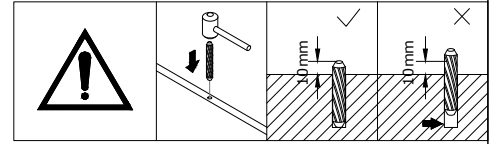
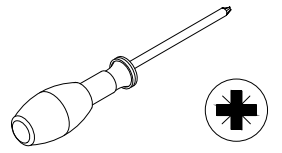

# Step 2

C * 5	F * 6
 Ø8 X 30mm	 M5 X 40mm



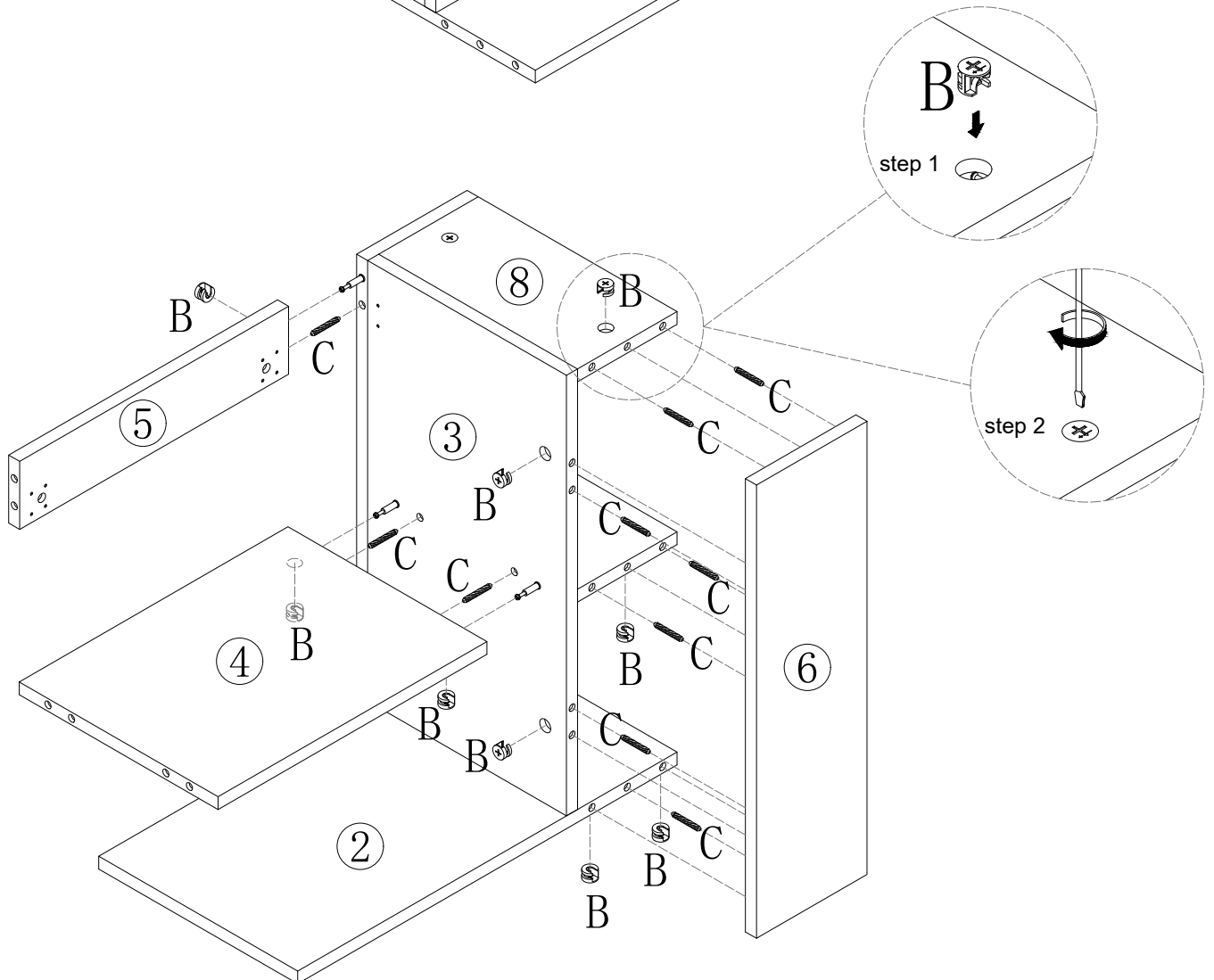
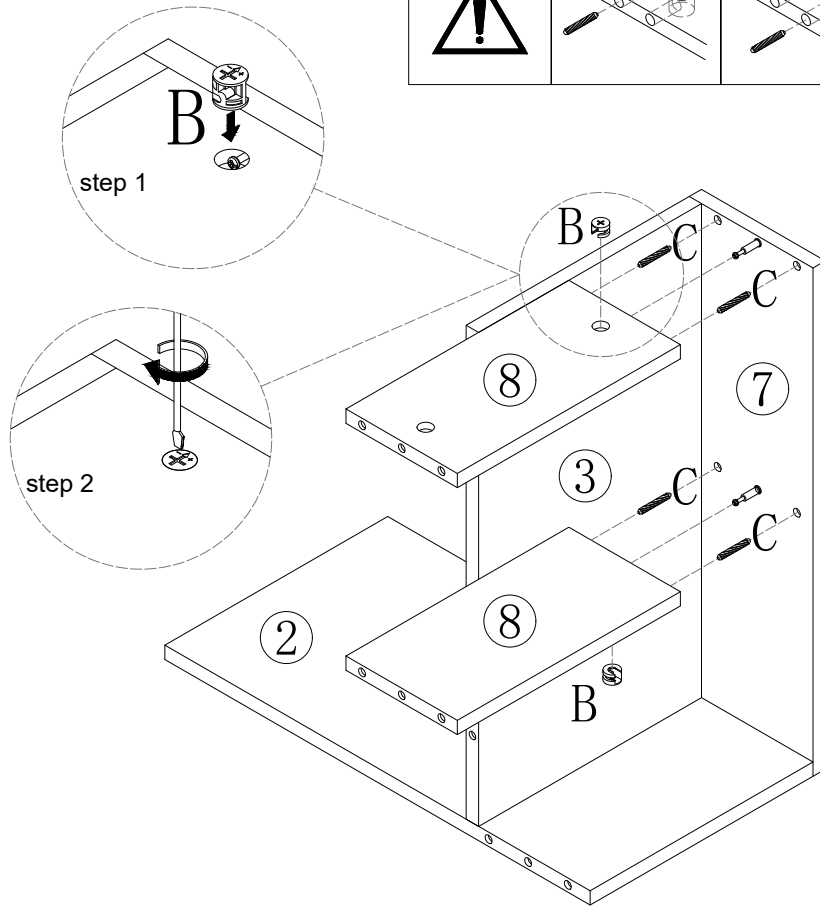
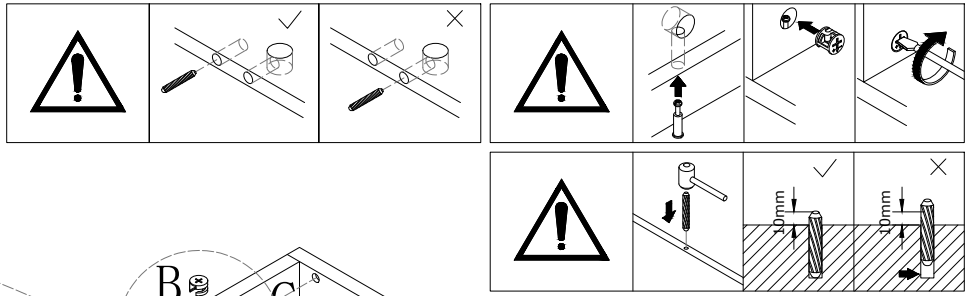
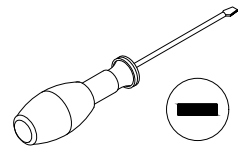

# Step 3

B * 11	C * 14
	
Ø15 x 12mm	Ø8 x 30mm



# Step 4

B * 5  Ø15 x 12mm	C * 5  Ø8 x 30mm
--	---

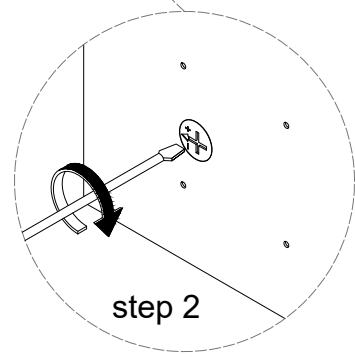
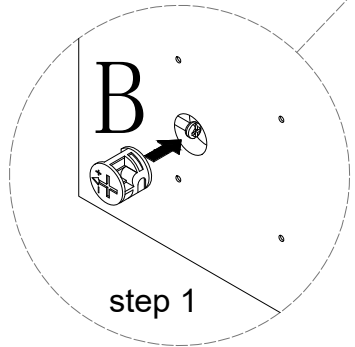
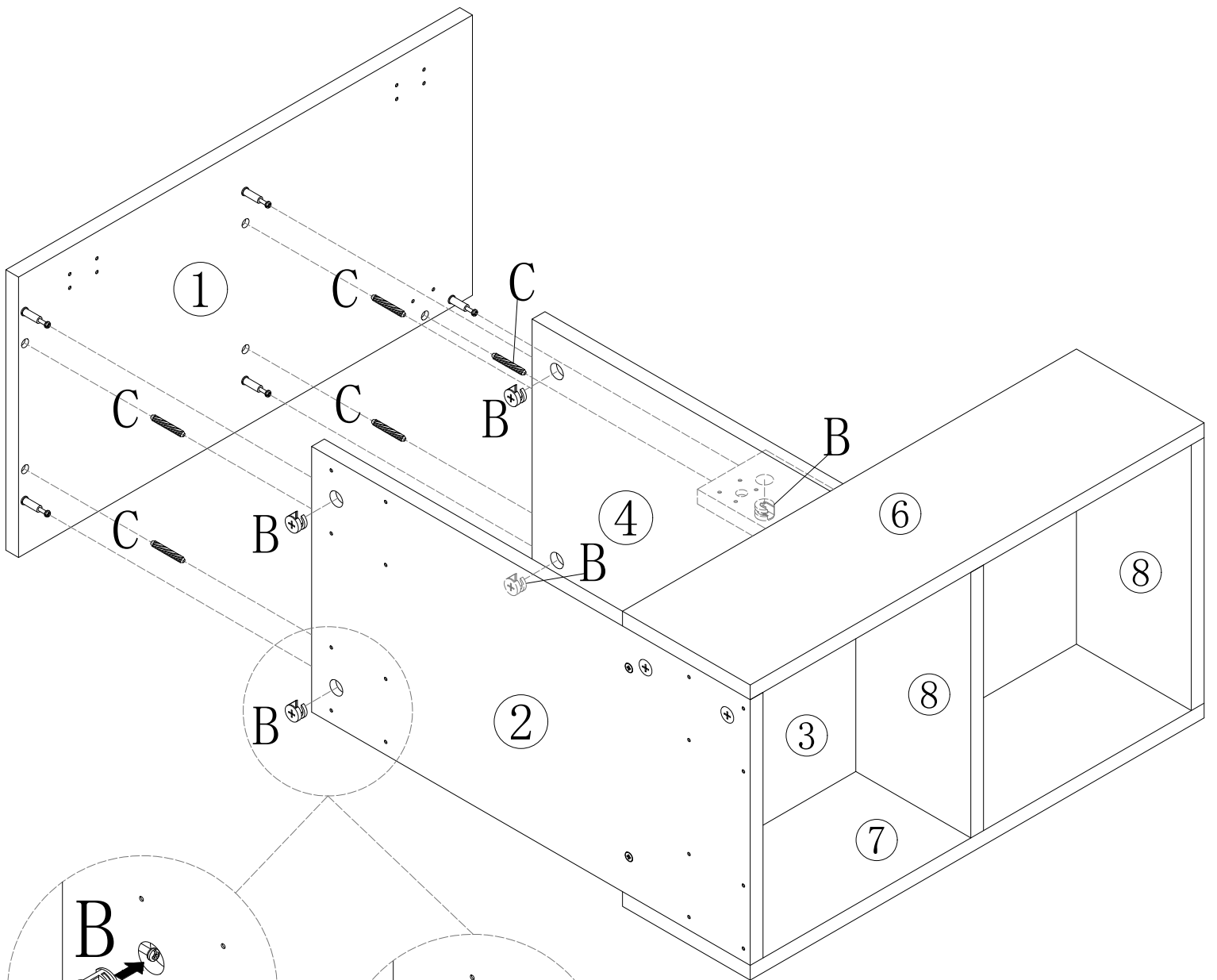
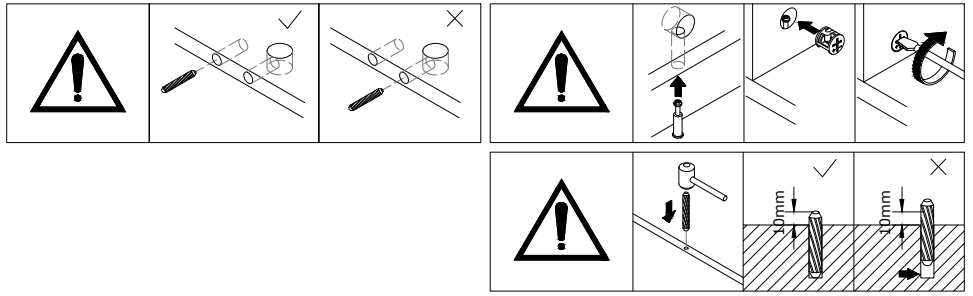
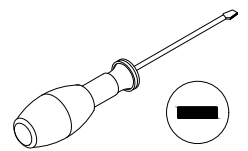

# Step 5



E \* 16

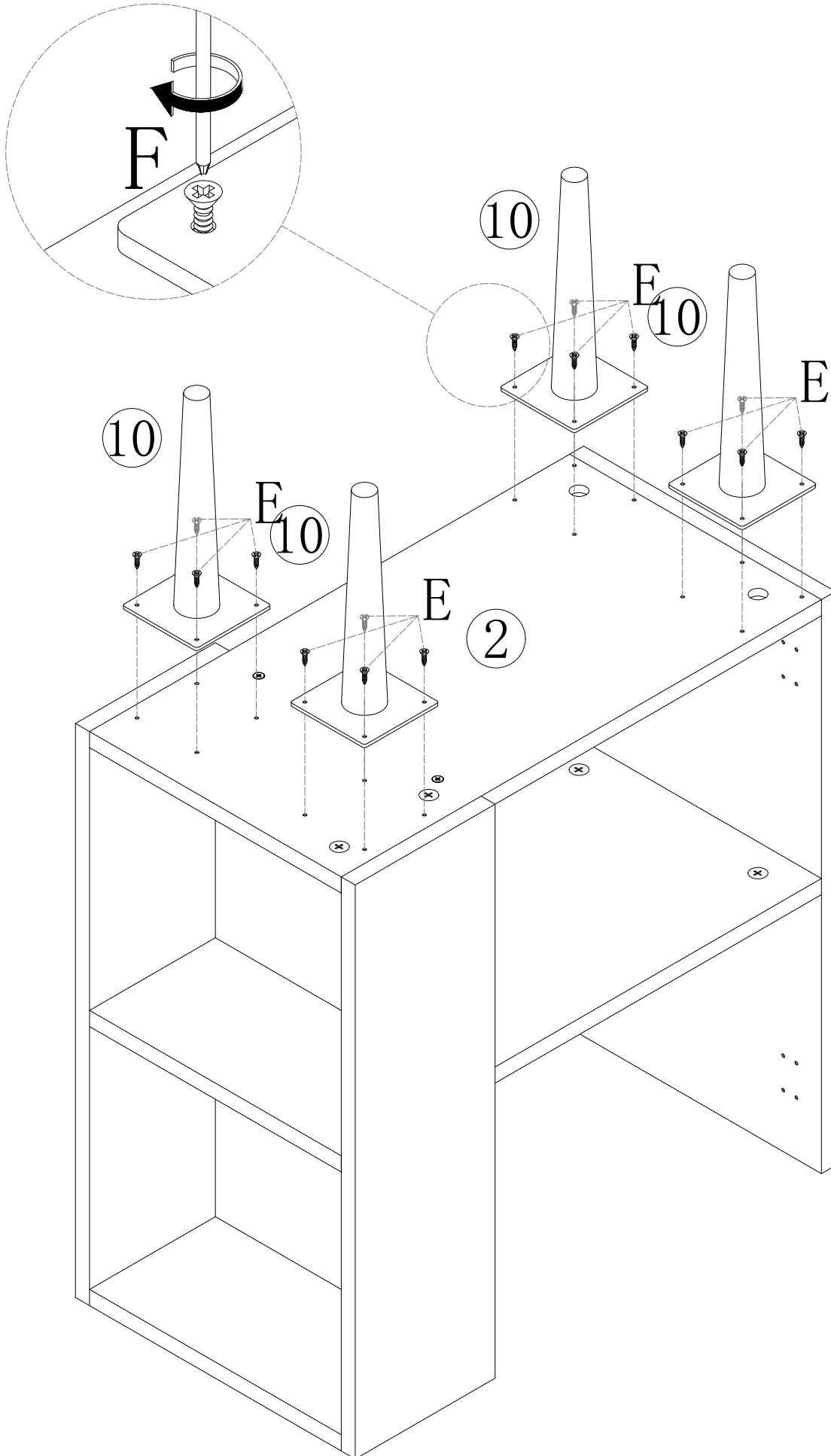
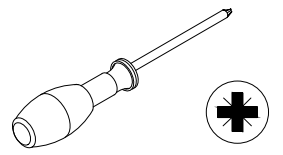

M4 x 14mm



# Step 6

D * 12	I * 2
 M4 x 14mm	

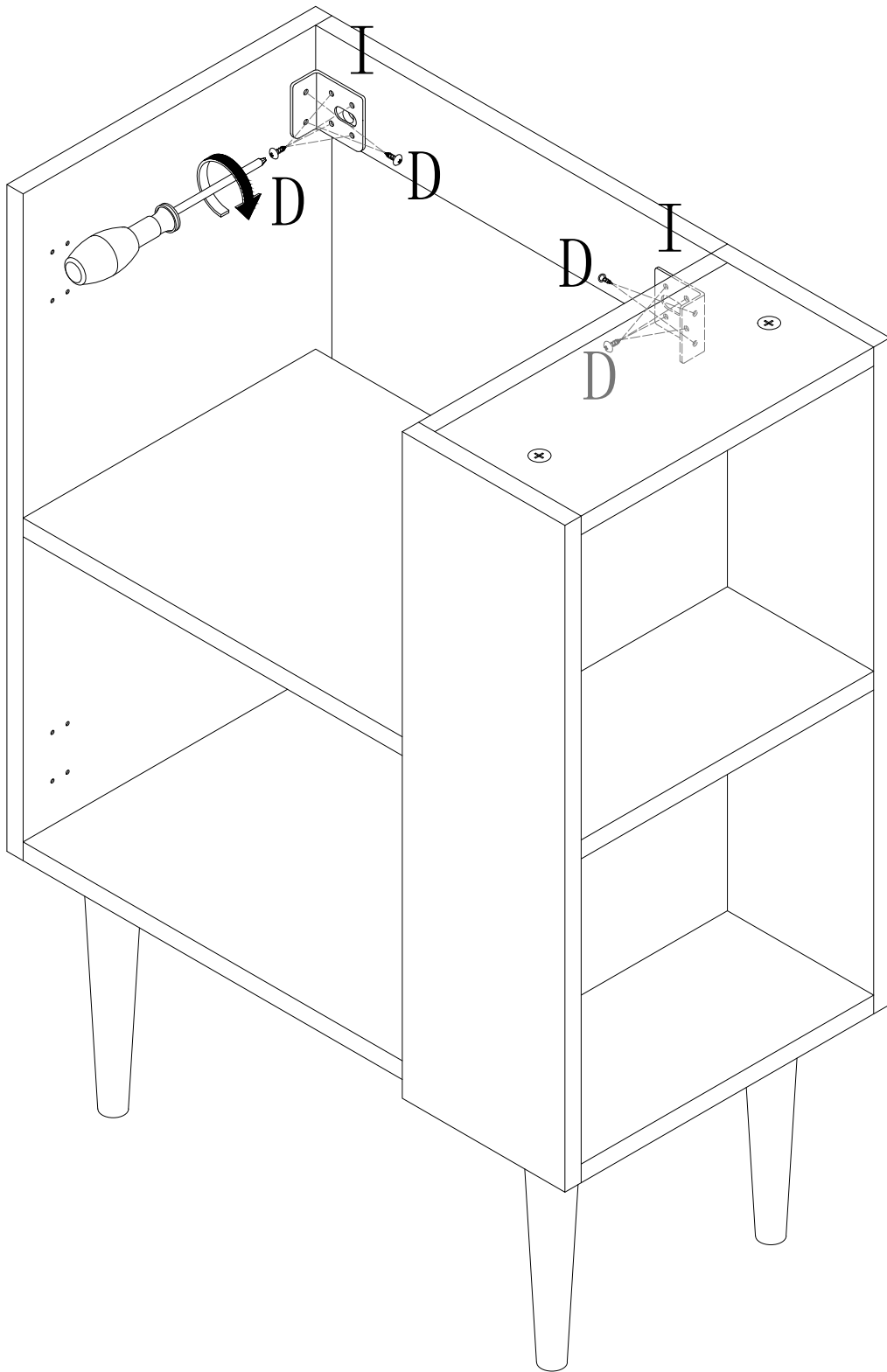
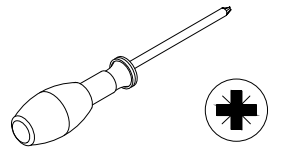

# Step 7

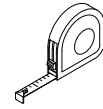
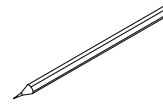

Wall

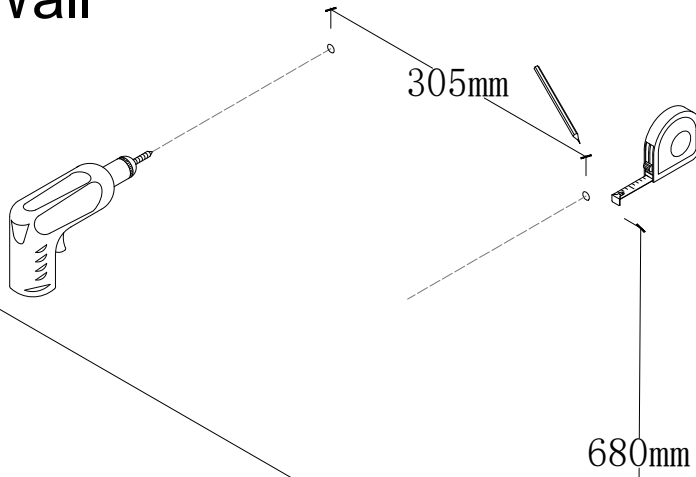

Please mark the location on the wall with a pencil, then punch the hole

# Setp 8

K * 2

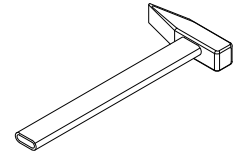
Ø8 x 40mm

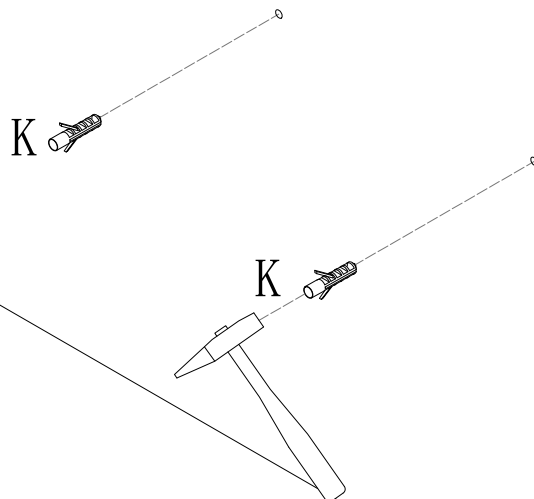

Wall

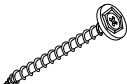

# Step 9

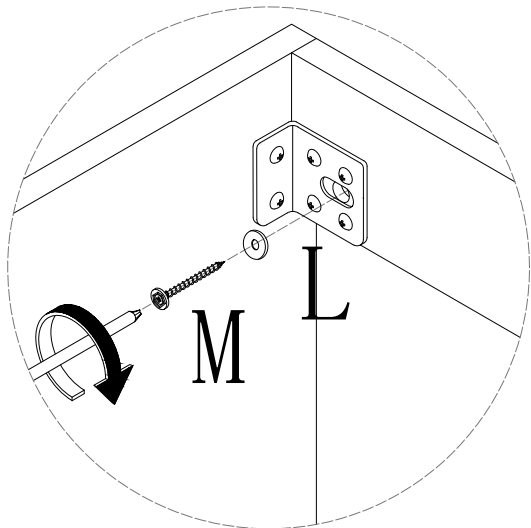
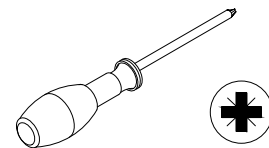

L * 2	M * 2
 Ø16	 M6 x 60mm

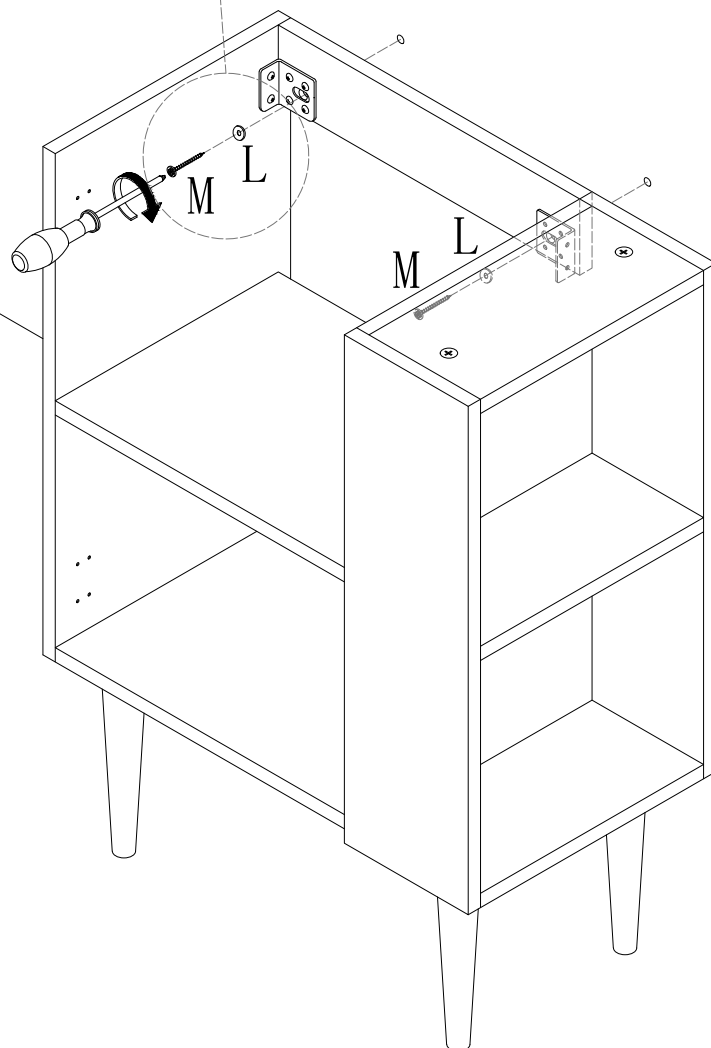

Wall



# Step 10

E * 8	G * 1	H * 1
 M4 x 14mm	 M4 x 20mm	

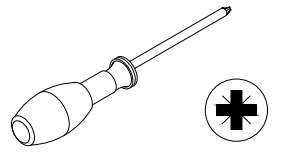

## Wall

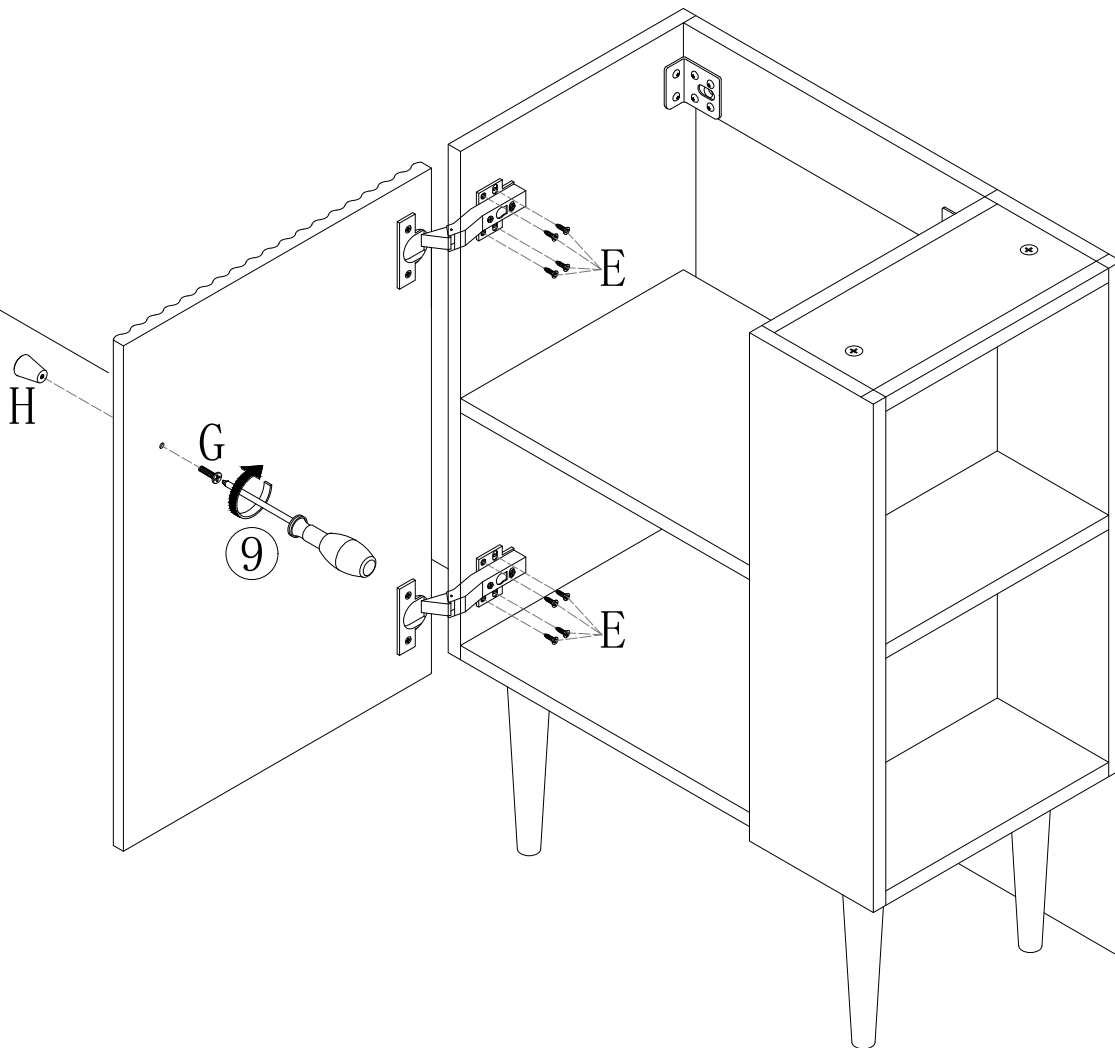

# Step 11

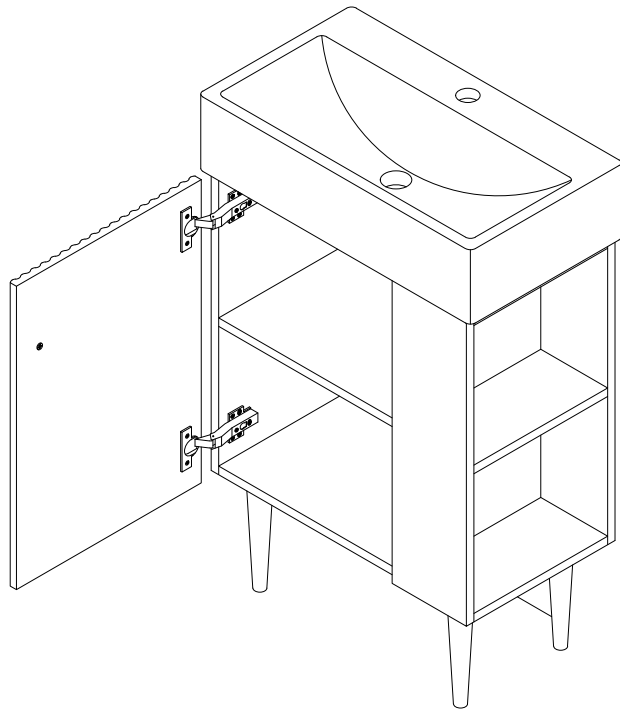
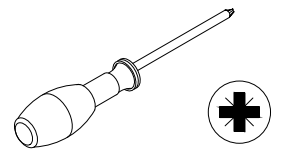

## Adjust door following the direction.

### Adjust the door up and down to match the cabinet.

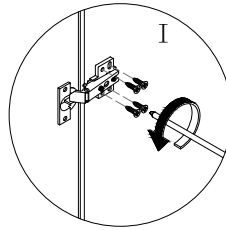

I:loosen the screw.

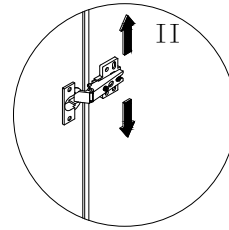

II:Adjust the upper and lower position.

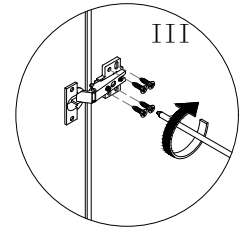

II:tighten the screw.



**When the door position is not standard,please adjust the door according to the right picture.**

### Adjust the door left and right to match the cabinet for suitable crack of the door

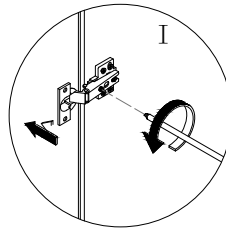

I:loosen the screw to keep hinge apply force toward the direction of arrow.

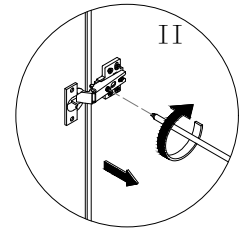

II:tighten the screw to keep hinge apply force toward the direction of arrow.



**Please place the cabinet on the flat floor before adjustment.**

### Adjust the door backwards and forwards to match the cabinet.

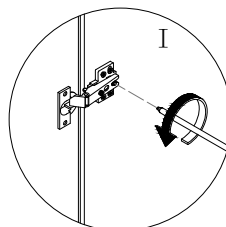

I:loosen the screw.

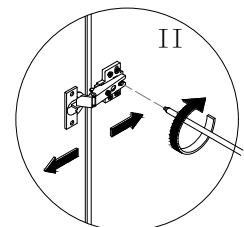

II:Adjust the distance between front and back.

# Step 12

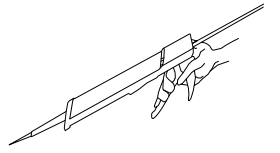

## Wall

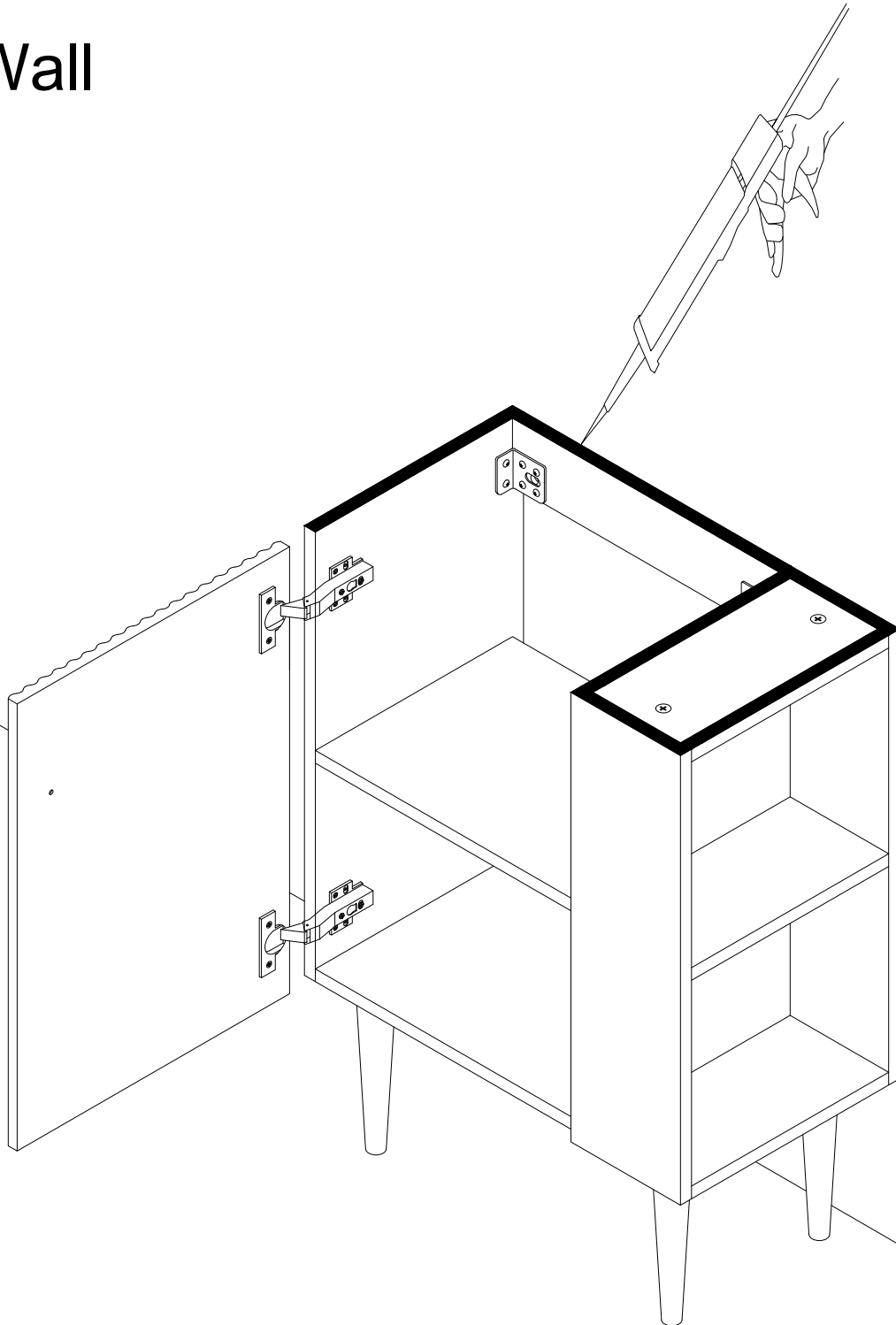

# Step 13

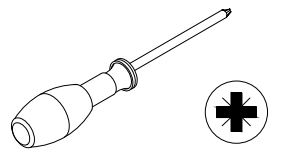

Wall

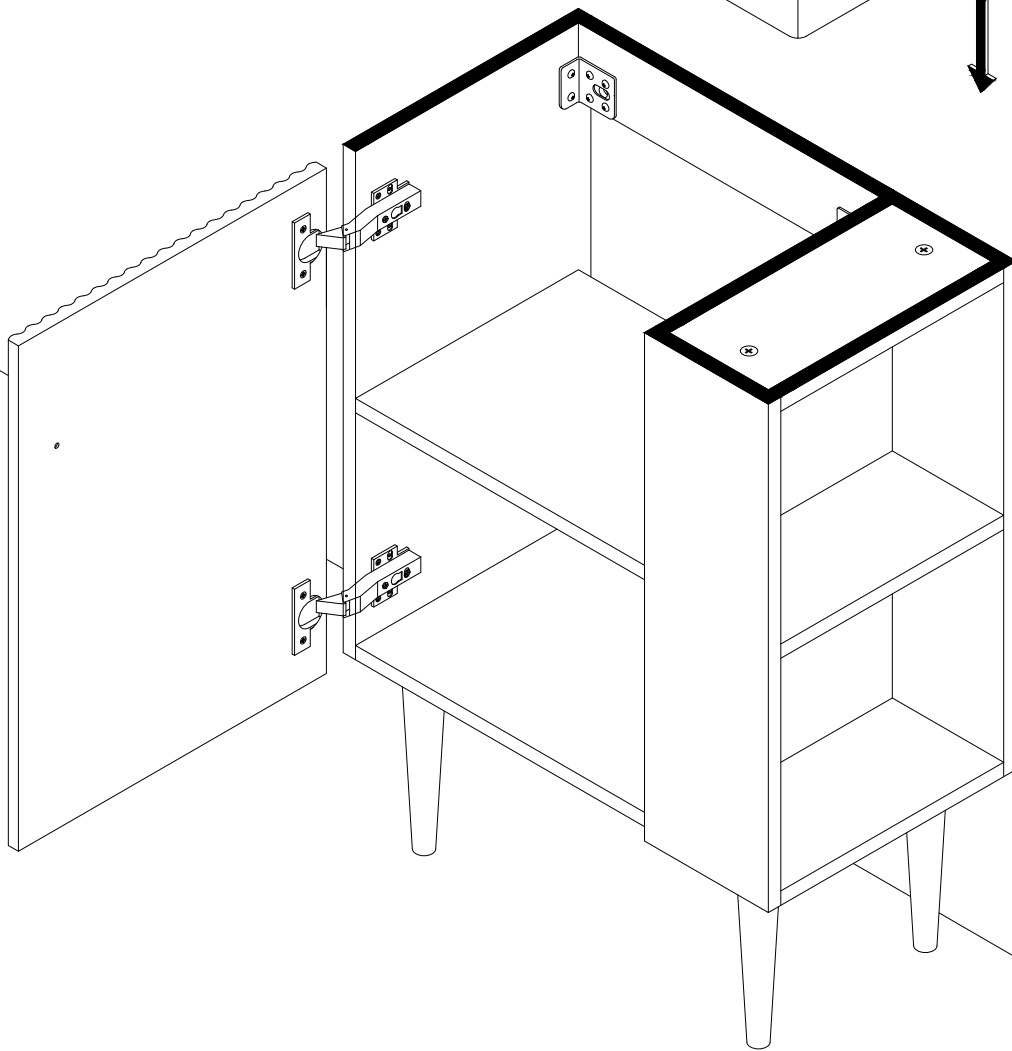
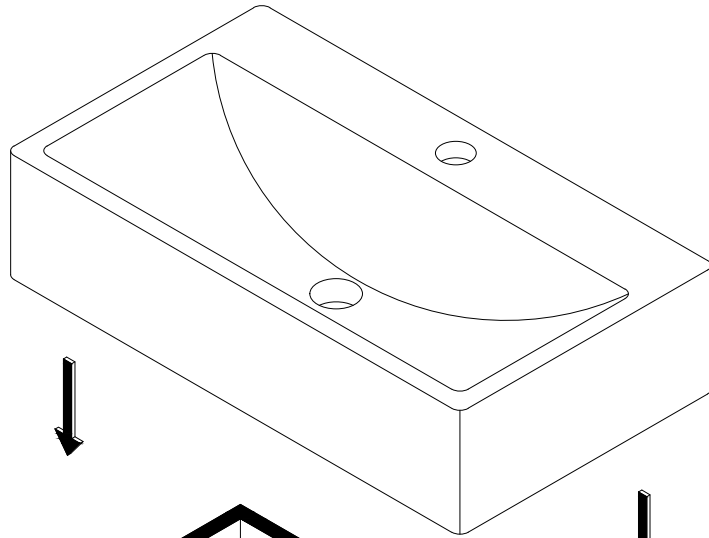

# Step 14

