

## CARE AND MAINTENANCE

Store outdoor furniture indoors or cover well when not in use.  
Remove wooden furniture from standing water. Dust regularly with small brush or vacuum  
Spills should be taken care of immediately before they harden or stain with a slightly dampened sponge.

## NOTICE

- \* Please make sure that you have all parts indicated before you begin assembly of this item
- \* This item should be assembled on a soft surface to prevent scratching the finish during assembly
- \* This item may require periodic tightening

**Weight Capacity : 275 lbs (single seat)  
550 lbs (two person seat)**

**Warning : Do not stand on bench**

**Warning : Do not over torque bolts/screws**



## Part List and Hardware List

| PIECE | DESCRIPTION          | PICTURE | QUANTITY |
|-------|----------------------|---------|----------|
| 1     | Right Back Frame     |         | 3X       |
| 2     | Left Back Frame      |         | 3X       |
| 3     | Right Seat Frame     |         | 3X       |
| 4     | Left Seat Frame      |         | 3X       |
| 5     | Right Side Frame     |         | 3X       |
| 6     | Left Side Frame      |         | 3X       |
| 7     | Bare Frame           |         | 3X       |
| 8     | Right Panel Frame    |         | 3X       |
| 9     | Left Panel Frame     |         | 3X       |
| 10    | Table                |         | 1X       |
| 11    | Seat cushion         |         | 6X       |
| 12    | Back cushion         |         | 6X       |
| 13    | Table Glass          |         | 1X       |
| 14    | Pillow cushion       |         | 3X       |
| A     | Allen bolt(M6x20 mm) |         | 6X       |
| B     | Allen bolt(M6x30 mm) |         | 48X      |
| C     | Allen bolt(M6x40 mm) |         | 18X      |
| D     | Allen bolt(M6x60 mm) |         | 12X      |
| E     | Flat Washer          |         | 96X      |
| F     | Allen Key            |         | 3X       |
| G     | Pat                  |         | 3X       |

Product Dimensions:  
31.50"x31.50"x 16.14" H (Table)  
63.78" x 37.40" x 29.92" H (Bench)

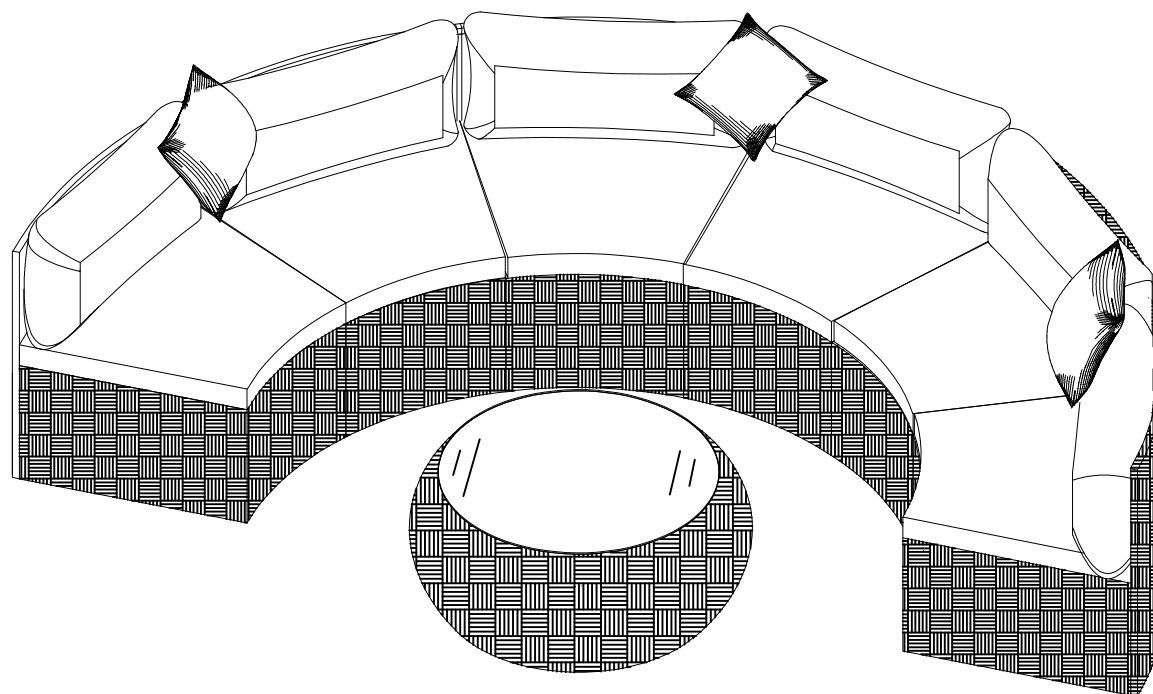

## CARE AND MAINTENANCE

Store outdoor furniture indoors or cover well when not in use.  
Remove wooden furniture from standing water. Dust regularly with small brush or vacuum  
Spills should be taken care of immediately before they harden or stain with a slightly dampened sponge.

## NOTICE

- \* Please make sure that you have all parts indicated before you begin assembly of this item
- \* This item should be assembled on a soft surface to prevent scratching the finish during assembly
- \* This item may require periodic tightening

**Weight Capacity : 275 lbs (single seat)  
550 lbs (two person seat)**

**Warning : Do not stand on bench**

**Warning : Do not over torque bolts/screws**



## Part List and Hardware List

| PIECE | DESCRIPTION          | PICTURE | QUANTITY |
|-------|----------------------|---------|----------|
| 1     | Right Back Frame     |         | 1X       |
| 2     | Left Back Frame      |         | 1X       |
| 3     | Right Seat Frame     |         | 1X       |
| 4     | Left Seat Frame      |         | 1X       |
| 5     | Right Side Frame     |         | 1X       |
| 6     | Left Side Frame      |         | 1X       |
| 7     | Bare Frame           |         | 1X       |
| 8     | Right Panel Frame    |         | 1X       |
| 9     | Left Panel Frame     |         | 1X       |
| 11    | Seat cushion         |         | 2X       |
| 12    | Back cushion         |         | 2X       |
| 14    | Pillow cushion       |         | 2X       |
| A     | Allen bolt(M6x20 mm) |         | 2X       |
| B     | Allen bolt(M6x30 mm) |         | 16X      |
| C     | Allen bolt(M6x40 mm) |         | 6X       |
| D     | Allen bolt(M6x60 mm) |         | 4X       |
| E     | Flat Washer          |         | 32X      |
| F     | Allen Key            |         | 1X       |
| G     | Pat                  |         | 1X       |

Product Dimensions:  
63.78" x 37.40" x 29.92" H (Bench)

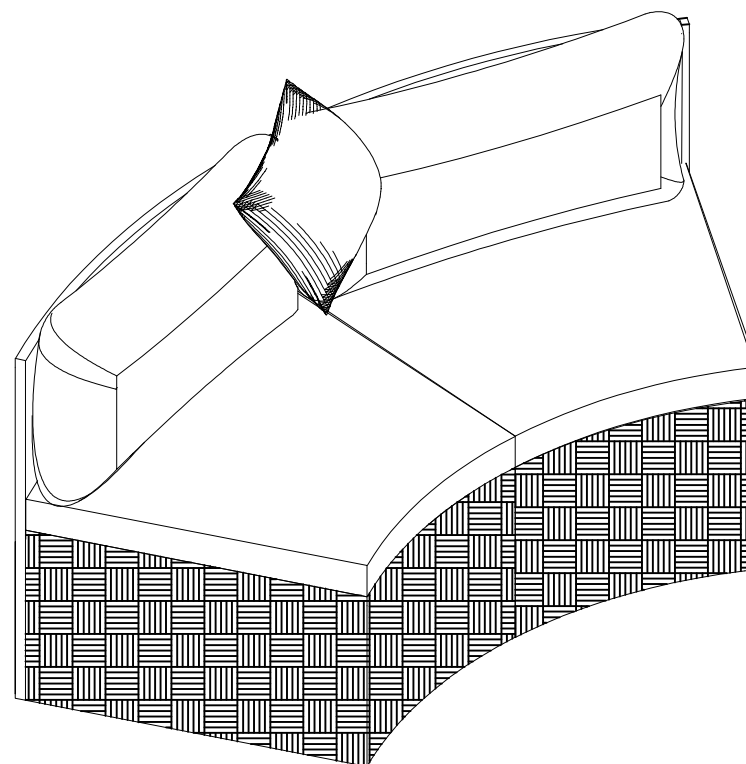

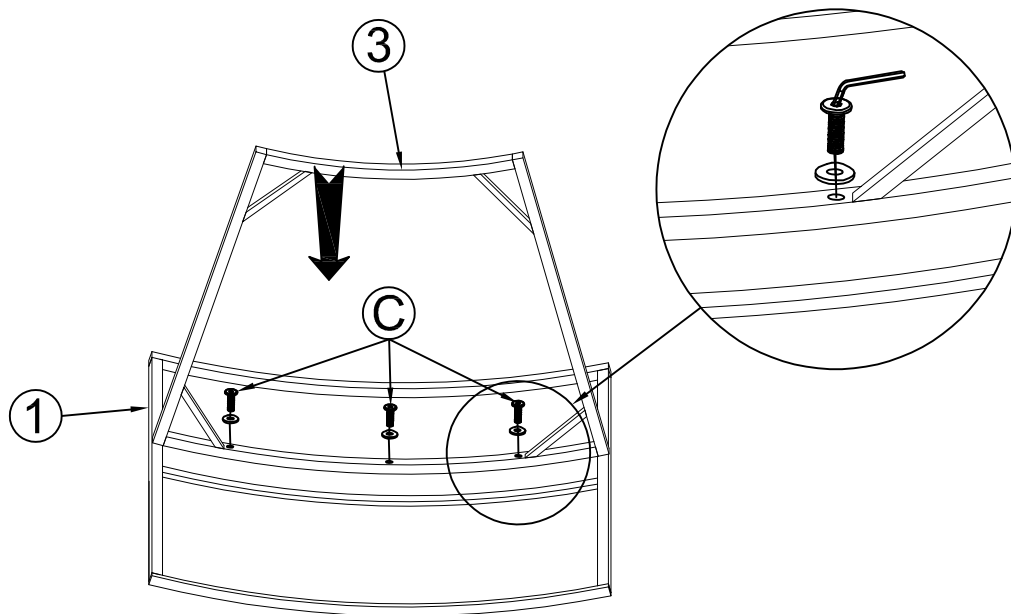

STEP 1: Connect Right Back Frame (1) and Right Seat Frame (3), tighten Allen Bolt (C), Flat Washer (E) with Allen Key (F).

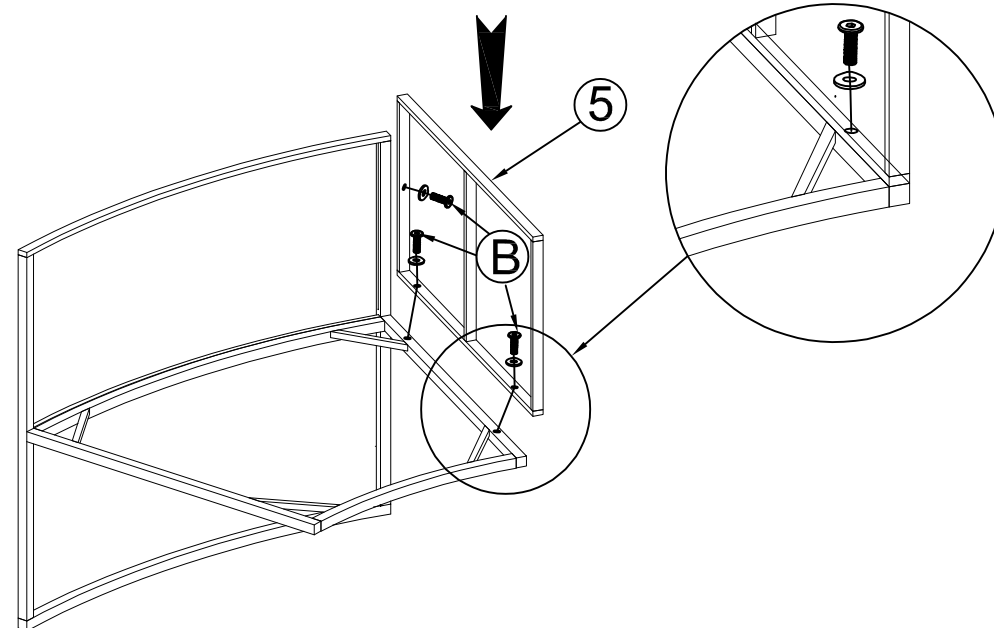

STEP 2: Connect The part from STEP 1 & Right Side Frame (5), tighten Allen Bolt (B), Flat Washer (E) with Allen Key (F).

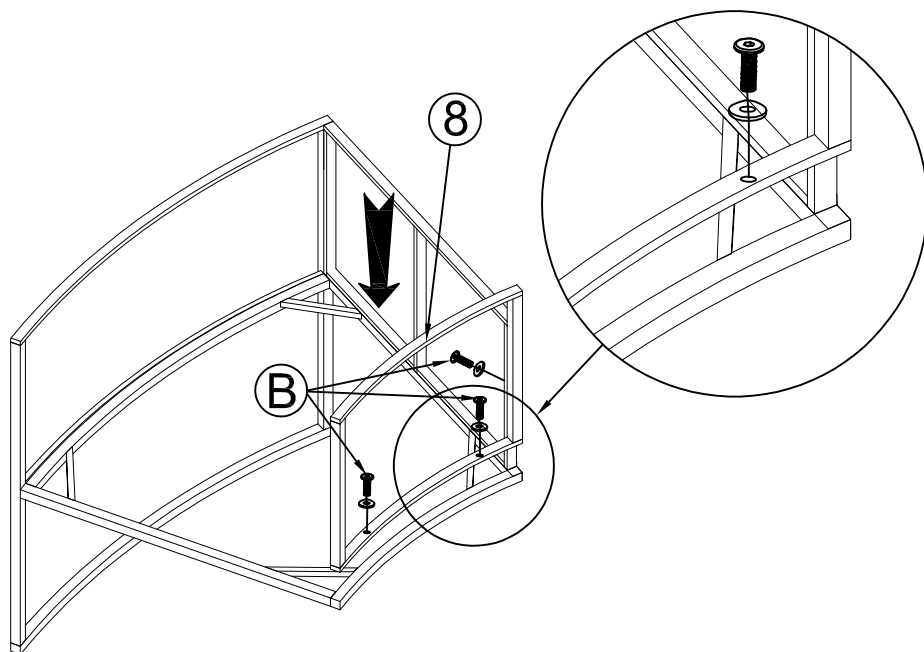

STEP 3: Connect The part from STEP 2 & Right Panel Frame (8), tighten Allen Bolt (8), Flat Washer (E) with Allen Key (F) to finish Right Chair.

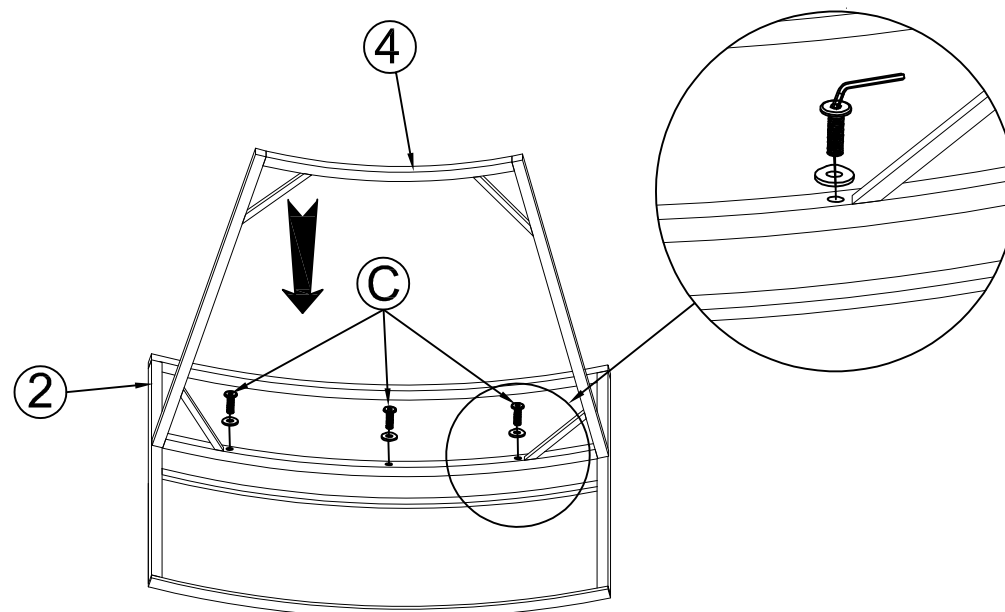

STEP 4: Connect Left Back Frame (2) & Left Seat Frame (4), tighten Allen Bolt (C), Flat Washer (E) with Allen Key (H).

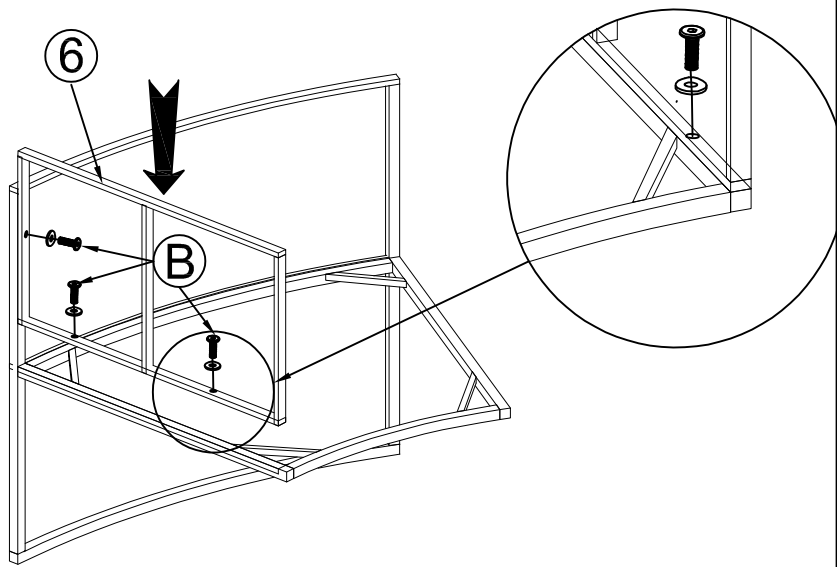

STEP 5: Connect The part from STEP (4) & Left Side Frame (6), tighten Allen Bolt (B), Flat Washer (E) with Allen Key (H).

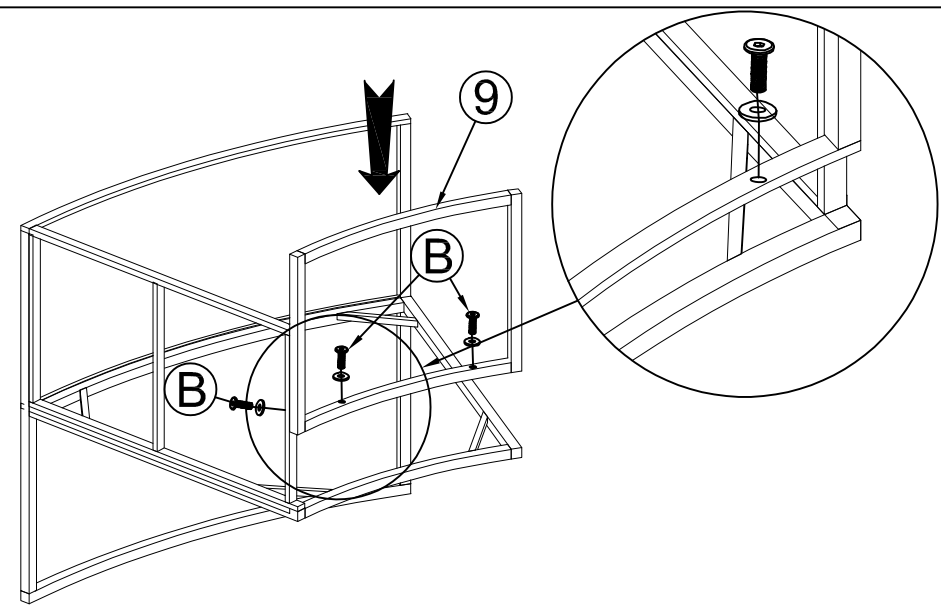

STEP 6: Connect The part from STEP (5) & Left Panel Frame (9), tighten Allen Bolt (B), Flat Washer (E) with Allen Key (H) to finish Left Chair.

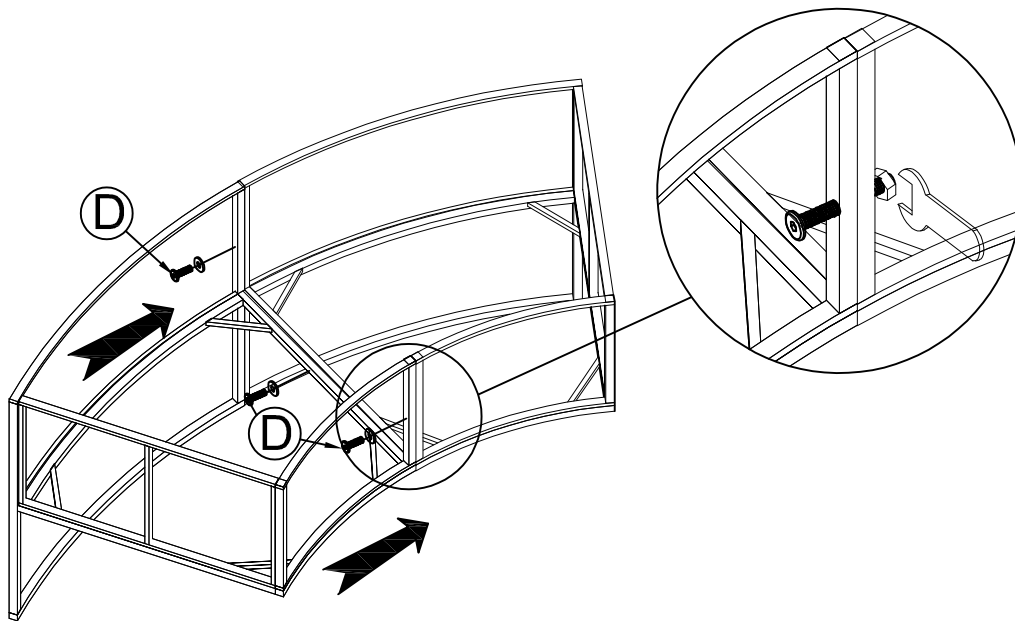

STEP 7: Connect The part from STEP 3 (Right Chair) & The part from STEP 6 (Left Chair), tighten Allen Bolt (D), Ecrú with Key (D).

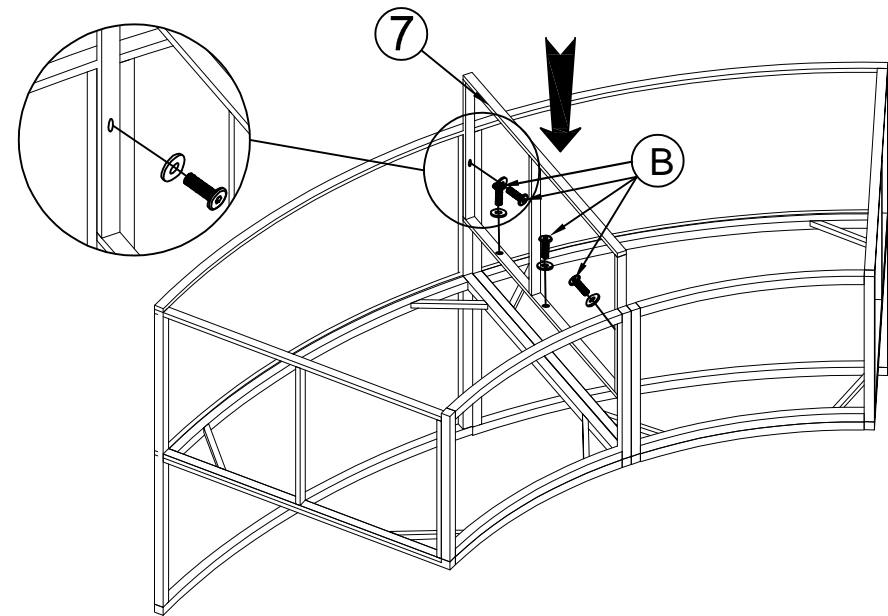

STEP 8: Connect The part from STEP 7 & Bare Frame (7), tighten Allen Bolt (B), Flat Washer (E) with Allen Key (F).

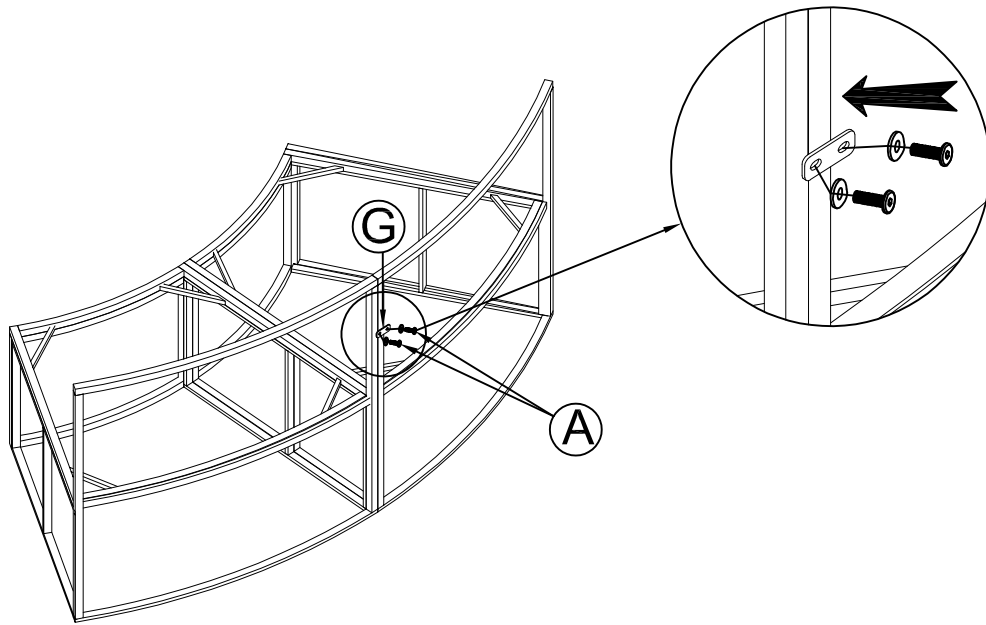

STEP 9: Connect The Part from STEP 8 & PAT (G), tighten Allen Bolt (A), Flat Washer (E) with Allen Key (F).

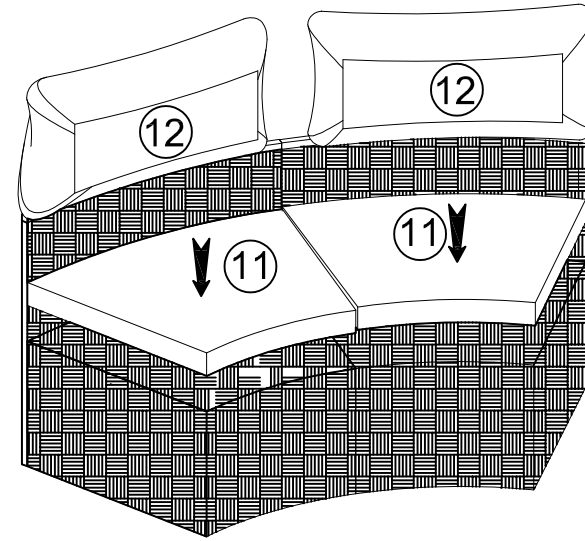

STEP 10: Put on Back Cushion (12) & Seat Cushion (11) to finish Bench.

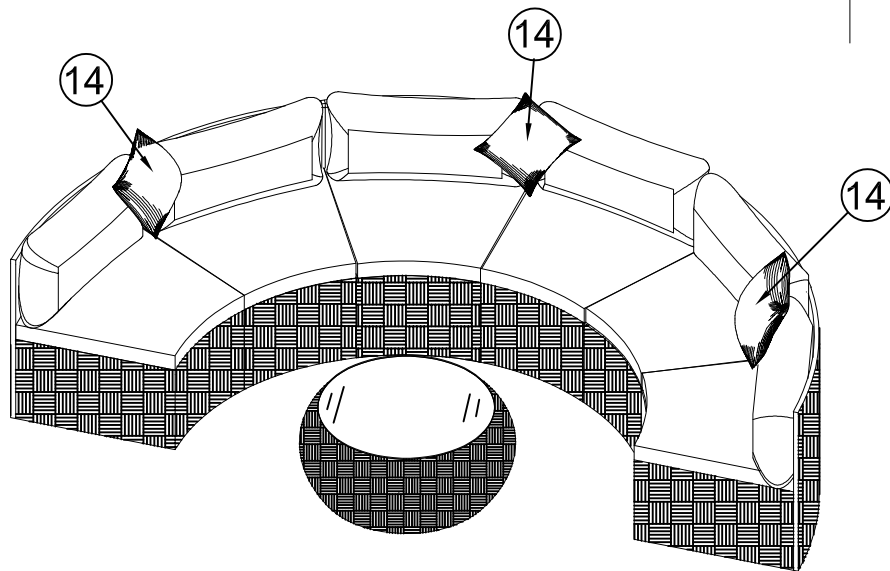

STEP 11: Put Pillow (14) on Bench to finish Bench.

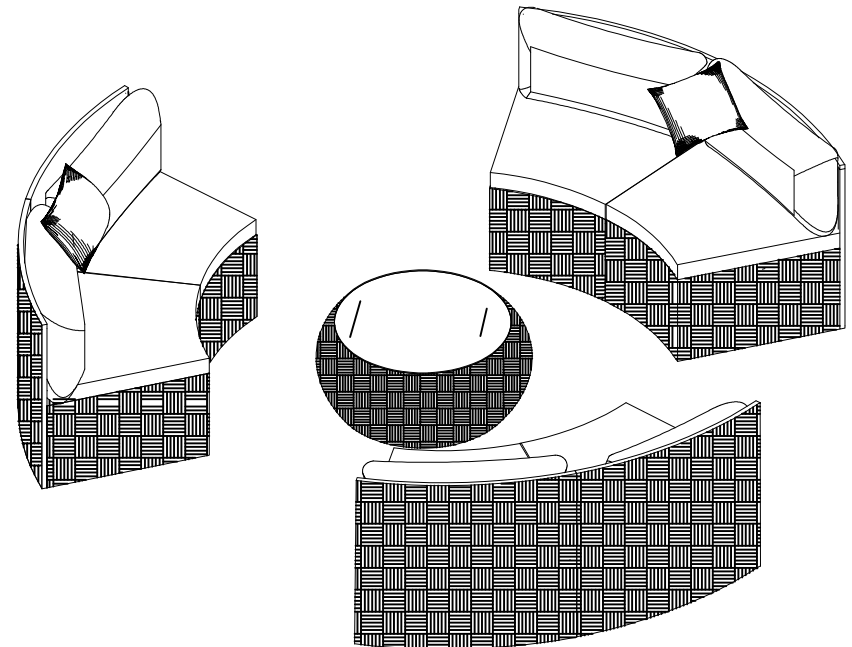

OTHER OPTION