

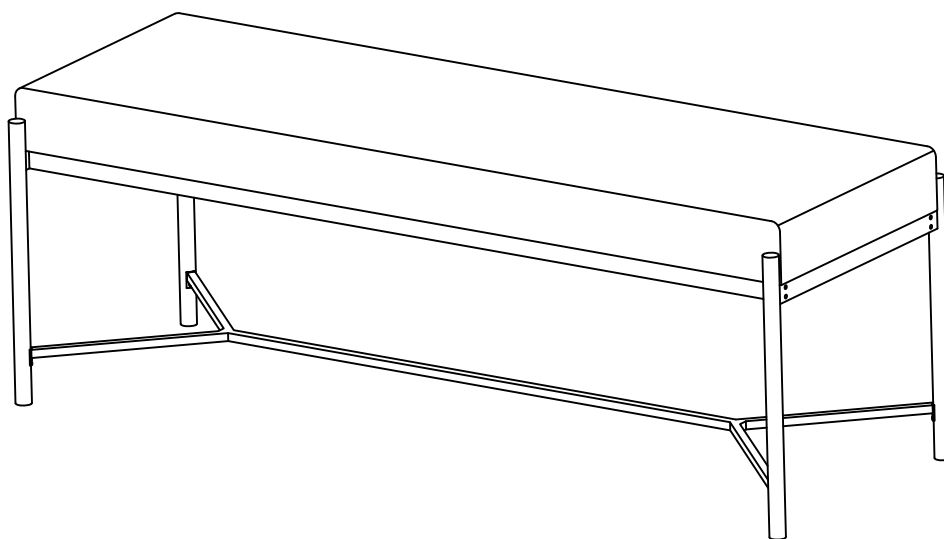

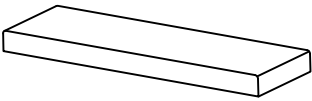

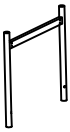

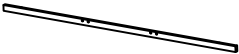

ASSEMBLY INSTRUCTION

SHOE BENCH — BH0004



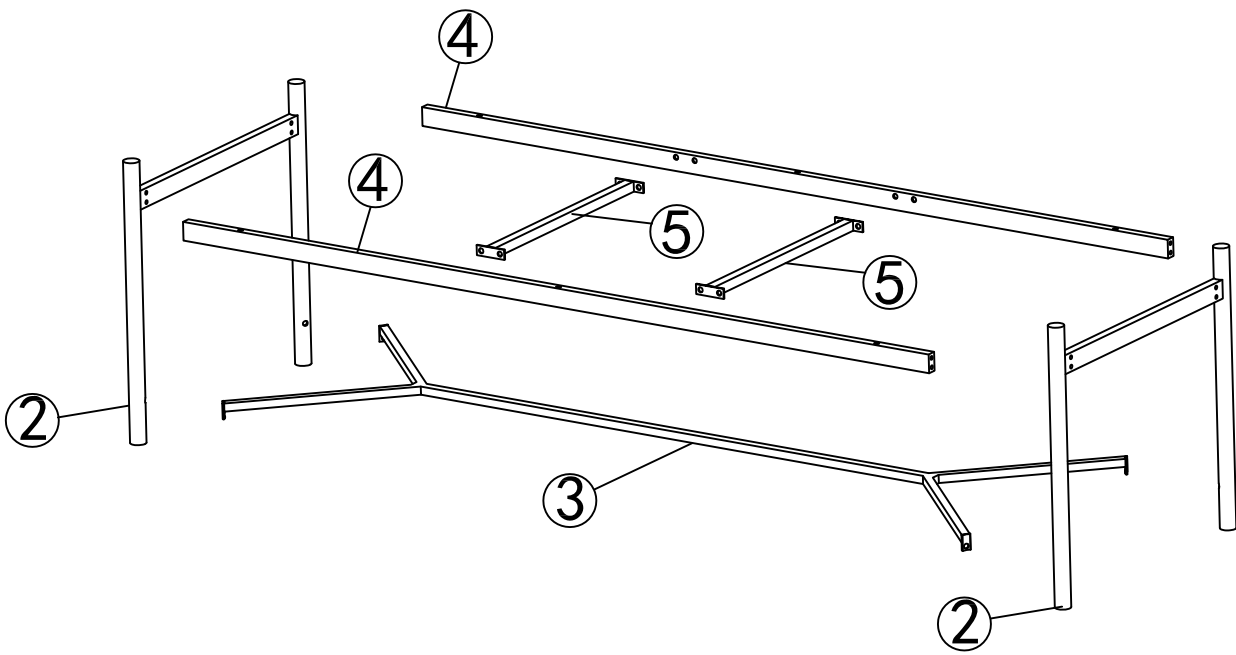
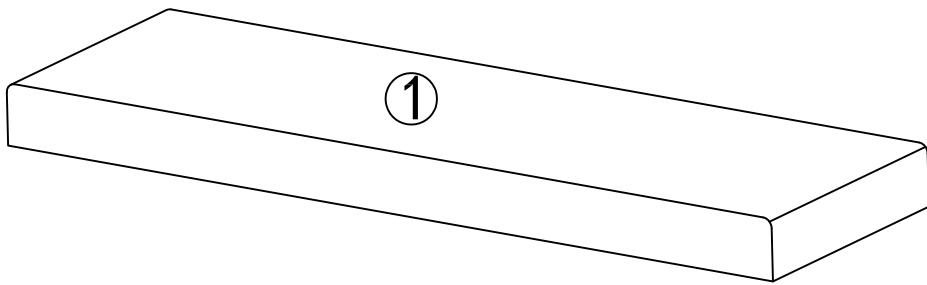

<p>①</p>  <p>X1PC</p>	<p>②</p>  <p>X2PCS</p>	<p>③</p>  <p>X1PC</p>	<p>④</p>  <p>X2PCS</p>	<p>⑤</p>  <p>X2PCS</p>
<p>A</p>  <p>M6X12</p> <p>X12PCS</p>	<p>B</p>  <p>M6*30</p> <p>X8PCS</p>	<p>C</p>  <p>M6*50</p> <p>X6PCS</p>	<p>D</p>  <p>X1PC</p>	



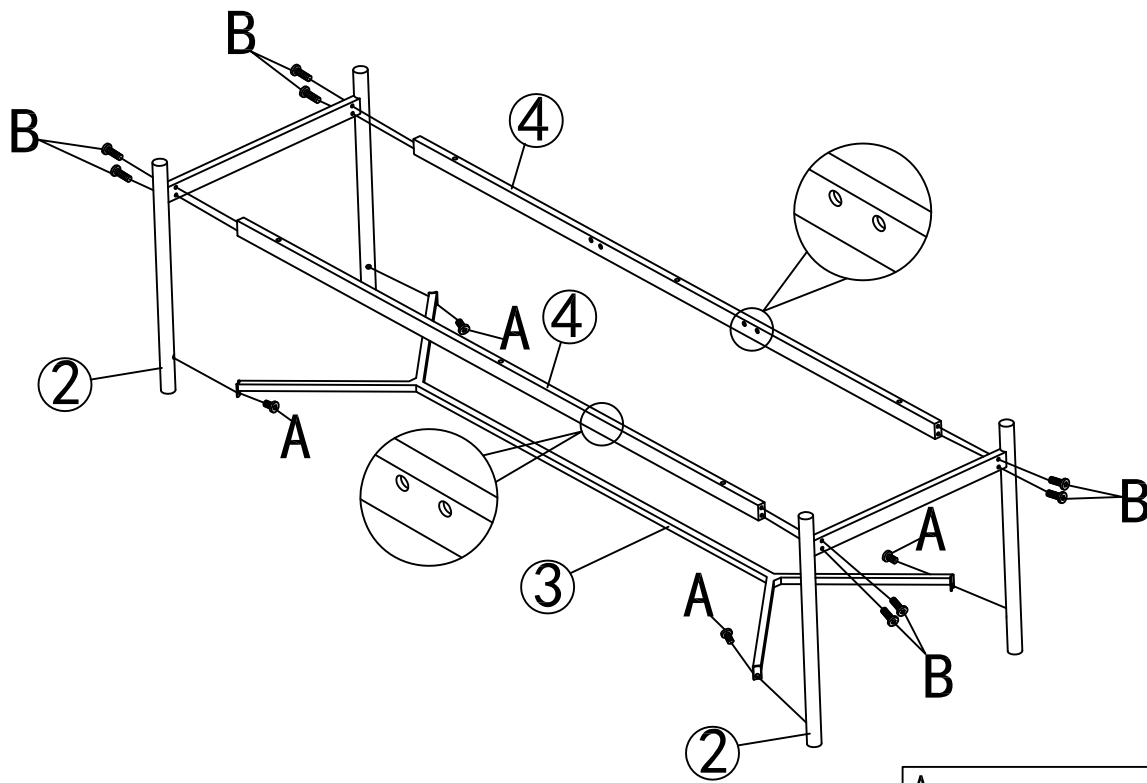

STEP1 :

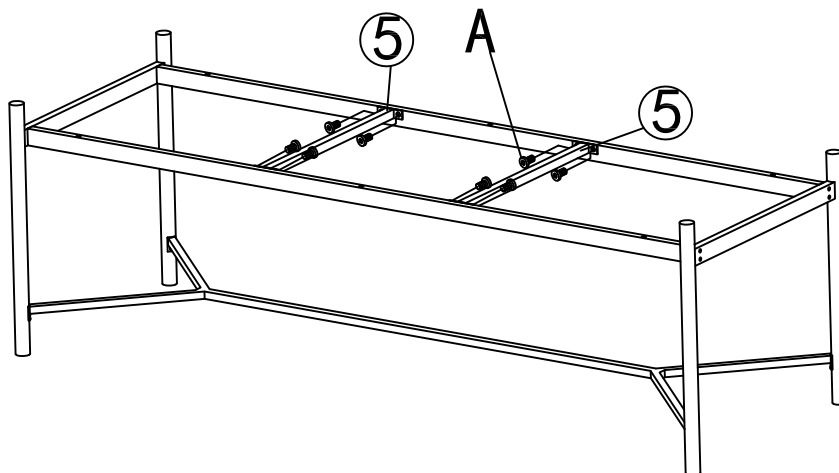

A	 M6*12 X4PCS	B	 M6*30 X8PCS
---	--------------------------------------------------------------------------------------------------------	---	--------------------------------------------------------------------------------------------------------

STEP2 :



A	 M6*12 X8PCS
---	---------------------------------------------------------------------------------------------------------

STEP3:

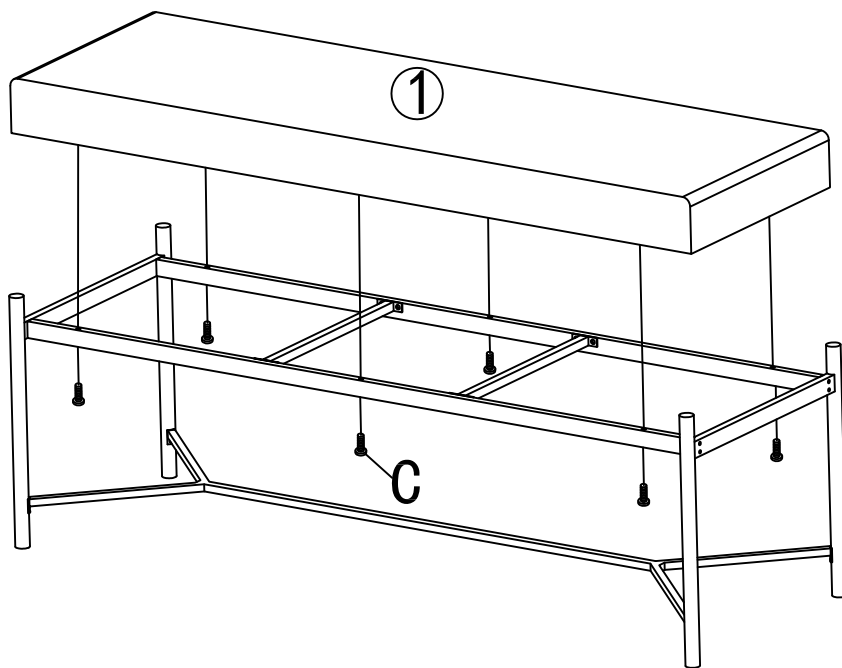

C



M6*50
X6PCS

STEP4:

