

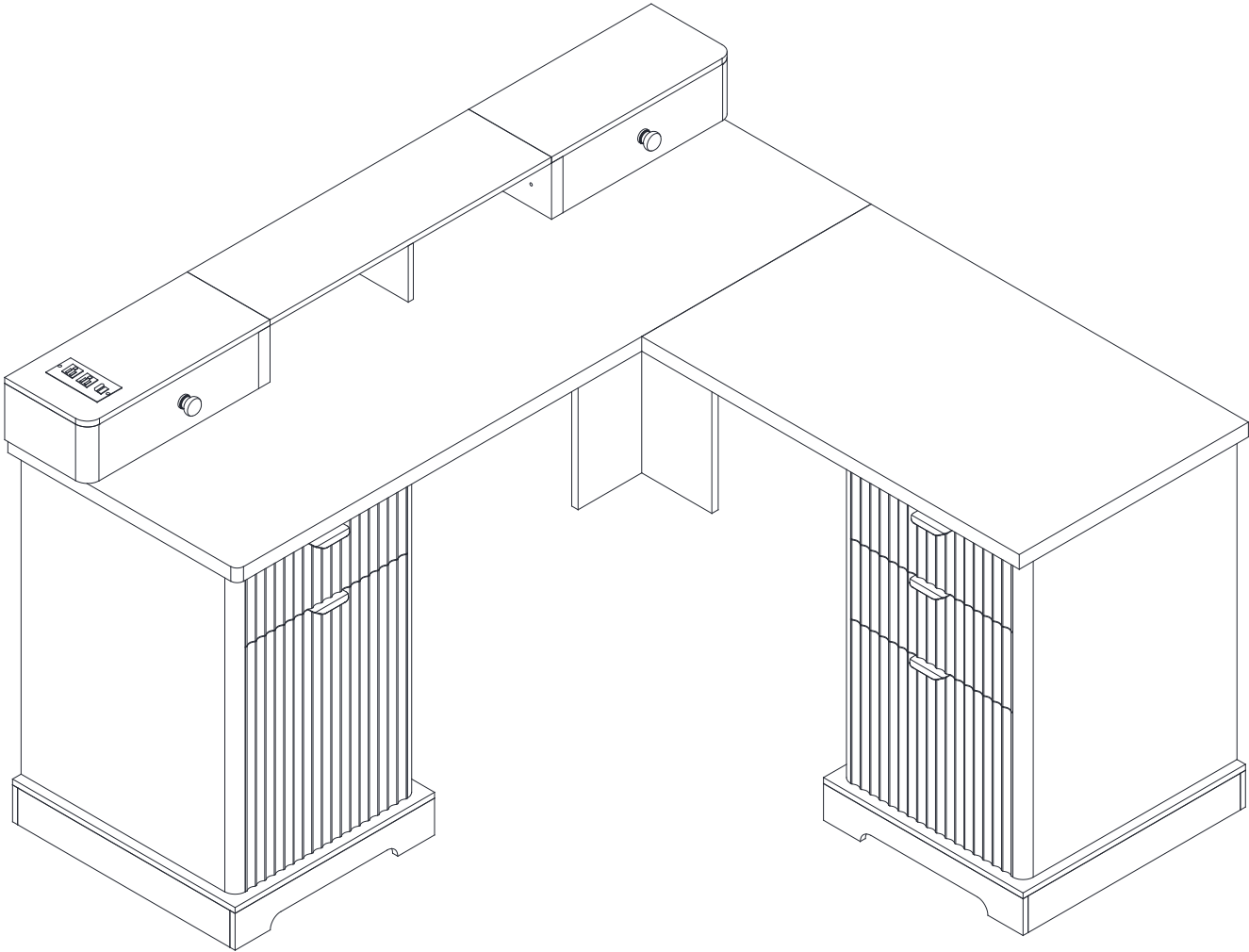

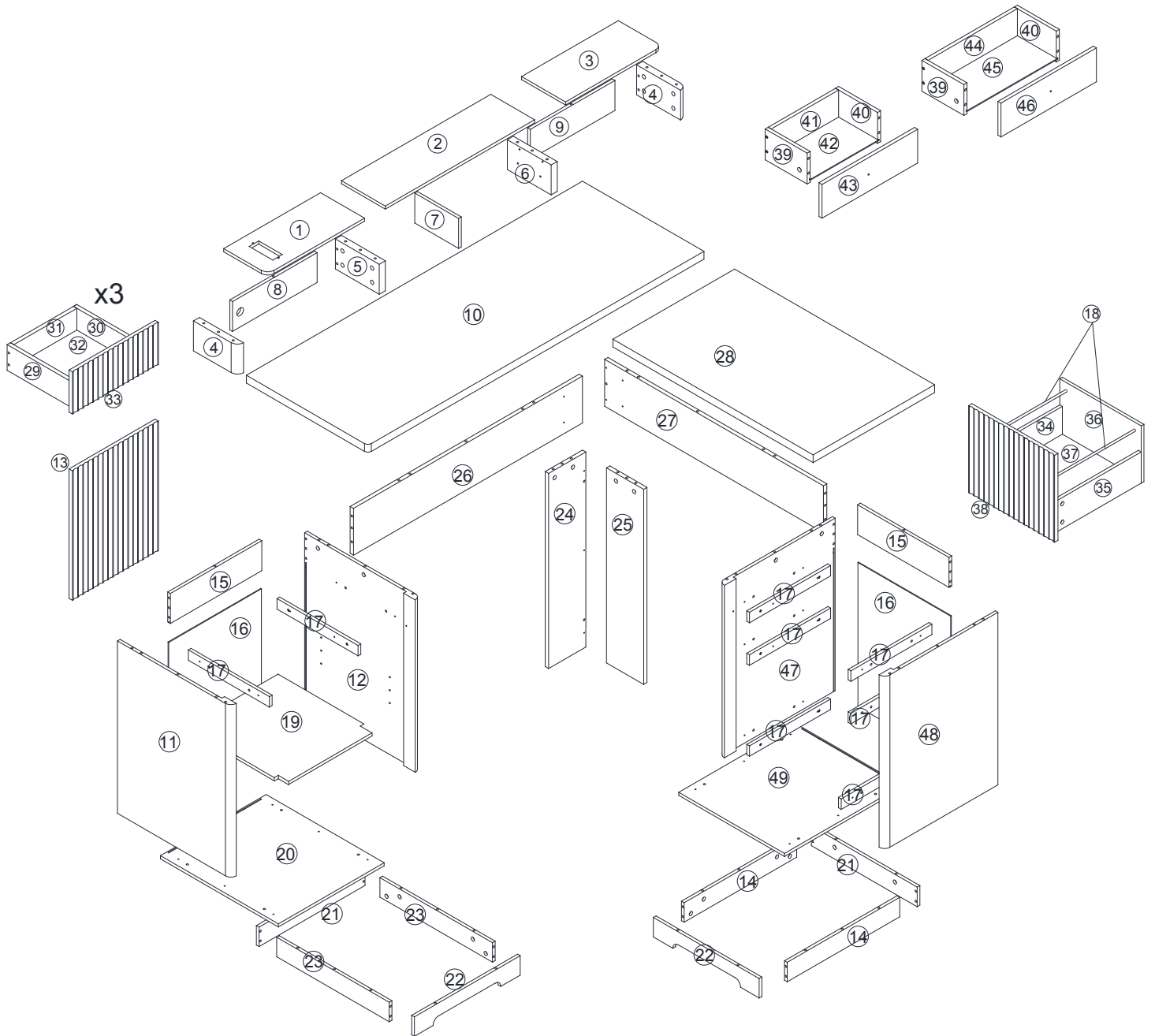











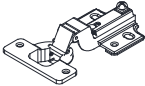

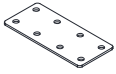
# ASSEMBLY INSTRUCTION

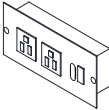

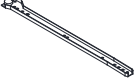
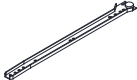
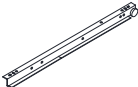
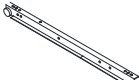

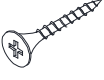
## Hardware List

 A x 97+2	 B x 97+2	 6x30 C x 75+2	 3.5x12 D x 58+2	 4x40 E x 41+2	 F x 2	 G x 2
 4x12 H x 22+2	 I x 1	 J x 16	 K x 5	 L x 1	 6x25 M x 4	 4x16 N x 2
 CL x 4	 CR x 4	 DL x 4	 DR x 4	 O x 4	 P x 4	 4x25 Q x 16+2
 6x20 R x 16+2	 S x 2					

ASSEMBLY TOOLS REQUIRED(NOT INCLUDED)  
OUTILS DE MONTAGE NÉCESSAIRES (NON INCLUS)

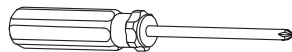

# STEP 1

A		12
---	---	----

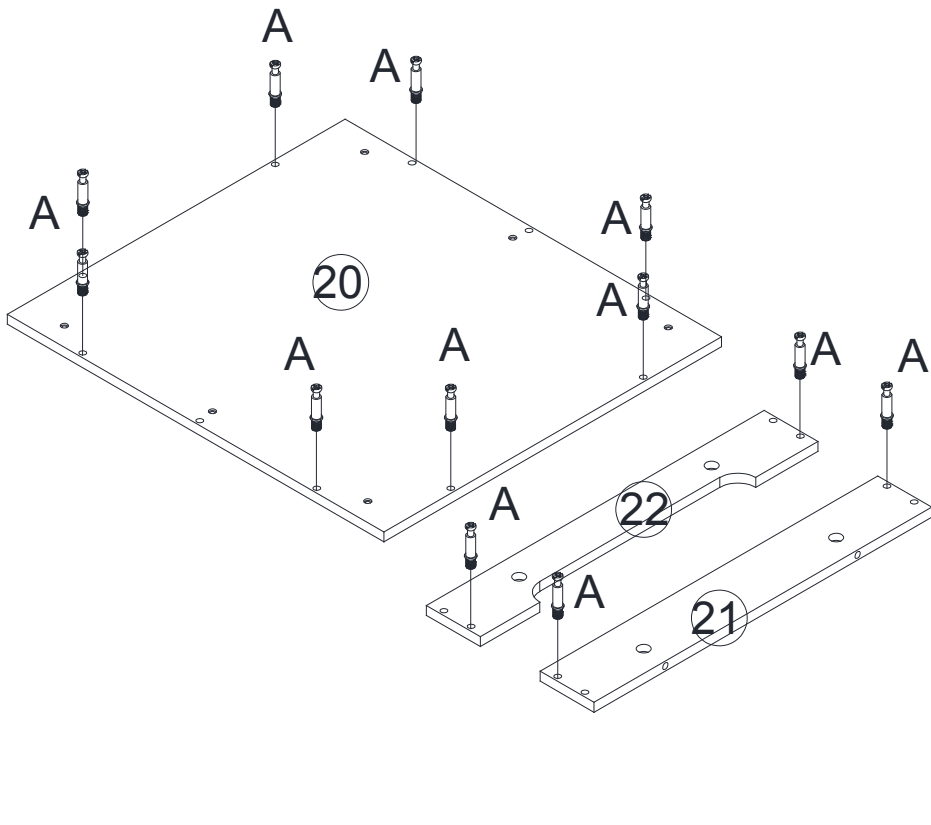

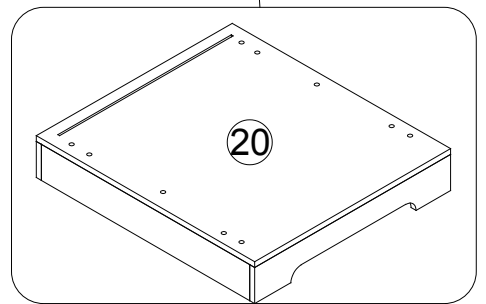
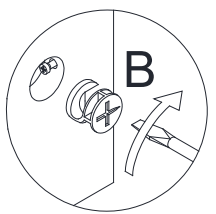
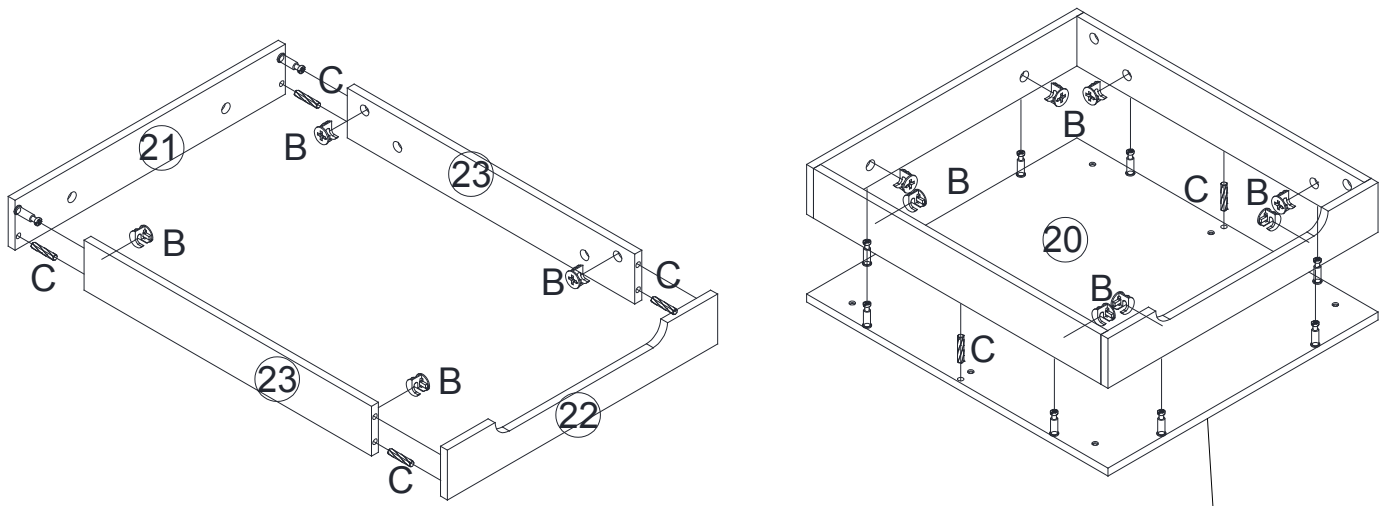

# STEP 2

B		12
C		6





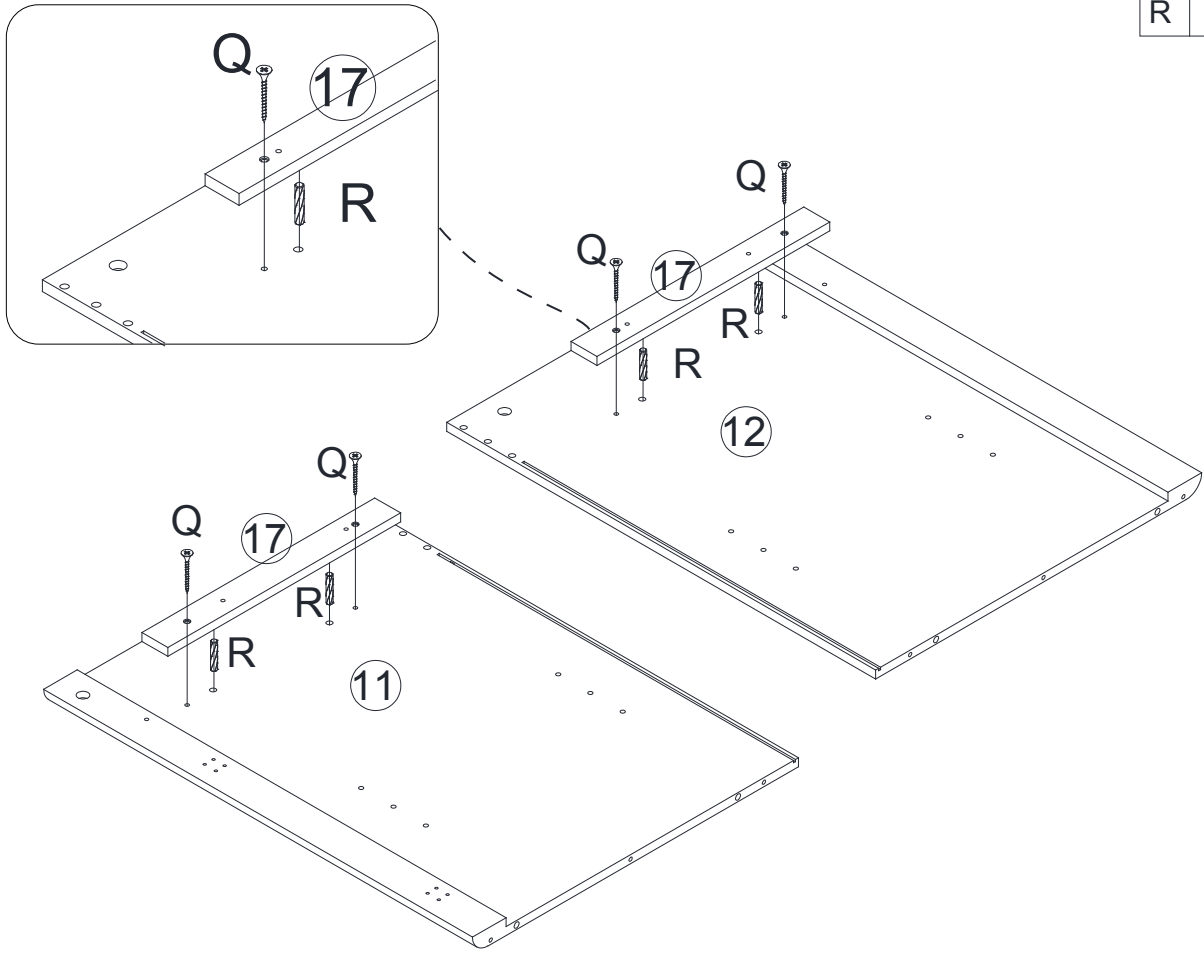

### STEP 3

Q		4
R		4



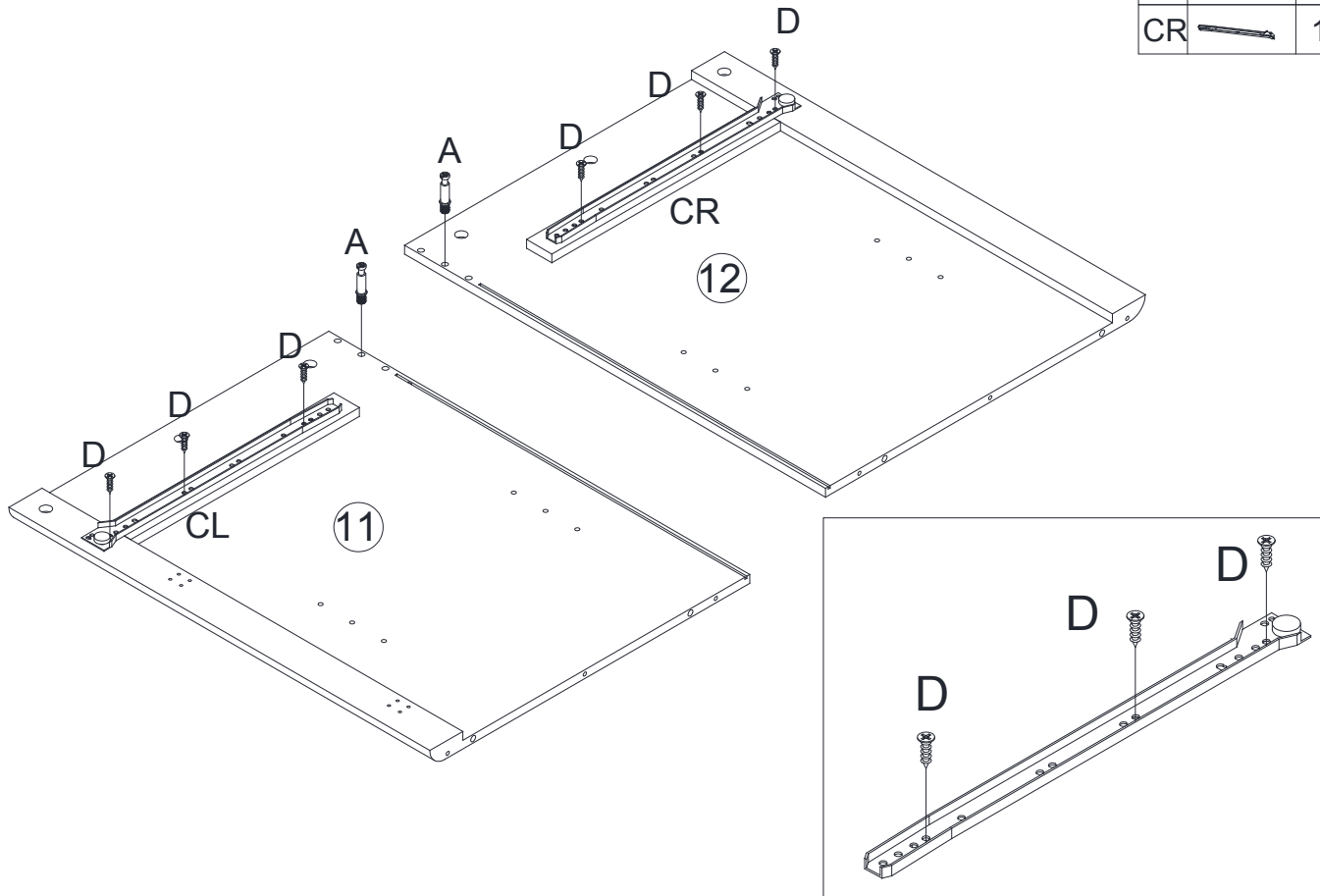

### STEP 4

A		2
D		6
CL		1
CR		1



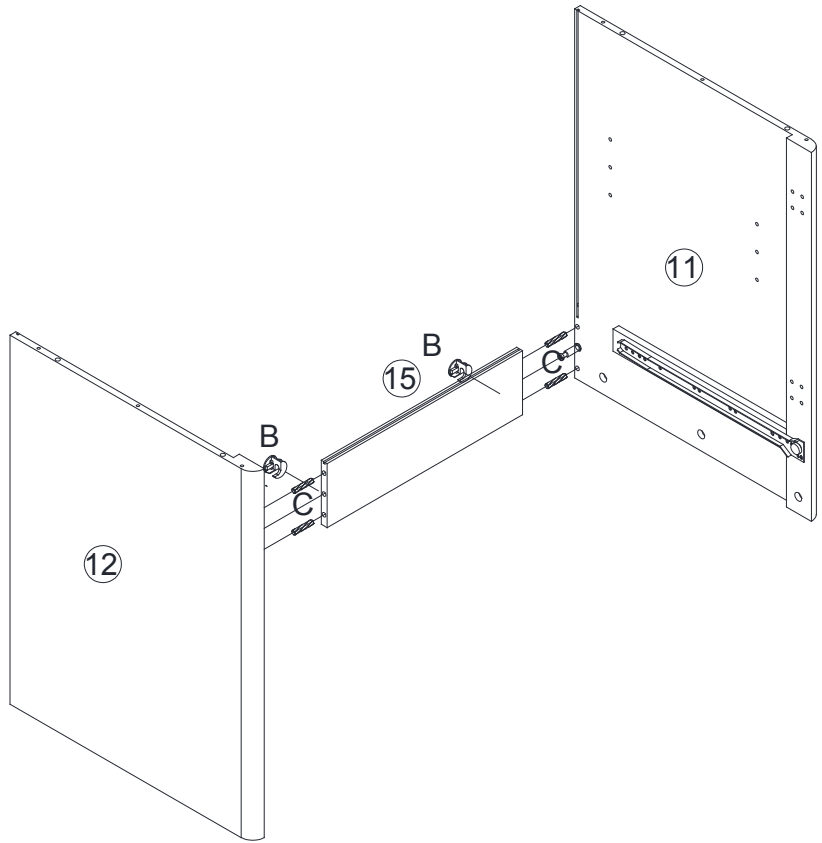

# STEP 5

B		2
C		4



# STEP 6

E		6
C		4

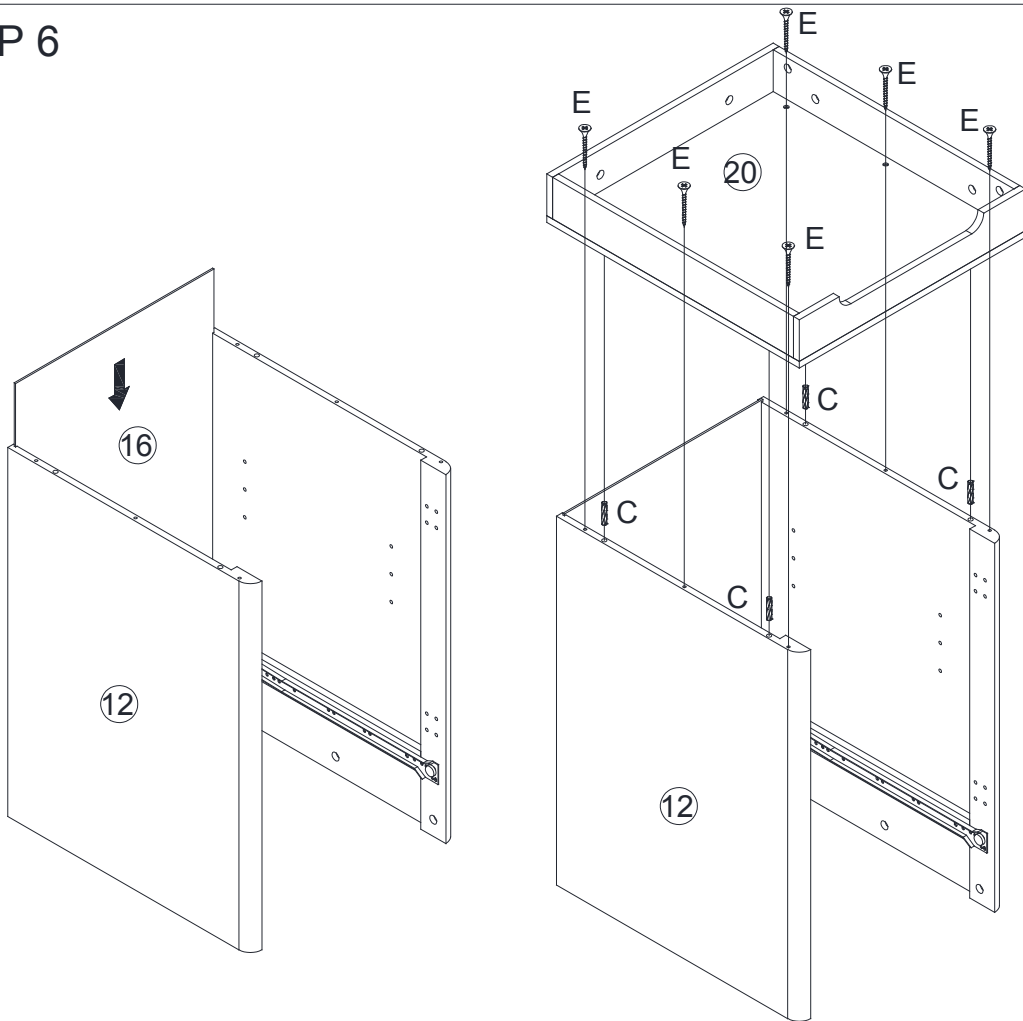

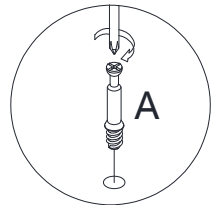
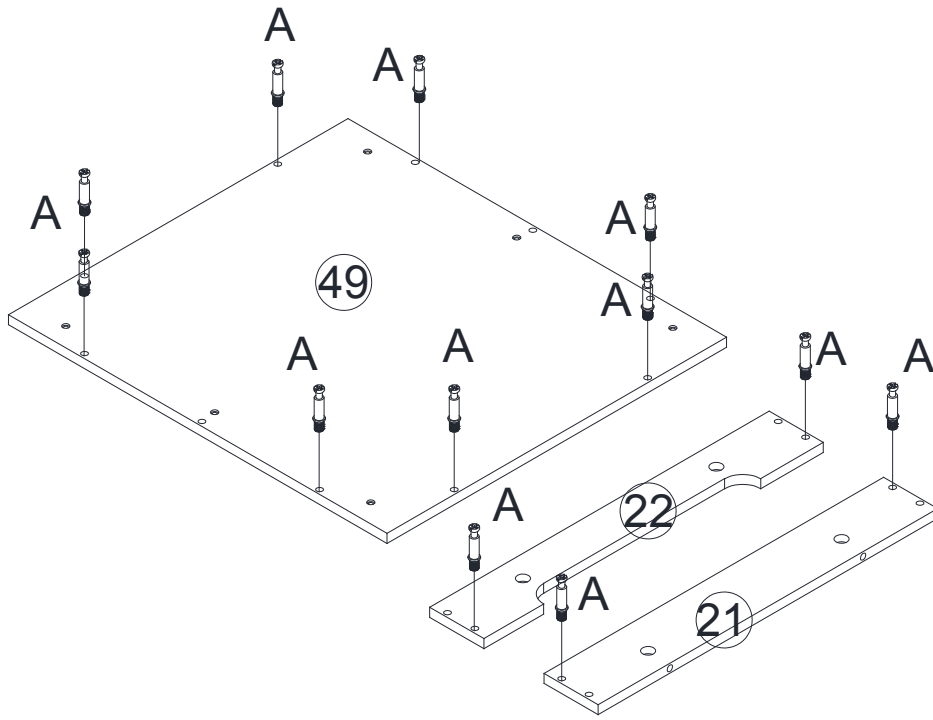

# STEP 7

A		12
---	---	----



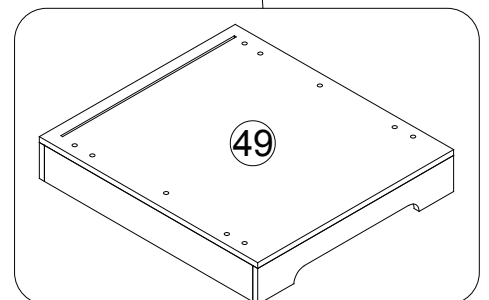
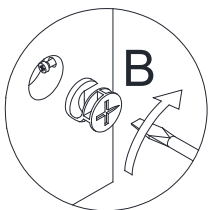
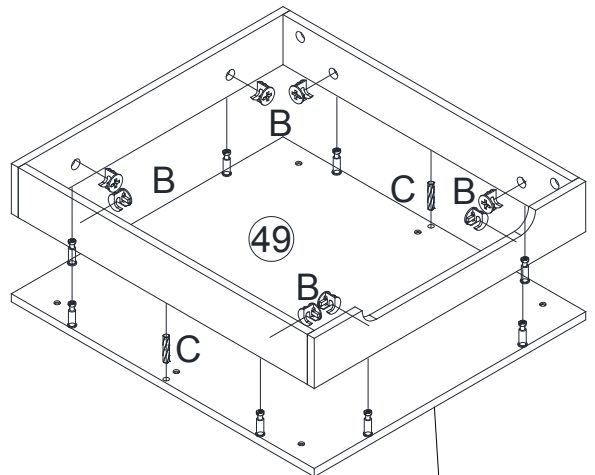
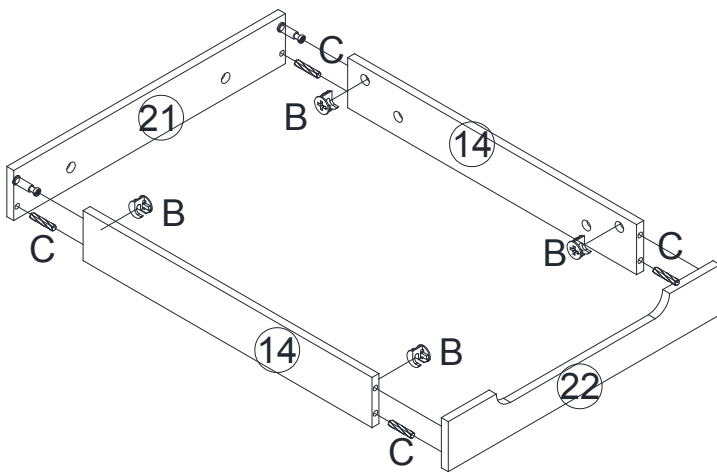

# STEP 8

B		12
C		6





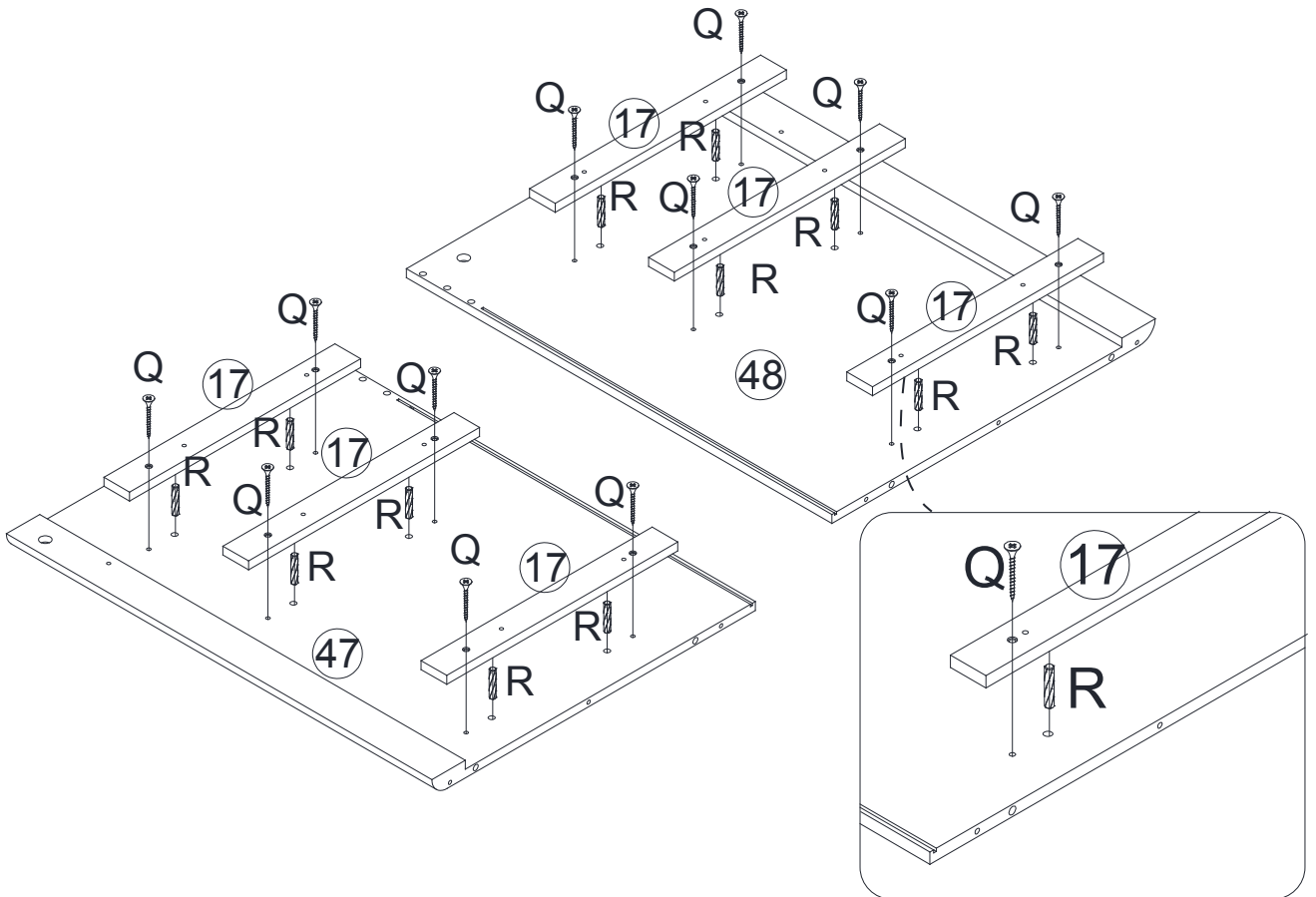

# STEP 9

Q		12
R		12



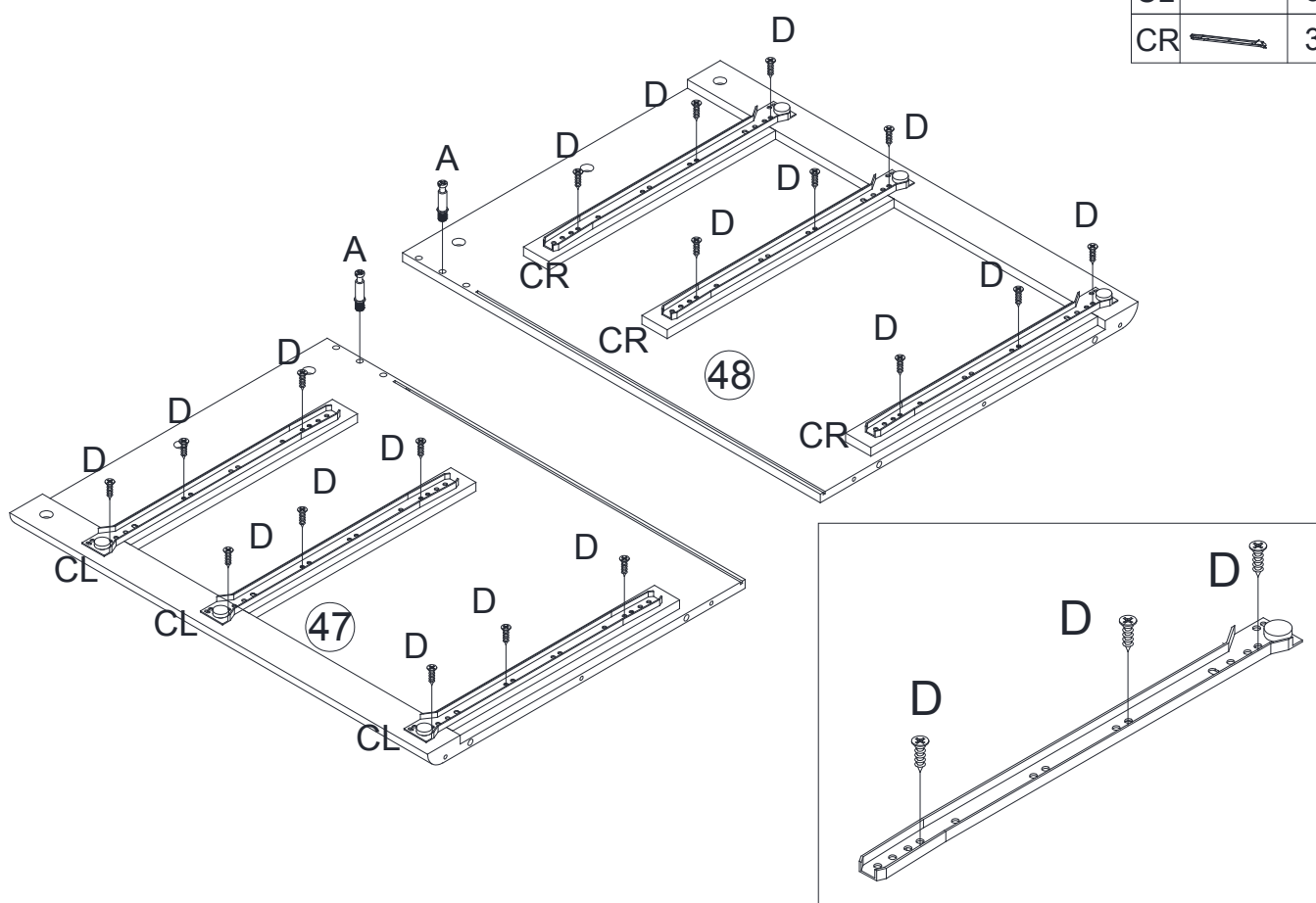

# STEP 10

A		2
D		18
CL		3
CR		3



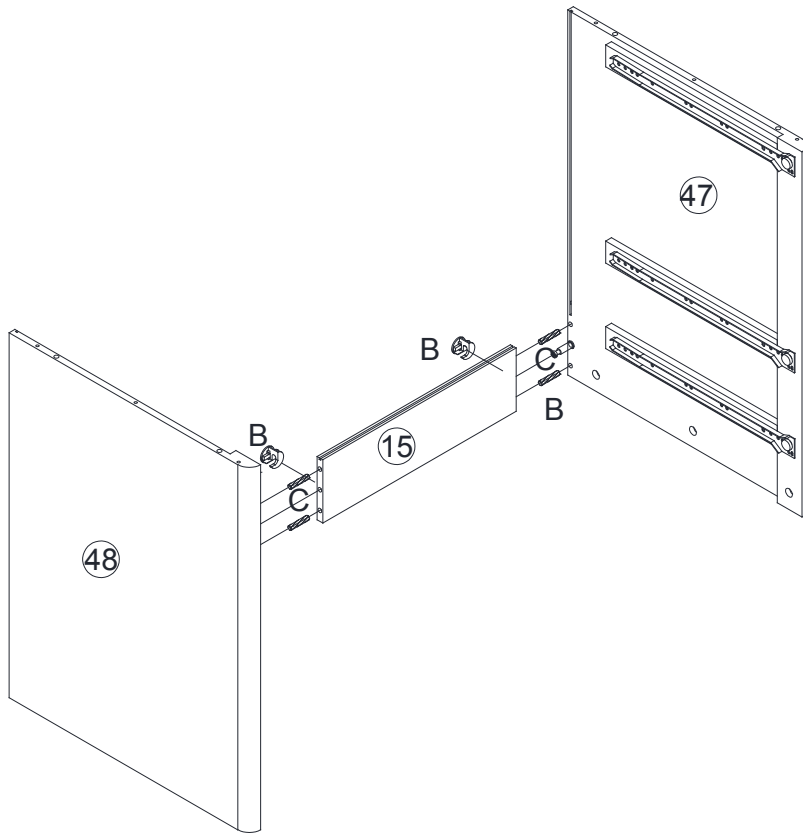

# STEP 11

B		2
C		4



# STEP 12

E		6
C		4

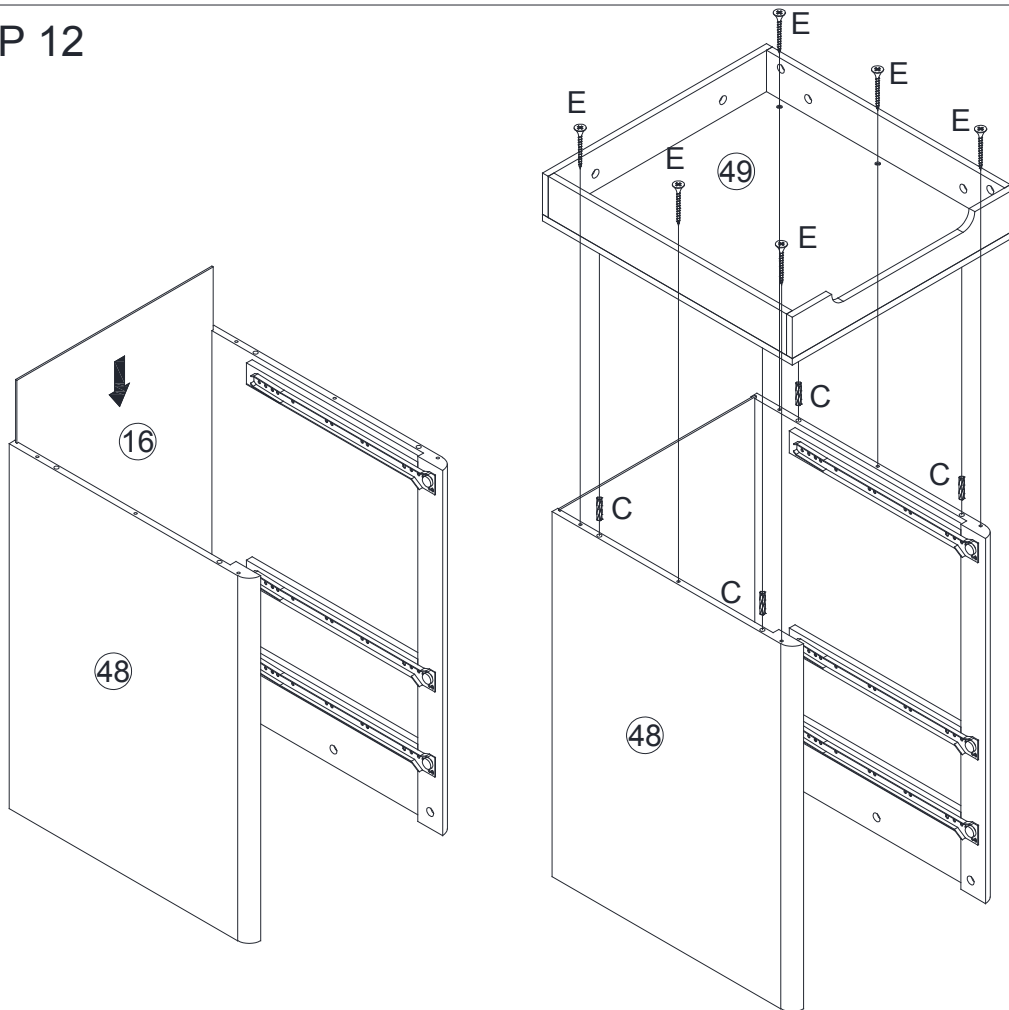

# STEP 13

A		4
---	---	---

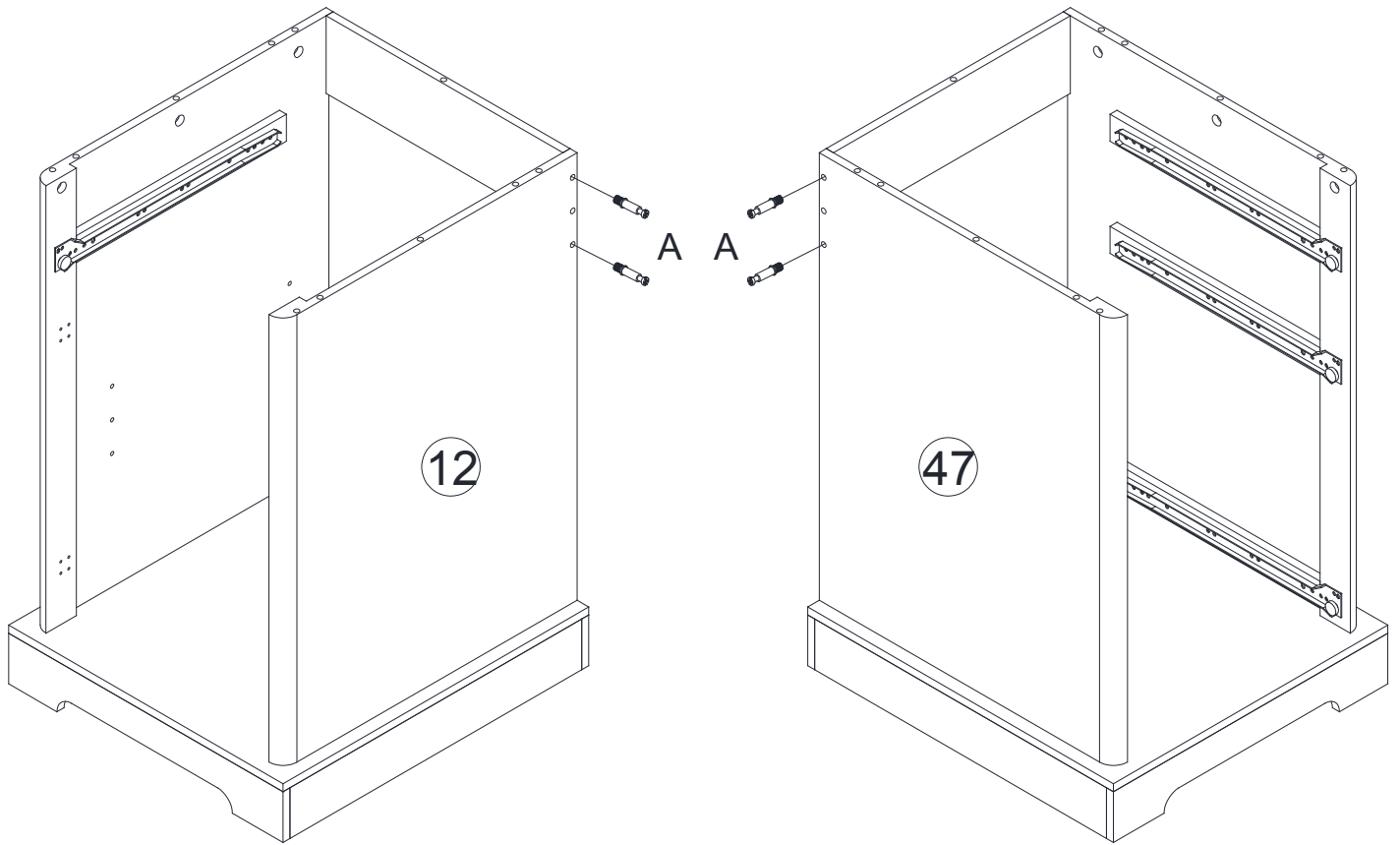

# STEP 14

C		2
E		3
M		2

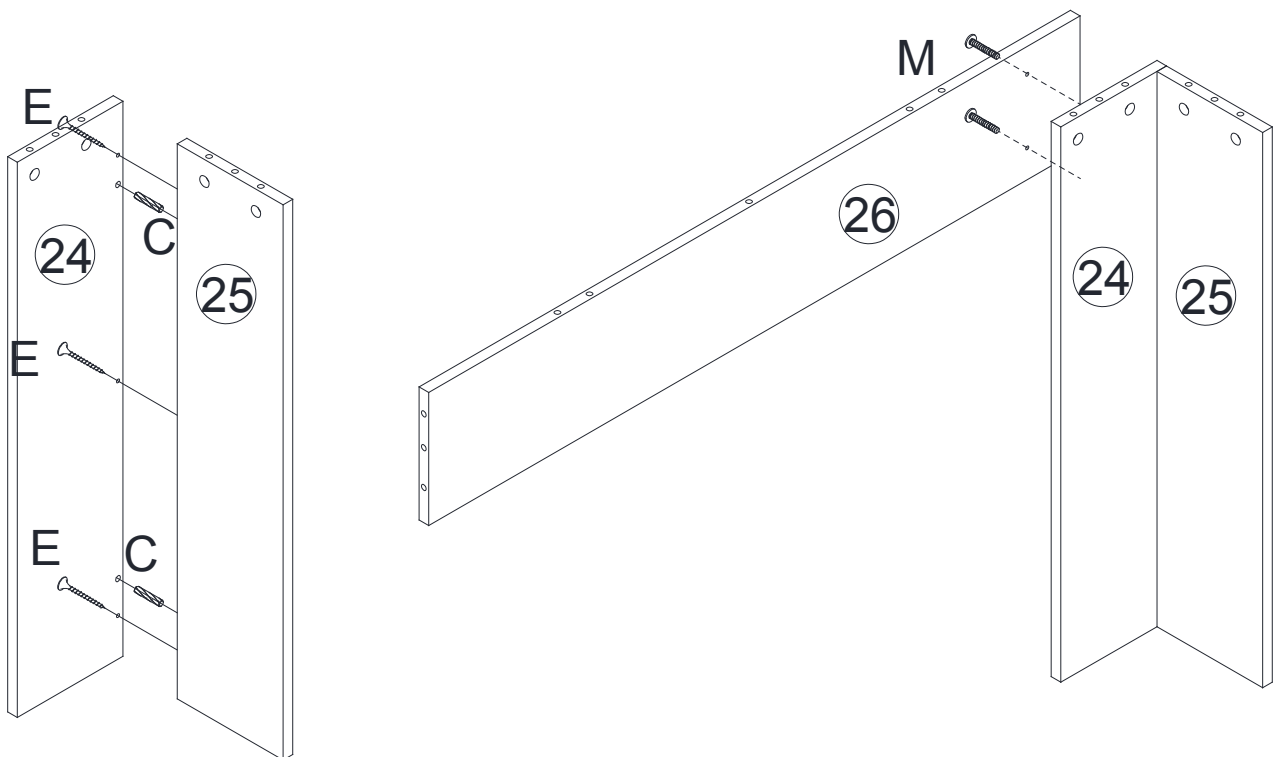

# STEP 15

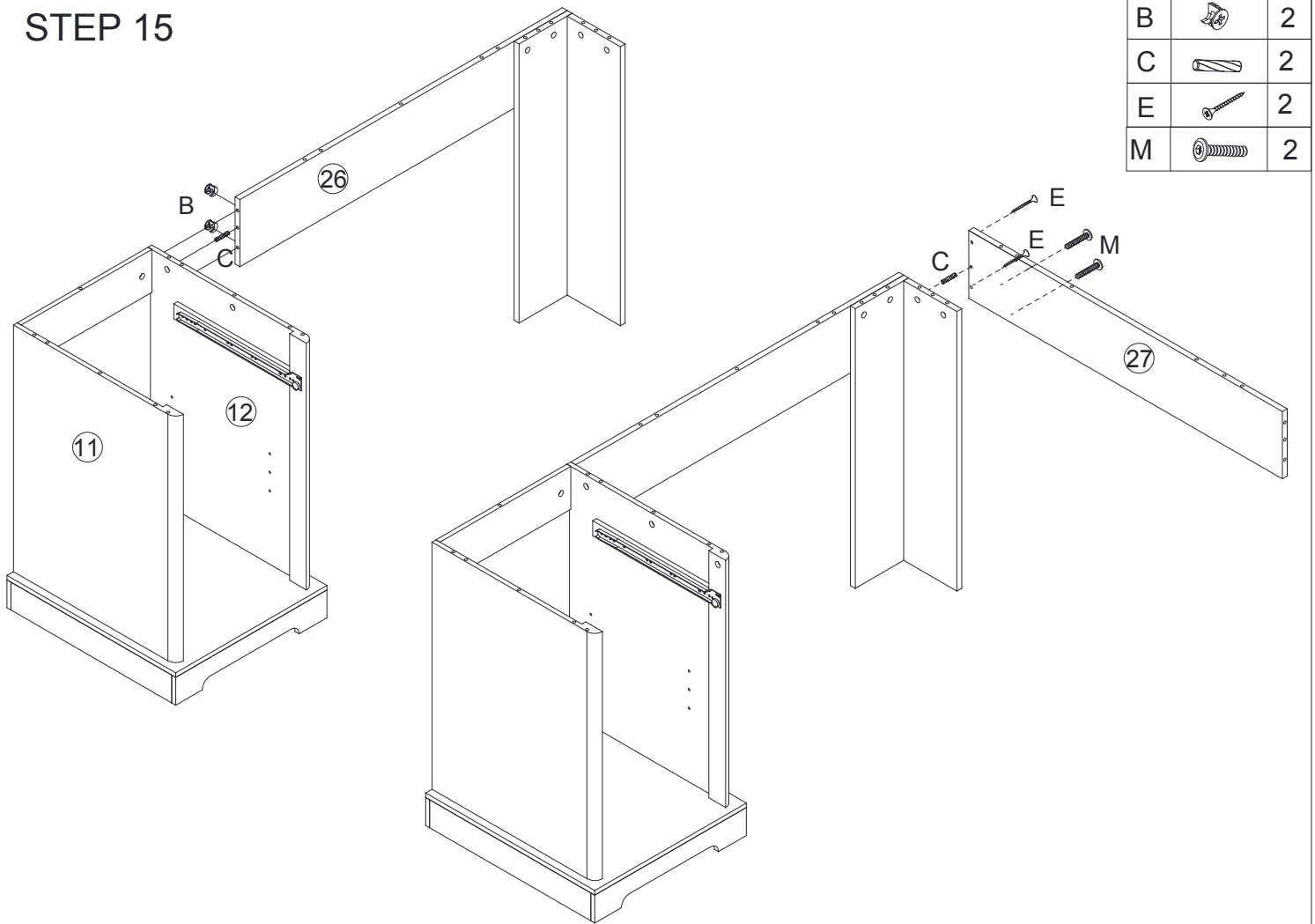

# STEP 16

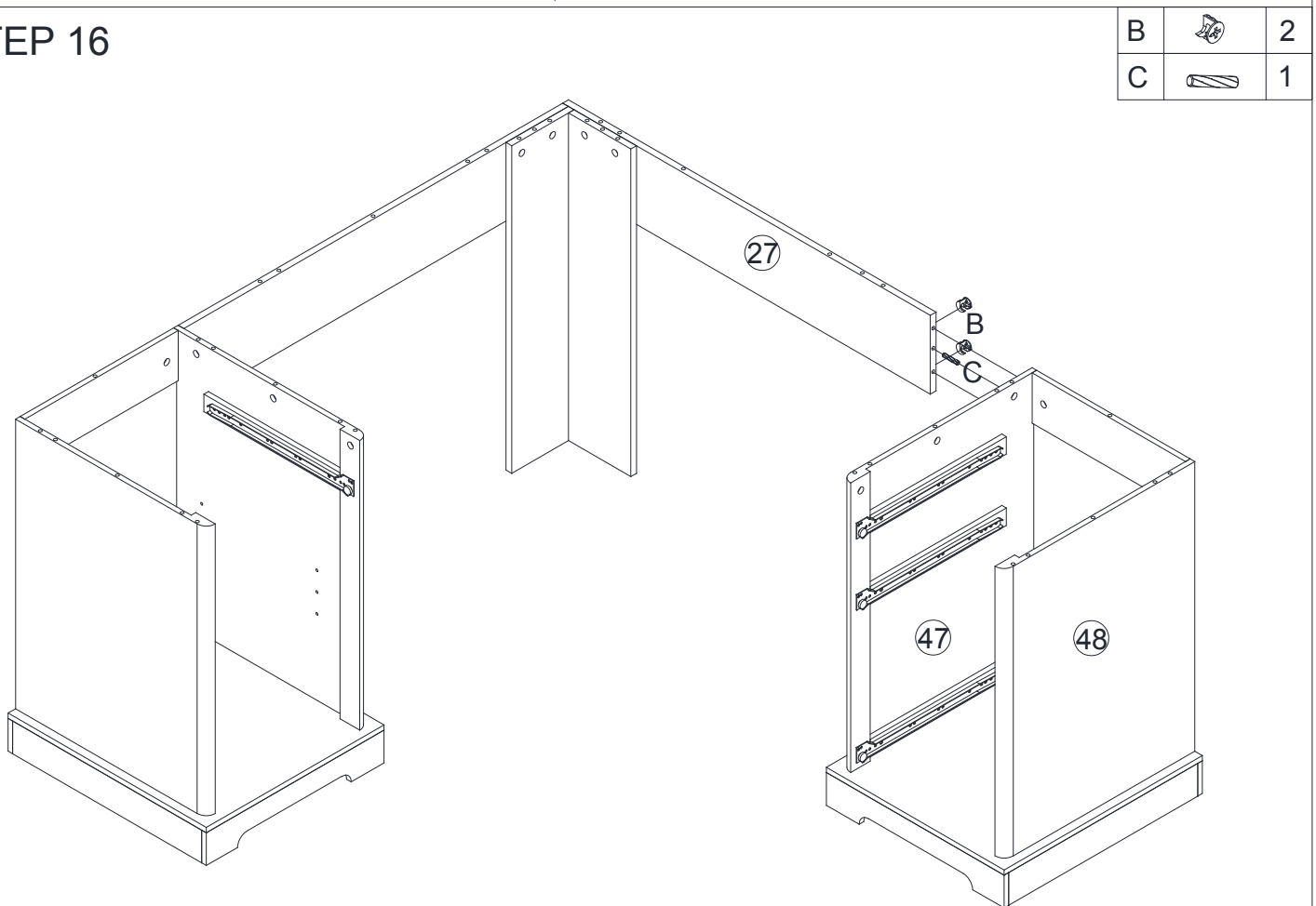

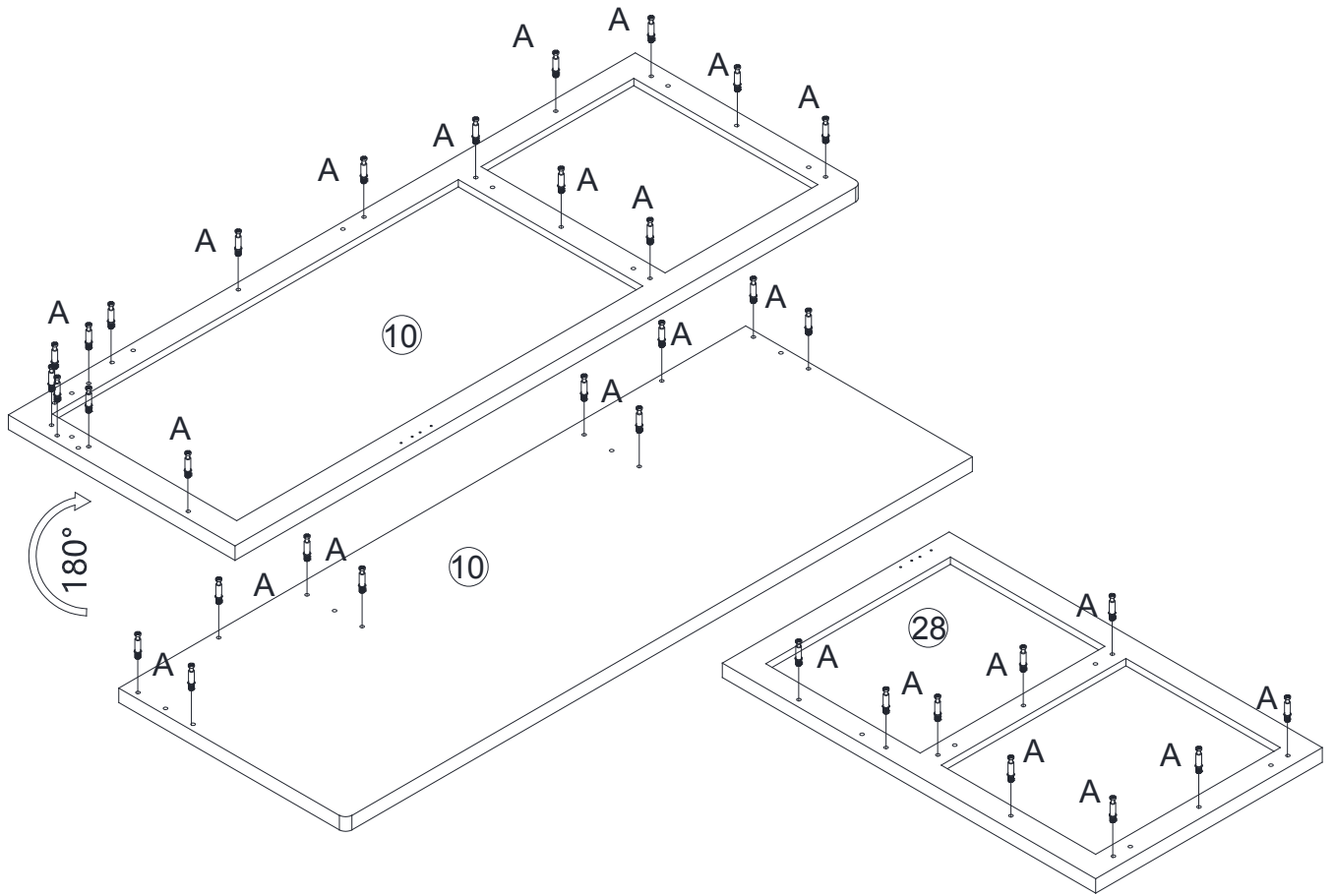

# STEP 17

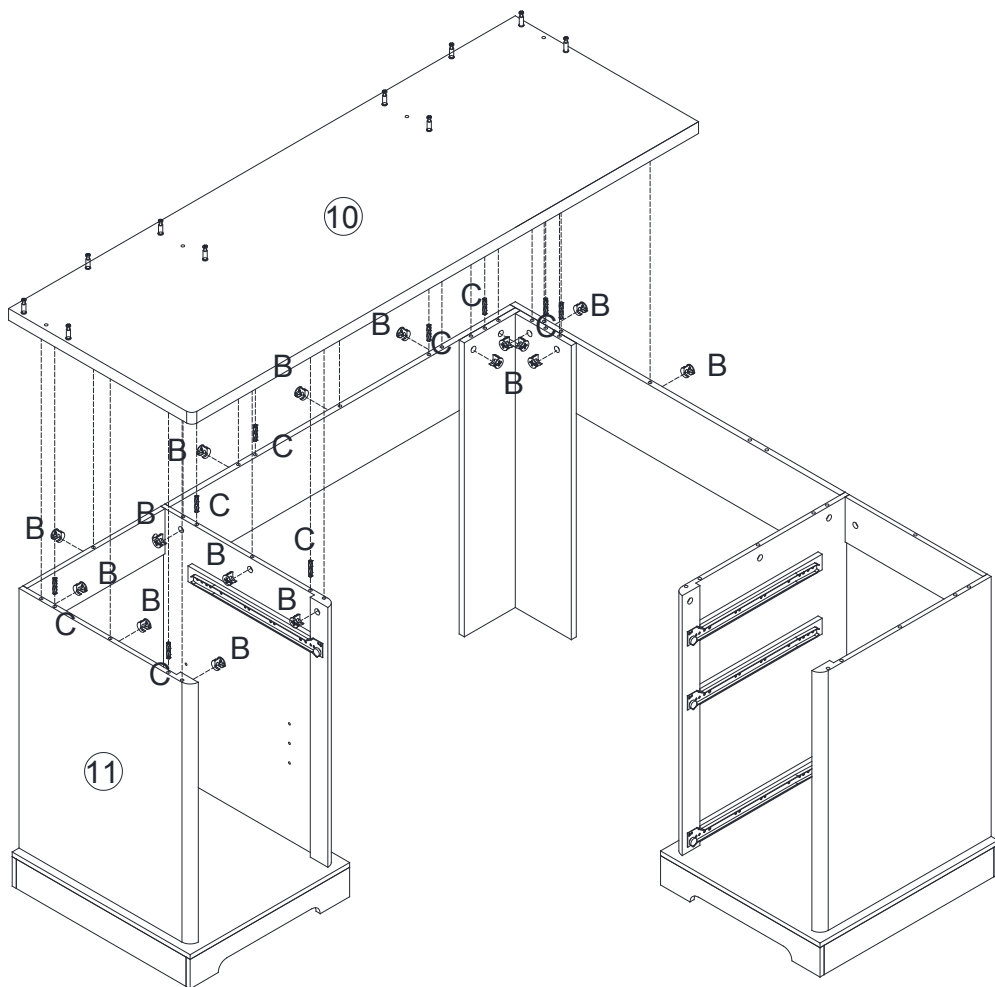

# STEP 18



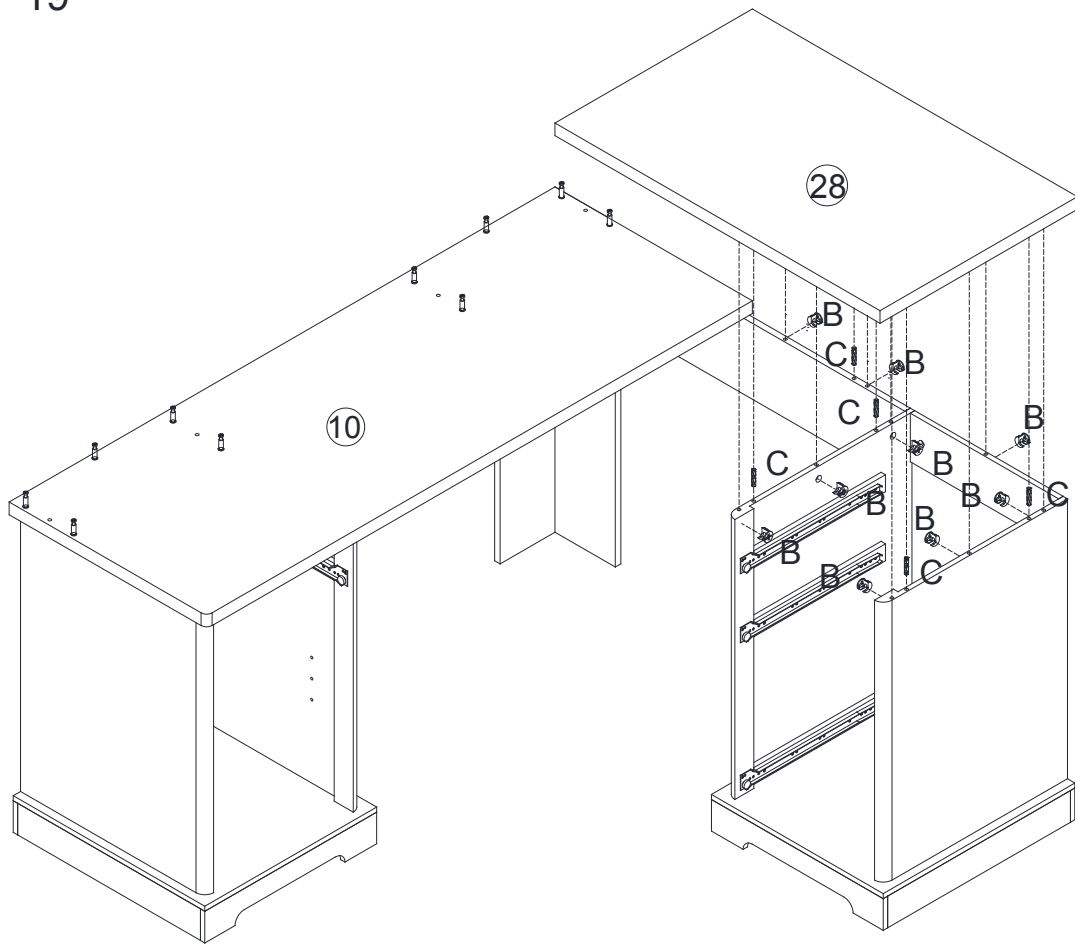

# STEP 19

B		9
C		5



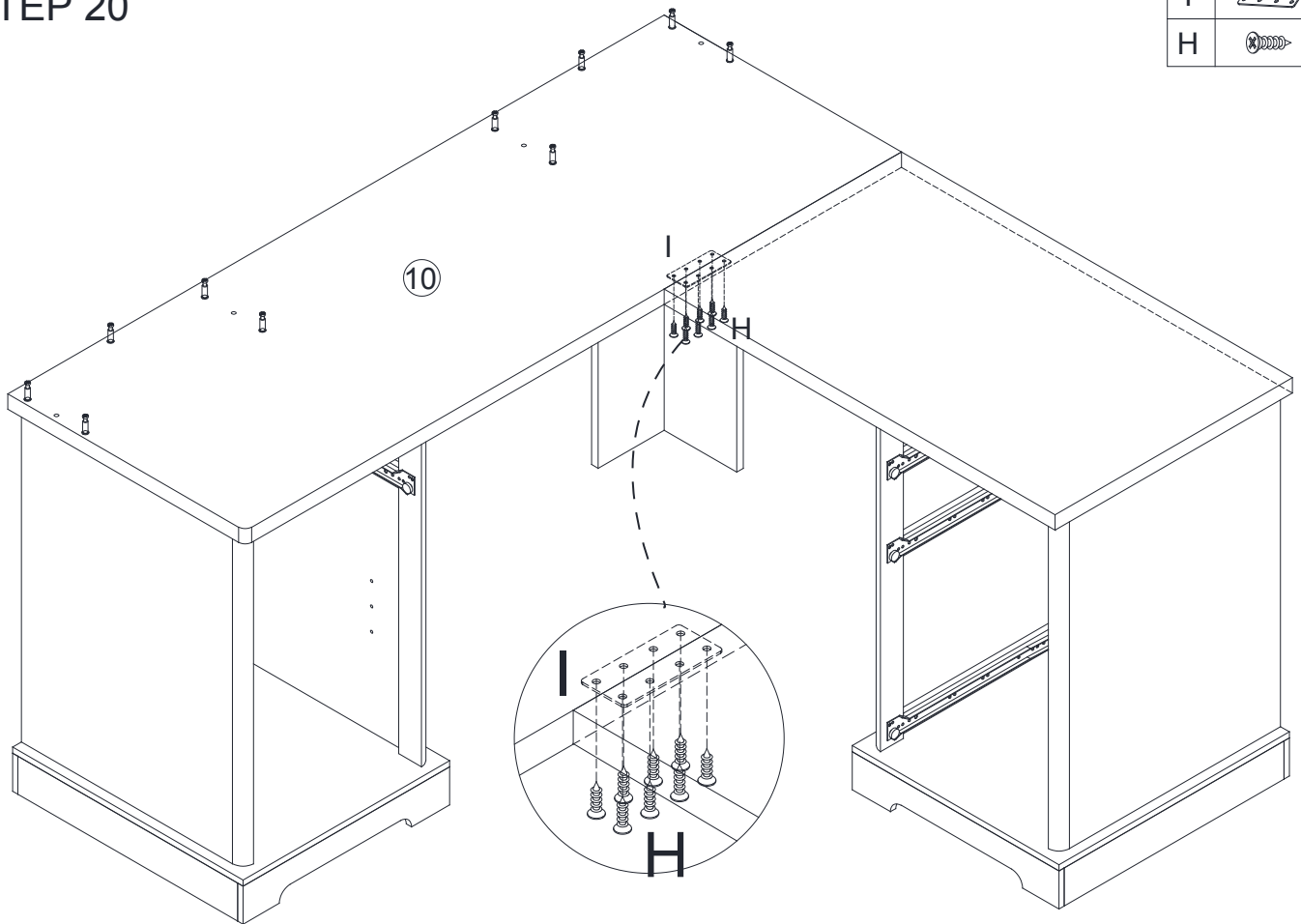

# STEP 20

I		1
H		8



# STEP 21

B		10
C		12

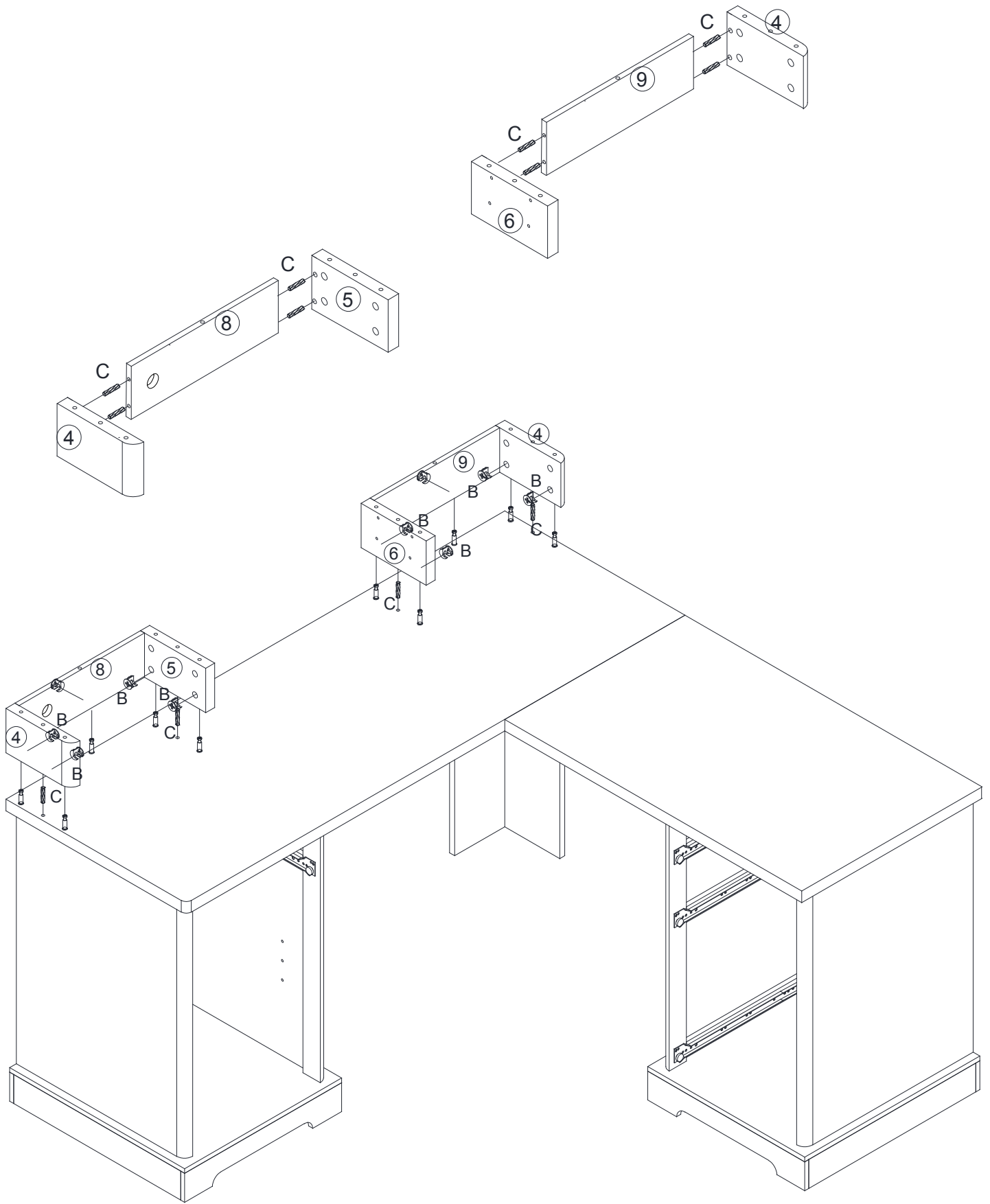

# STEP 22

A		10
---	---	----

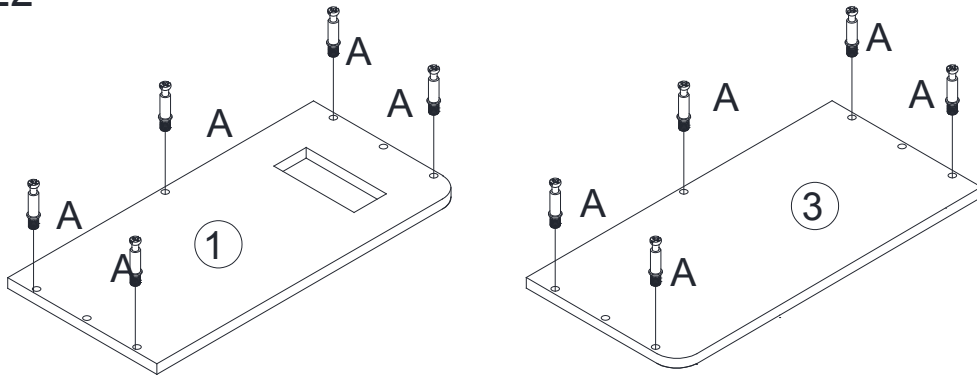

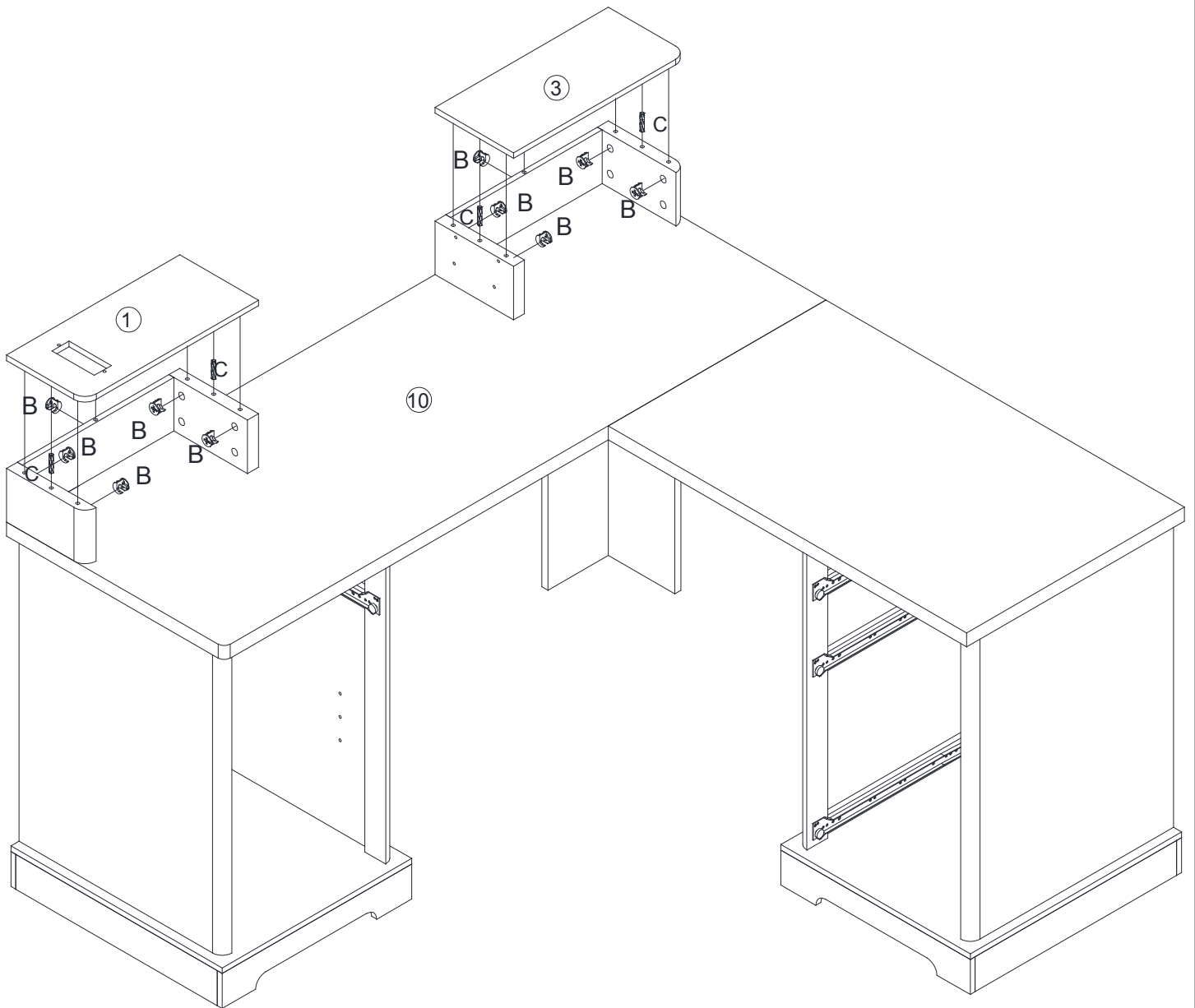

# STEP 23

B		10
C		4



# STEP 24

H		2
L		1

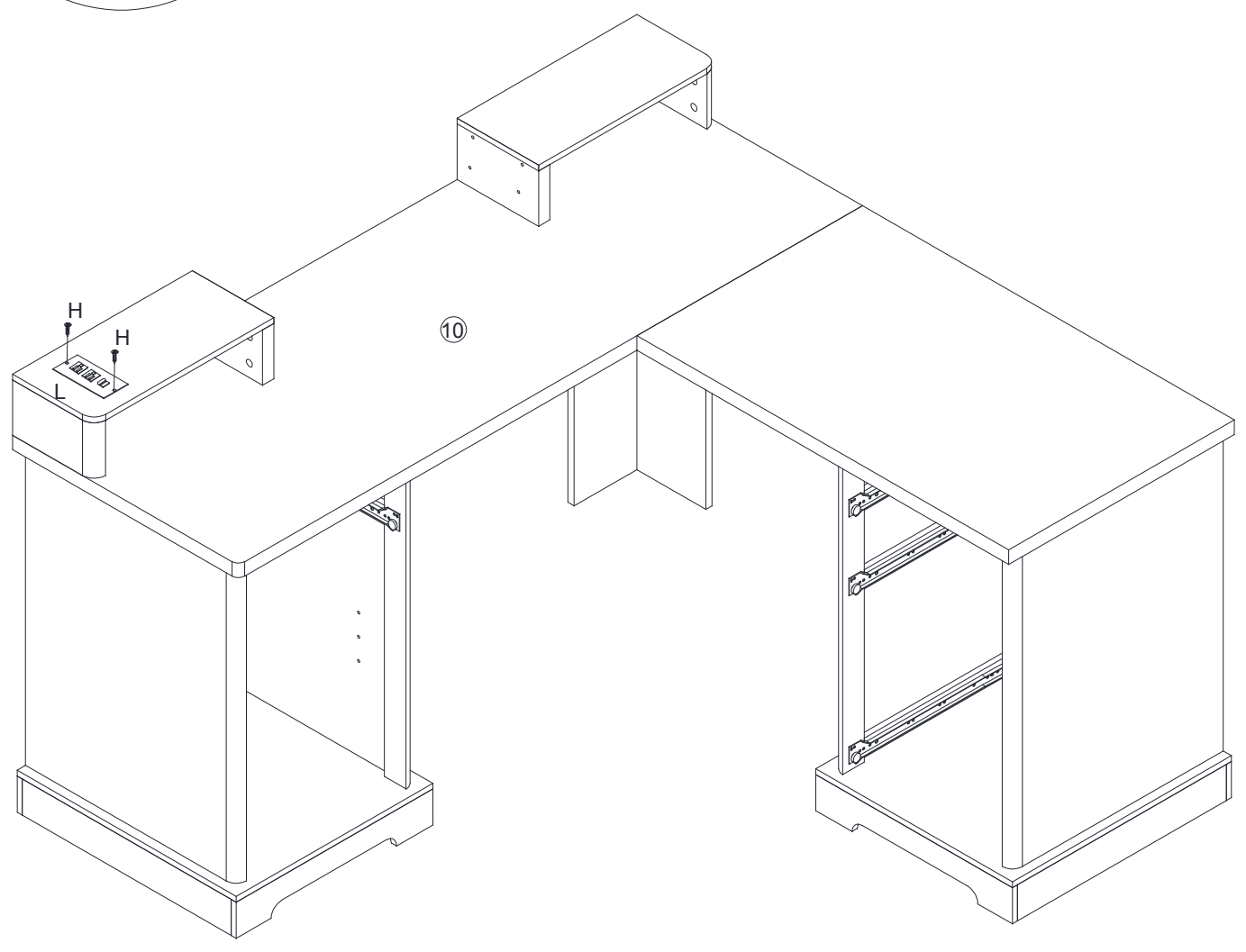
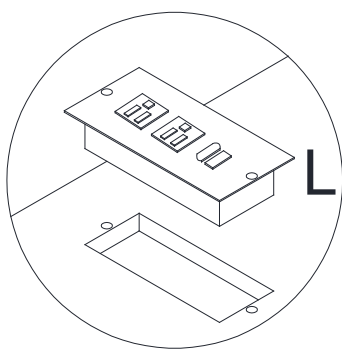

# STEP 25

P



4

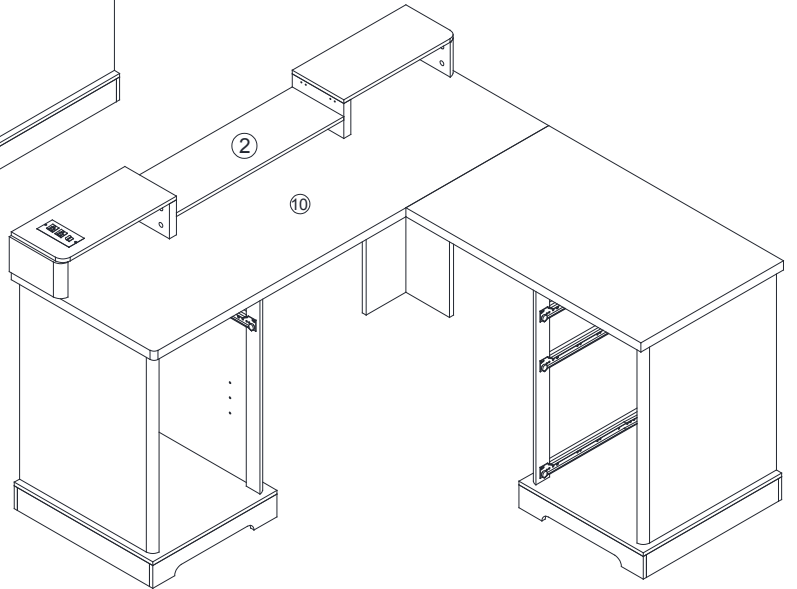
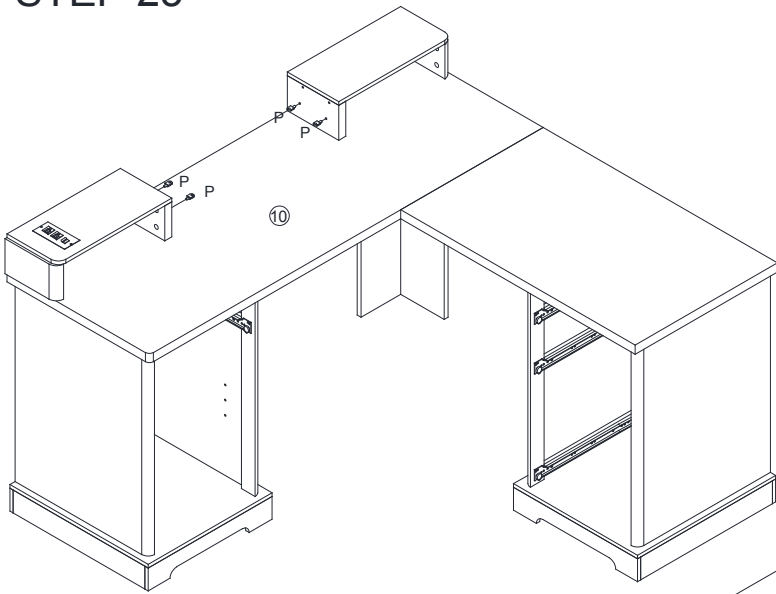

OR

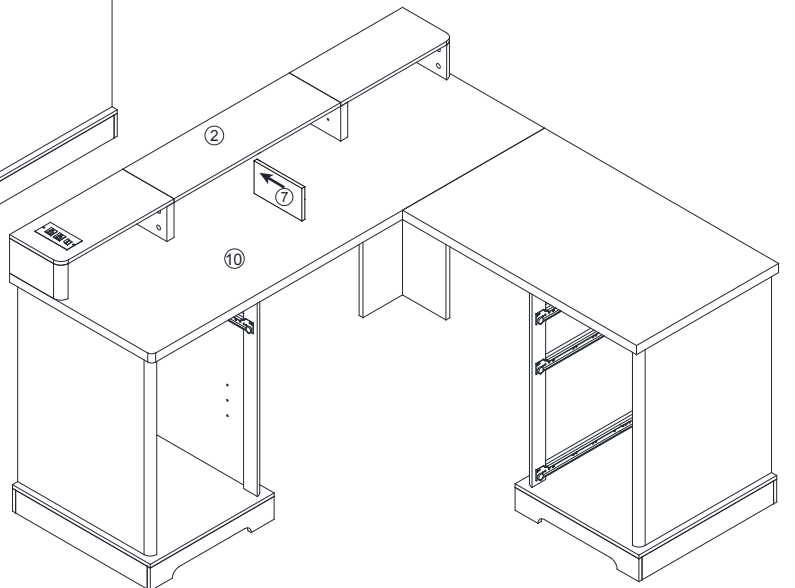
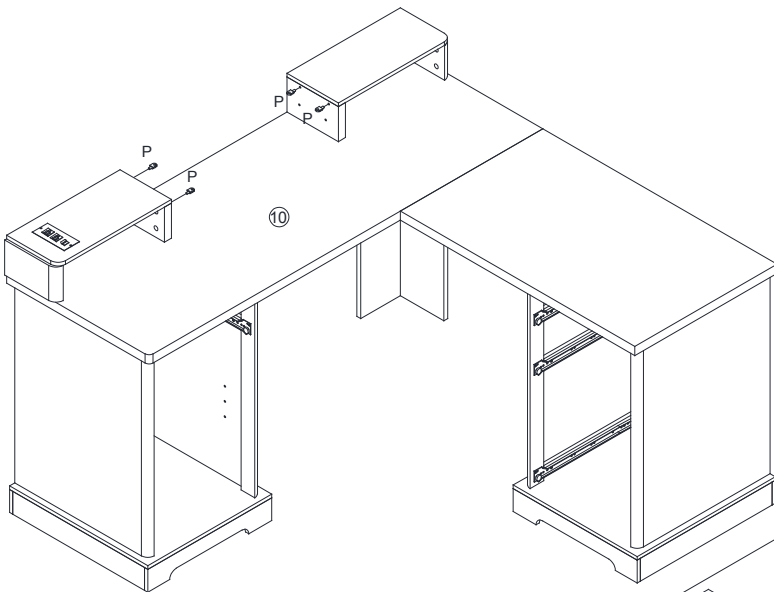

# STEP 26

C		6	A		12
K		3	B		12
			D		24
			E		12
			DL		3
			DR		3

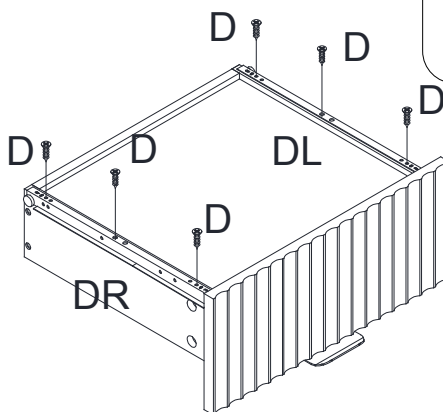
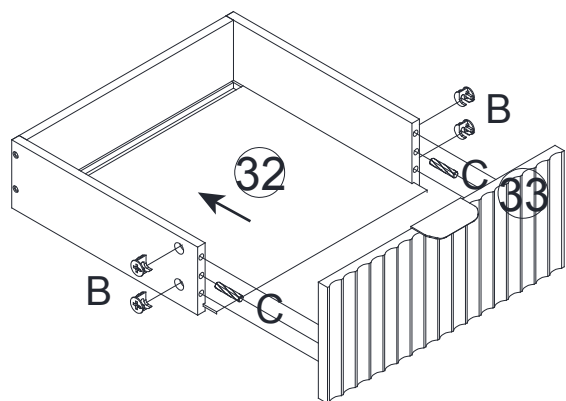
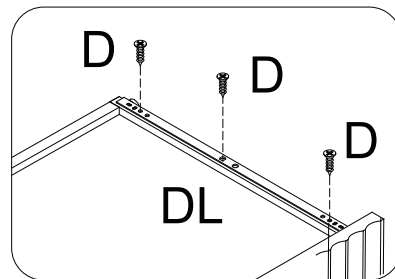
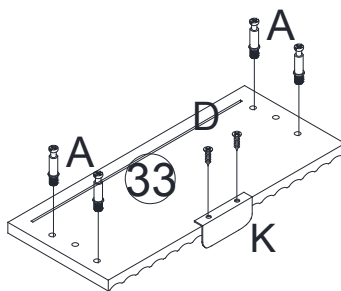
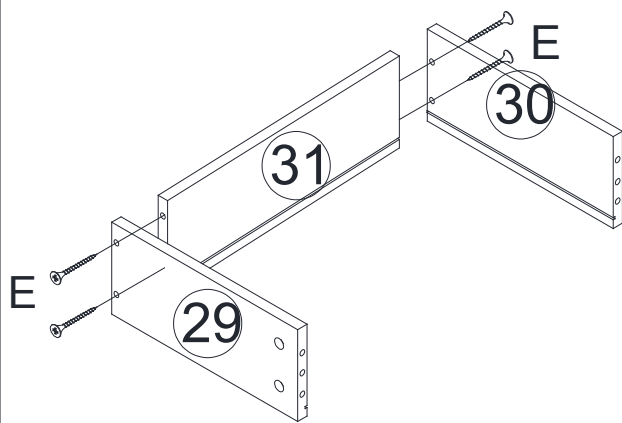



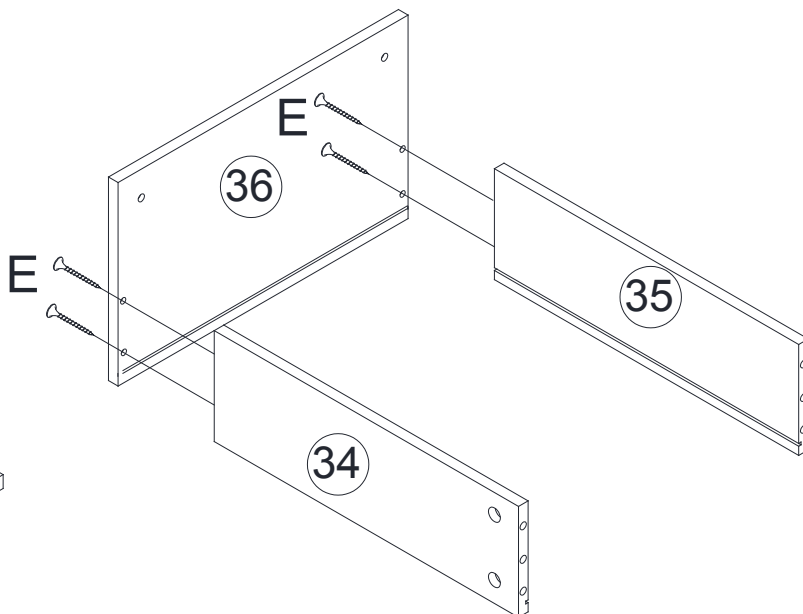
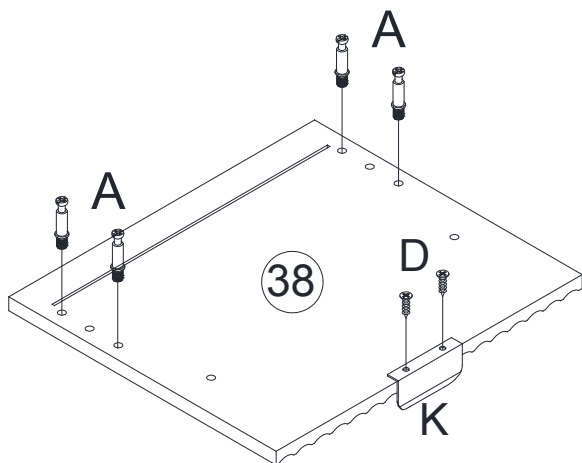

x3

# STEP 27

A		4
E		4
D		2
K		1



# STEP 28

DL		1
DR		1
D		6
B		4
C		2

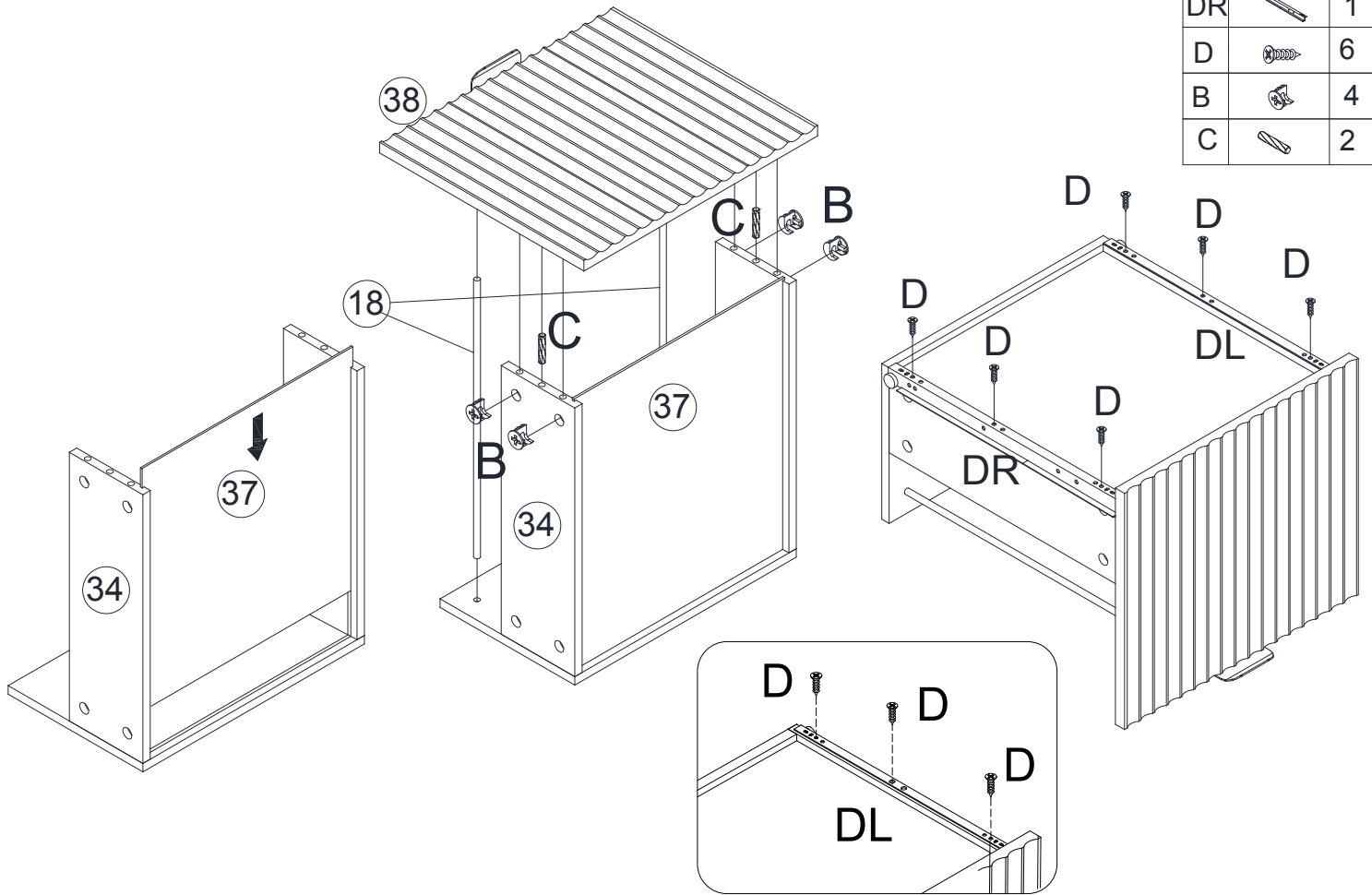

# STEP 29

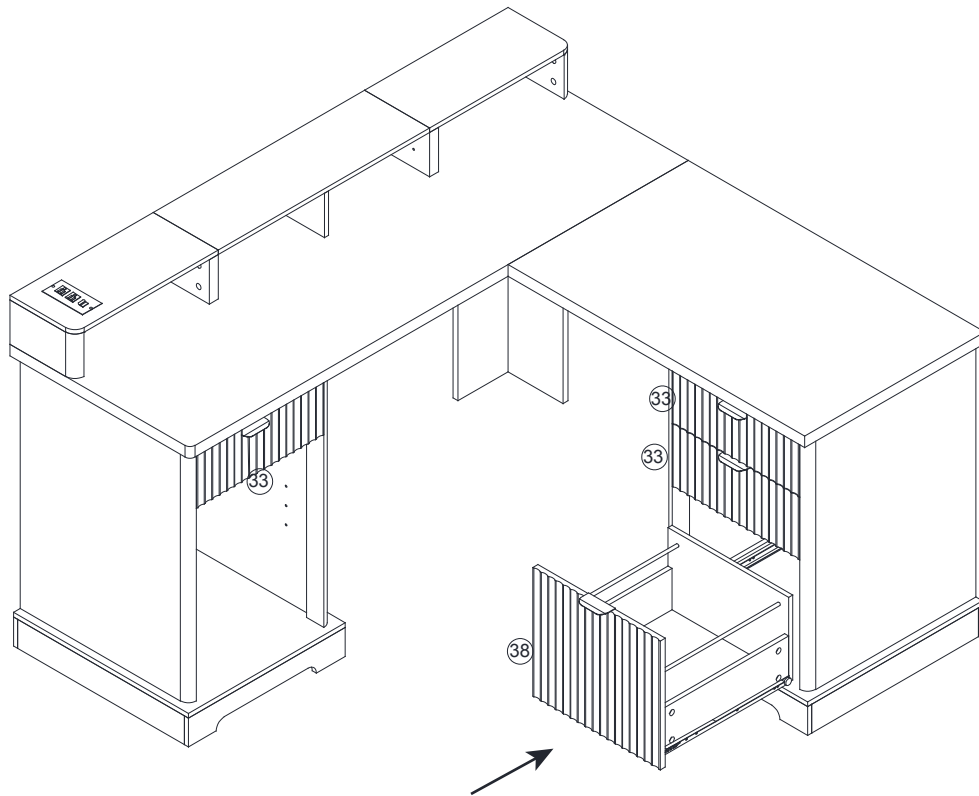



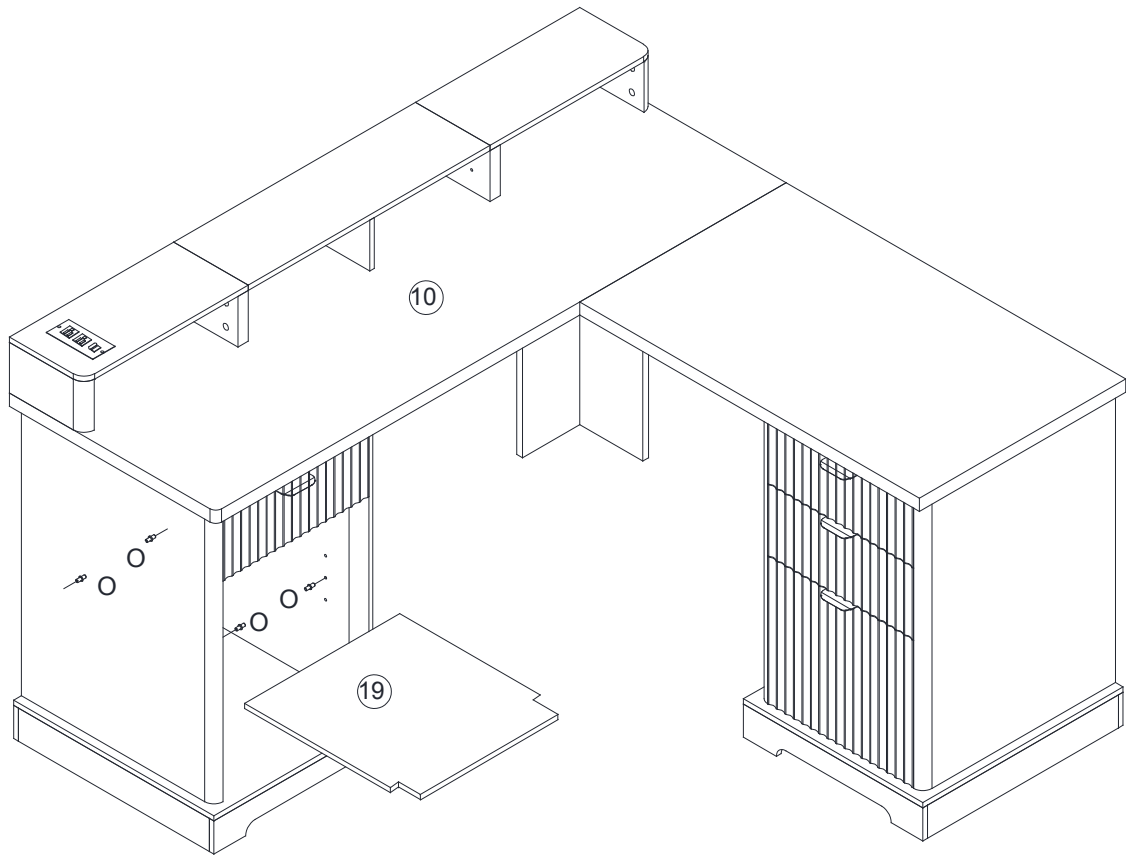

# STEP 30

O  4



# STEP 31

H		4
D		2
F		2
K		1

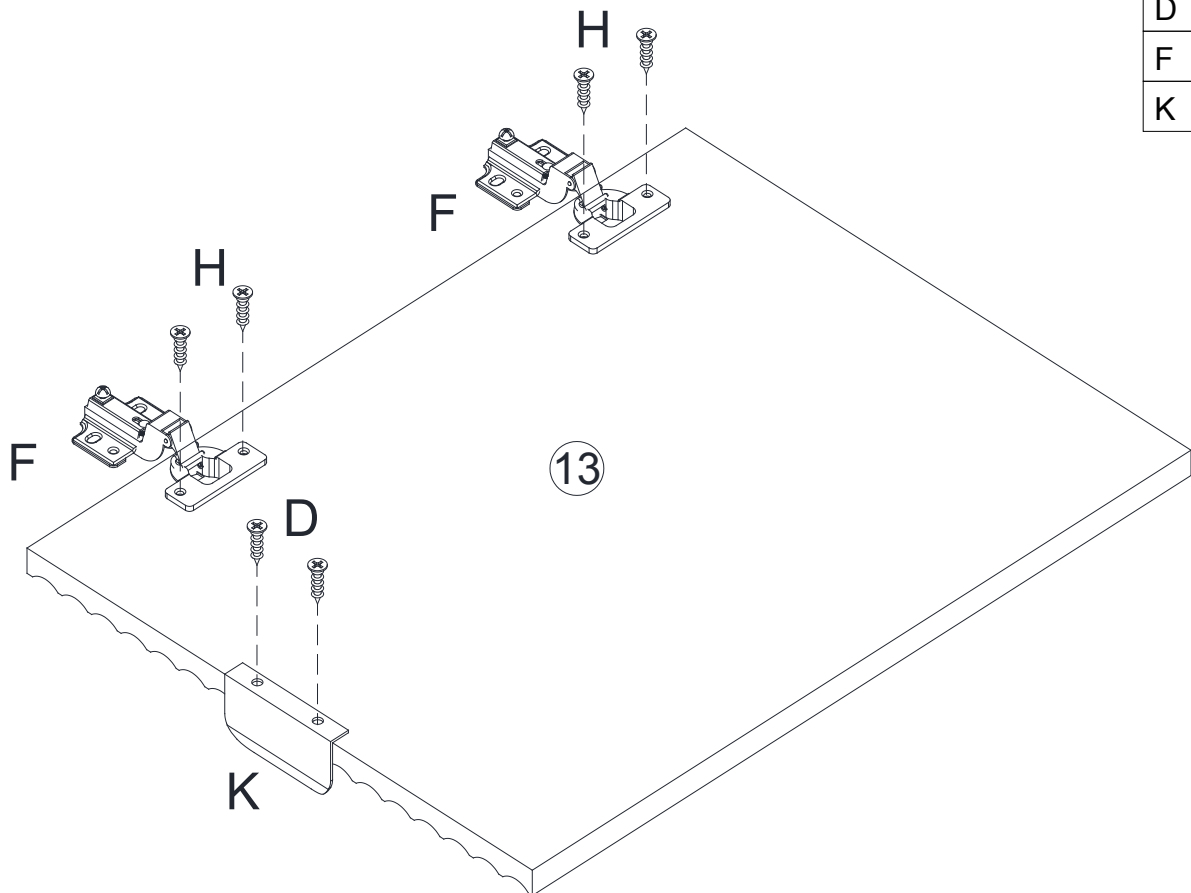





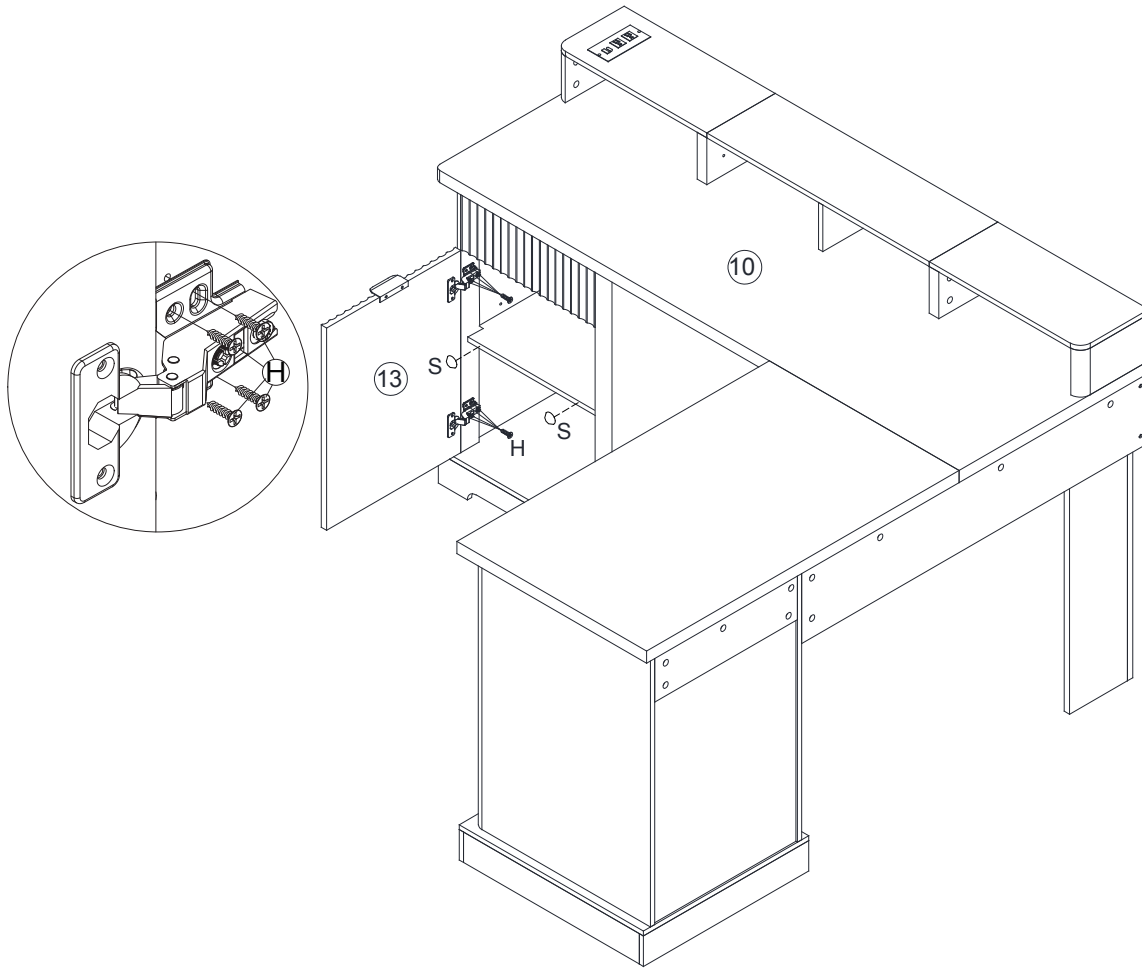

# STEP 32

H		8
S		2







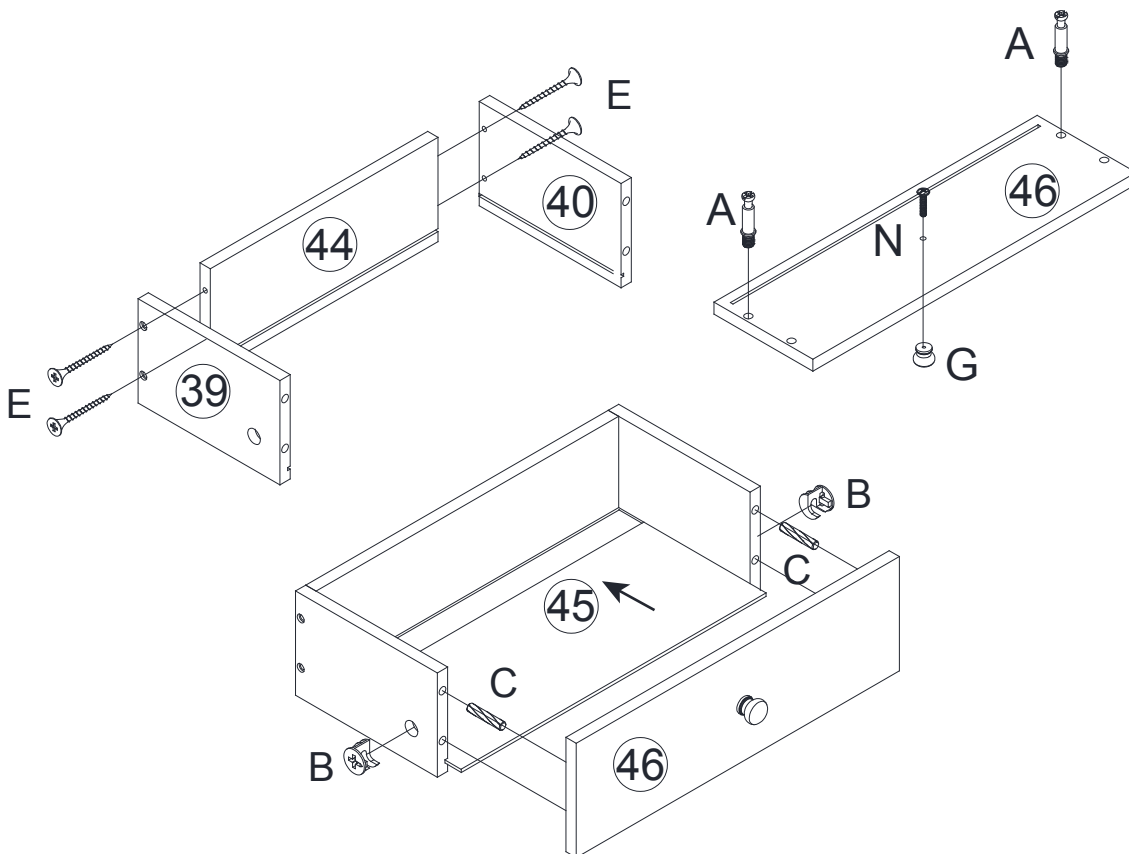

# STEP 33

A		2
B		2
E		4
N		1
C		2
G		1



# STEP 34

A		2
B		2
E		4
N		1
C		2
G		1

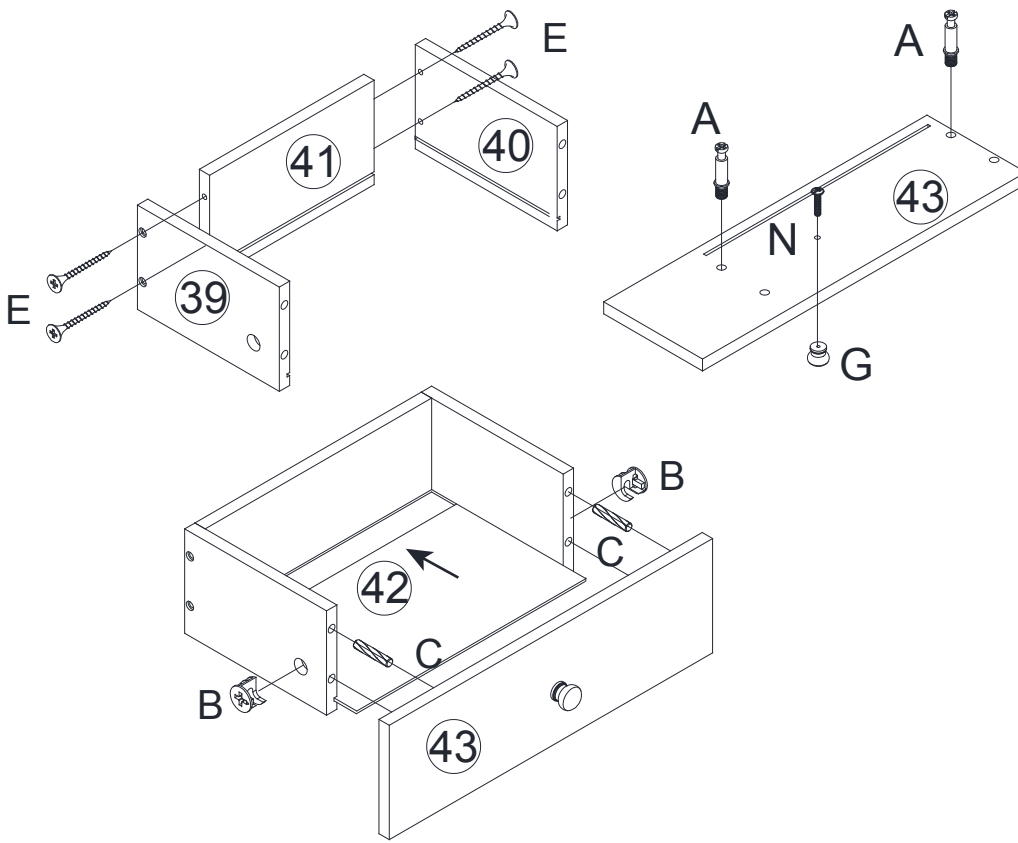

# STEP 35

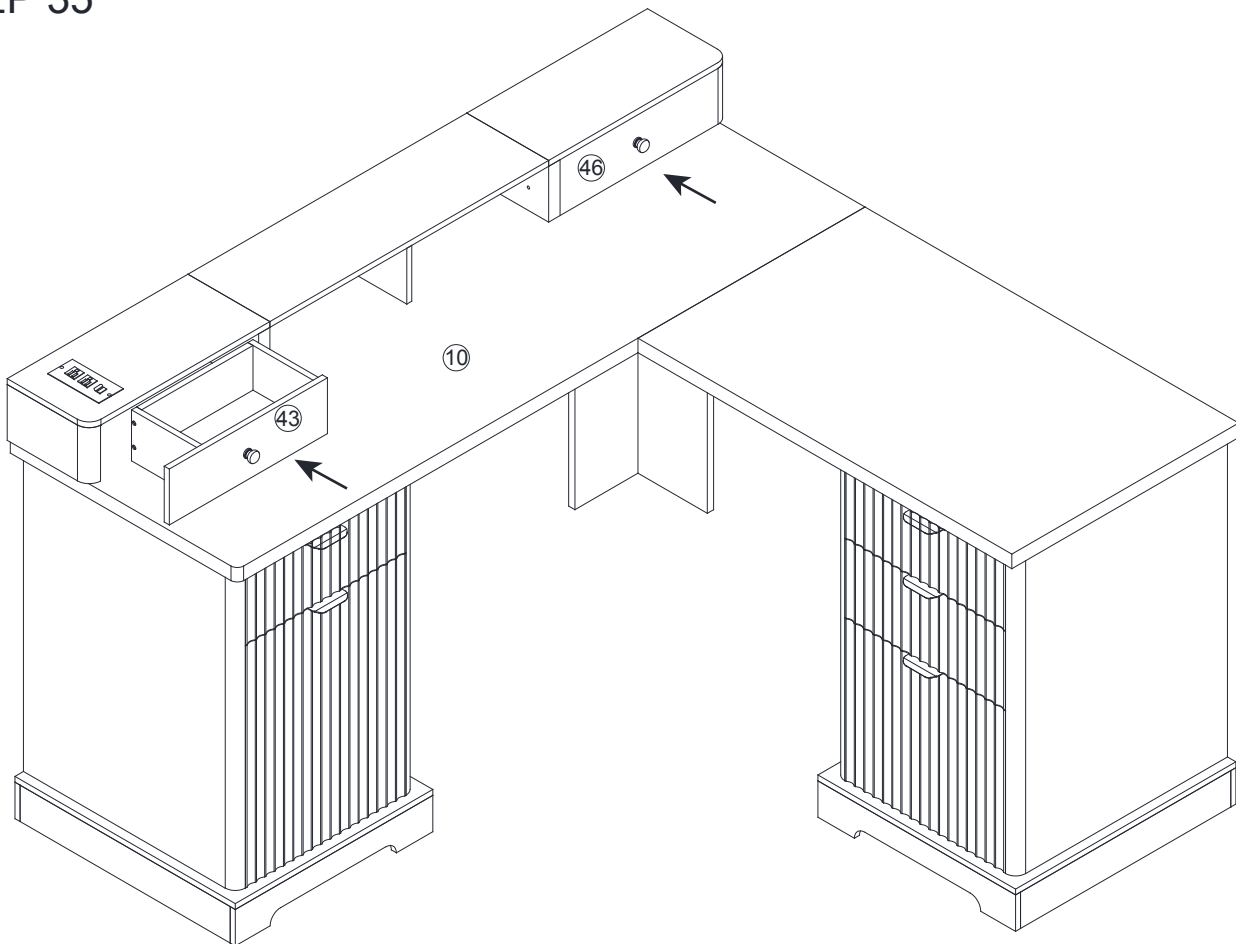

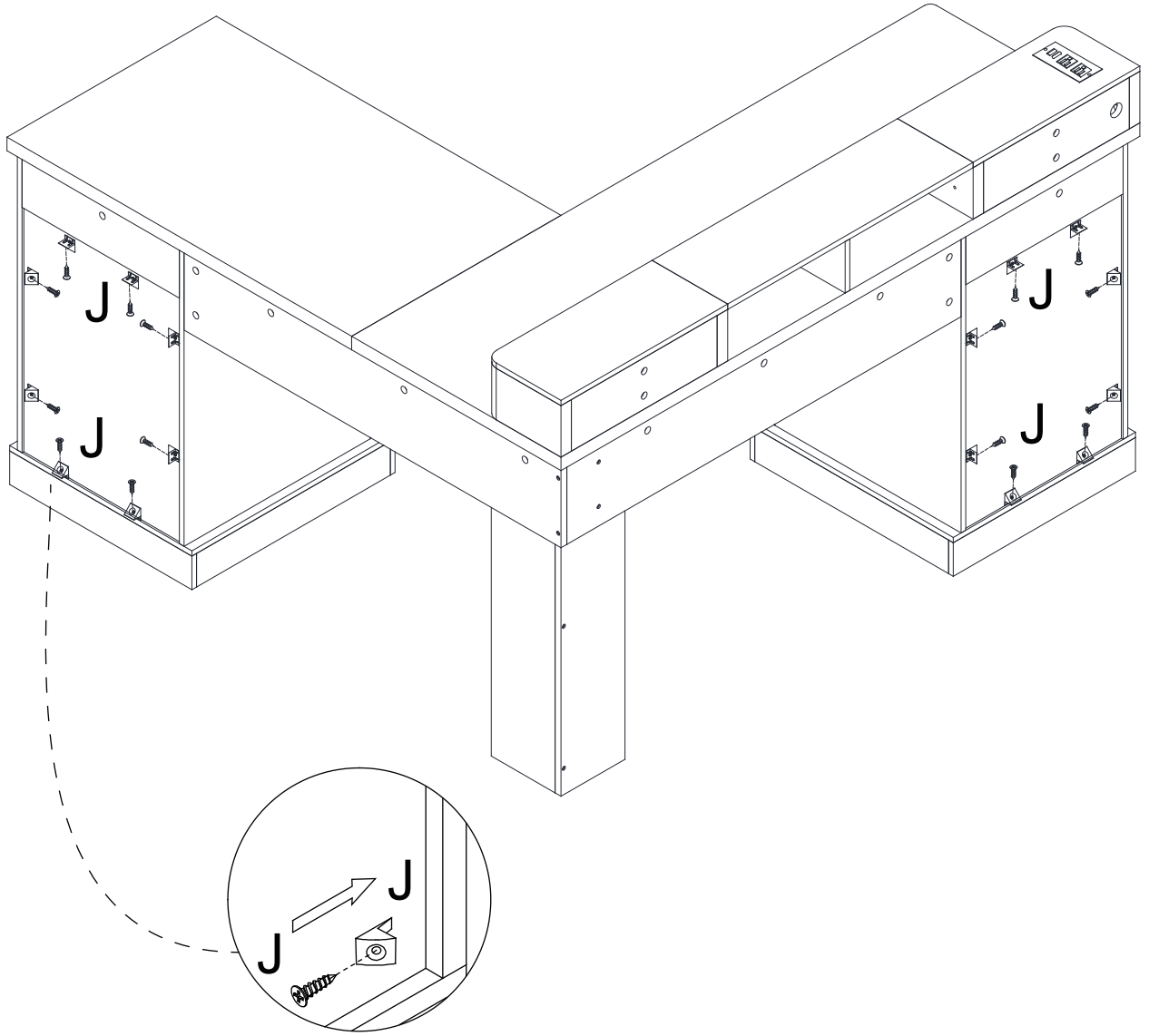

COMPLETE:

