

ASSEMBLY INSTRUCTION

Highland Acacia Adirondack Bar Table - VF 4107

IMPORTANT NOTE

- BEFORE BEGINNING ASSEMBLY, check that the quantities of the parts received match those on the parts list below. Carefully remove all the parts from the carton and put them individually on a soft cloth to prevent scratches or other damages occurring to the wood part.
- DO NOT TIGHTEN UP ALL THE BOLTS UNTIL EACH PART IS PROPERLY ASSEMBLED
- TOOL REQUIRED: Hex Wrench (provided)
- You should keep Hex Wrench in the safe place as you may need to tighten up the Head Cap Bolts periodically in the future.

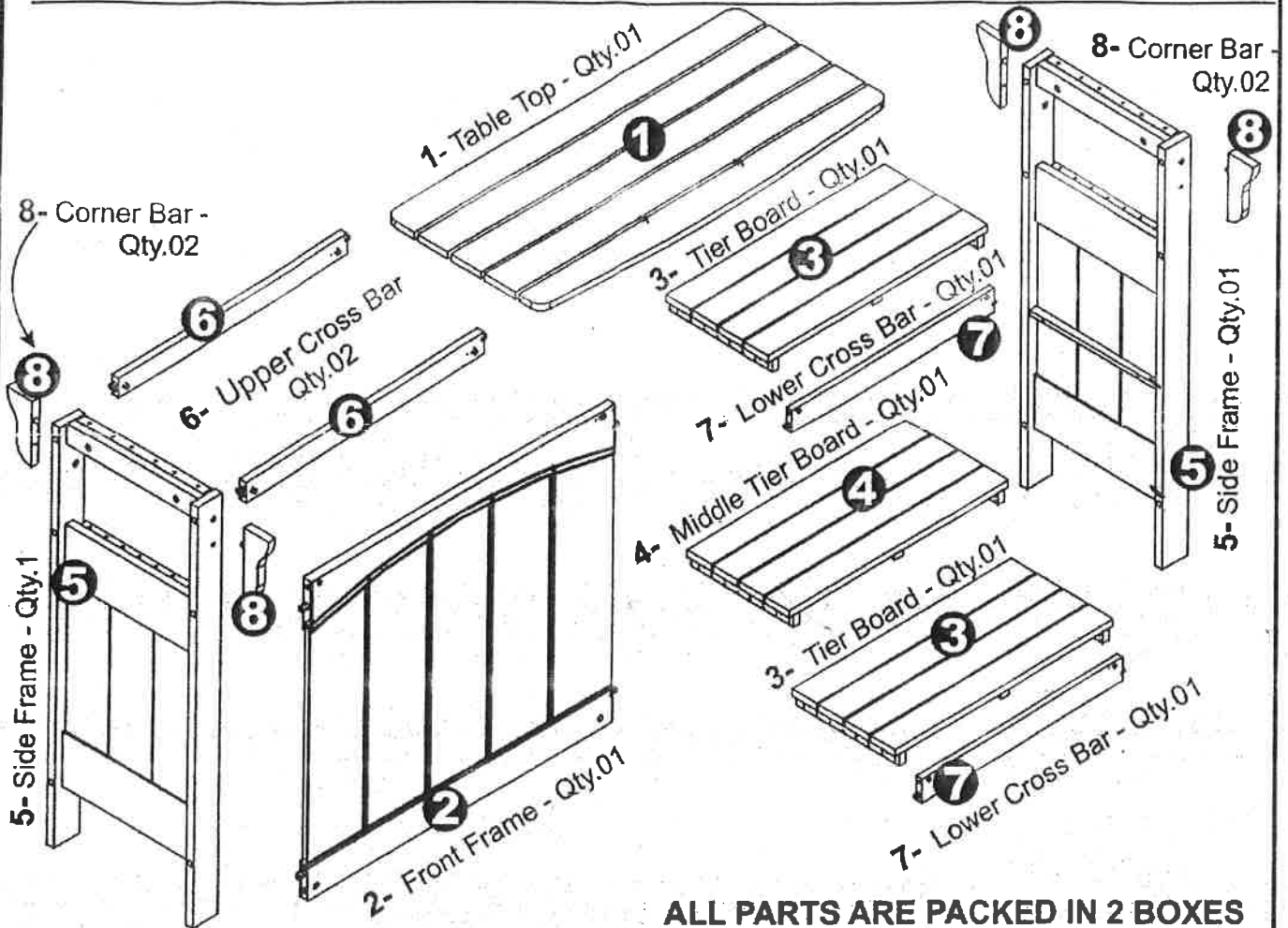

ALL PARTS ARE PACKED IN 2 BOXES

HARDWARE



A - 90 mm Hex Bolt & Barrel Nuts - Qty. 12

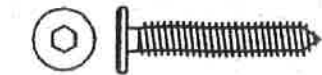

C - 30 mm Screw - Qty. 12

B - 45 mm Hex Bolt - Qty. 08

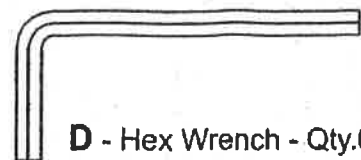

D - Hex Wrench - Qty.02

ASSEMBLY INSTRUCTION

Highland Acacia Adirondack Bar Table - VF 4107

STEP 1

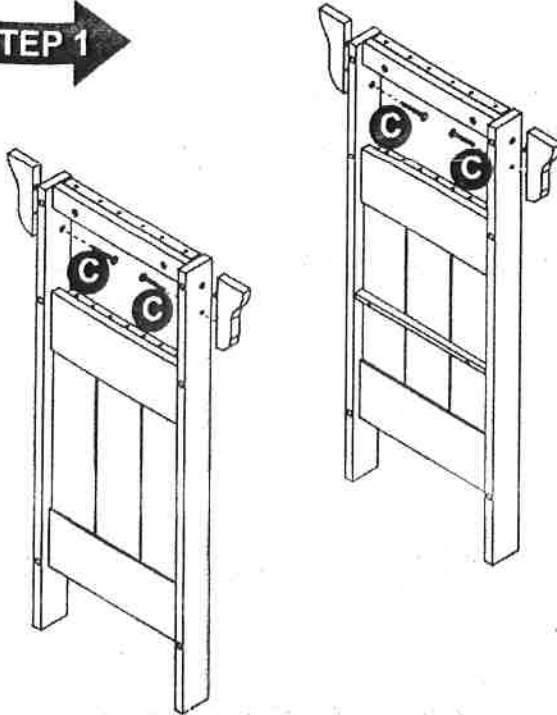

1 - Attach 4 Corner bars into the Side Frame as shown by 4 Screws (C), tighten all Screws carefully.

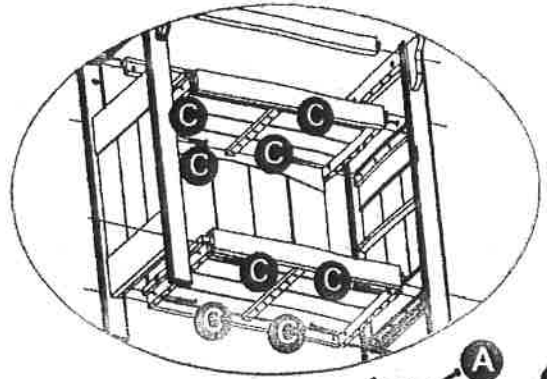

DO NOT TIGHTEN UP ALL THE SCREWS UNTIL EACH PART IS PROPERLY ASSEMBLED

STEP 2

2 - Place both 2 Side Frames at standing up position as shown
- Attach the Front Frame, Upper and Lower Cross Bar into both Side Frames by 12 Hex Bolts (A).
- Attach 2 Tier Boards(3) into both Side Frames by 8 Screws(c) as shown.

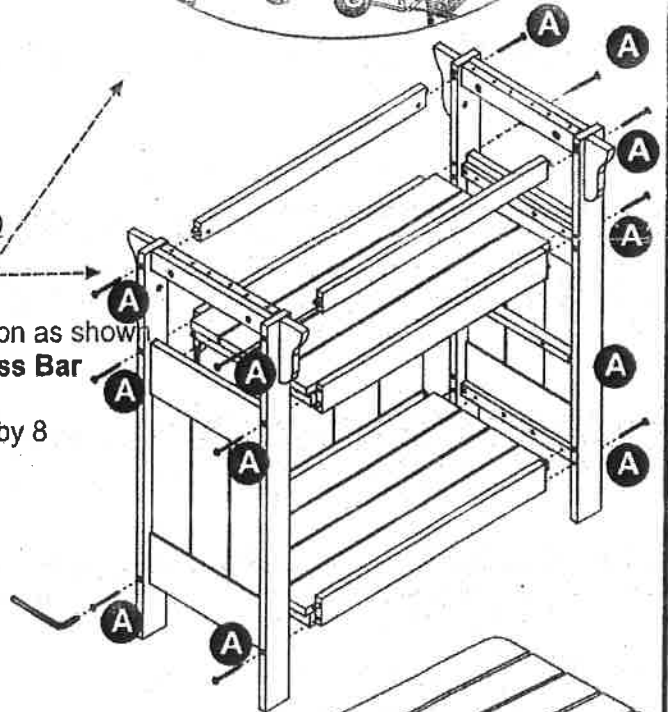

STEP 3

3 - Attach the Table Top into both Side Frames by 4 Hex Bolts (B) as shown

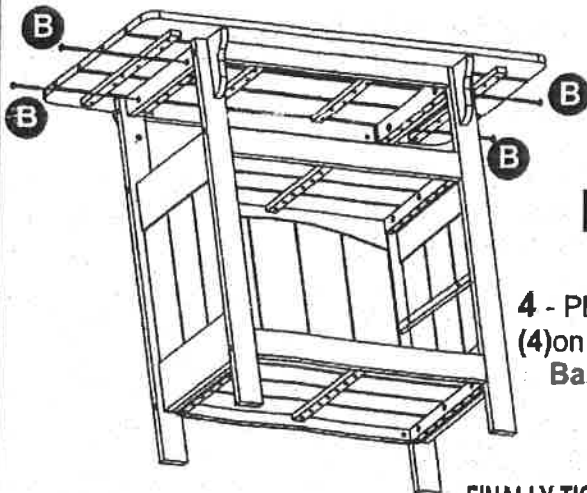

STEP 4

4 - Place Middle Tier Board (4) on the ready attached Bar

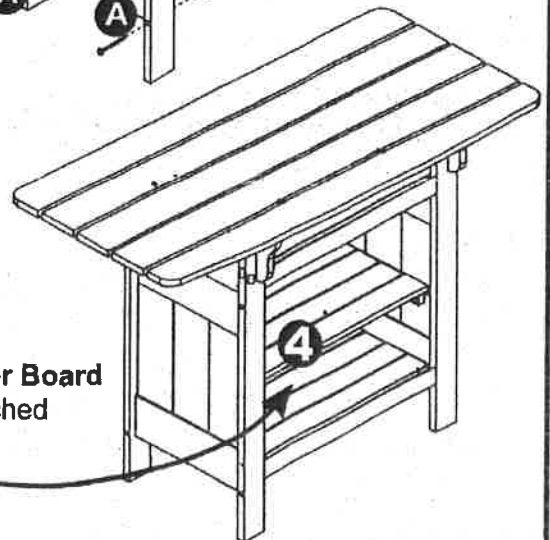

FINALLY TIGHTEN CAREFULLY ALL BOLTS AND SCREWS OF ASSEMBLED ABOVE

Be sure to tighten all Bolts before use