

Assembly Manual

Dining Table

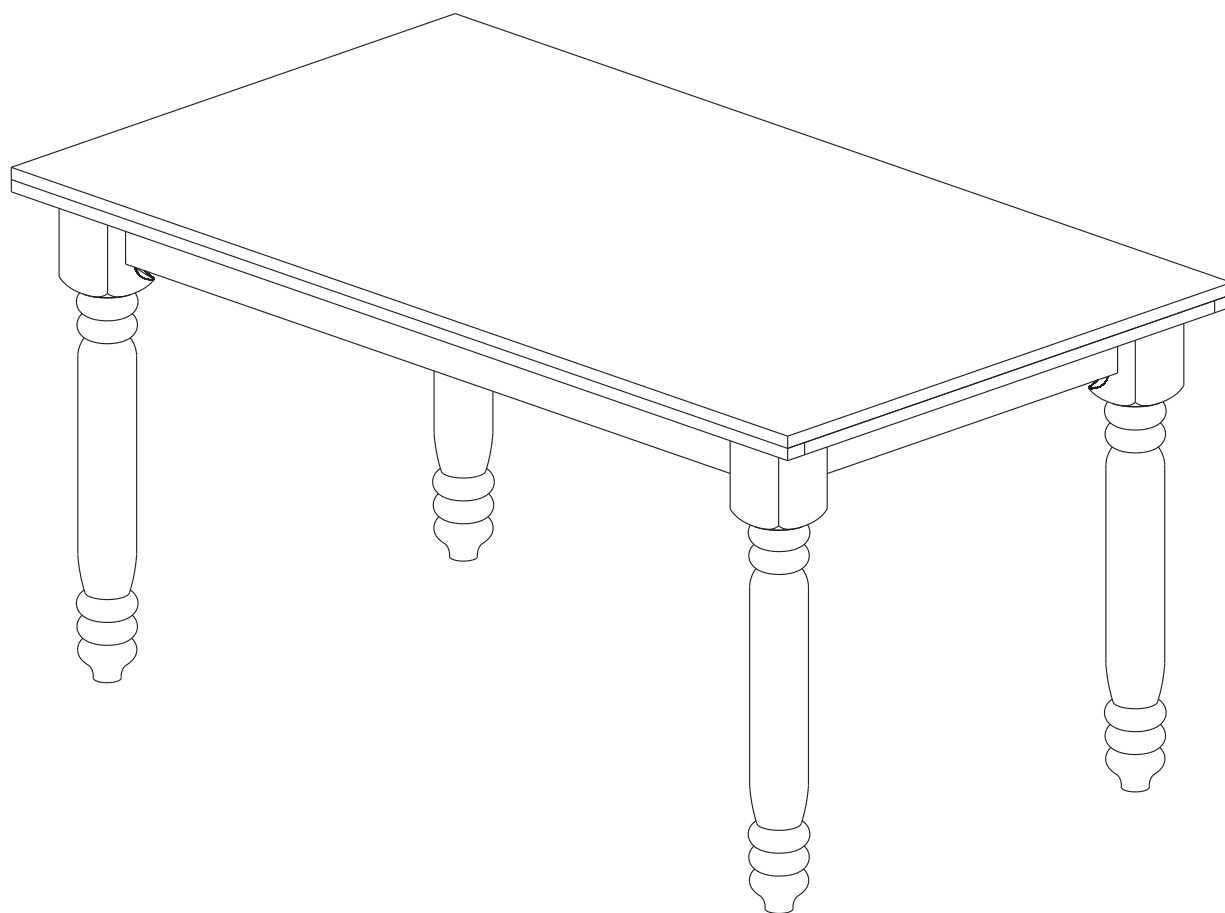

Please read this manual carefully before any operation and keep it properly for future use.

Assembly note:

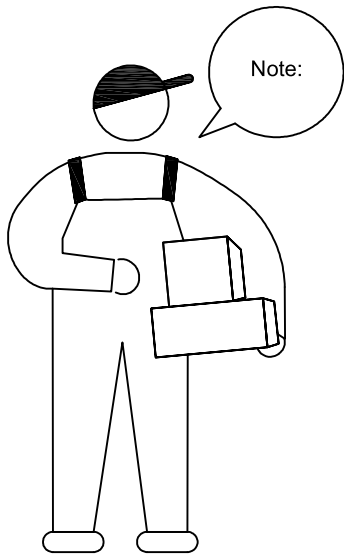

- Put a protective mat on the ground and handle the product with care.

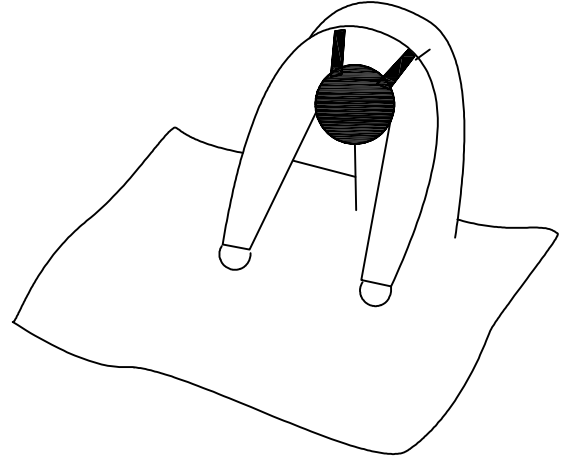

- Two people are preferred.

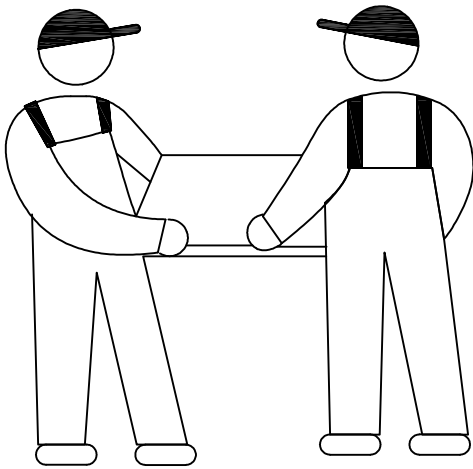

- Contact us if you have any confusions.

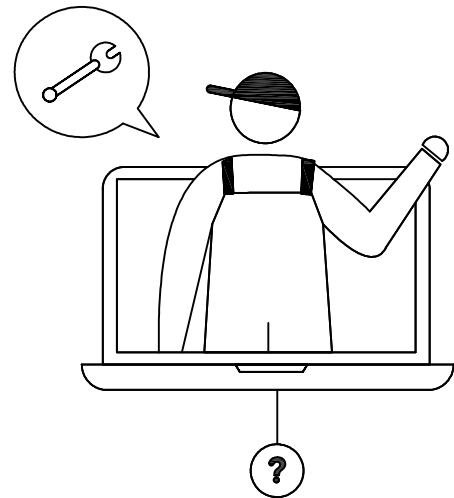



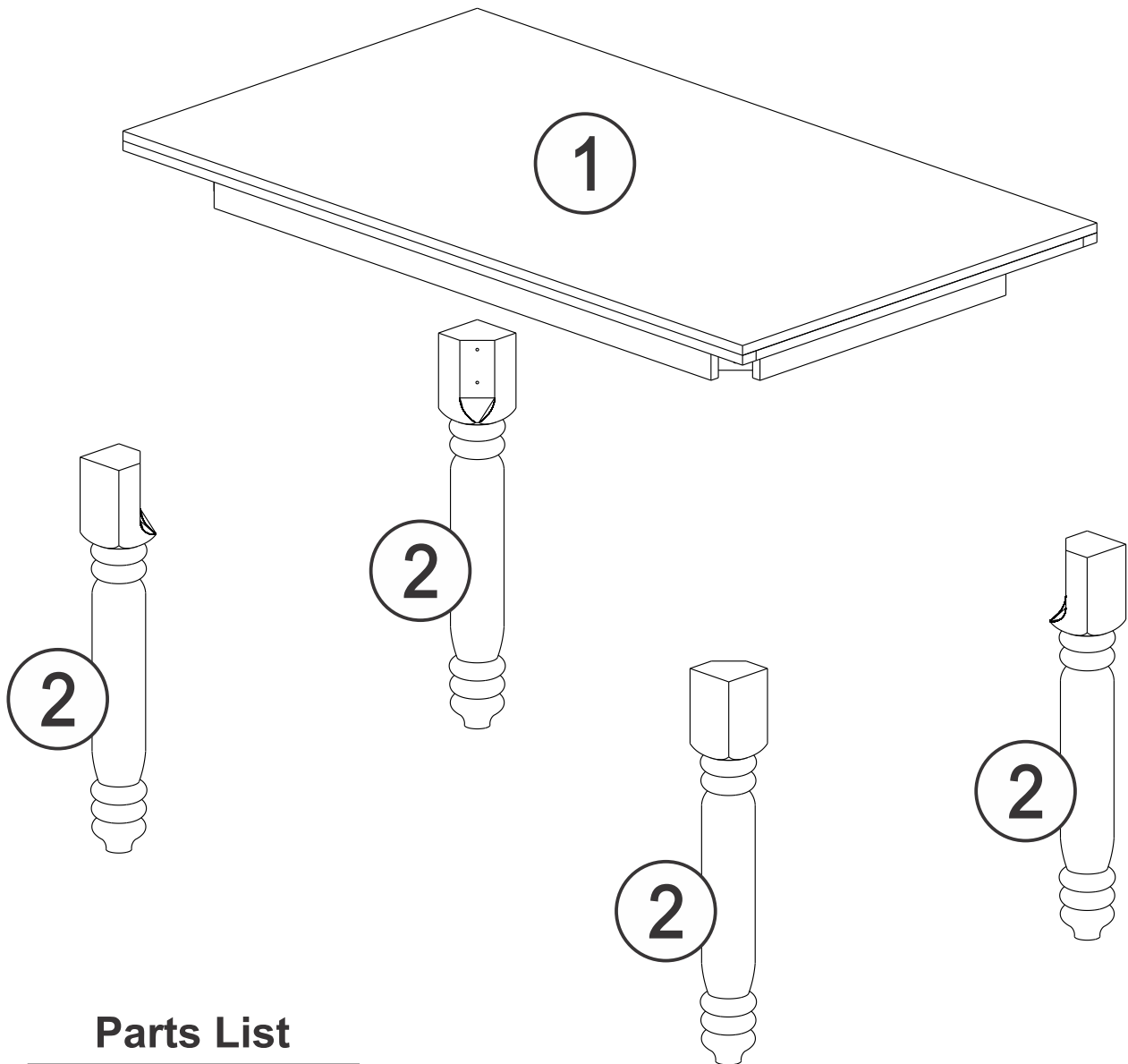

Parts List



Parts List

1- Top
2- Legs

Hardware List

A	Bolt	 M8X60	8+1
B	Allen Wrench		1
C	Rubber washer		8+1
D	Spring washer		8+1
E	Felt pad		4+1

Note: Qty after "+" is extra piece.

Step 1: Turn the table top over and attach the legs as shown in the picture. Do NOT screw them in completely so that you can make slight adjustments to the hole positions during the assembly process if necessary.

1

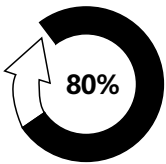

Screw in 80% or less.

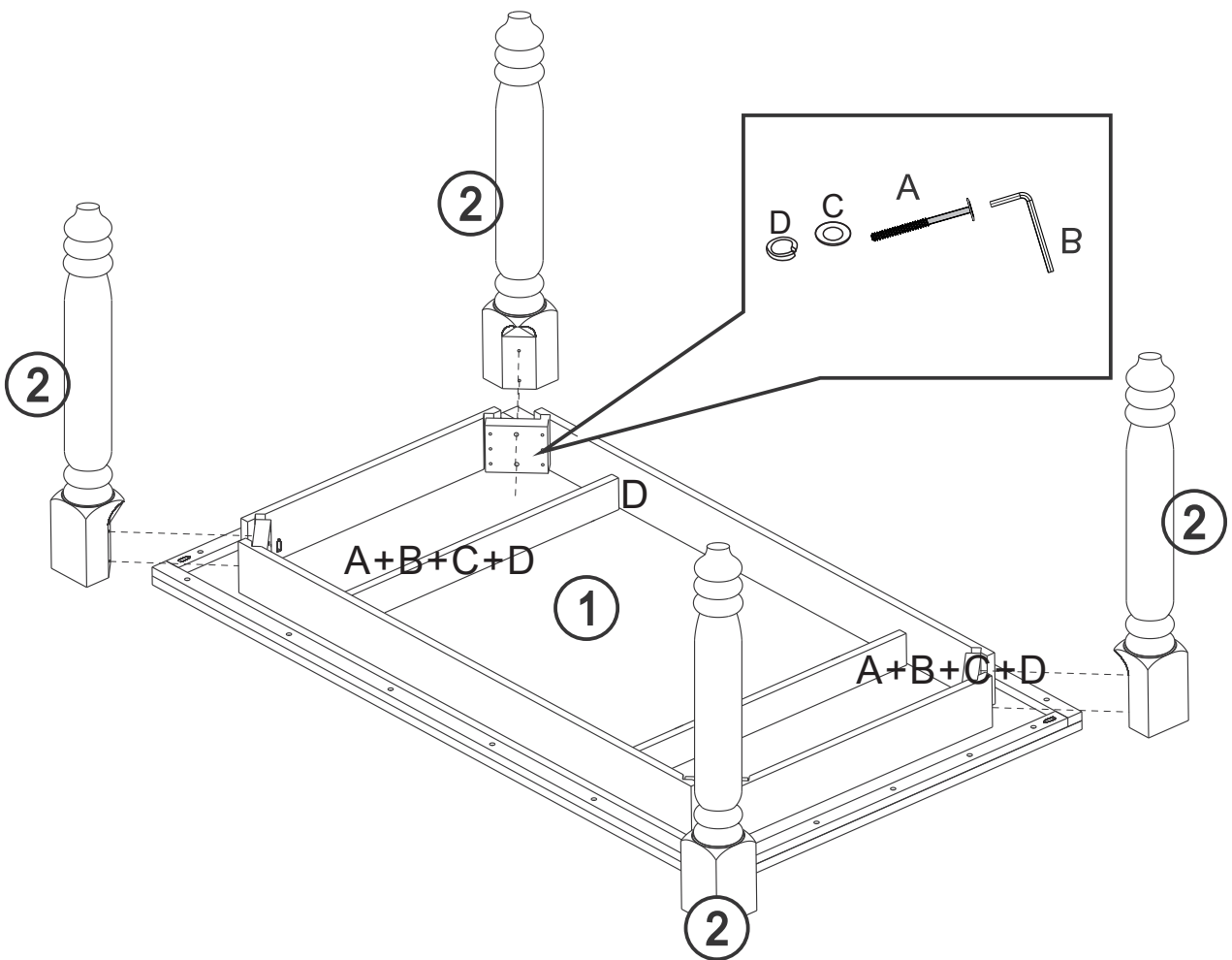

Step 2: Attach the leg pads to the bottom of the legs.

2

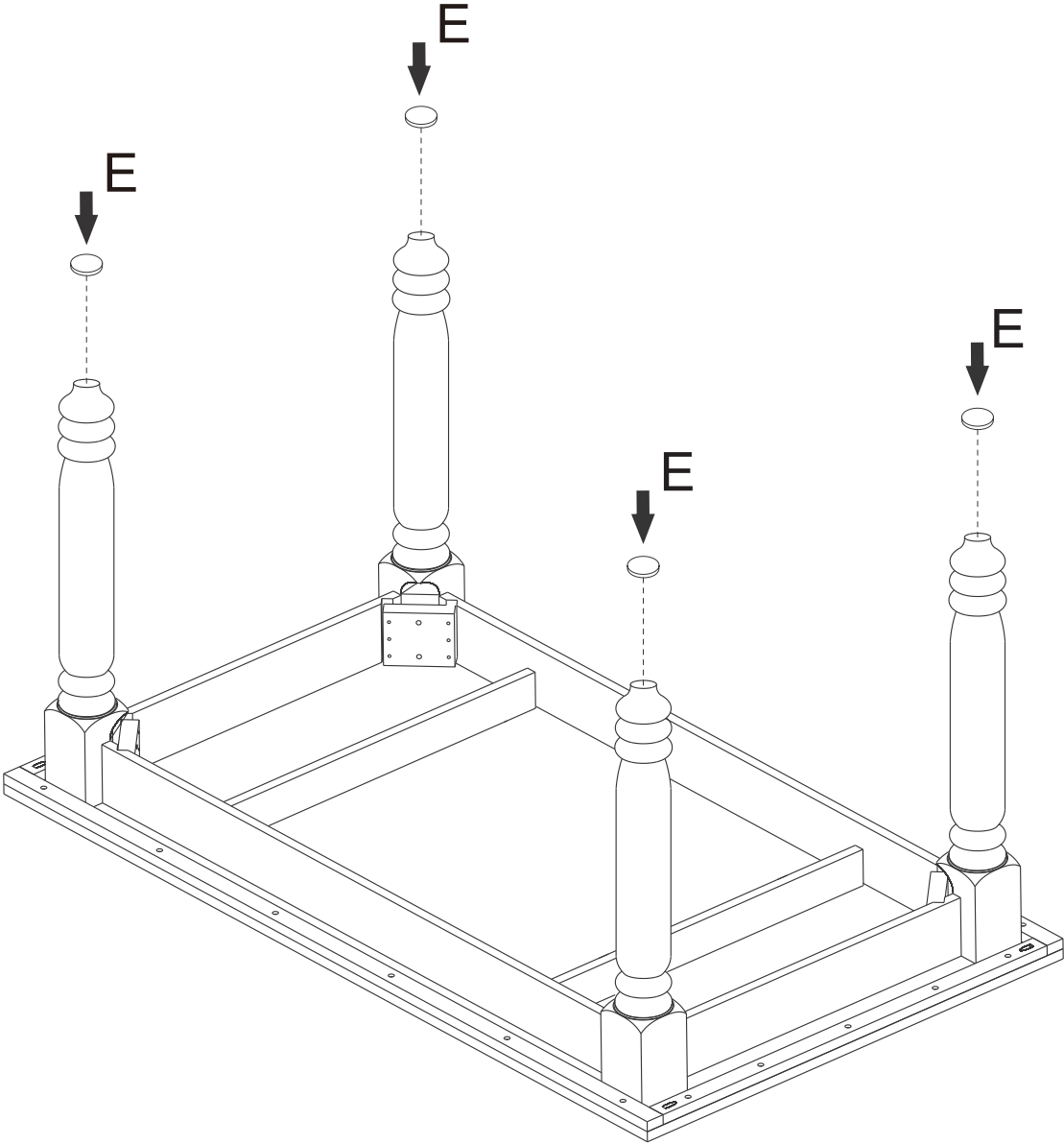

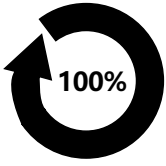

Screw all parts in 100% to ensure they are connected tightly and to ensure that the table is steady and safe.

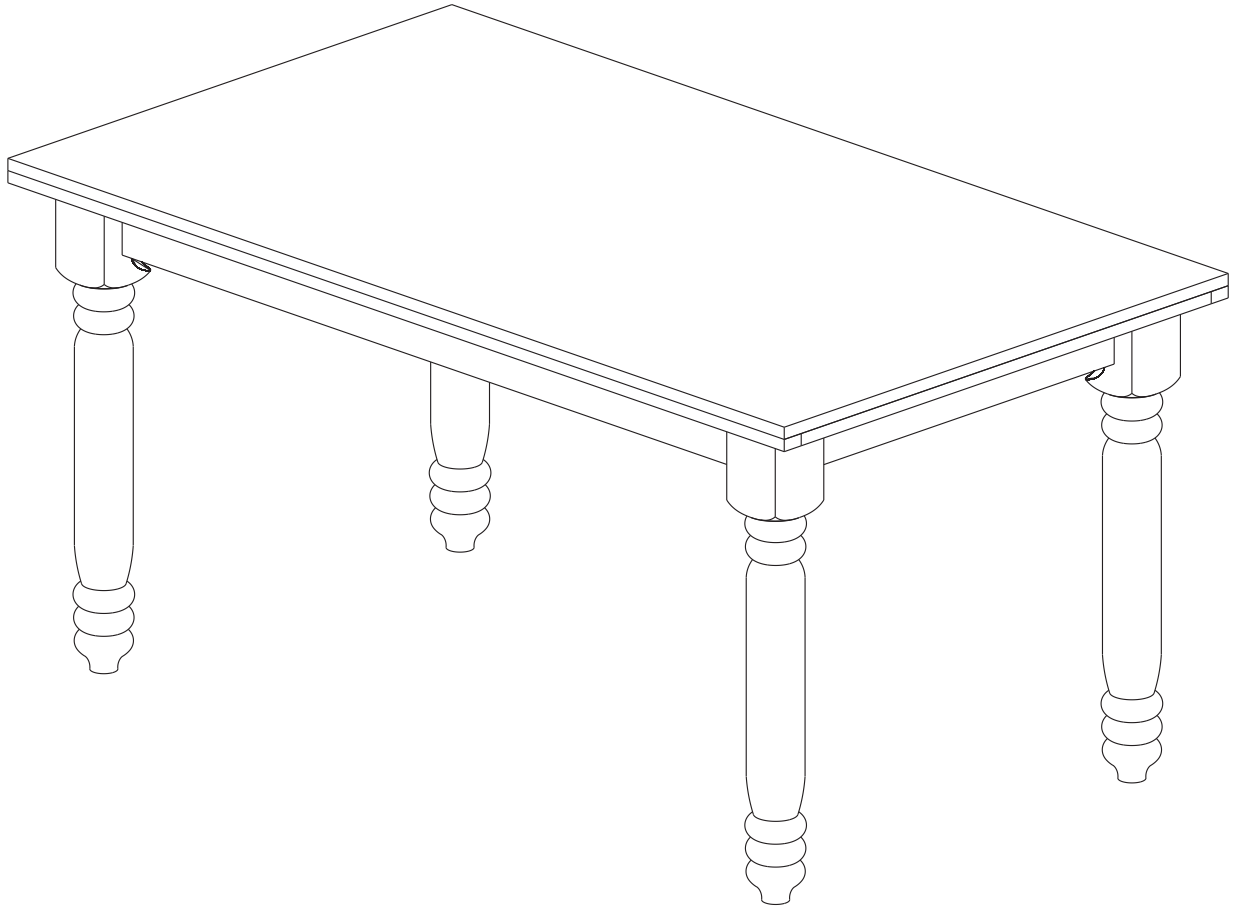

Done

Warning

- Please keep the product away from children while assembling.
- Do not let children play or jump on the product.
- Do not stand on the item or use as a step ladder.
- Prior to use, please check to see if there's any loosening screw or part.
- Make sure that each screw and part is correctly installed and securely fastened.

Care and Maintenance

- Use a soft clean cloth that will not scratch the surface when dusting.
- There's no need to use furniture polish. If you need, test it first in an inconspicuous area.
- Using solvents of any kind on your furniture may damage the finish.
- Never use water to clean your furniture as it may cause damage to the finish.
- Liquid spills should be removed immediately.
- Gently blot the spill with a soft clean cloth to avoid rubbing.

Further advice about the furniture care

- It is best to keep your furniture in a climate-controlled environment.
- Extreme temperatures and humidity changes can cause fading, warping, shrinking and spitting of wood.
- We recommend to keep furniture from sunlight exposure to avoid possible surface damage.
- Proper maintenance and cleaning at home will extend the life of your purchase.
- Following these important and helpful tips will help retain your furniture's performance even when it ages.
- Periodically (every 90 days) make sure the screws are fully tightened.