

# ASSEMBLY INSTRUCTIONS

MODEL #

**CM7245Q/F/T**

Questions?

GIVE US A CALL: 1-888-980-5122  
MON-FRI 8:30AM - 5:30PM (PT)

## TOOLS REQUIRED



Allen Wrench

(Included)



Phillips  
Screwdriver

(Not Included)

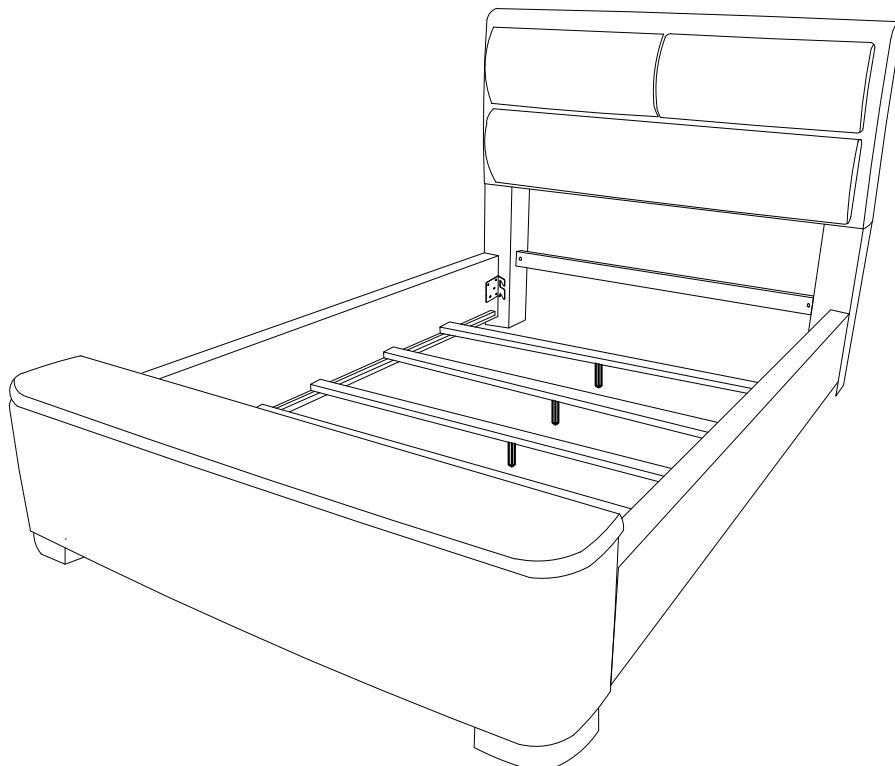

2 - People  
Recommended

## ASSEMBLY RATING



EASY → DIFFICULT

The Assembly Rating is a 5-point system showing the level of effort needed to assemble a specific product.



FOA Intro

Thank you for your purchase!

We hope you enjoy this new addition to your home for many years to come.

Our commitment to providing quality products does not simply end when you purchase our product. We fully stand behind our products from start to finish. Our customer service department is available Monday – Friday 8:30 AM – 5:30 PM Pacific Time and can help with assembly questions as well as, if necessary, replacing damaged or missing parts. To help expedite our service, please have these assembly instructions readily available, along with your order receipt.

 **Consumer Hotline**  
Toll-Free 1-888-980-5122

 **Monday to Friday**  
8:30AM- 5:30PM (PT)

 **WEBSITE**  
[www.foagroup.com](http://www.foagroup.com)

 **E-MAIL**  
[cs.ec@foagroup.com](mailto:cs.ec@foagroup.com)

    foagroup

 FurnitureOfAmerica

---

## CHECK BEFORE STARTING

**Are you missing anything?**  
Double-check all parts, hardware and accessories listed are all accounted for.

**Check out our Quick Tips!**  
We recommend reviewing the pre-assembly handouts. Even experts need a refresher now and then!

**Should we send any replacements?**  
Are there any irregularities or flaws in the parts? We can send replacements!

**Prep Time!**  
Please review the assembly instructions and all diagrams prior to assembling.

# PRE ASSEMBLY INTRODUCTION

We understand building ready-to-assemble furniture can be a challenging experience for some. To help avoid confusion, we have provided some helpful tips that may speed up the process.



## Teamwork

ALWAYS have at least two people to help with transporting and assembling the product to avoid potential injury and/or damage.

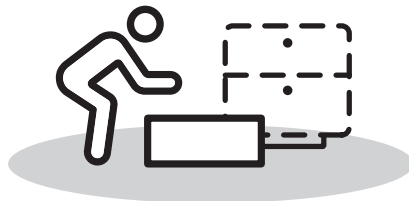
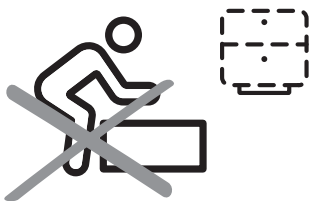

## Suitable Location

Assembling near the area of the intended location is highly recommended.



## Sufficient Space

Make sure you have enough space to move around during the assembly.

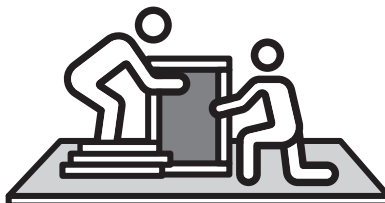

## Avoid Scratches

Use cardboard, blankets or a carpeted area while assembling furniture to prevent to prevent scratches and damages.

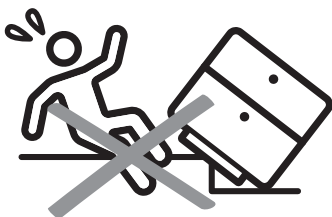

## Flat Surface

Make sure the furniture rests on a flat and level surface with each leg evenly touching the floor.

# ASSEMBLY AND CARE ADVICE



**FAILURE TO FOLLOW THE GUIDELINES BELOW MAY RESULT IN INJURY AND/OR PROPERTY DAMAGE.**



Position each part correctly and insert screws or bolts into their respective holes.



Turn clockwise to tighten and only tighten when step is completed or when instructed to do so.



Use the appropriate hand tools or power tools for assembly. Select steps, such as tightening screws and/or bolts, may require hand tools to avoid causing damage during assembly.



Save the instructions and store any supplied tools for later maintenance.



After two weeks, check and tighten any loose hardware and repeat again every six months thereafter.

**IT IS THE USER'S RESPONSIBILITY TO MAINTAIN THE FURNITURE. THE HARDWARE MAY LOOSEN OVER TIME AND MAY CAUSE THE FURNITURE TO BE WOBBLY AND UNABLE TO SUPPORT ITS INTENDED WEIGHT CAPACITY. THIS MAY LEAD TO COLLAPSE AND MAY CAUSE SERIOUS INJURY.**

# BED

CM7245/Q/F/T

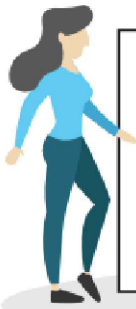

- Please keep instructions for future reference.
- Check the quantity and irregularity of parts and hardware before you start.

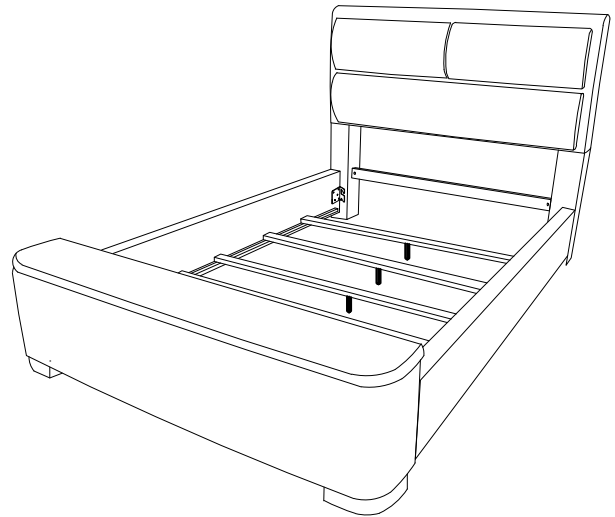

## PARTS

#1 1pc

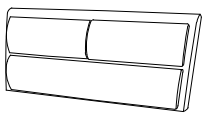

Headboard

#2 2pcs

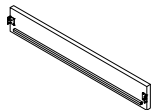

Side Rail

#3 1pc

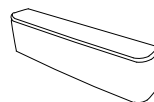

Footboard

#4 2pcs



FB Foot

#5 4pcs



Support leg  
95x30x30mm

#6 4pcs

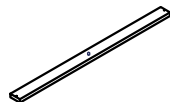

Slat

#7 1pc



HB Support Rail

#8 2pcs

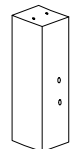

HB Leg (L/R)

## HARDWARE

#A 8pcs



Bolt  
Ø5/16" x 1"

#B 6pcs



Bolt  
Ø5/16" x 3/4"

#C 18pcs



Lock Washer  
Ø5/16"

#D 14pcs



Flat Washer  
Ø5/16" x 19mm

#E 4pcs



Flat Washer  
Ø5/16" x 22mm

#F 1pc



Allen Wrench  
5mm

#G 4pcs



Hex Nut Ø5/16"

#H 4pcs



Threaded Stud  
Ø5/16" x 3-1/4"

#I 14pcs

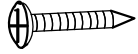

Screw  
Ø5/16" x 38mm

#J 1pc

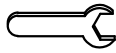

Wrench

#K 2pcs







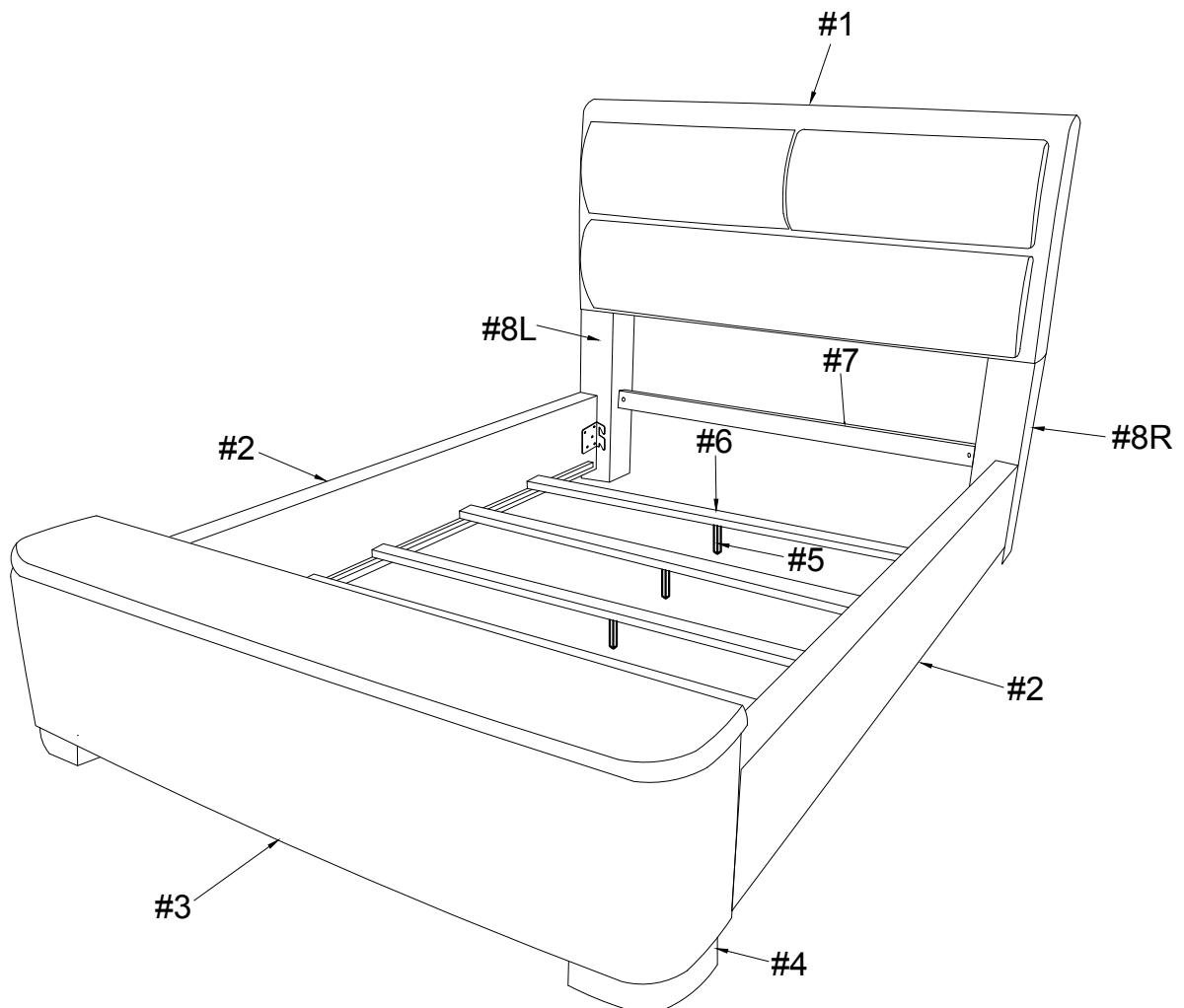



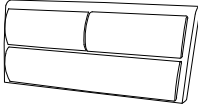
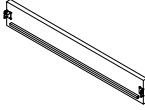
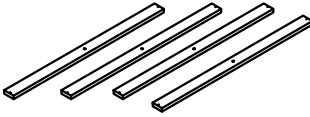

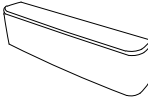



Connecting iron

## Exploded View

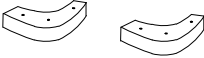
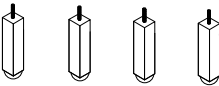
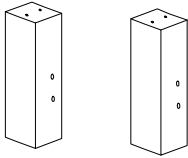

# CM7245Q/F/T is packed in 3 cases

Carton	Disignation	Part	Hardware
CM7245Q/F/T -HB	Headboard		
CM7245Q/F/T -R	Side Rail (2pcs)		
	Slat (4pcs)		
	HB Support Rail		
CM7245Q/F/T -FB	Footboard		 #A x 8pcs  #B x 6pcs  #C x 18pcs  #D x 14pcs  #E x 4pcs  #F x 1pc  #G x 4pcs  #H x 4pcs  #I x 14pcs  #J x 1pc  #K x 2pcs
	Foot board Leg (2pcs)		
	Support leg (4pcs)		
	Head board leg (2pcs)		

# ASSEMBLY INSTRUCTIONS

## 1

Part #3 x1pc

Part #4 x2pcs

Hardware #1 x6pcs

Attach FB Foot (#4) to the Footboard (#3) by using Screws (#1).

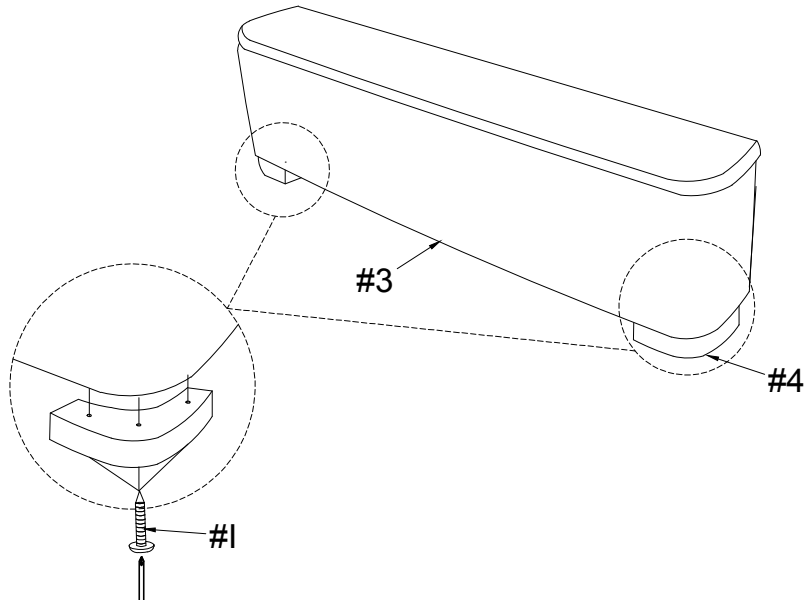

## 2

Part #1 x1pc

Part #8 x2pcs

Hardware #C x4pcs

Hardware #E x4pcs

Hardware #H x4pcs

Hardware #G x4pcs

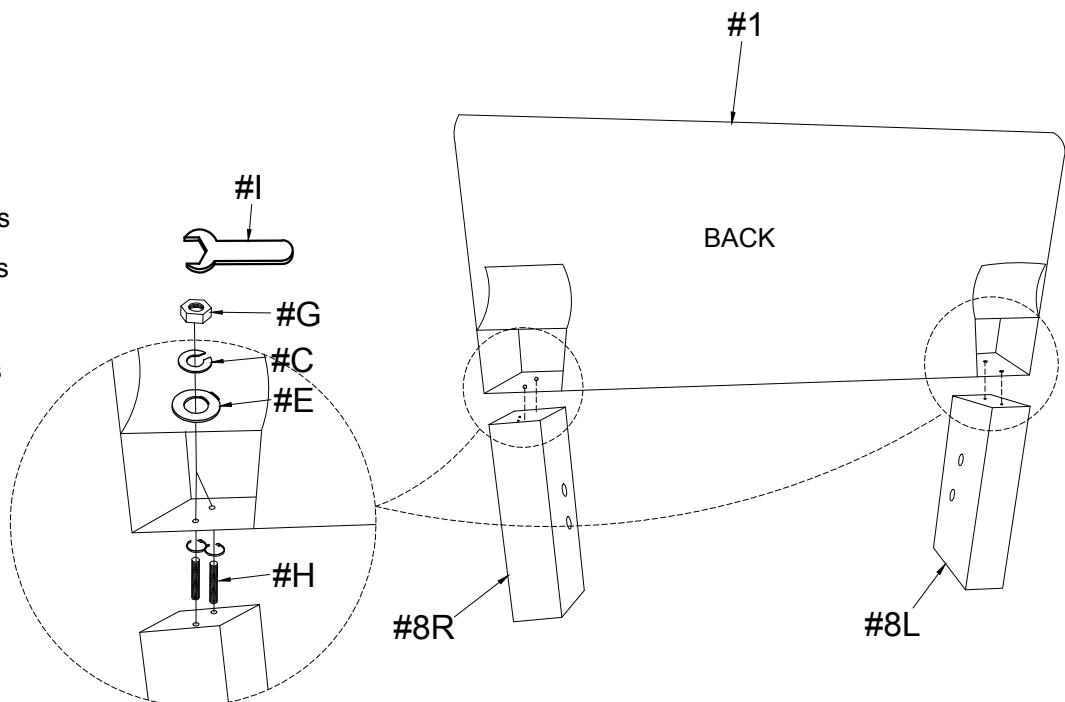

Insert threaded studs (#H) into HB Legs (#8). Lift the velcro lining and align HB legs (#8) to the Headboard (#1), then secure by using washers (#E,C) with hex nut (#G).

# ASSEMBLY INSTRUCTIONS

## 3

Part #7 x1pc

Hardware #B x 6pcs

Hardware #C x 6pcs

Hardware #D x 6pcs

Hardware #K x2pcs

Align the HB Support Rail (#7) to the L/R HB Legs (#8) and secure using Bolts (#B) with Washers (#C,D).

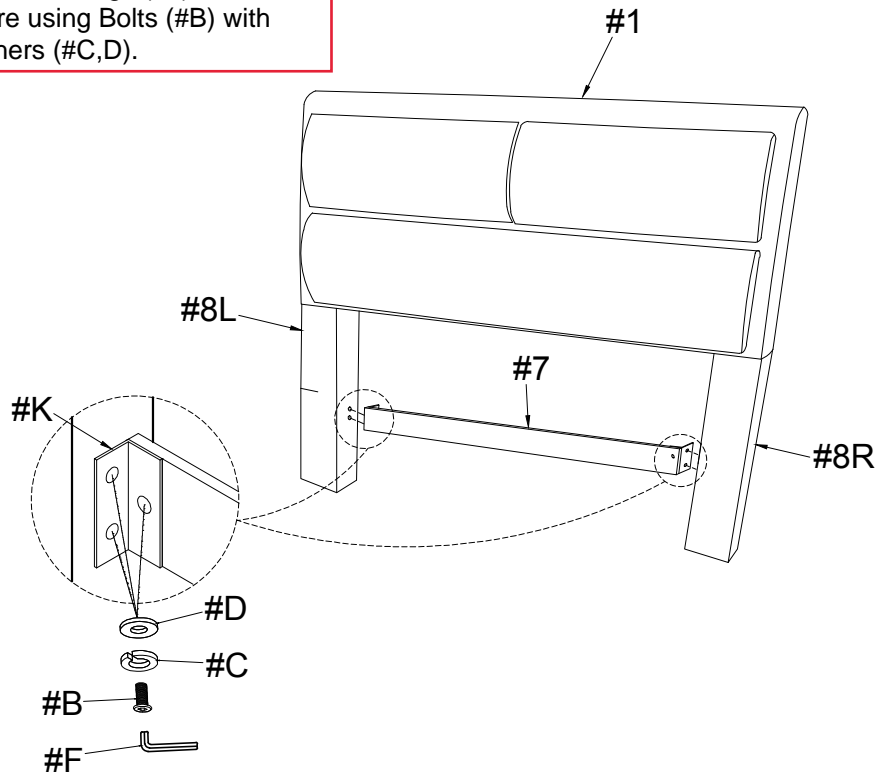

## 4

Part #2 x2pcs

Hardware #A x8pcs

Hardware #C x8pcs

Hardware #D x8pcs

Insert Bolts (#A) with washers (#C,D) onto the HB LEGS (#8) and the Footboard (#3). Then hook side rails (#2) onto the bolts and finish tightening the bolts through.

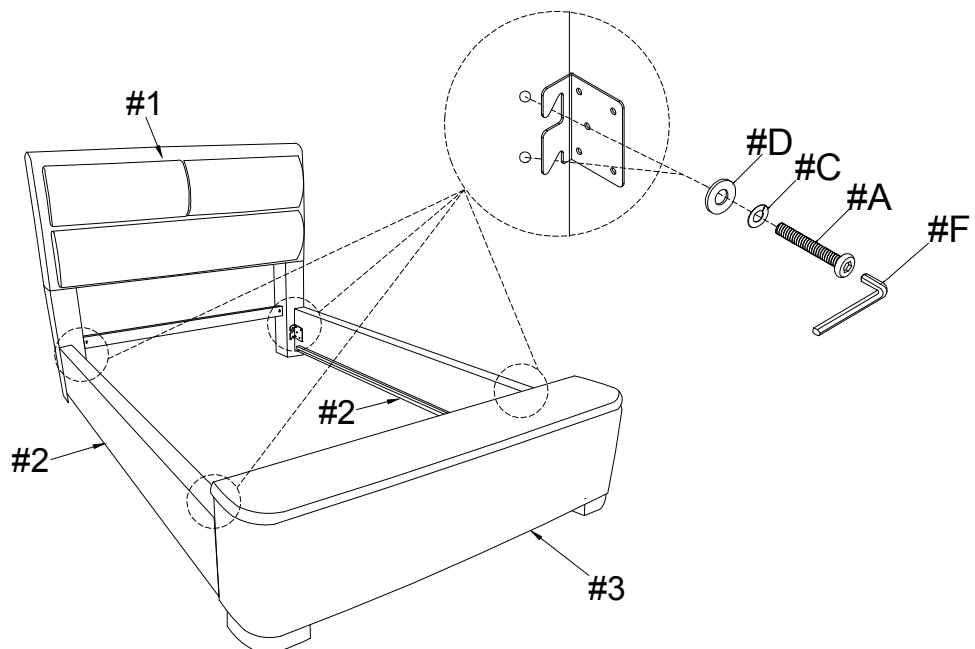

# ASSEMBLY INSTRUCTIONS

## 5

Part #5 x1pc

Part #6 x1pc

Align the support leg (#5) to the slat (#6). Adjust the leveler of the support legs (#7) according to the ground level.

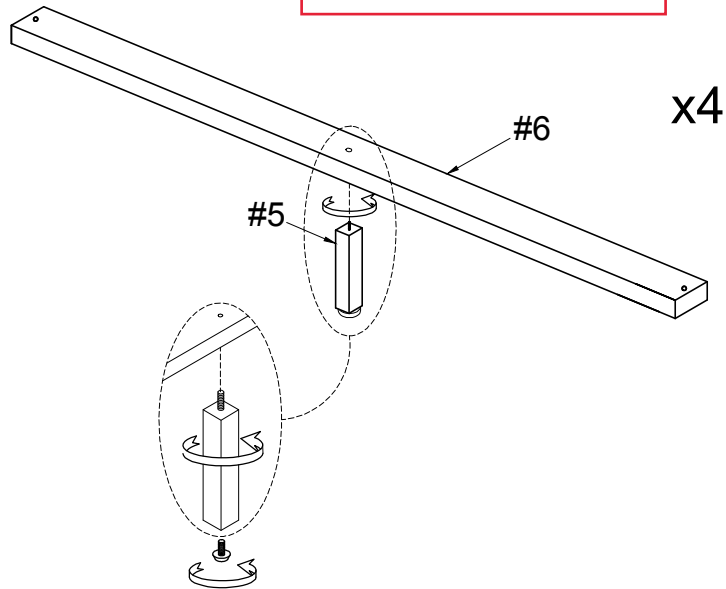

## 6

Hardware #1 x8pcs

Align slats (#6) to the side rails (#2) and secure using Screws (#1).

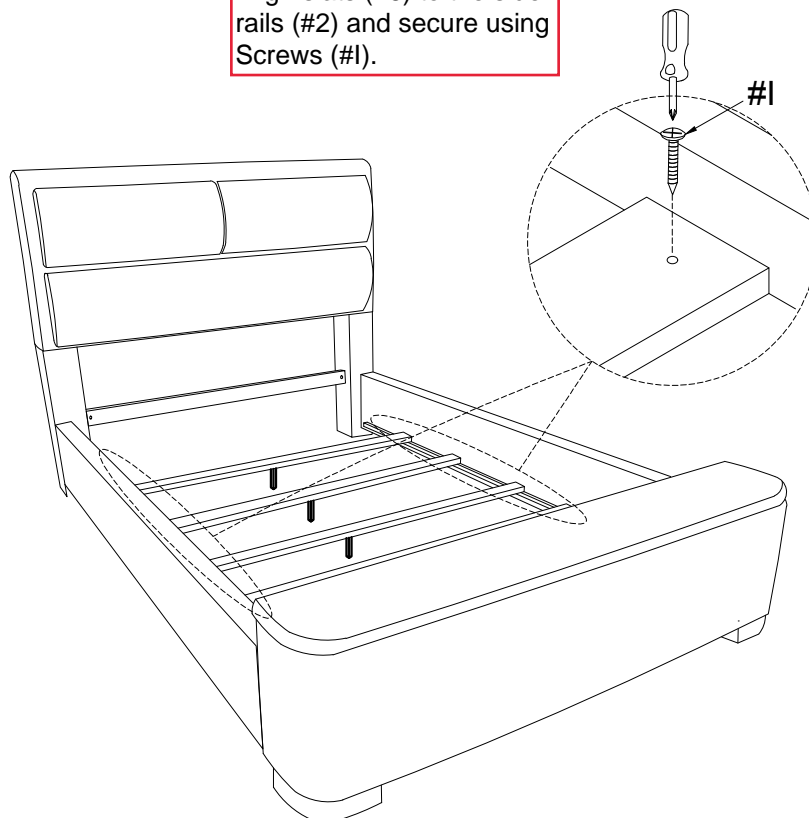

# ASSEMBLY INSTRUCTIONS

7

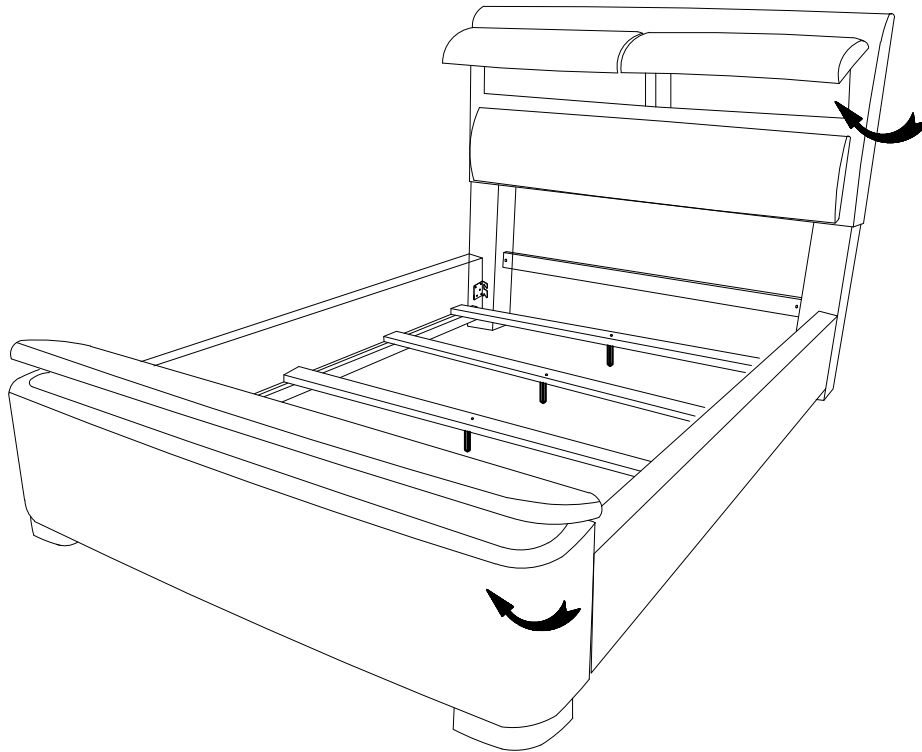

## ASSEMBLY COMPLETED



Please ensure the furniture rests on an even and flat surface. If the product wobbles or feels loose, double-check all bolts and/or screws are properly tightened and secured.



### Keep this handy!

Please retain this instruction manual and any order-related information for future reference.



### Lift, don't drag!

To avoid damage to product please always LIFT the product when transporting or adjusting the placement.