

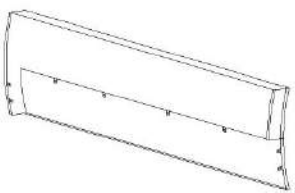





ASSEMBLY INSTRUCTIONS (THREE SEATER SOFA)

BEFORE YOU START ASSEMBLING YOUR FURNITURE:

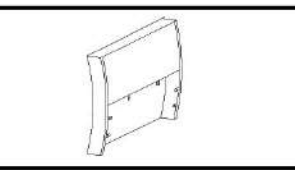
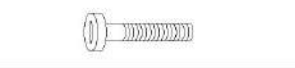
- CHECK THAT YOU HAVE ALL THE PIECES LISTED ON THE LEFT HAND SIDE.
- LAY A CLEAN SHEET ON A FLAT SURFACE BIG ENOUGH TO ASSEMBLE YOUR FURNITURE ON IN ORDER TO PROTECT YOUR FURNITURE.

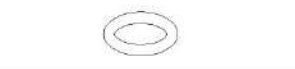
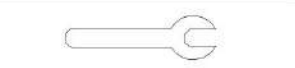
A	1	
B	1	
C	1	
D	12	
E	12	
F	12	
G	1	
H	1	

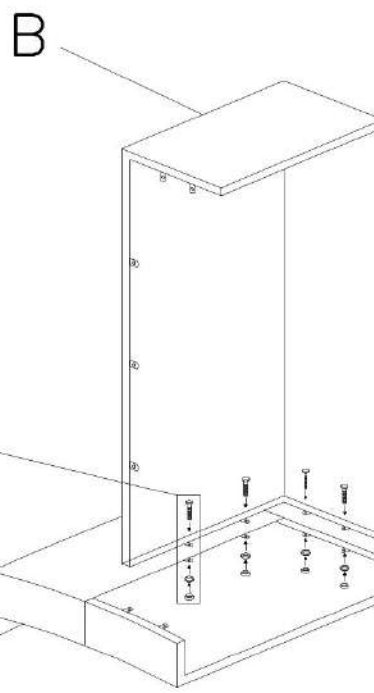

1.

Attach sofa side (C) to the right hand side of sofa base (B). Align the bolt brackets of both (B) and (C) in the position shown in the diagram above. For each of the connecting bolt brackets, insert bolt (D) through the brackets through a washer (F) and secure with a nut (E). Loosely tighten with the Allen key (H) and spanner (G) until all the bolts have been put in place. Then go over each bolt and fully tighten.

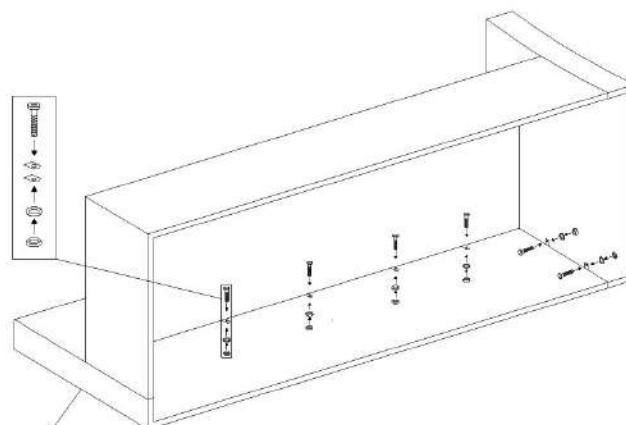

2. A



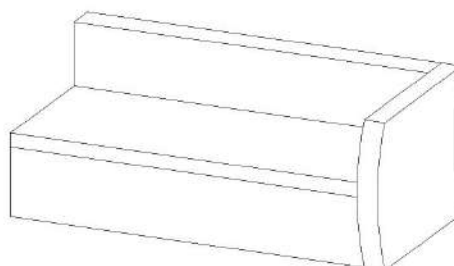



Attach sofa back (A) to sofa base (B) and sofa side (C). Align the bolt brackets of (A) with those of (B) and (C) as shown in the diagram above. For each of the connecting bolt brackets, insert bolt (D) through the brackets through a washer (F) and secure with a nut (E). Loosely tighten with the Allen key (H) and spanner (G) until all the bolts have been put in place. Then go over each bolt and fully tighten.

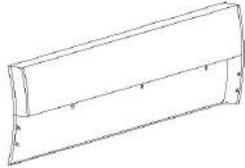

ASSEMBLY INSTRUCTIONS (DOUBLE SOFA)

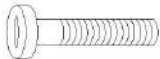
BEFORE YOU START ASSEMBLING YOUR FURNITURE:

- CHECK THAT YOU HAVE ALL THE PIECES LISTED ON THE LEFT HAND SIDE.
- LAY A CLEAN SHEET ON A FLAT SURFACE BIG ENOUGH TO ASSEMBLE YOUR FURNITURE ON IN ORDER TO PROTECT YOUR FURNITURE.

A	1	
B	1	
C	1	
D	11	
E	11	
F	11	
G	1	
H	1	

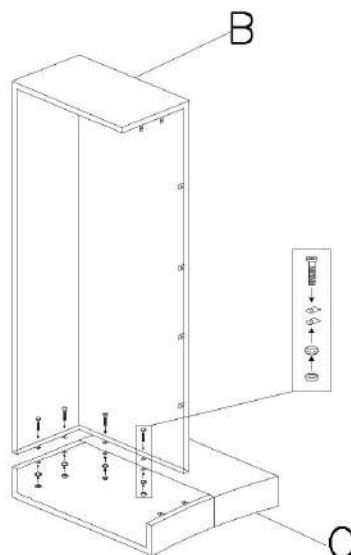

1.

Attach sofa side (C) to the left hand side of sofa base (B). Align the bolt brackets of both (C) and (B) in the position shown in the diagram above. For each of the connecting bolt brackets, insert bolt (D) through the brackets through a washer (F) and secure with a nut (E). Loosely tighten with the Allen key (H) and spanner (G) until all the bolts have been put in place. Then go over each bolt and fully tighten.

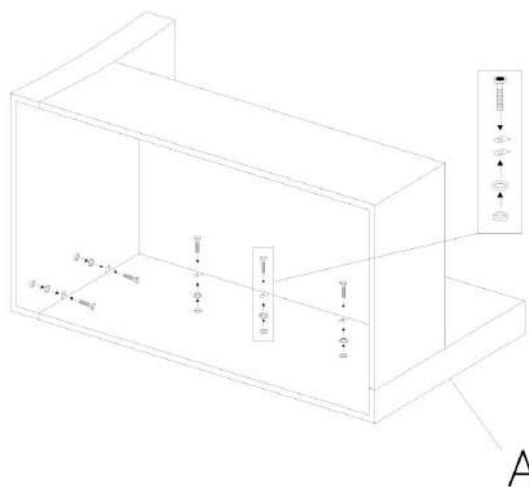

2.

Attach sofa back (A) to sofa base (B) and sofa side (C). Align the bolt brackets of (A) with those of (B) and (C) as shown in the diagram above. For each of the connecting bolt brackets, insert bolt (D) through the brackets through a washer (F) and secure with a nut (E). Loosely tighten with the Allen key (H) and spanner (G) until all the bolts have been put in place. Then go over each bolt and fully tighten.

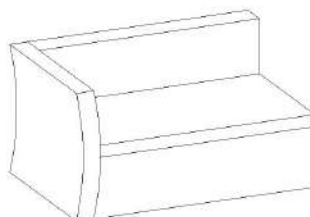

ASSEMBLY INSTRUCTIONS (SINGLE SOFA)

BEFORE YOU START ASSEMBLING YOUR FURNITURE:

- CHECK THAT YOU HAVE ALL THE PIECES LISTED ON THE LEFT HAND SIDE.
- LAY A CLEAN SHEET ON A FLAT SURFACE BIG ENOUGH TO ASSEMBLE YOUR FURNITURE ON IN ORDER TO PROTECT YOUR FURNITURE.

A	2	
B	1	
C	1	
D	12	
E	12	
F	12	
G	1	
H	1	

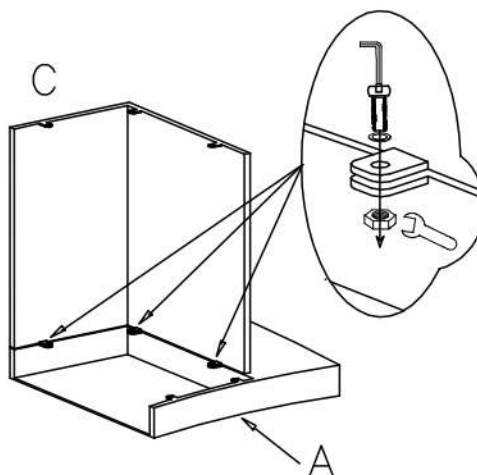

1.

Attach one of sofa side (A) to the left hand side of sofa base (C). Align the bolt brackets of both (A) and (C) in the position shown in the diagram above. For each of the connecting bolt brackets, insert bolt (D) through a washer (E), through the bolt brackets and secure with a nut (F). Loosely tighten with the Allen key (G) and spanner (H) until all the bolts have been put in place. Then go over each bolt and fully tighten.

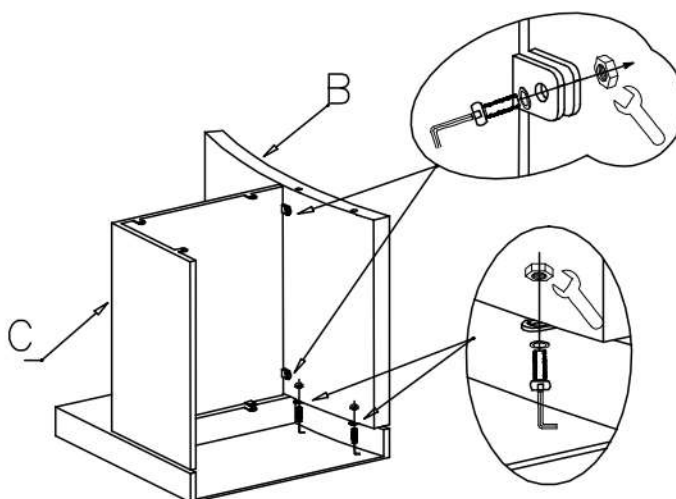

2.

Attach sofa back (B) to sofa base (C) and sofa side (A). Align the bolt brackets of (B) with those of (A) and (C) as shown in the diagram above. For each of the connecting bolt brackets, insert bolt (D) through a washer (E) through the brackets and secure with a nut (F). Loosely tighten with the Allen key (G) and spanner (H) until all the bolts have been put in place. Then go over each bolt and fully tighten.

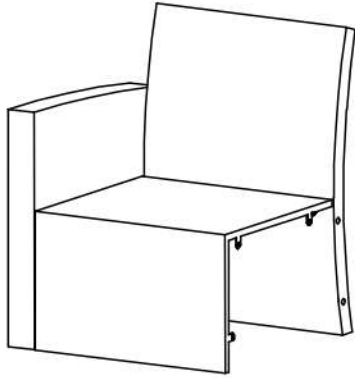

3.

Attach remaining sofa side (A) to the complete the single sofa. Align the bolt brackets with those of (B) and (C). For each of the connecting bolt brackets, insert bolt (D) through a washer (E) through the brackets and secure with a nut (F). Loosely tighten with the Allen key (G) and spanner (H) until all the bolts have been put in place. Then go over each bolt and fully tighten.

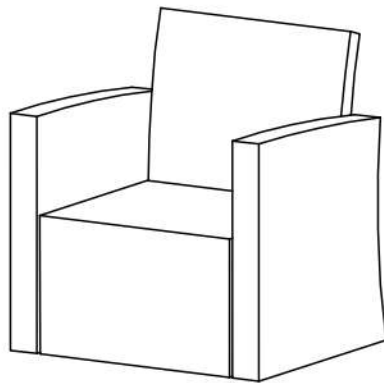

ASSEMBLY INSTRUCTIONS (TABLE)

BEFORE YOU START ASSEMBLING YOUR FURNITURE:

- CHECK THAT YOU HAVE ALL THE PIECES LISTED ON THE LEFT HAND SIDE.
- LAY A CLEAN SHEET ON A FLAT SURFACE BIG ENOUGH TO ASSEMBLE YOUR FURNITURE ON IN ORDER TO PROTECT YOUR FURNITURE.

A	1	
B	2	
C	1	
D	1	
E	6	
F	7	
G	1	
H	1	

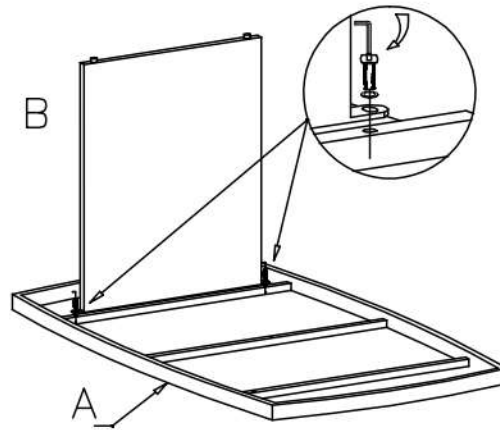

1.

Attach both table legs (B) to the table top (A) – ensuring that the holes in the centre of the table legs face inwards. Align the screw brackets of the table legs (B) with the holes in the base of the table top (A) as demonstrated in the image above. For each bracket insert screw (E) through a washer (F) through the table leg screw bracket and into the table top. Loosely tighten each of the screws using the Allen key (G).

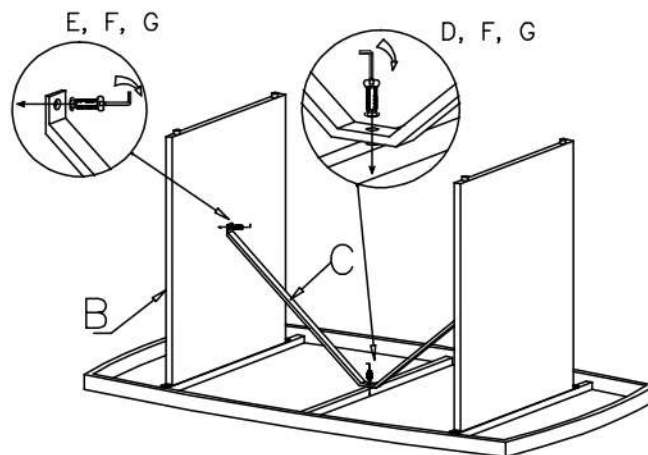

2.

Attach support beam (C) to the table frame. Insert screw (D) through a washer (F) through the hole in the middle of the beam and into the hole in the centre of the table. Loosely tighten with Allen key (G). Then insert screws (E) through a washer, into the screw holes at each side of the beam (C) and into the screw holes in the centre of each table leg. Loosely tighten with Allen key (G).

Fully tighten all of the screws used for the assembly of the table using Allen key (G).

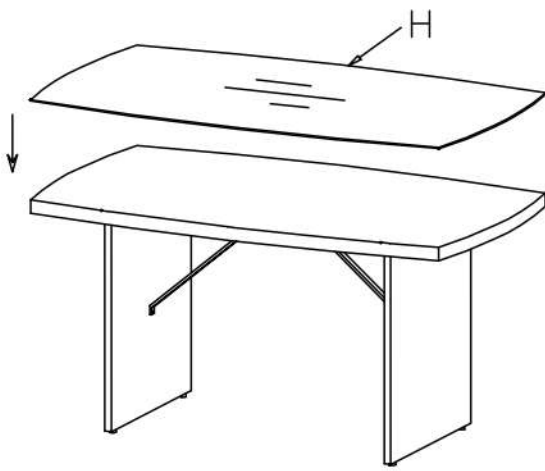

3.

Turn the table frame upright and place the tempered glass (H) over the top as demonstrated in the image to the left.

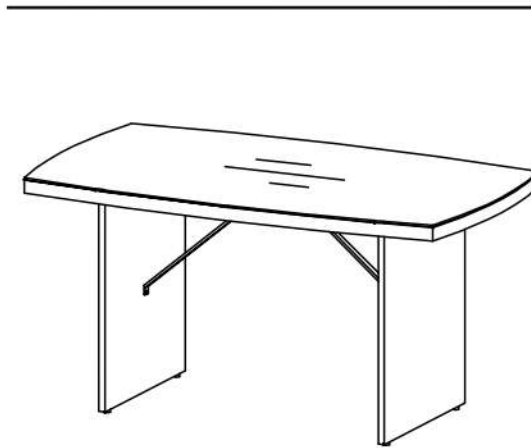

ASSEMBLY INSTRUCTIONS (SIDE TABLE)

BEFORE YOU START ASSEMBLING YOUR FURNITURE:

- CHECK THAT YOU HAVE ALL THE PIECES LISTED ON THE LEFT HAND SIDE.
- LAY A CLEAN SHEET ON A FLAT SURFACE BIG ENOUGH TO ASSEMBLE YOUR FURNITURE ON IN ORDER TO PROTECT YOUR FURNITURE.

A	1	
B1	1	
B2	1	
C1	1	
C2	1	
D	1	
E	18	
F	4	
G	18	
H	1	
I	4	
J	2	

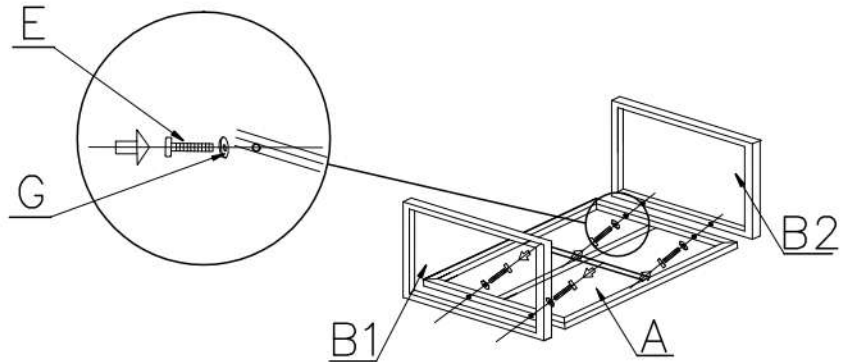

1.

Attach left piece (B1) and right piece (B2) to the bottom plate (A). Align the bolt brackets of A, B1 and B2 in the position shown in the diagram above. For each of the connecting bolt brackets, insert long bolt (E) into the brackets with the Allen key (H). Fully tighten each bolts after all bolts are inserted in the brackets.

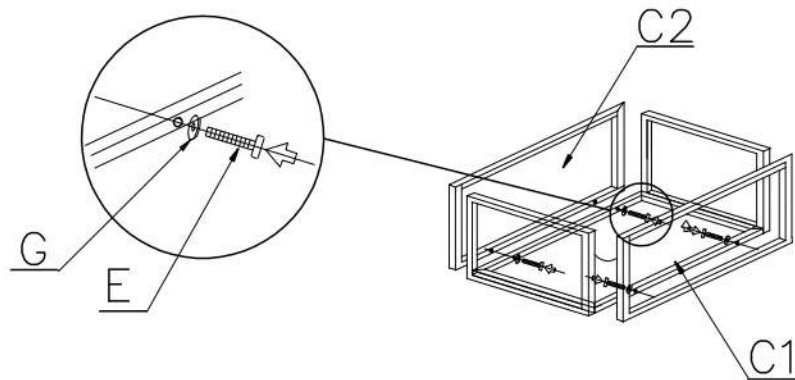

2.

Attach front piece (C1) and back piece (C2) to the bottom plate (A). Align the bolt brackets of A, C1 and C2 in the position shown in the diagram above. For each of the connecting bolt brackets, insert long bolt (E) into the brackets with the Allen key (H). Fully tighten each bolts after all bolts are inserted in the brackets.

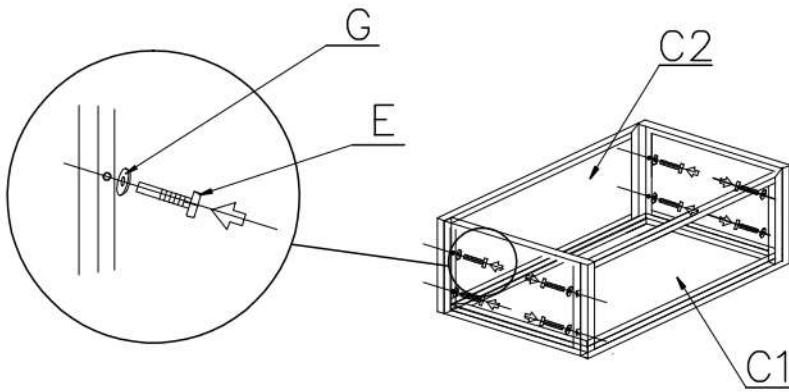

3.

Align the bolt brackets of B1, B2, C1, C2 in the position shown in the diagram above. For each of the connecting bolt brackets, insert long bolt (E) into the brackets with the Allen key (H). Fully tighten each bolts after all bolts are inserted in the brackets.

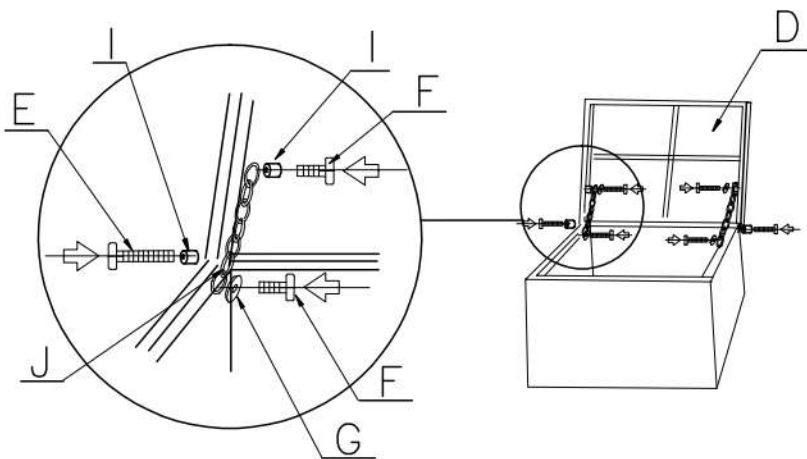

4.

Attach top piece (D) to the back piece (C2). Place the plastic washer (I) in the position shown. Insert long bolt (E) into the brackets with the Allen key (H). Attach the top piece (D) to the left and right plates (B1, B2) with the chain (J). Place the plastic washer (I) and metal washer in the position shown. Insert short bolt (F) into the brackets with the Allen key (H). Fully tighten each bolts after all bolts are inserted in the brackets.

