

ASSEMBLY INSTRUCTIONS

PRE-ASSEMBLY

1. Please read all instructions carefully before beginning assembly.
2. Remove all parts and hardware from the box and lay out on a clean, carpet or scratch-free work surface, as this will avoid damaging any parts during assembly.
3. The shipping box provides an ideal work surface. Do not dispose any contents until assembly is completed to avoid accidentally discarding parts or hardware.
4. We recommend adult assembly by two people for your safety.

PARTS INCLUDED:

1. Head Board-01Pc.
2. Foot Board-01Pc.
3. Side Rail-02Pcs.
4. Center Rail-01Pc.
5. Slats -10 Pcs.

HARDWARE ENCLOSED:

6. Allen Bolts - 08 Pcs.
7. Washers - 08 Pcs.
8. Allen-key - 01 Pc.

Head Board-01 Pc.

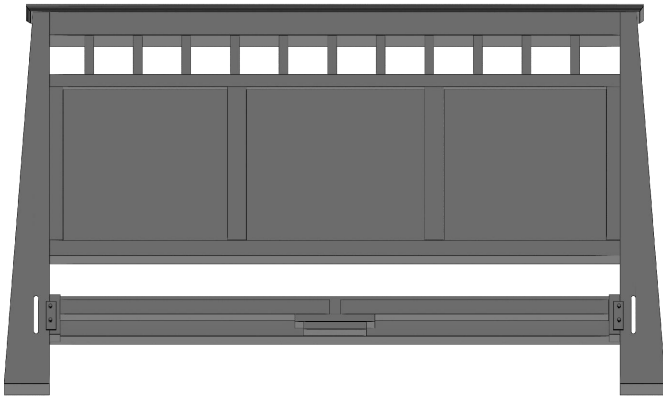

Foot Board-01 Pc.

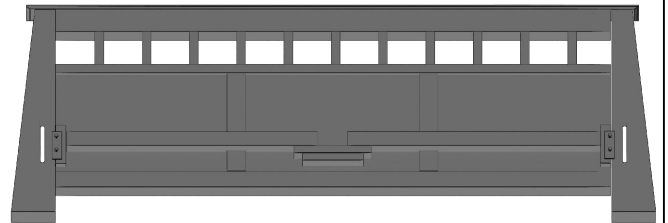

Side Rails-02 Pcs.

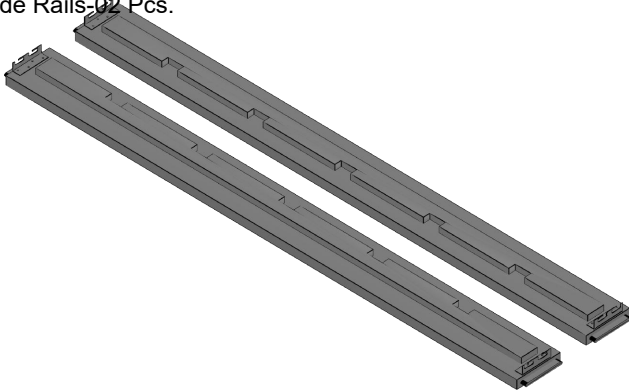

Center Support-01 Pc.

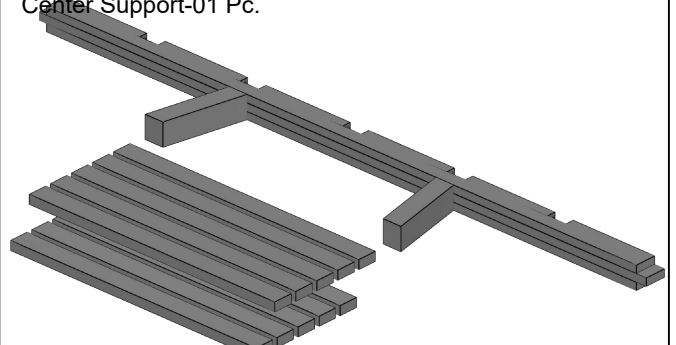

Wooden Slats-10 Pcs.

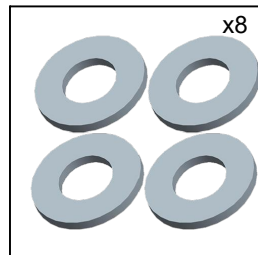
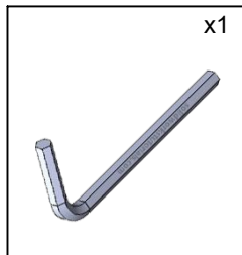

Care Information:

- Clean using a soft, dry cloth.
- Do not use harsh abrasives, chemicals or polishes containing silicone to as they can damage this finish.
- Avoid direct sunlight as this will cause the timber to change colour. • It is important to remove moist substances immediately