

Bed Frame

Asselmbly Instructions

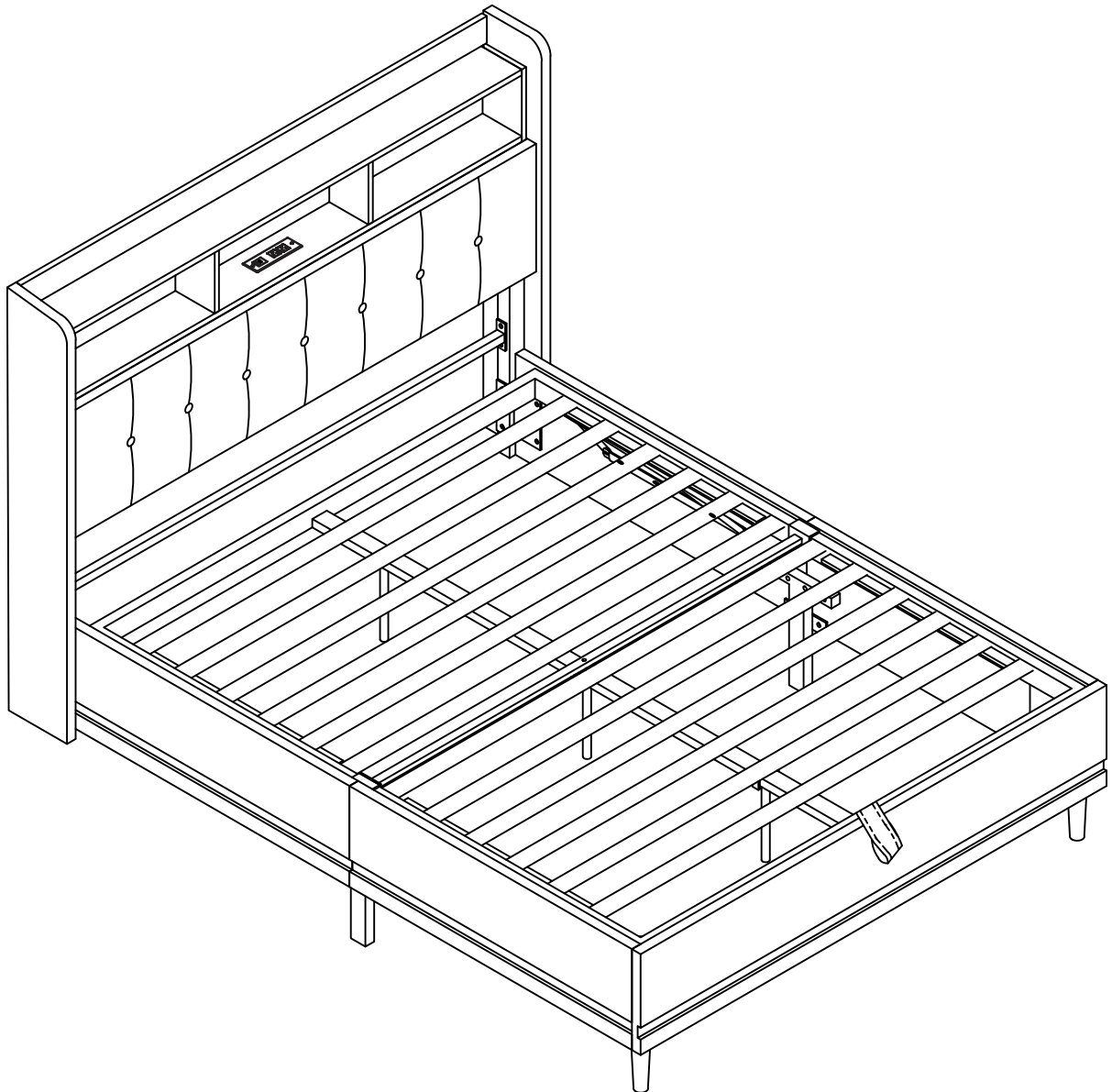

Dear Customers,
Thank you for purchasing our product. Please read this instruction manual carefully after receiving this product. It will help you assemble this product quickly, safely and correctly. You can keep this manual for future reference.
MADE IN CHINA

! IMPORTANT

Please follow the instruction manuals and use a pad to protect the product during your assembly.

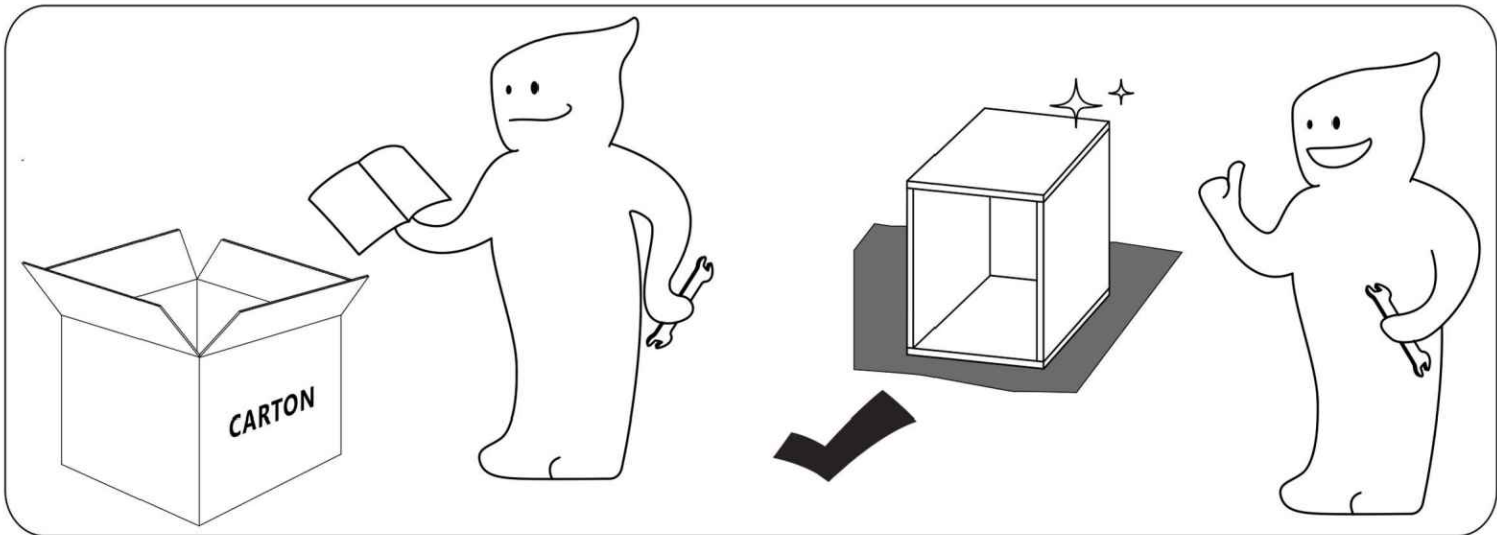
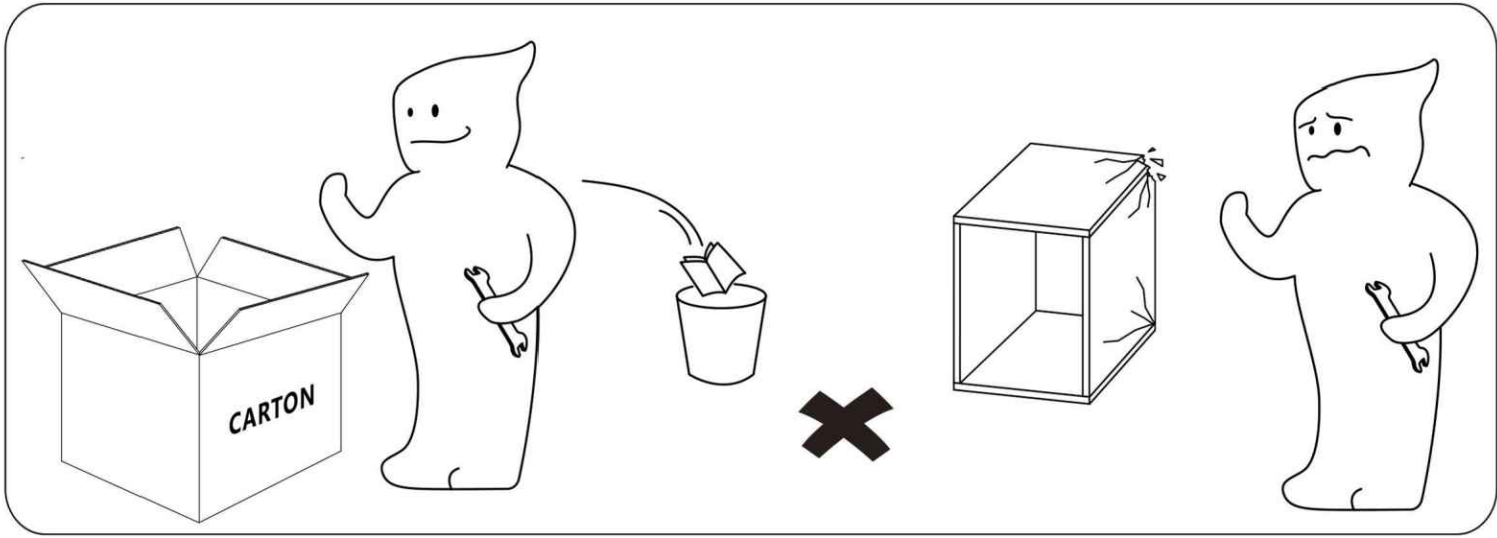

Note:

- 1. Should be assembled on flat ground to keep balance.**
- 2. Before completing the installation, do not tighten the screws.**

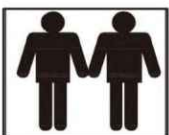

For easier and better assembly, **2** or more adults are required.



Safety and Care Advice

Important-Please read these instructions fully before starting assembly

- Check you have all the components and tools listed on the following pages.
- Remove all fittings from the plastic bags and separate them into their groups.
- Keep children and animals away from the work area, small parts could choke if swallowed.
- Make sure you have enough space to layout the parts before starting.

- During assembly do not stand or put weight on the product, this could cause damage/
- Assemble the item as close to its final position (in the same room) as possible.
- Assemble on a soft level surface to avoid damaging the unit or your floor.
- Parts of the assembly will be easier with 2 people.



power drill is set on a low torque setting .

- To reduce the likelihood of damaging your product please ensure that your

Care and maintenance

- Only clean using a damp cloth and mild detergent, do not use bleach or abrasive cleaners.

- From time to time check that there are no loose screws on this unit.

- This product should not be discarded with household waste. Take to your local authority waste disposal centre.

Handy Hints

- Assemble all parts and bolts loosely during assembly, only once the product is complete should you fully tighten the bolts.

- Regularly check and ensure that all bolts and fittings are tightened properly.

WARNING

In order to help prevent overturning- please follow these instructions



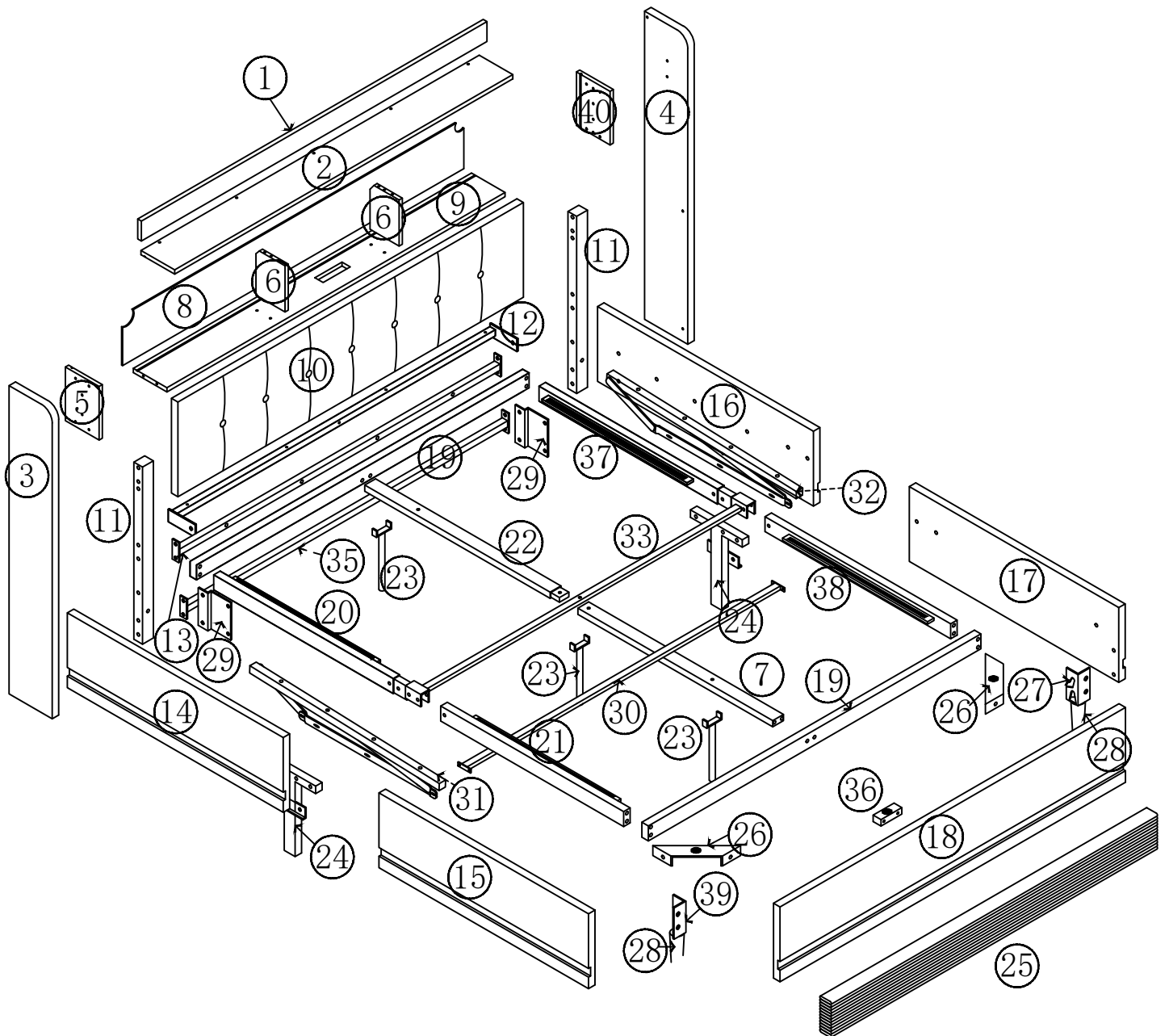

To help prevent product toppling over please follow the steps below:

- Must use the anti tip strap or wall fixing method provided (whichever applies).
- Do not allow children to climb or hang on the furniture.
- Do not place heavy items on top of the furniture, unless the furniture has been designed for this purpose
- Installation shall be carried out exactly according to the instructions-otherwise a safety risk can occur
- In order to prevent falling down this product must be used with the wall attachment device provided

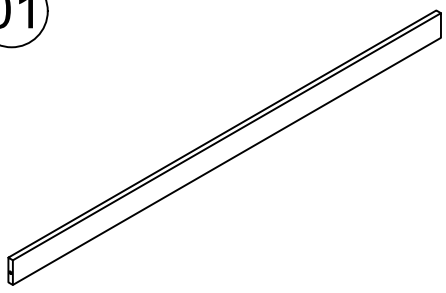
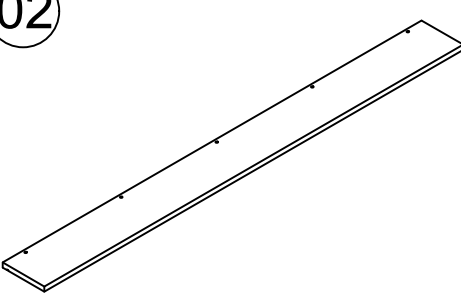
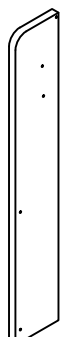
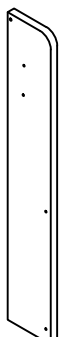
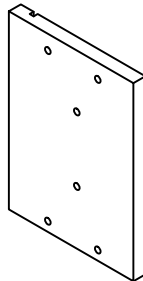
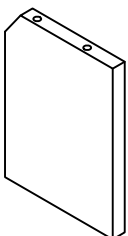
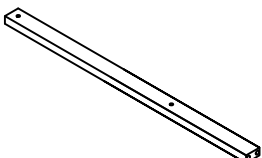
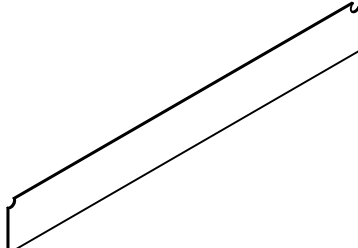
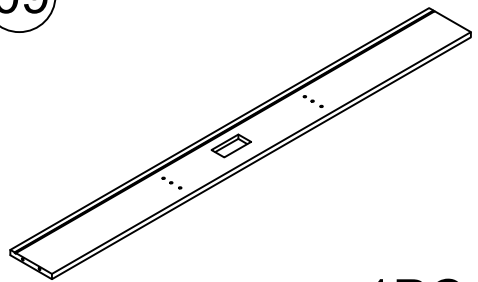
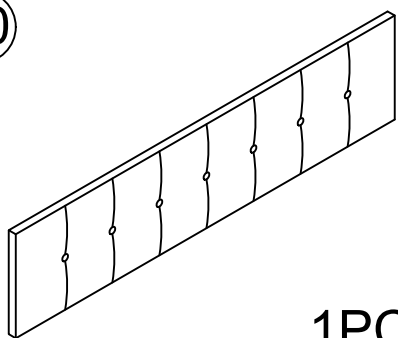
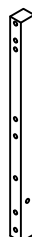
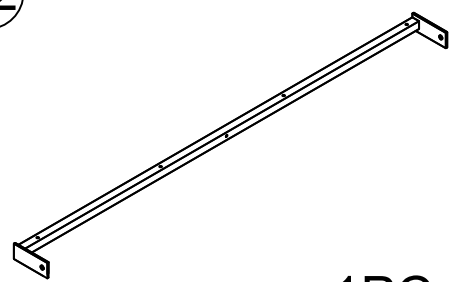
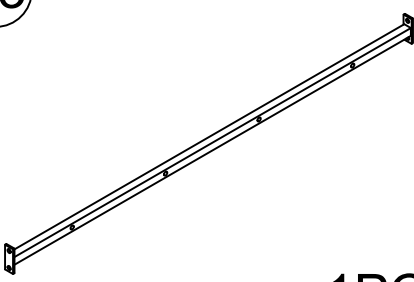
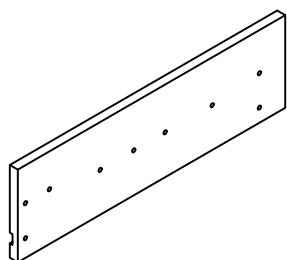
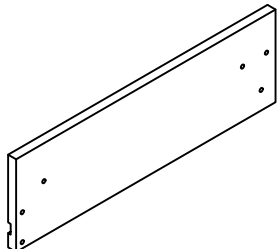
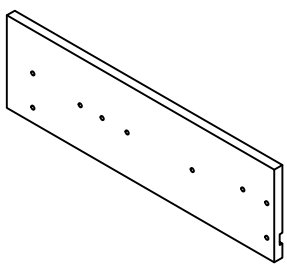
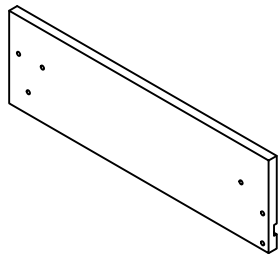
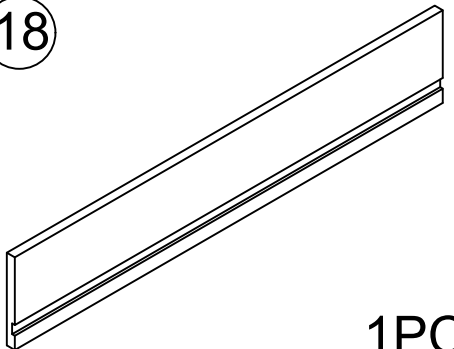
please note that only the wall attachment device is provided. You will need to supply wall plugs and screws applicable for your wall type.

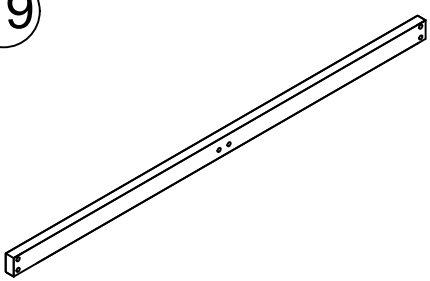
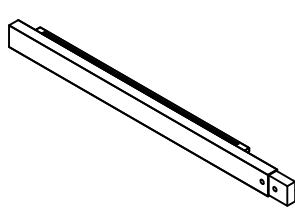
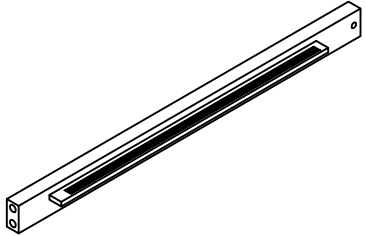
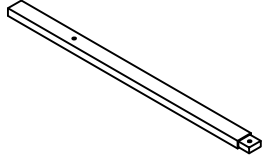
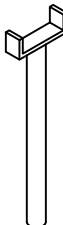
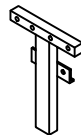
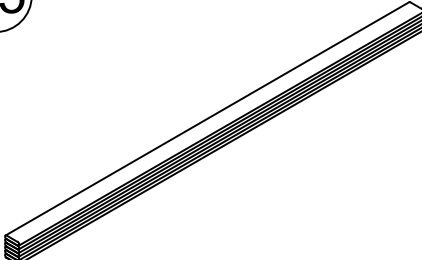

<p>01</p>  <p>1PC</p>	<p>02</p>  <p>1PC</p>	<p>03</p>  <p>1PC</p>
<p>04</p>  <p>1PC</p>	<p>05</p>  <p>1PCS</p>	<p>06</p>  <p>2PCS</p>
<p>07</p>  <p>1PC</p>	<p>08</p>  <p>1PC</p>	<p>09</p>  <p>1PC</p>
<p>10</p>  <p>1PC</p>	<p>11</p>  <p>2PCS</p>	<p>12</p>  <p>1PC</p>
<p>13</p>  <p>1PC</p>	<p>14</p>  <p>1PC</p>	<p>15</p>  <p>1PC</p>
<p>16</p>  <p>1PC</p>	<p>17</p>  <p>1PC</p>	<p>18</p>  <p>1PCS</p>

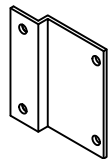
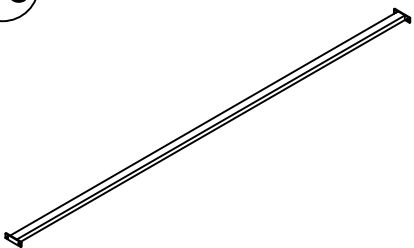
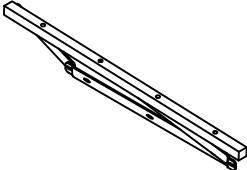
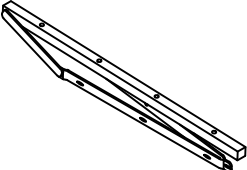
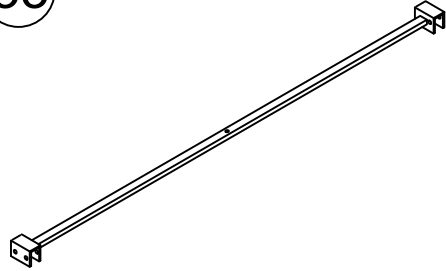
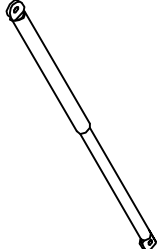
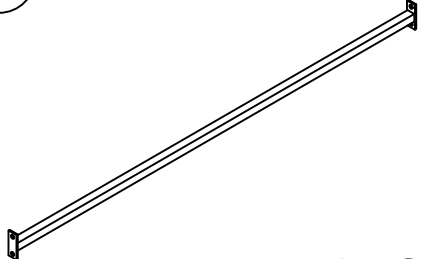
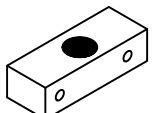
<p>19</p>  <p>2PCS</p>	<p>20</p>  <p>1PC</p>	<p>21</p>  <p>1PC</p>
<p>22</p>  <p>1PC</p>	<p>23</p>  <p>3PCS</p>	<p>24</p>  <p>2PCS</p>
<p>25</p>  <p>2PCS</p>	<p>26</p>  <p>2PCS</p>	<p>27</p>  <p>1PC</p>
<p>28</p>  <p>2PCS</p>	<p>29</p>  <p>2PCS</p>	<p>30</p>  <p>1PC</p>
<p>31</p>  <p>1PC</p>	<p>32</p>  <p>1PC</p>	<p>33</p>  <p>1PC</p>
<p>34</p>  <p>2PCS</p>	<p>35</p>  <p>1PC</p>	<p>36</p>  <p>1PC</p>

37

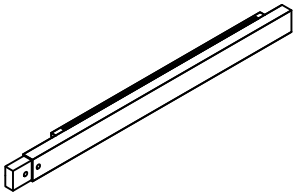

1PC

38

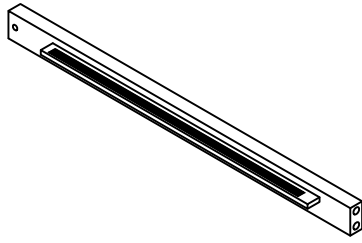

1PC

39

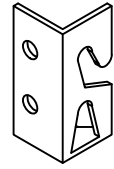



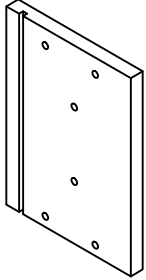

1PC

40

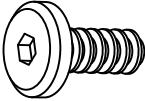
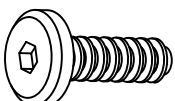
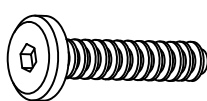
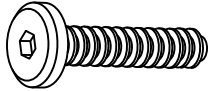
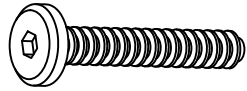
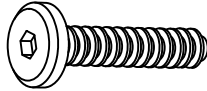
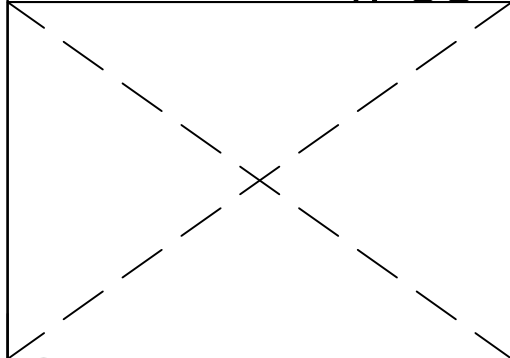
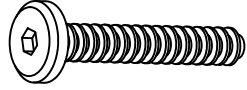
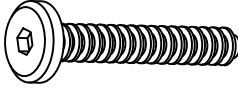

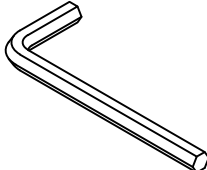
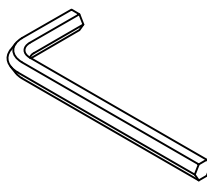
1PC

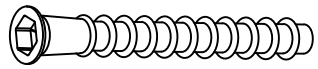
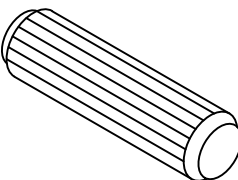
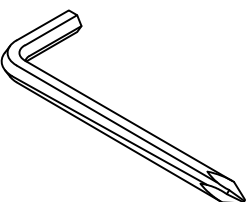
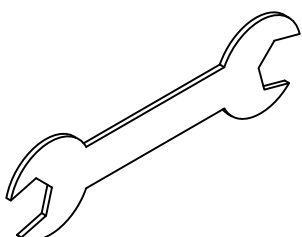
<p>A</p>  <p>M6*20mm 10PCS</p>	<p>B</p>  <p>M6*25mm 1PC</p>	<p>C</p>  <p>M6*35mm 18PCS</p>
<p>D</p>  <p>M6*55mm 1PCS</p>	<p>E</p>  <p>M8*15mm 42PCS</p>	<p>F</p>  <p>M8*30mm 8PCS</p>
	<p>H</p>  <p>M8*40mm 14PCS</p>	<p>I</p>  <p>M8*70mm 4PCS</p>
<p>J</p>  <p>M3.5*15mm 2PCS</p>	<p>K</p>  <p>M4 1PC</p>	<p>L</p>  <p>M3 1PC</p>
<p>M</p>  <p>4PCS</p>	<p>N</p>  <p>4PCS</p>	<p>O</p>  <p>M5*40mm 17PCS</p>
<p>P</p>  <p>Φ8*40mm 2PCS</p>	<p>Q</p>  <p>1PC</p>	<p>R</p>  <p>1PC</p>

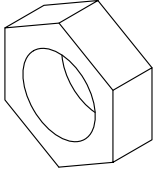
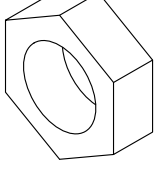
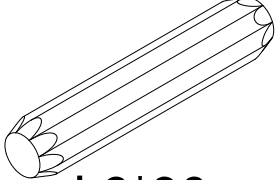
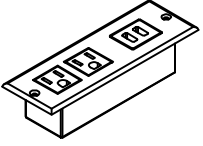
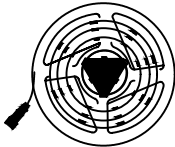
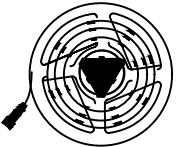
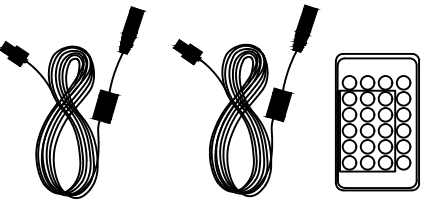
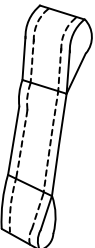
<p>S</p>  <p>M8</p> <p>4PCS</p>	<p>T</p>  <p>M6</p> <p>4PCS</p>	<p>U</p>  <p>$\Phi 6*30\text{mm}$</p> <p>8PCS</p>
<p>V</p>  <p>1PC</p>	<p>W</p>  <p>1.5M</p> <p>1PC</p>	<p>Y</p>  <p>5.5M</p> <p>1PC</p>
<p>Z</p>  <p>1PC</p>	<p>AA</p>  <p>1PC</p>	

Ruler-Use this ruler to help correctly identify the screws.

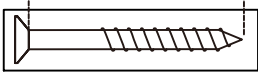

0 5 10 15 20 25 30 35 40 45 50 55 60 65 70 75 80 85 90 95 100 105 110 115 120 125 130 135 140 145 150 155 160 165 170



The length of the screw is measured from the rod part excluding the screw cap (30mm screw shown).

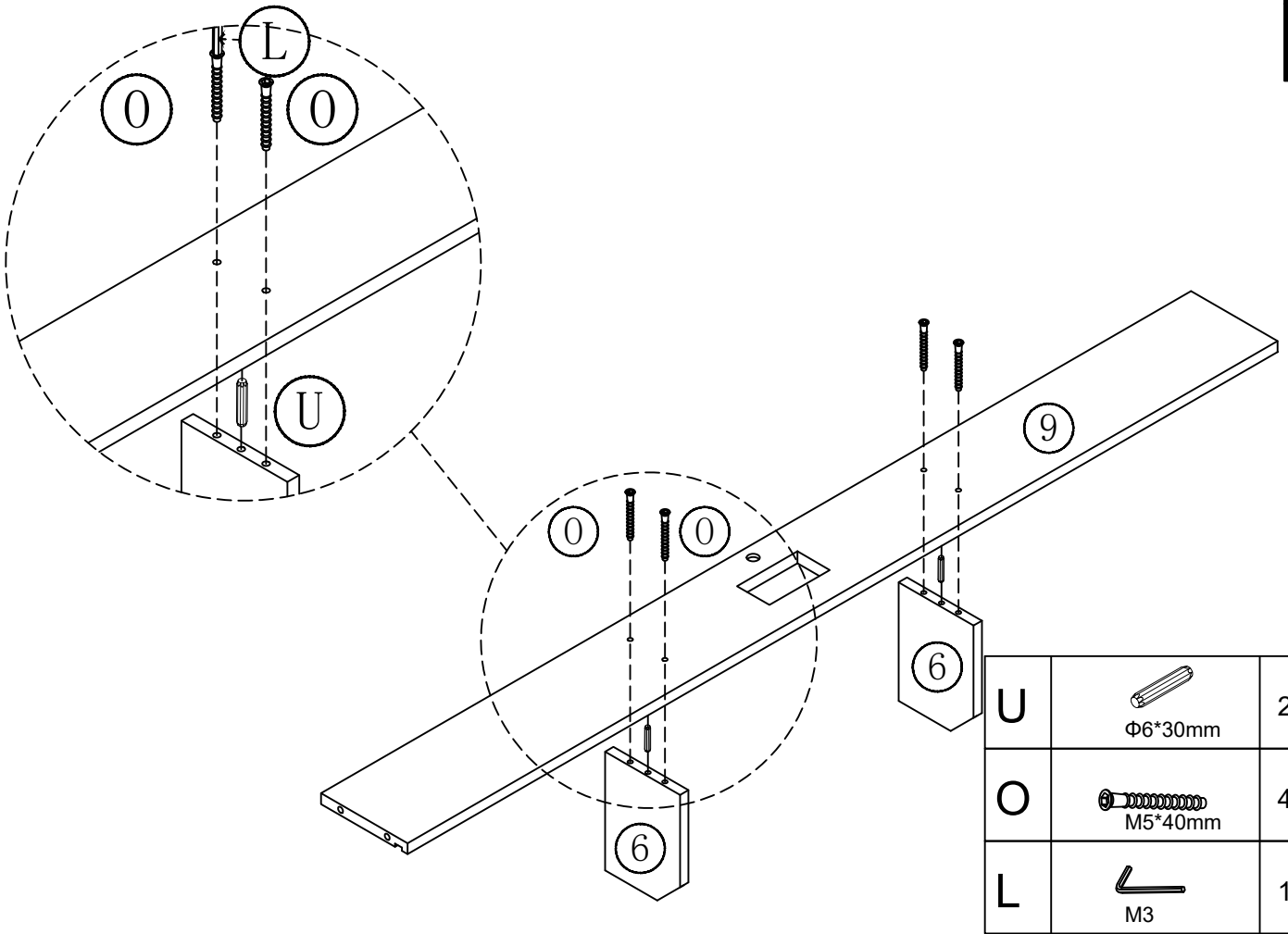

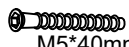
01

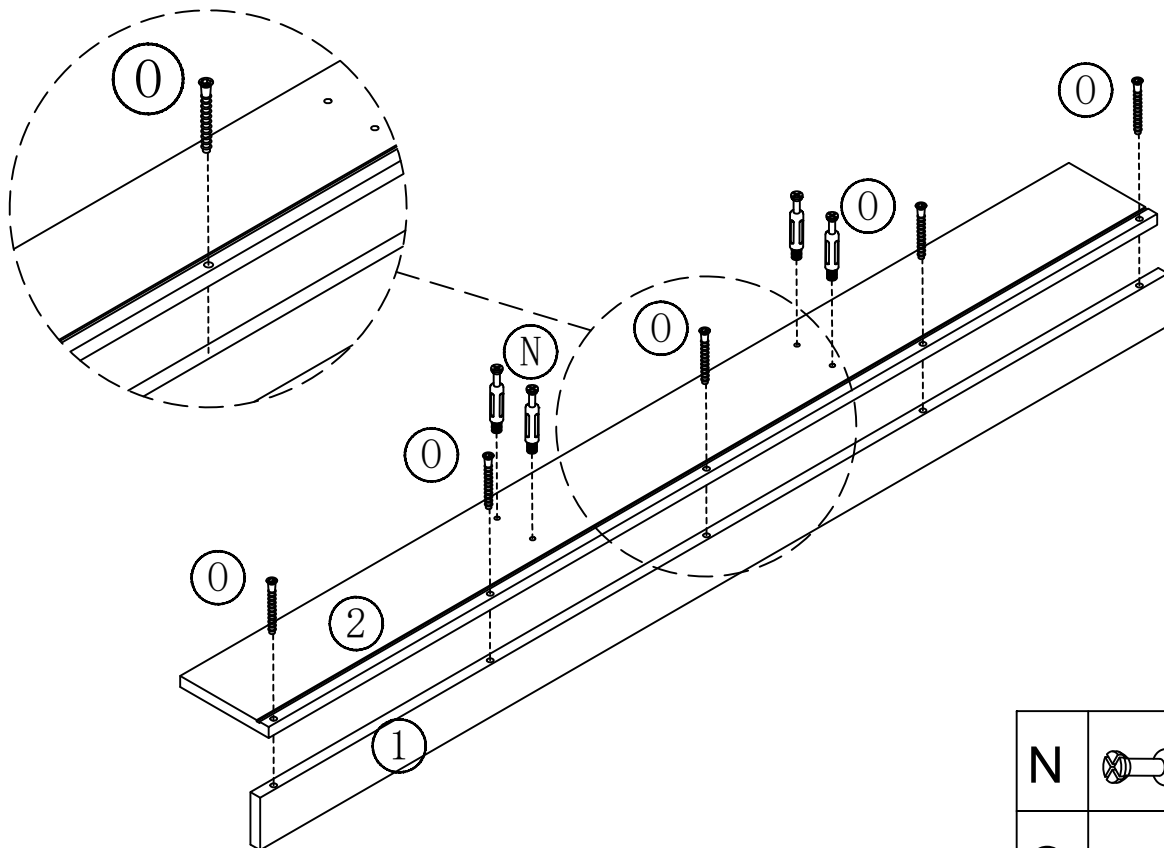

U	 Φ6*30mm	2PCS
O	 M5*40mm	4PCS
L	 M3	1PC

02

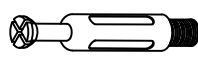
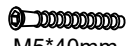



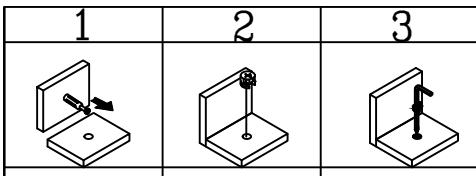

N		4PCS
O	 M5*40mm	5PCS
L	 M3	1PC

03

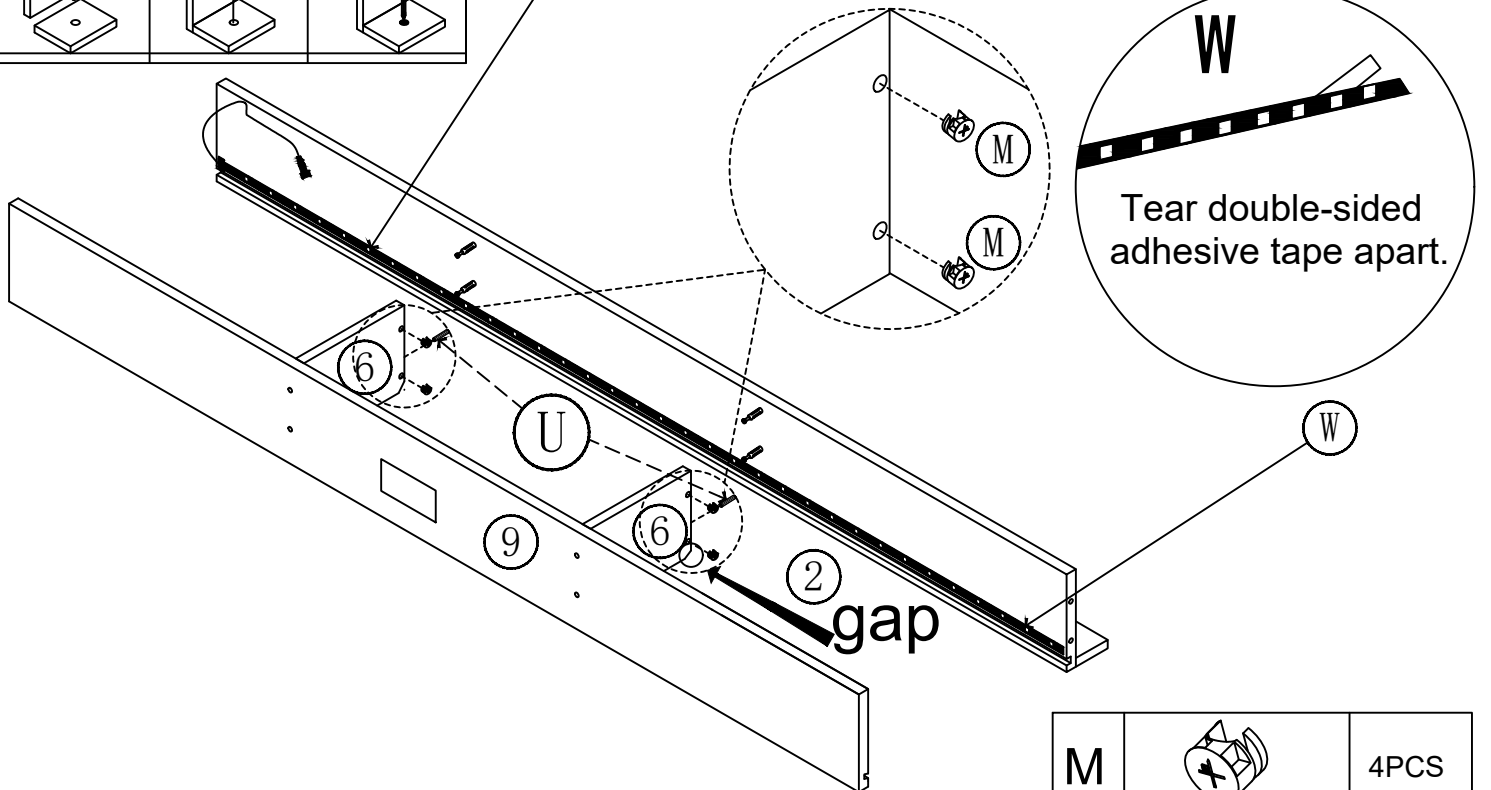



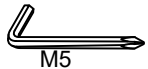

Please first attach the light strip W to part 2, ensuring that the position of light strip W can pass through the gap on part 6.

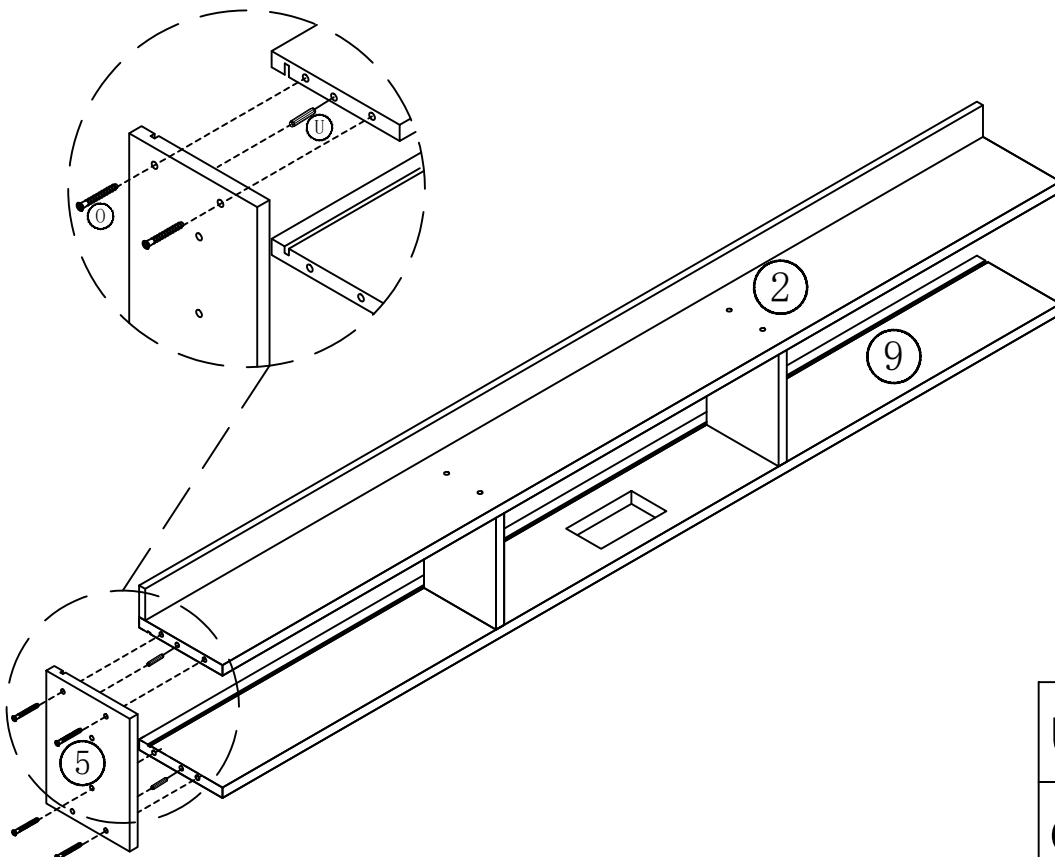

U	 Φ6*30mm	2PCS	W		1PC	M		4PCS
						Q	 M5	1PC

04





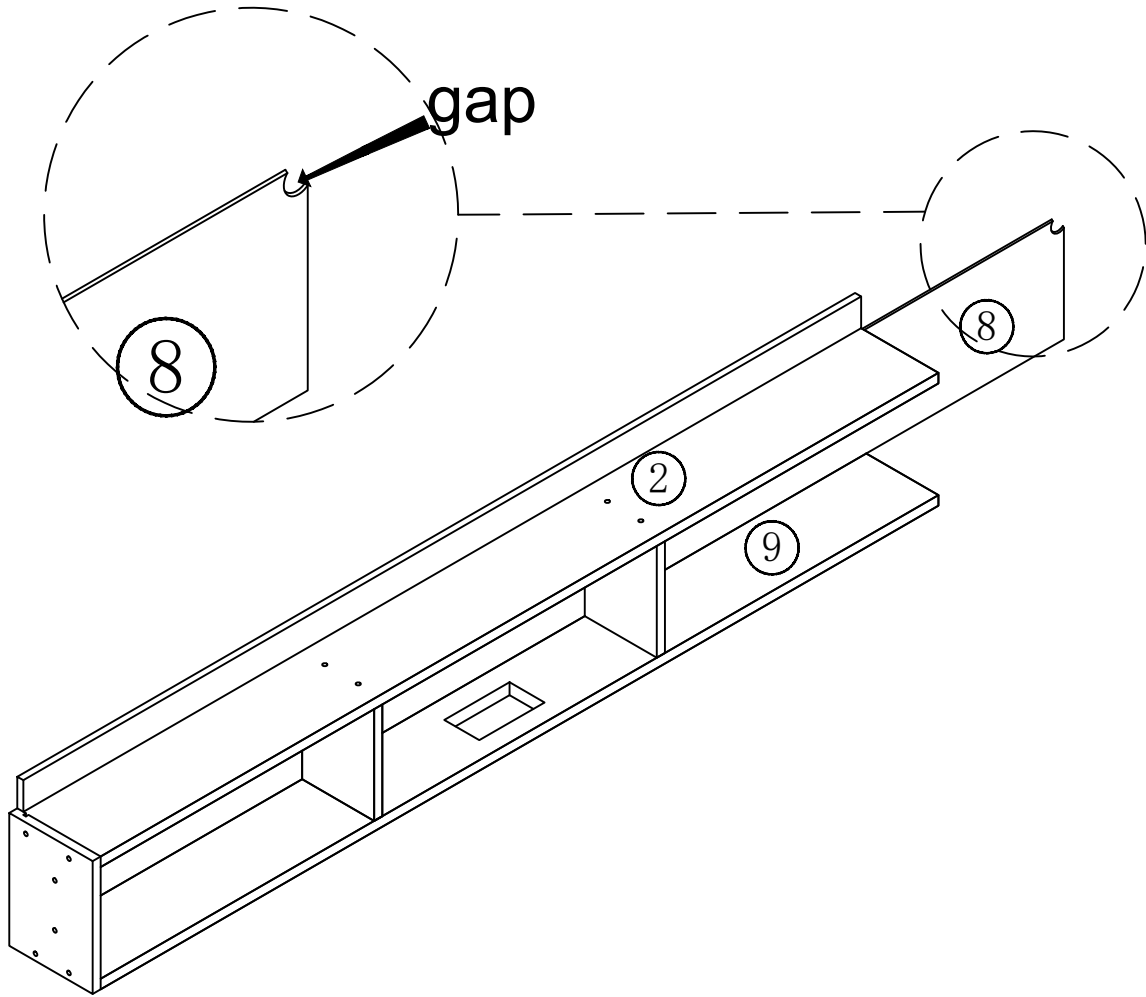

U	 Φ6*30mm	2PCS	O	 M5*40mm	4PCS	L	 M3	1PC
---	--	------	---	--	------	---	---	-----

05

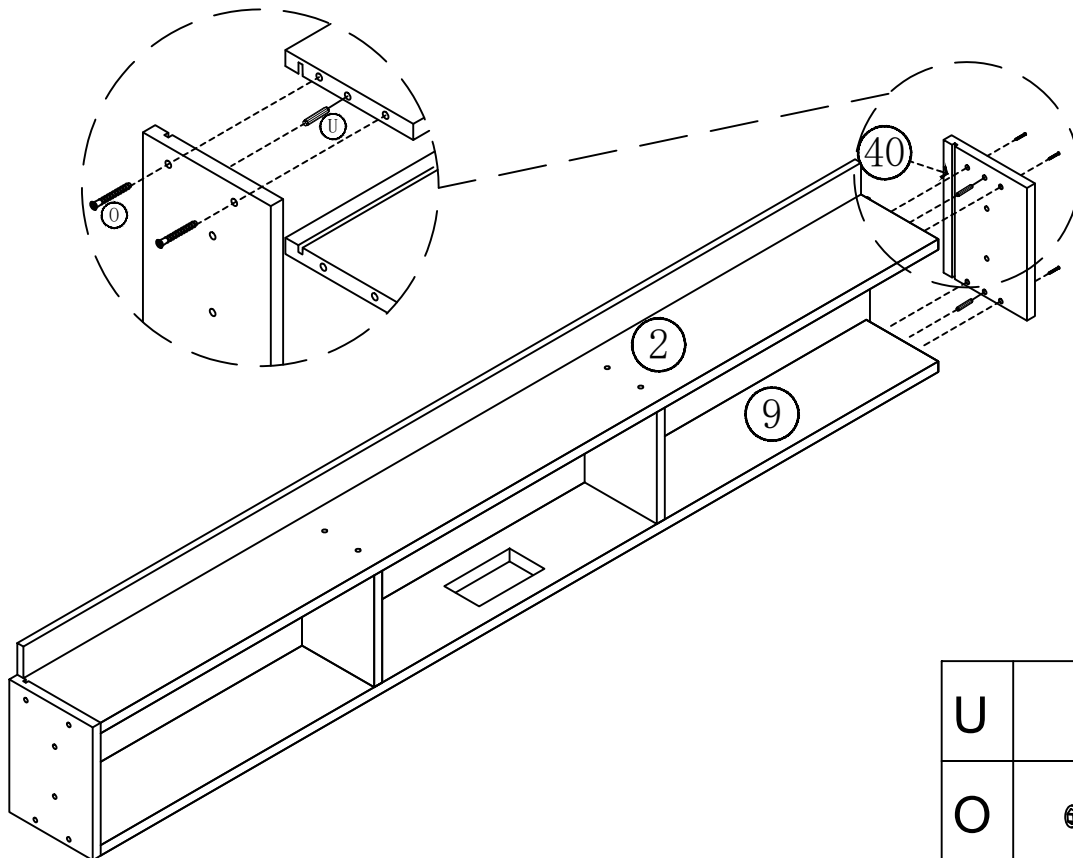



06



U	 Φ6*30mm	2PCS
O	 M5*40mm	4PCS
L	 M3	1PC

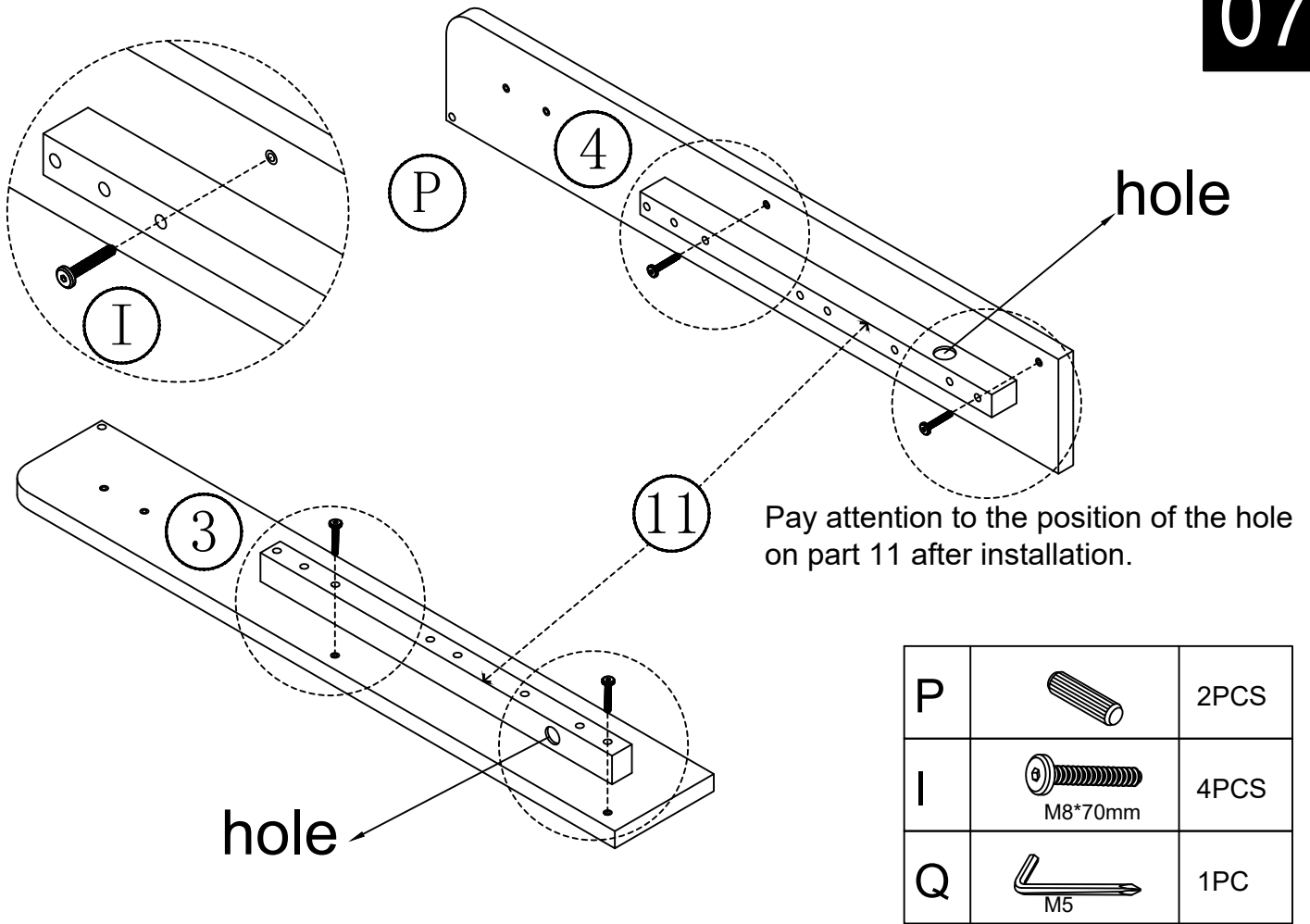

07

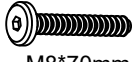
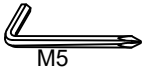

P		2PCS
I	 M8*70mm	4PCS
Q	 M5	1PC

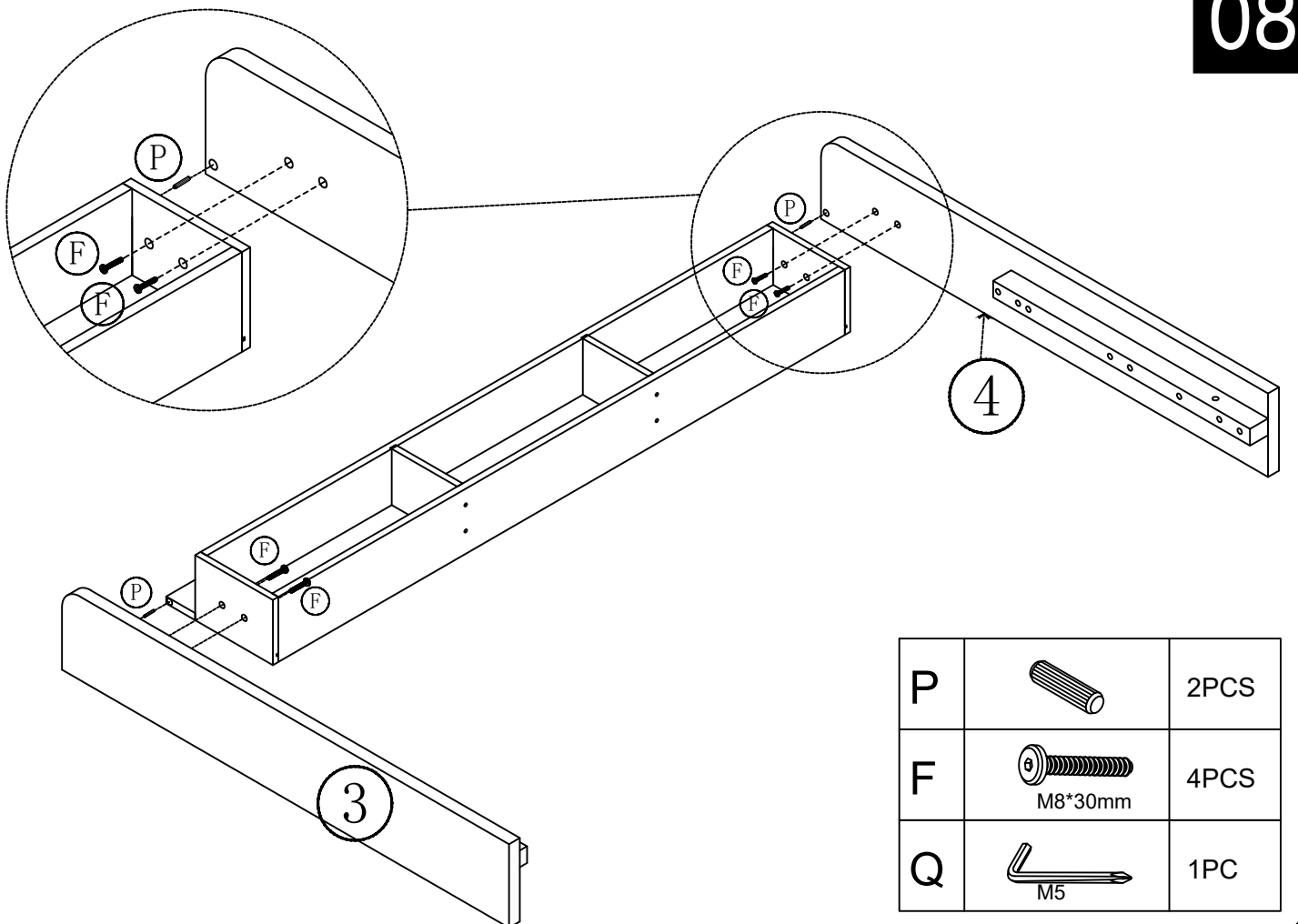
08



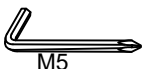

P		2PCS
F	 M8*30mm	4PCS
Q	 M5	1PC

09

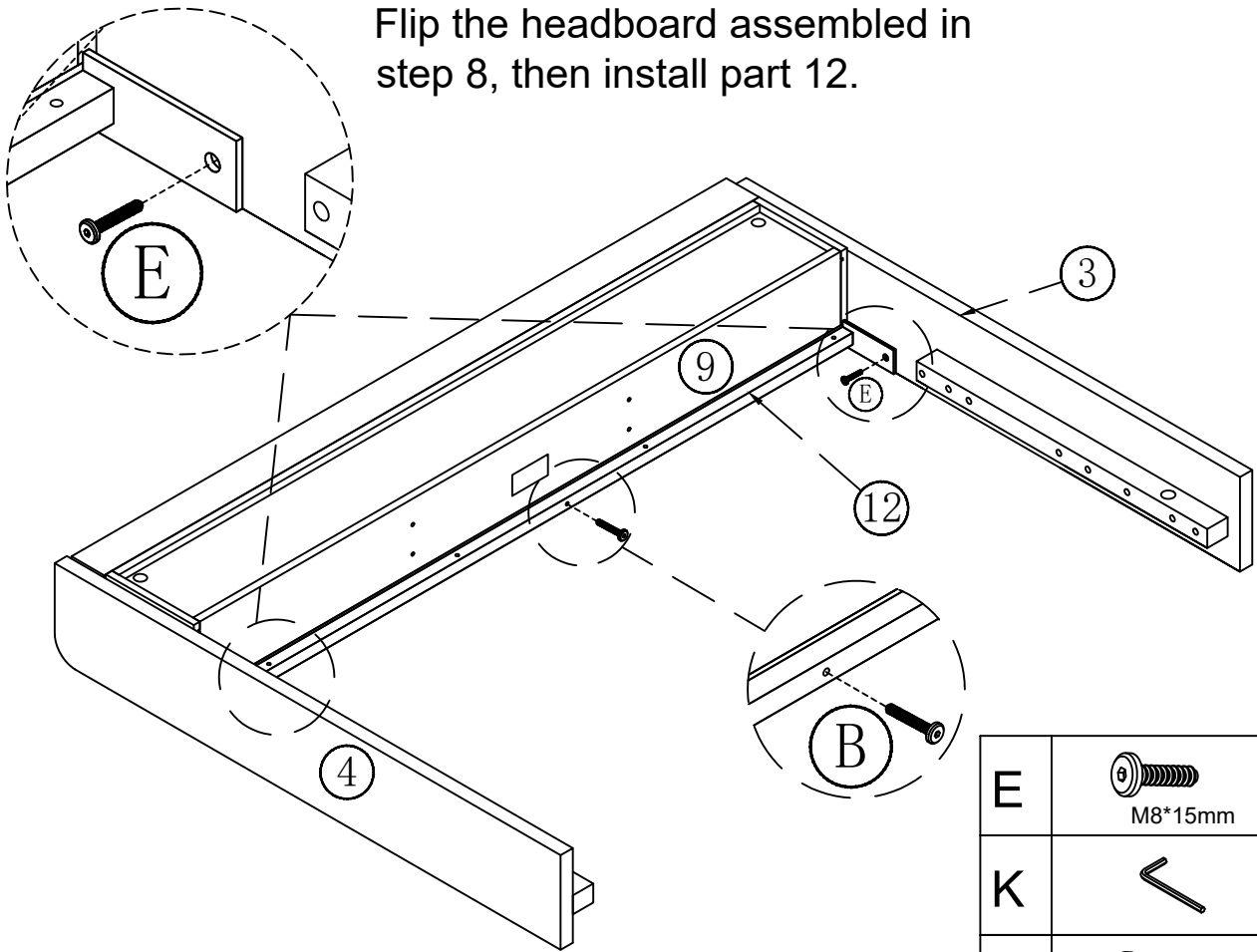

Flip the headboard assembled in step 8, then install part 12.

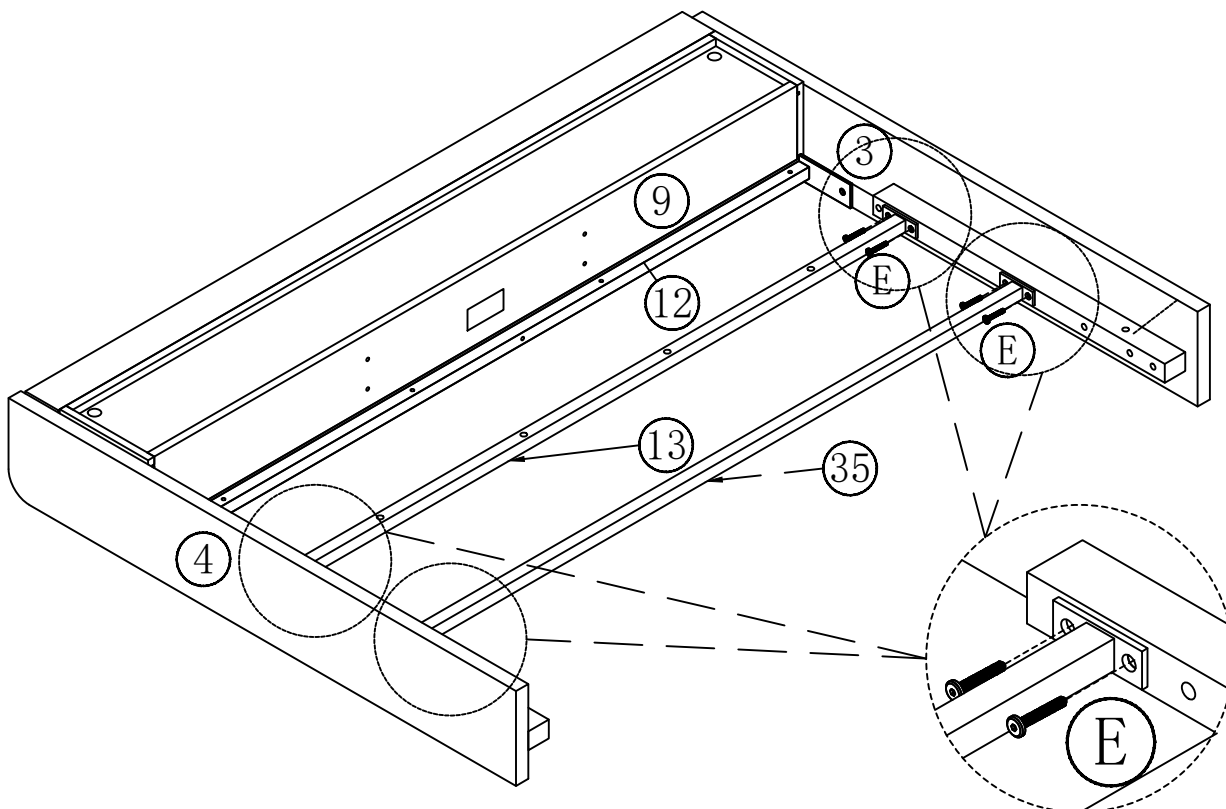

E	 M8*15mm	2PCS
K		1PC
B	 M6*25mm	1PC

10



E	 M8*15mm	8PCS
Q	 M5	1PC

11

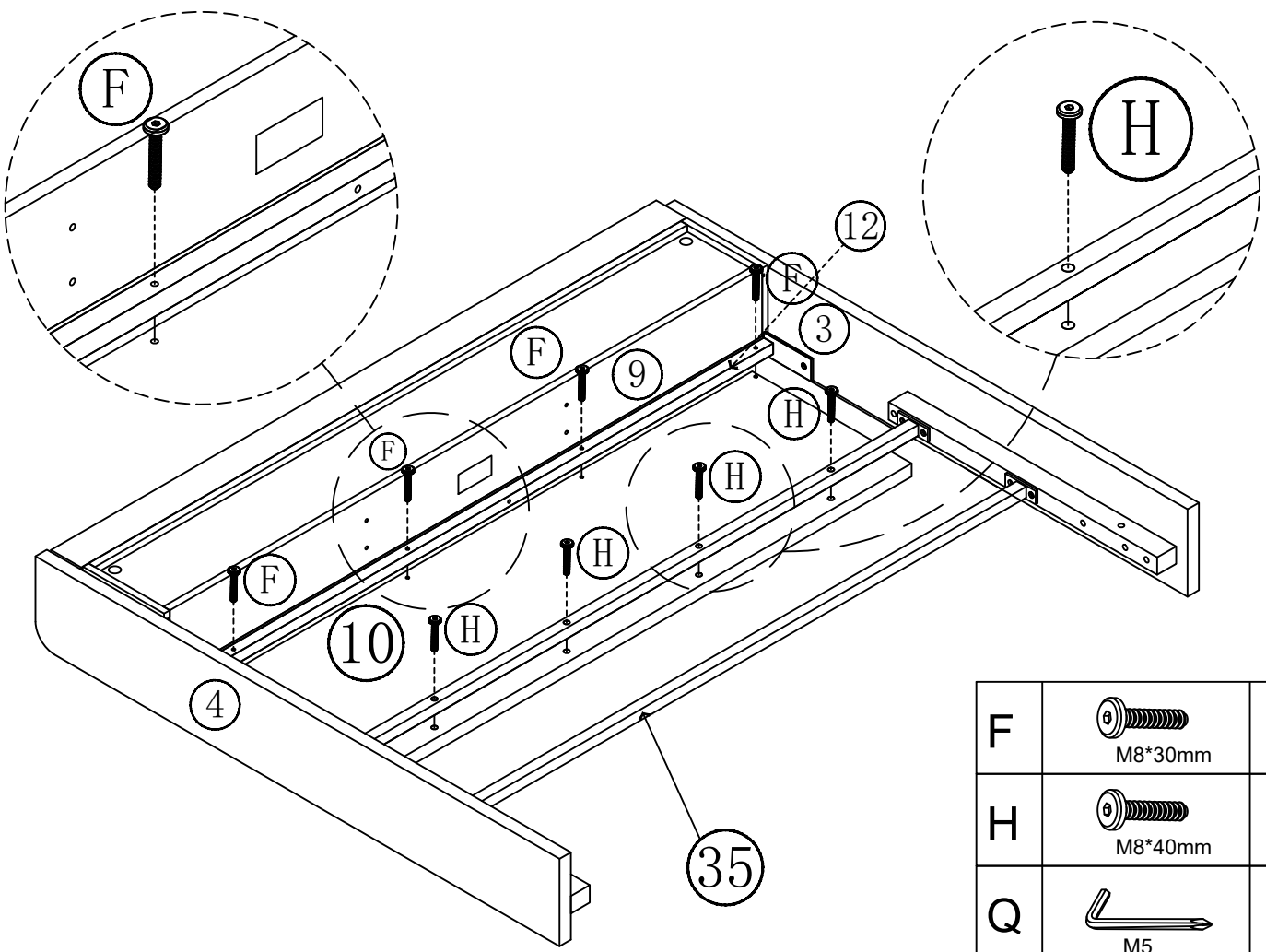

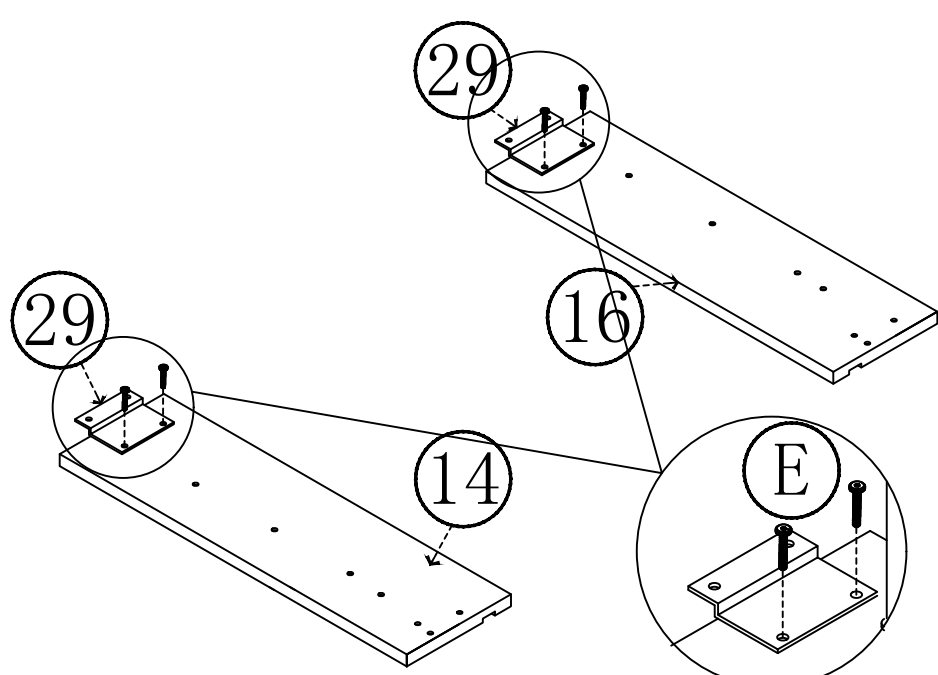

12



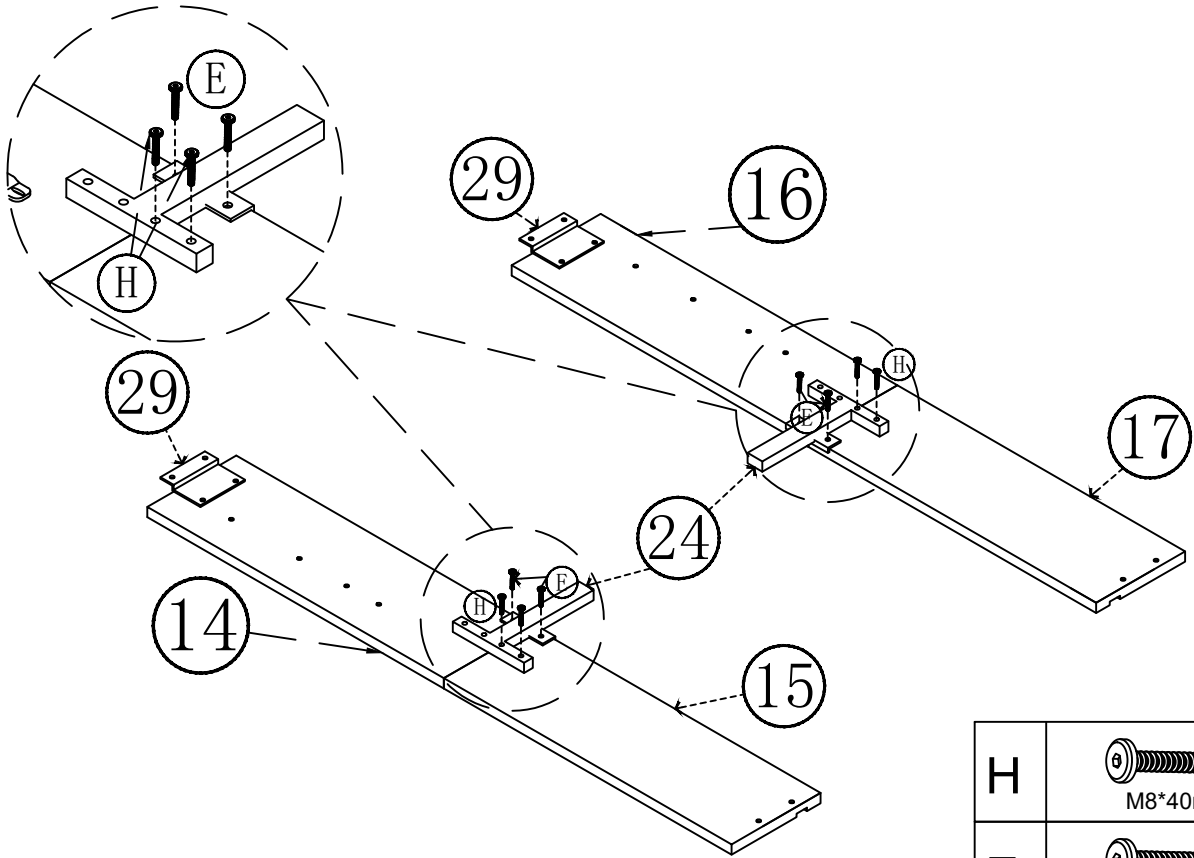

13



H	 M8*40mm	4PCS
E	 M8*15mm	4PCS
Q	 M5	1PC

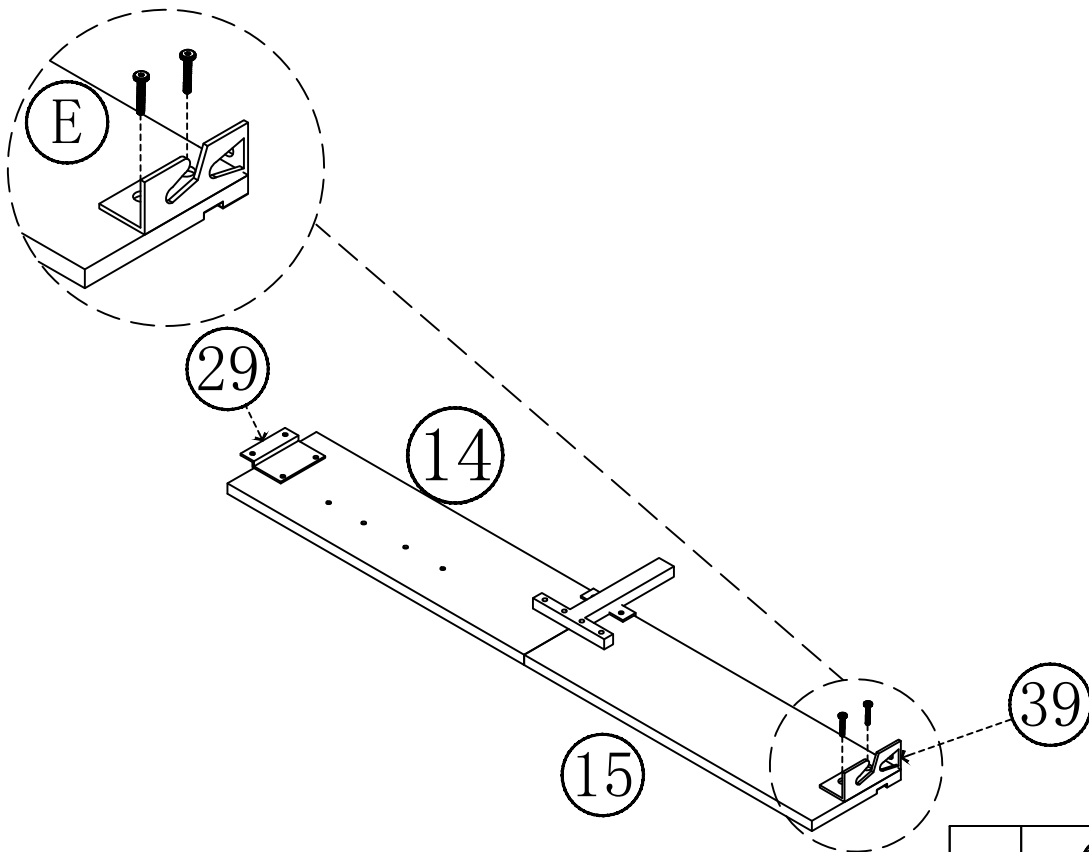

14

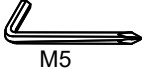

E	 M8*15mm	2PCS
Q	 M5	1PC

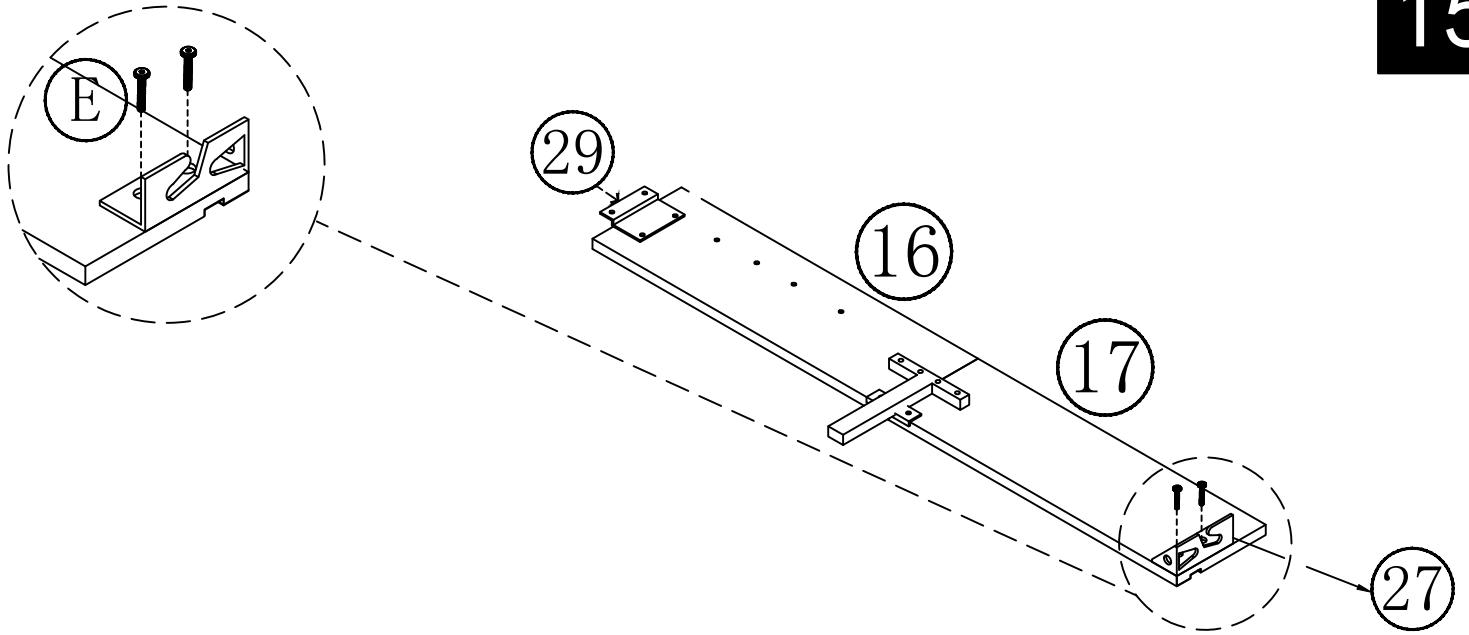

15

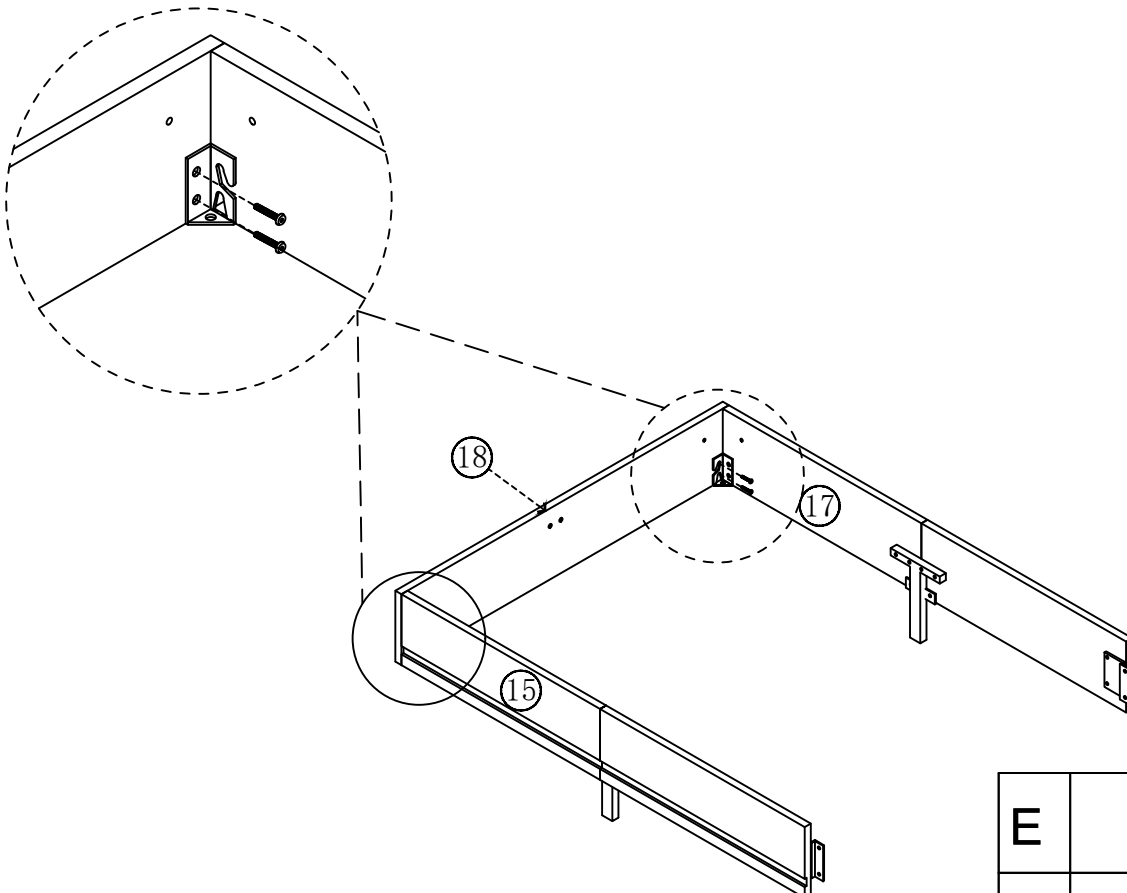

E	 M8*15mm	2PCS
Q		1PC

16



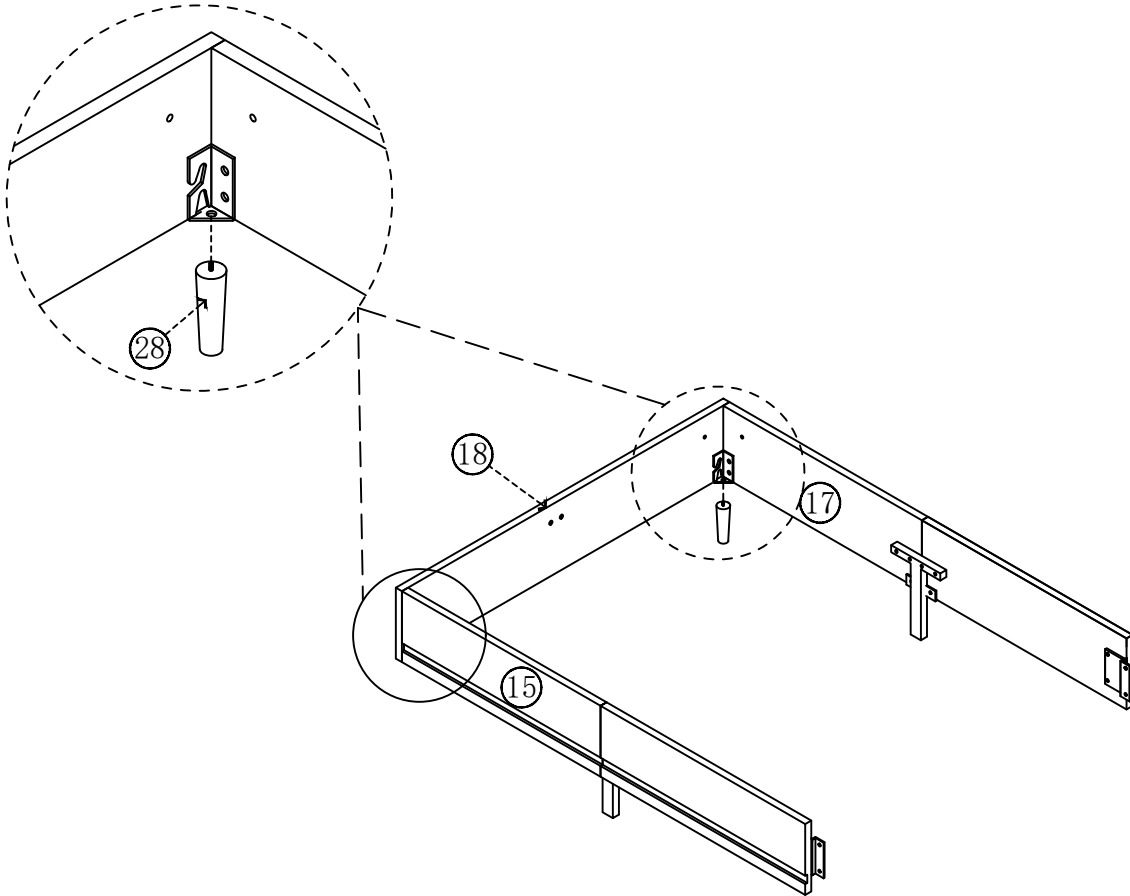

E	 M8*15mm	4PCS
Q		1PC



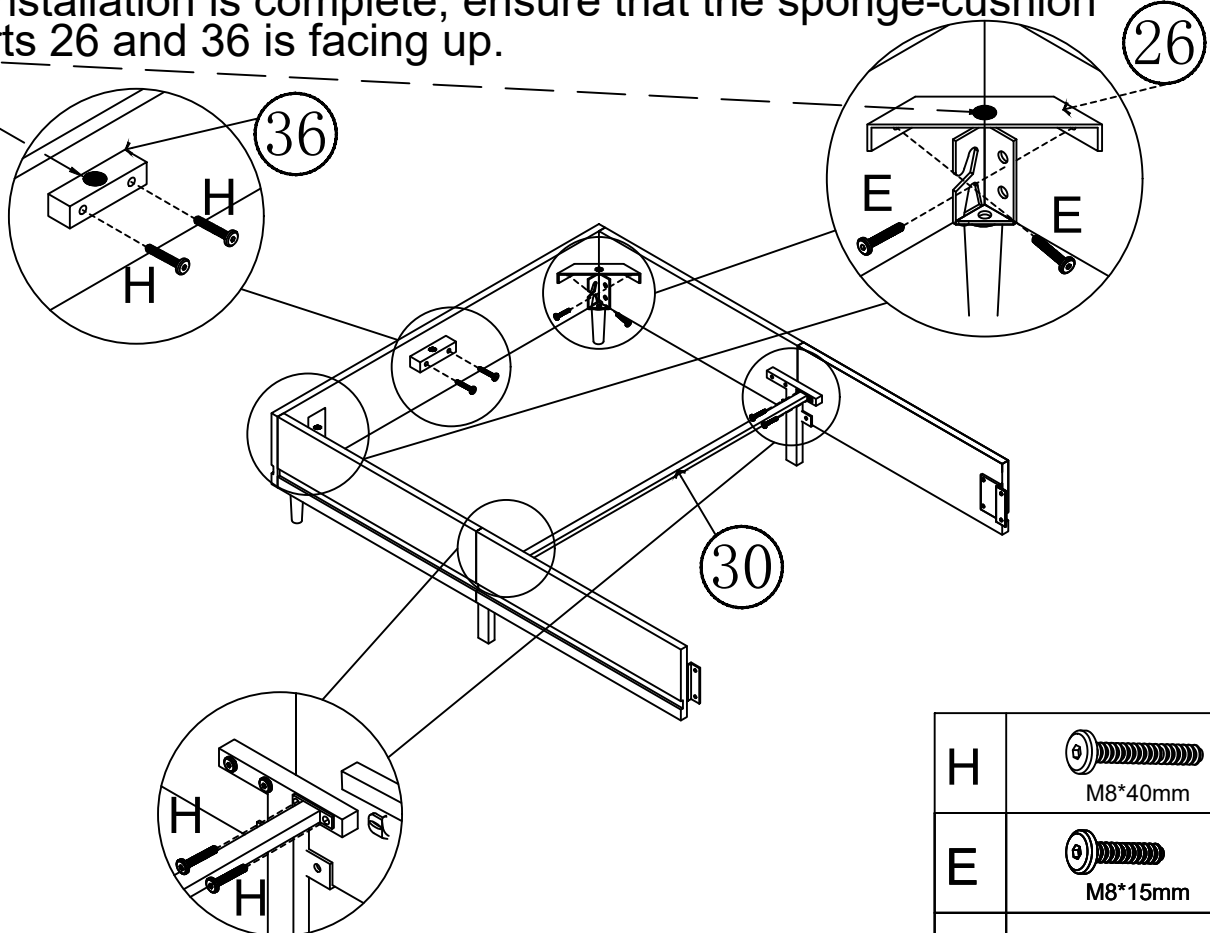

After installation is complete, ensure that the sponge-cushion on parts 26 and 36 is facing up.



In this step, loosen the middle foot bolt first, then align the holes and tighten them all.

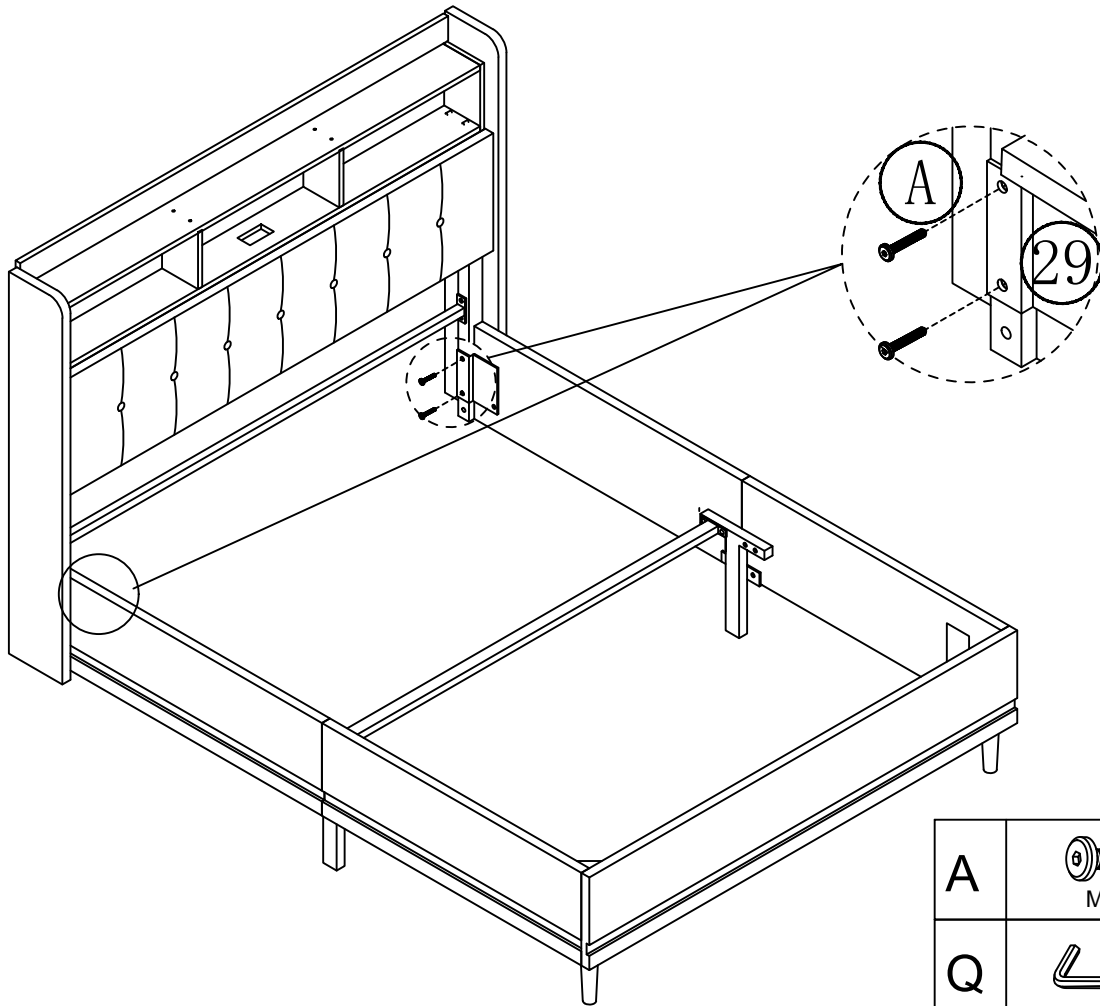

H	 M8*40mm	6PCS
E	 M8*15mm	4PCS
Q	 M5	1PC

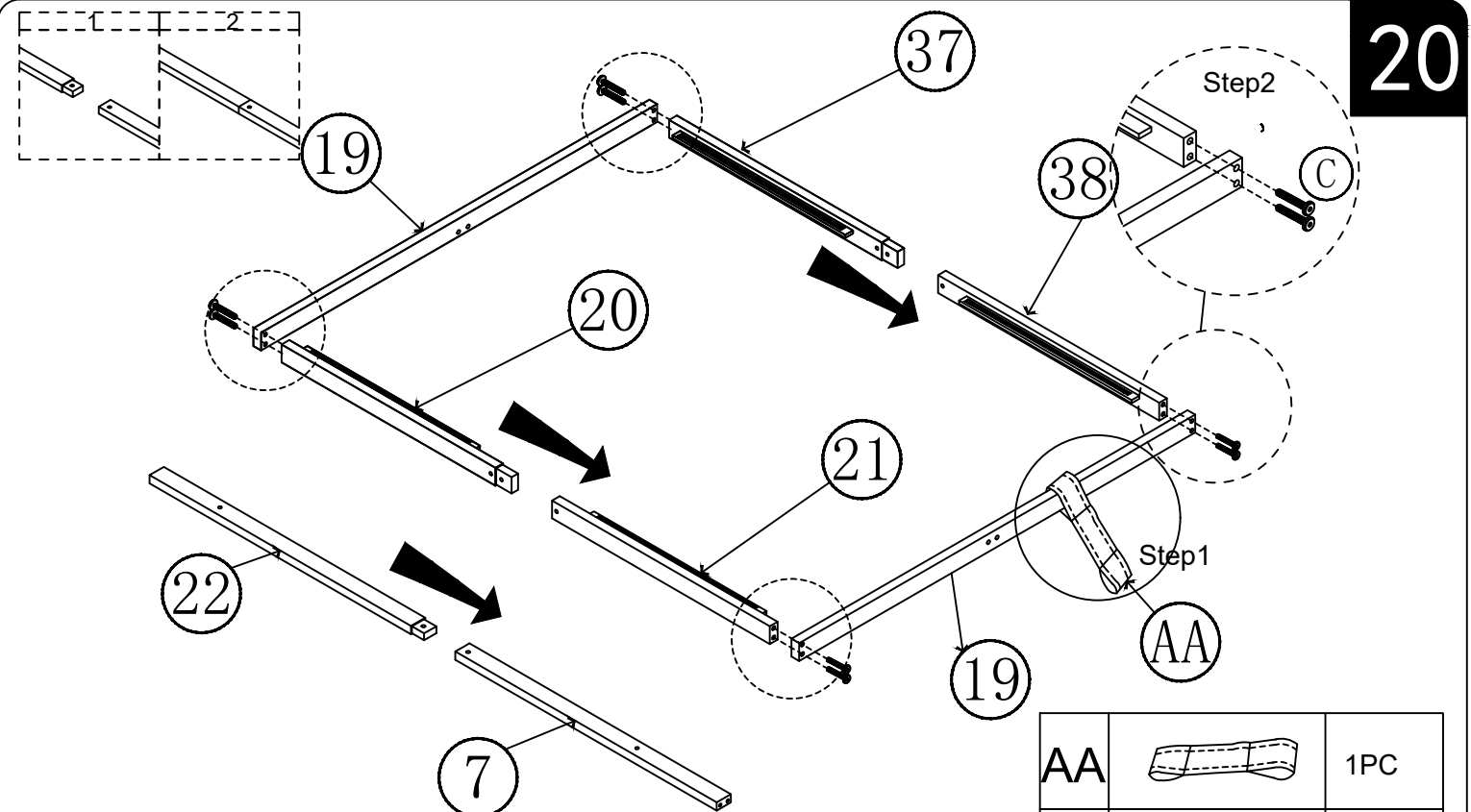

A	 M8*15mm	4PCS
Q	 M5	1PC





Place part AA onto part 19 before installation.
After completing the installation, ensure that the Nylon Fastener on parts 20, 21, 37, and 38 faces upward.

AA		1PC
C	 M6*35mm	8PCS
K	 M4	1PC

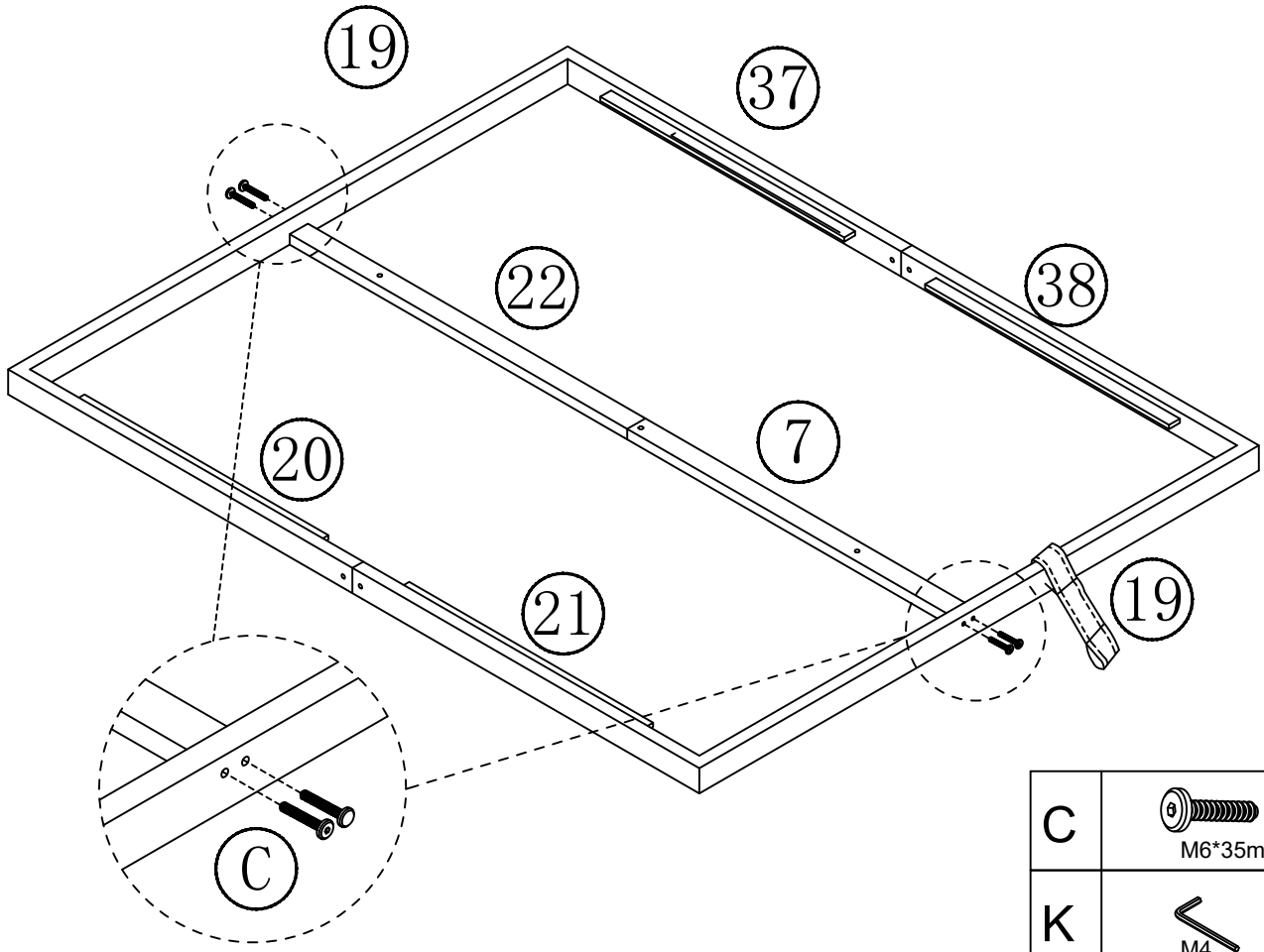



21

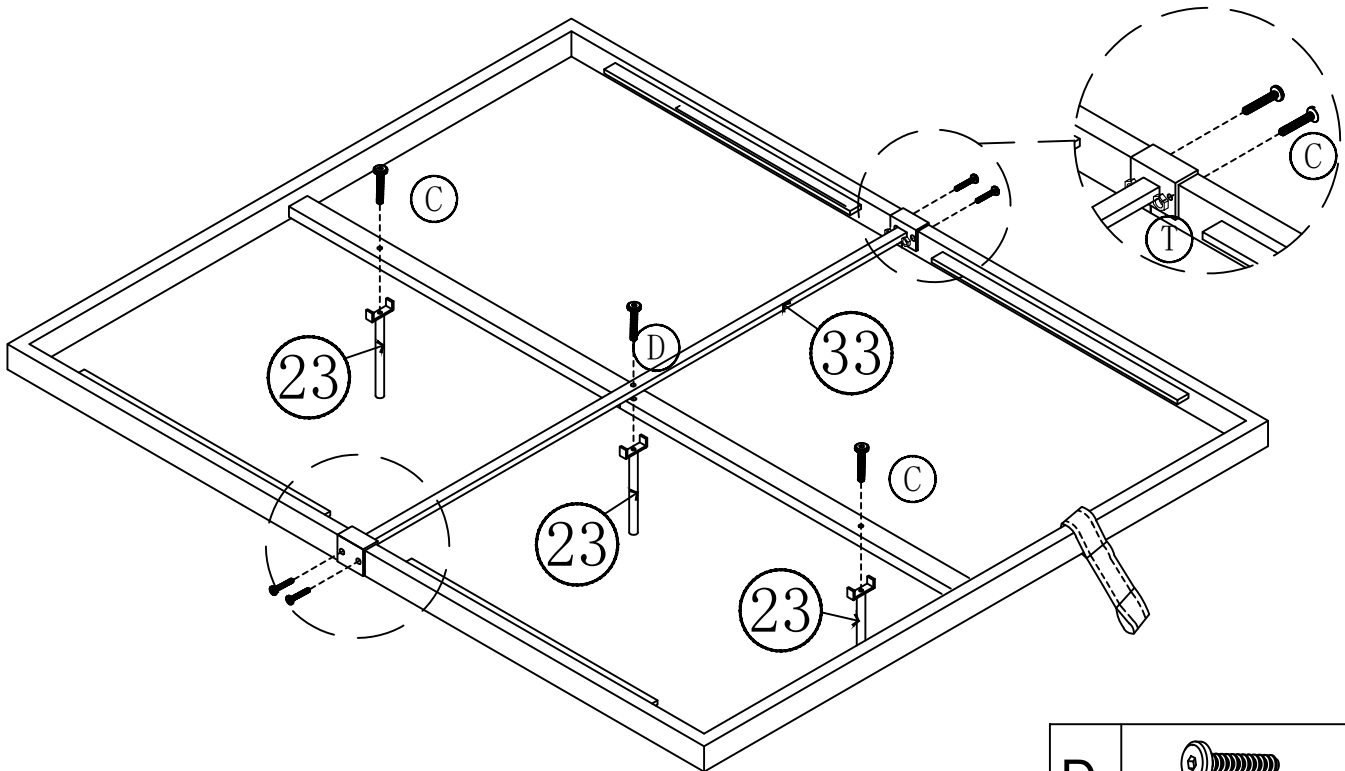

C	 M6*35mm	4PCS
K	 M4	1PC



22



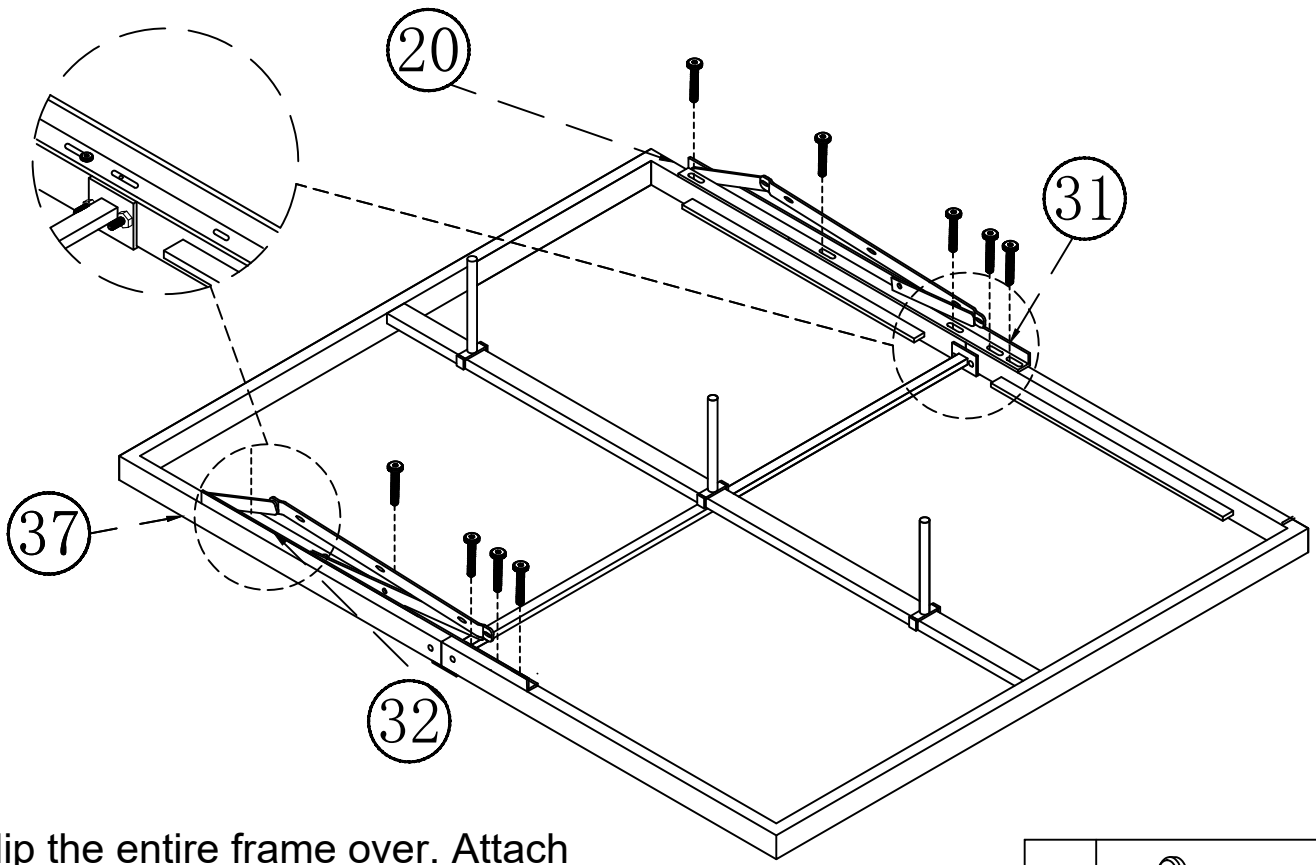

D	 M6*55mm	1PC
R		1PC
T	 M6	4PCS
C	 M6*35mm	6PCS
K	 M4	1PC

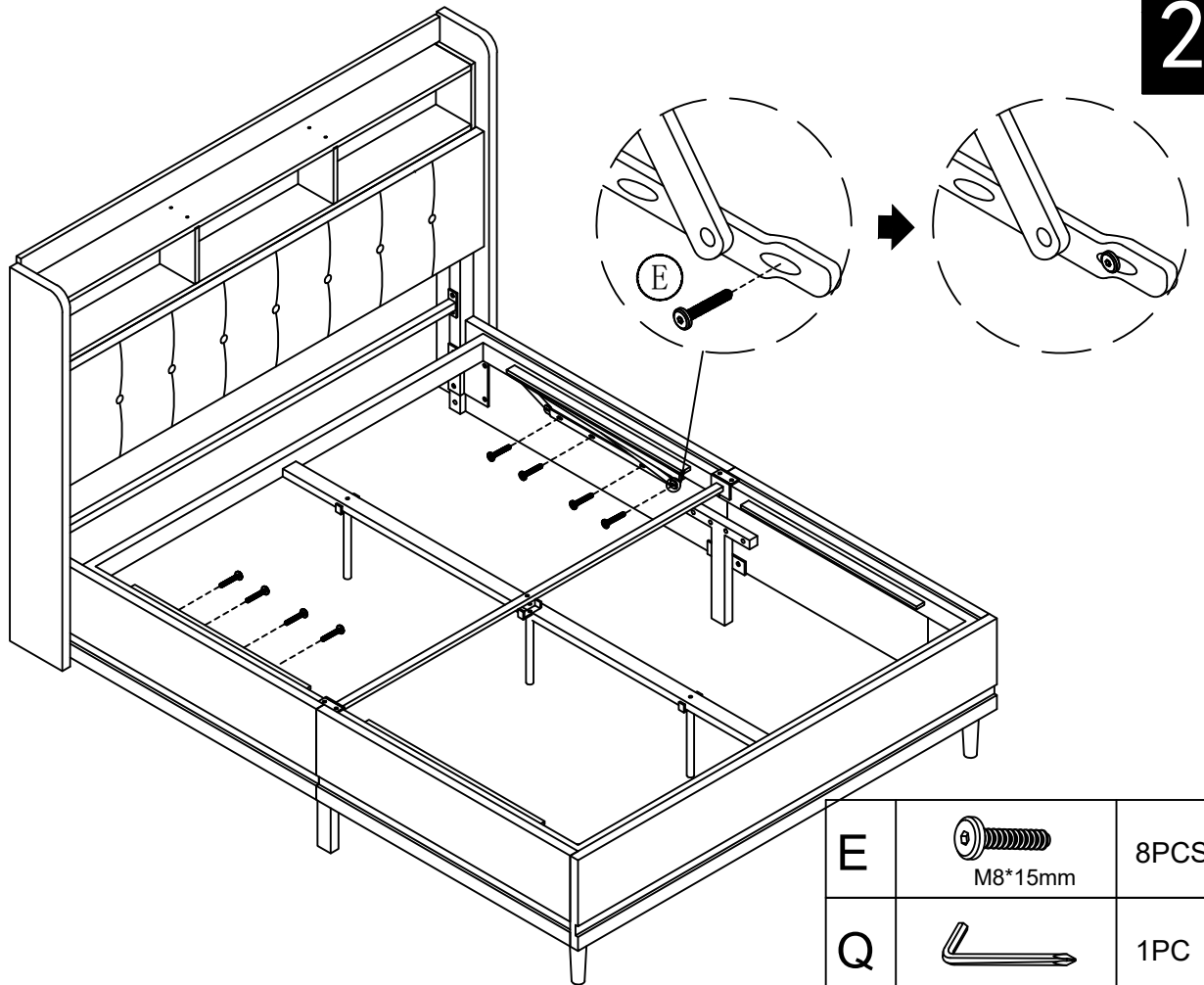

Flip the entire frame over. Attach part 31 to part 37 and part 32 to part 20.

A	 M6*20mm	10PCS
K	 M4	1PC



E	 M8*15mm	8PCS
Q		1PC

25



Note: Please twist the tip of piston to a correct position if unable to connect to the bolt.

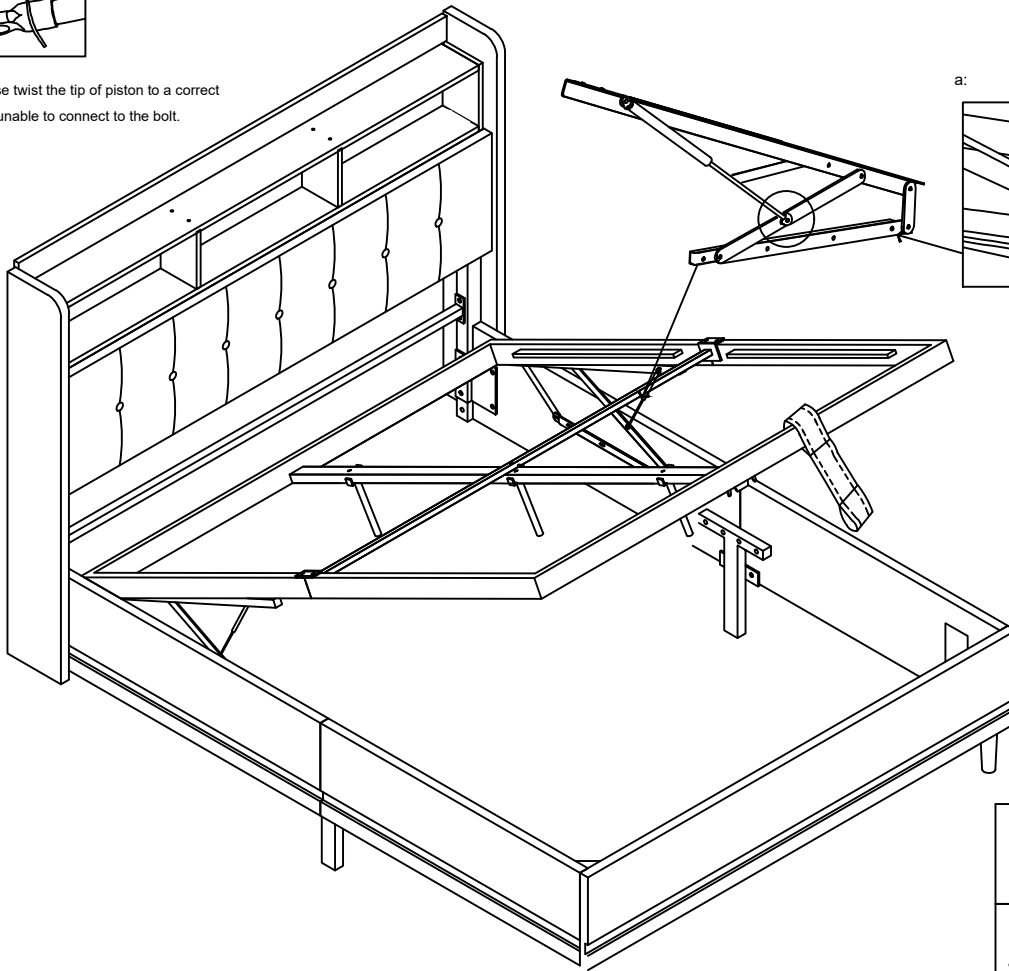

a:

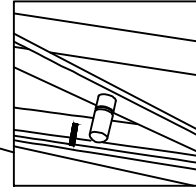

b:

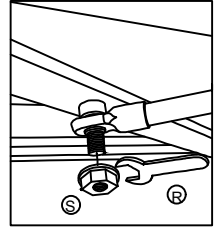

NB: Do not over tighten the Nuts.

R		1PC
S		4PCS

26

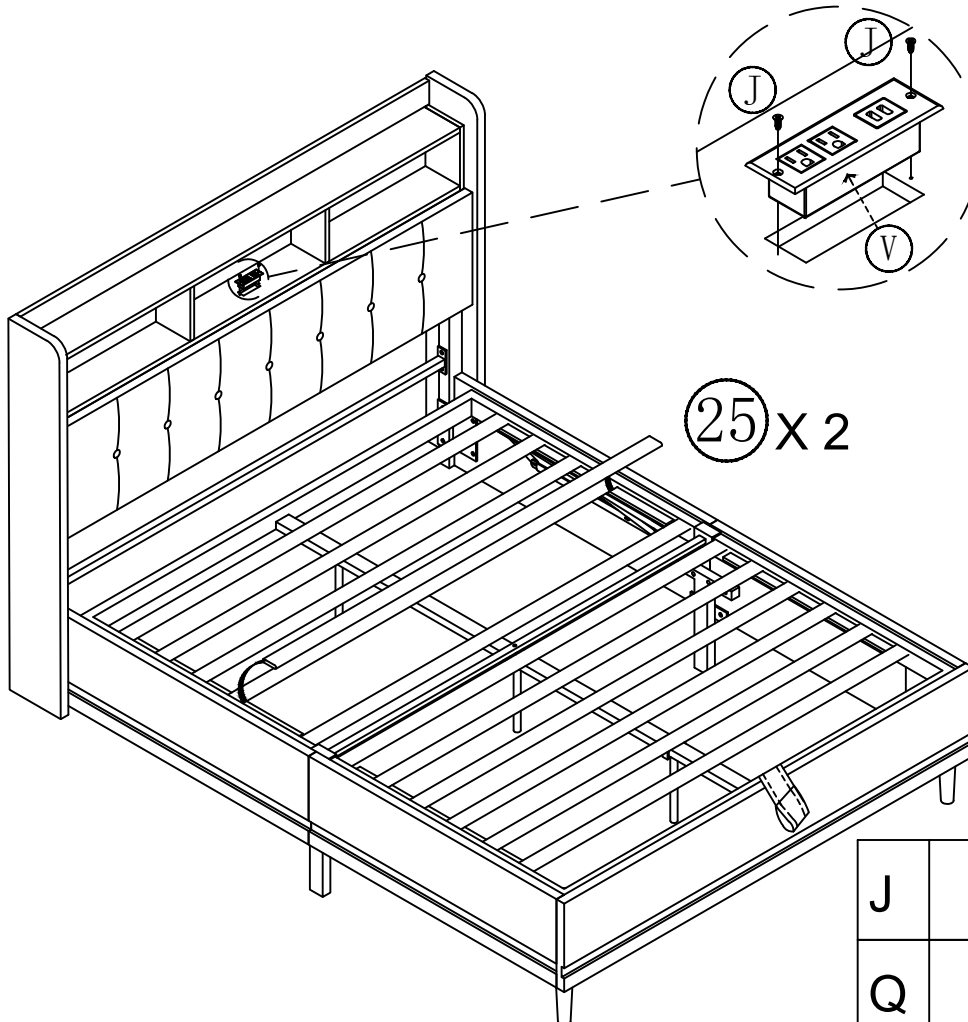

25 X 2

J	 M3.5*15mm	2PCS
Q	 M5	1PC

27

The two light strips need to be pulled out from the same side for easy wiring later on.

Attach the long LED strip to the bottom of the bed in the direction of the arrow.

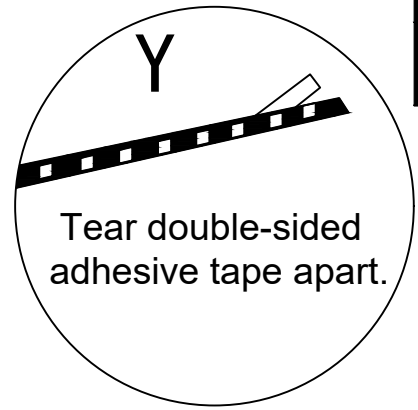

Tear double-sided adhesive tape apart.



Note:

The long LED strip is attached to the place as shown on the graph.

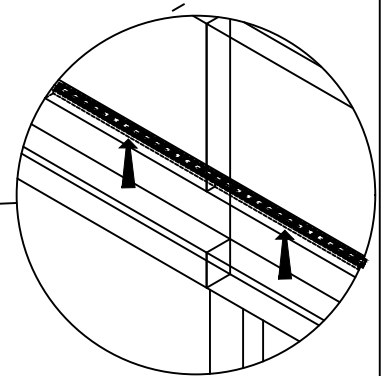

Y		1PC
---	--	-----

28

Pass the cable of the light strip on the bed frame through the through-hole on either side of part 11 to complete the wiring.

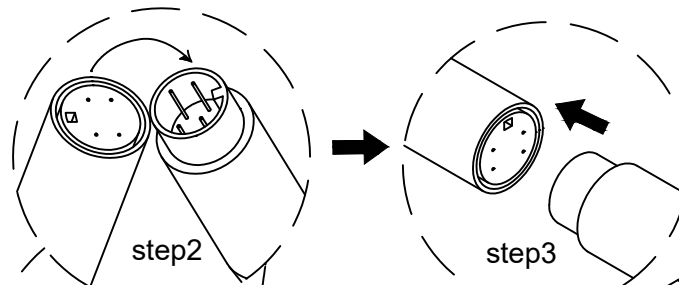

step2

step3

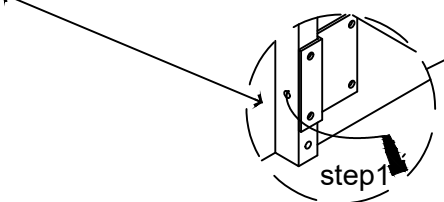

step1

step4

step4

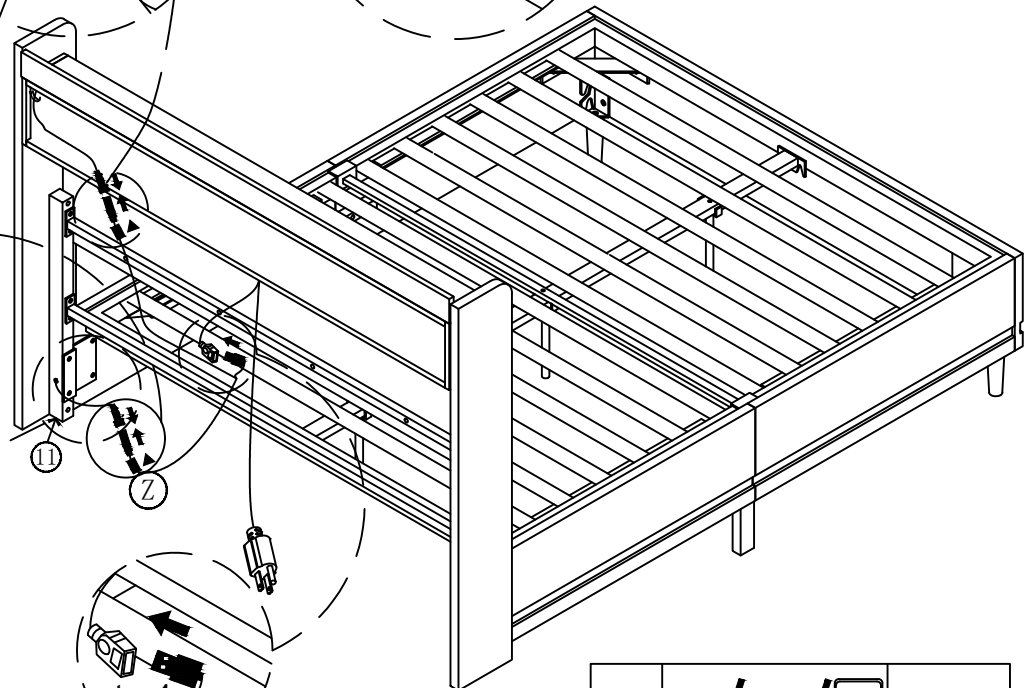

Z				1PC
---	--	--	--	-----

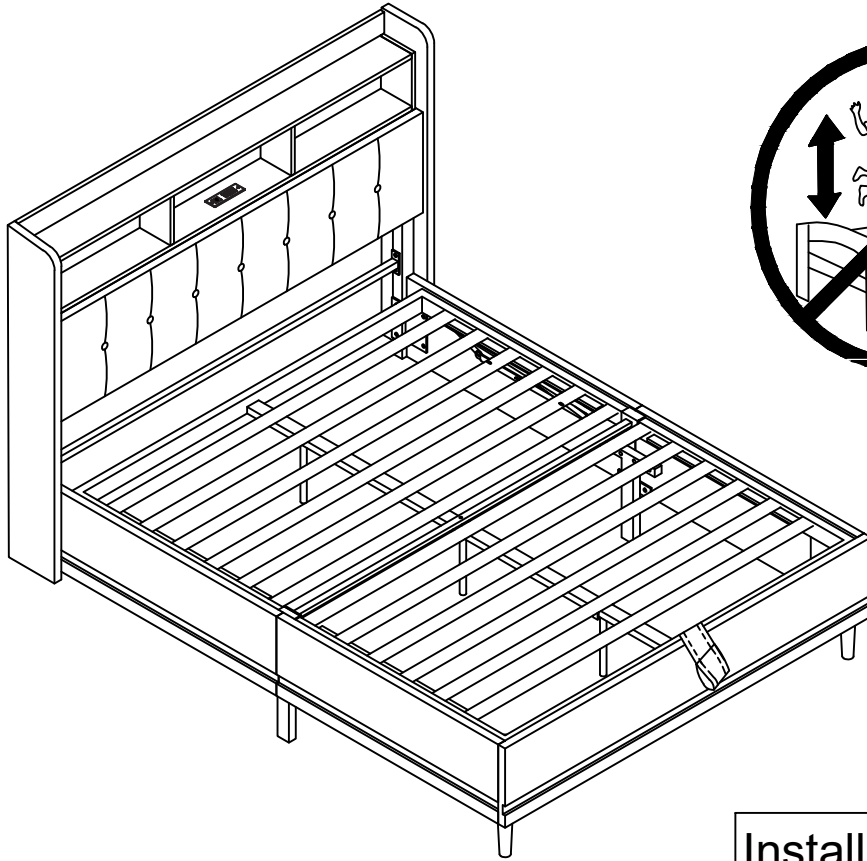

Installation Complete