





ASSEMBLY INSTRUCTIONS





BAR STOOL

Thank you for purchasing this quality product. Be sure to check all packing materials carefully for small parts, which may have come loose inside the carton during shipment. Identify and count all items and compare with the parts list and/or hardware list shown below.

PARTS LIST

NO	DESCRIPTION	SKETCH	QTY
1	CUSHION SEAT		2 PCS
2	STOOL LEG (L)		4 PCS
3	STOOL LEG (R)		4 PCS
4	UPPER STRETCHER (A)		4 PCS
5	LOWER STRETCHER (B)		4 PCS

HARDWARE LIST

NO	DESCRIPTION	SKETCH	QTY
A	JCBC BOLT - M6 x 60mm		16 PCS
B	SPRING WASHER - M6		16 PCS
C	FLAT WASHER - M6		16 PCS
D	ALLEN KEY - M4		1 PC
E	SCREW - M4 x 38mm		16 PCS

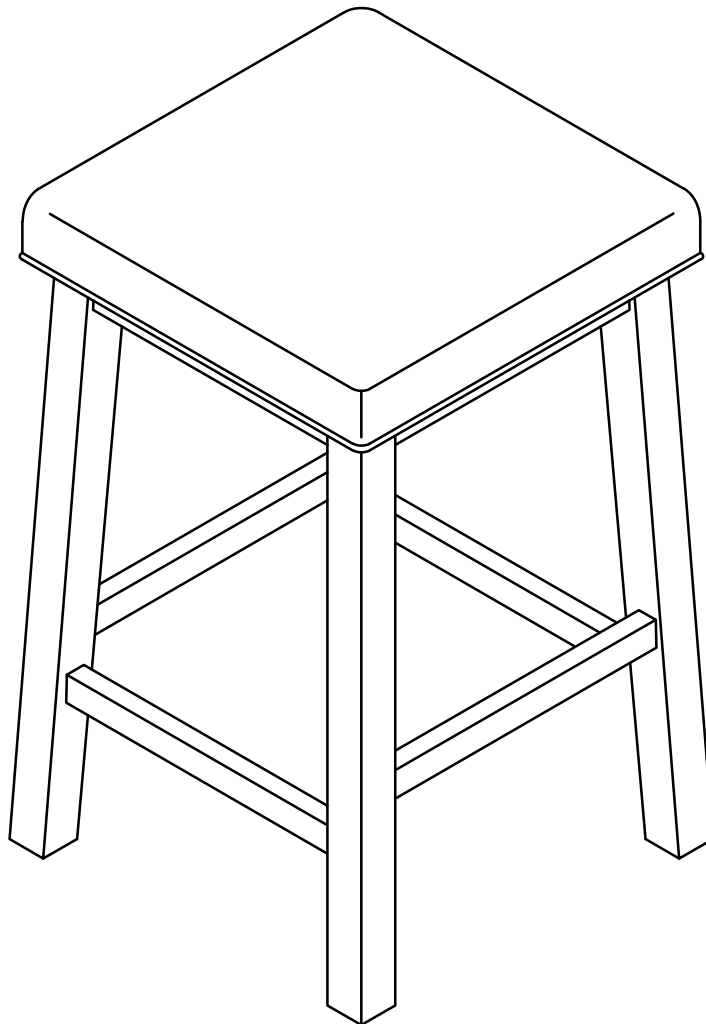

IMPORTANT NOTE :

- * Place all wooden parts on a clean and smooth surface such as a rug or carpet to avoid the parts from being scratched.
- * Check to be sure that you have all parts and hardware.
- * Remove all wrapping materials, including staples & packing straps before you start to assemble.
- * Do not tighten all screws/bolts until all completely assembled.
- * Keep all hardware parts out of reach of children.
- * We recommend that you assemble this product with the assistance of another person.

ASSEMBLY INSTRUCTIONS

BAR STOOL

Step 1

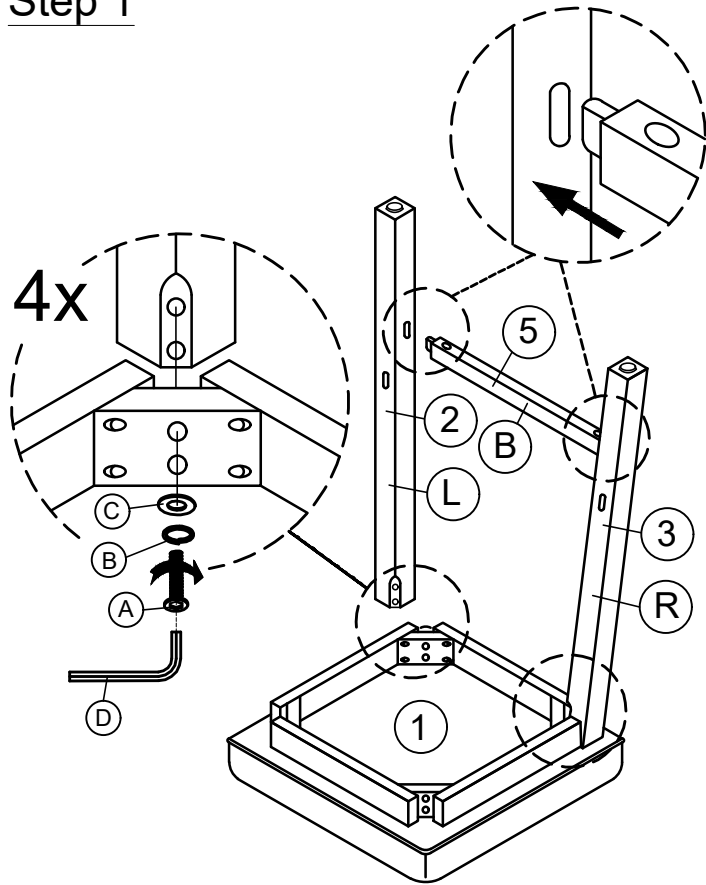

Step 2

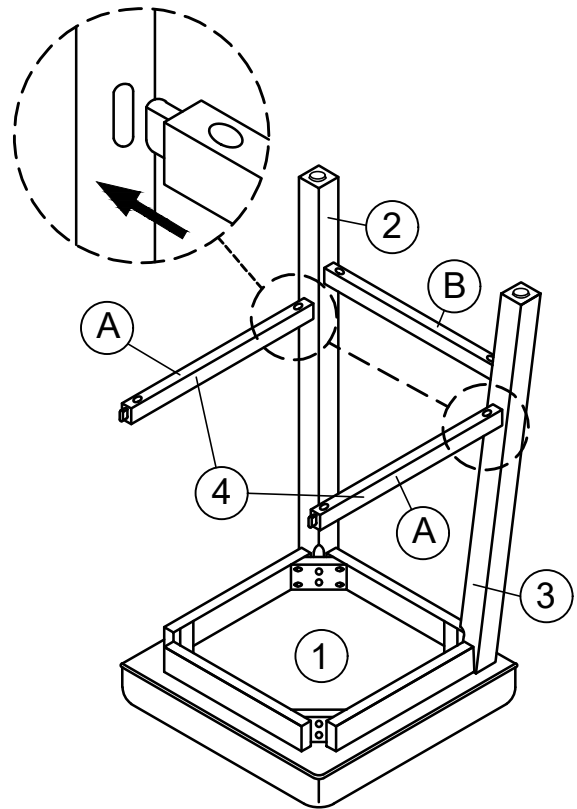

Step 3

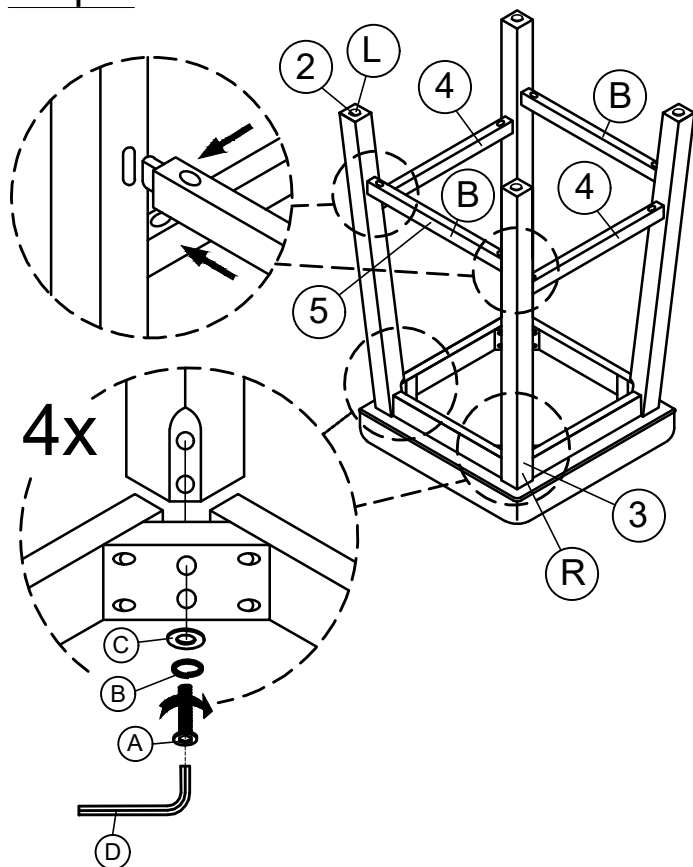

Step 4

