











Assembly Instructions

Caution : You must read this before you proceed

Care & Maintenance

- ⊘  ● Not for commercial use. For residential use only.
- ✓  ● Furniture may scratch floors. We recommend using furniture pads to protect your floors.
- ⊘  ● Do not put hot items directly on furniture surface.
- ⊘  ● Do not clean furniture with harsh cleansers or polish.
- ⊘  ● Do not place furniture under direct sunlight.
- ⊘  ● Do not place furniture near heating or cooling vents.
- ⊘  ● Do not write on furniture without a padded barrier to protect the surface.
- ⊘  ● Do not place furniture outside . For indoor use only.
- ⊘  ● Stains may be removed with mild soap solution and damp cloth.
- ⊘  ● Children should not climb or jump on the furniture.
- ✓  ● Dust and pick-up spills using a clean, non-colored, lint-free cloth.

Please look in carton for hardware packs and legs.



Kitchen Island

N780P421577

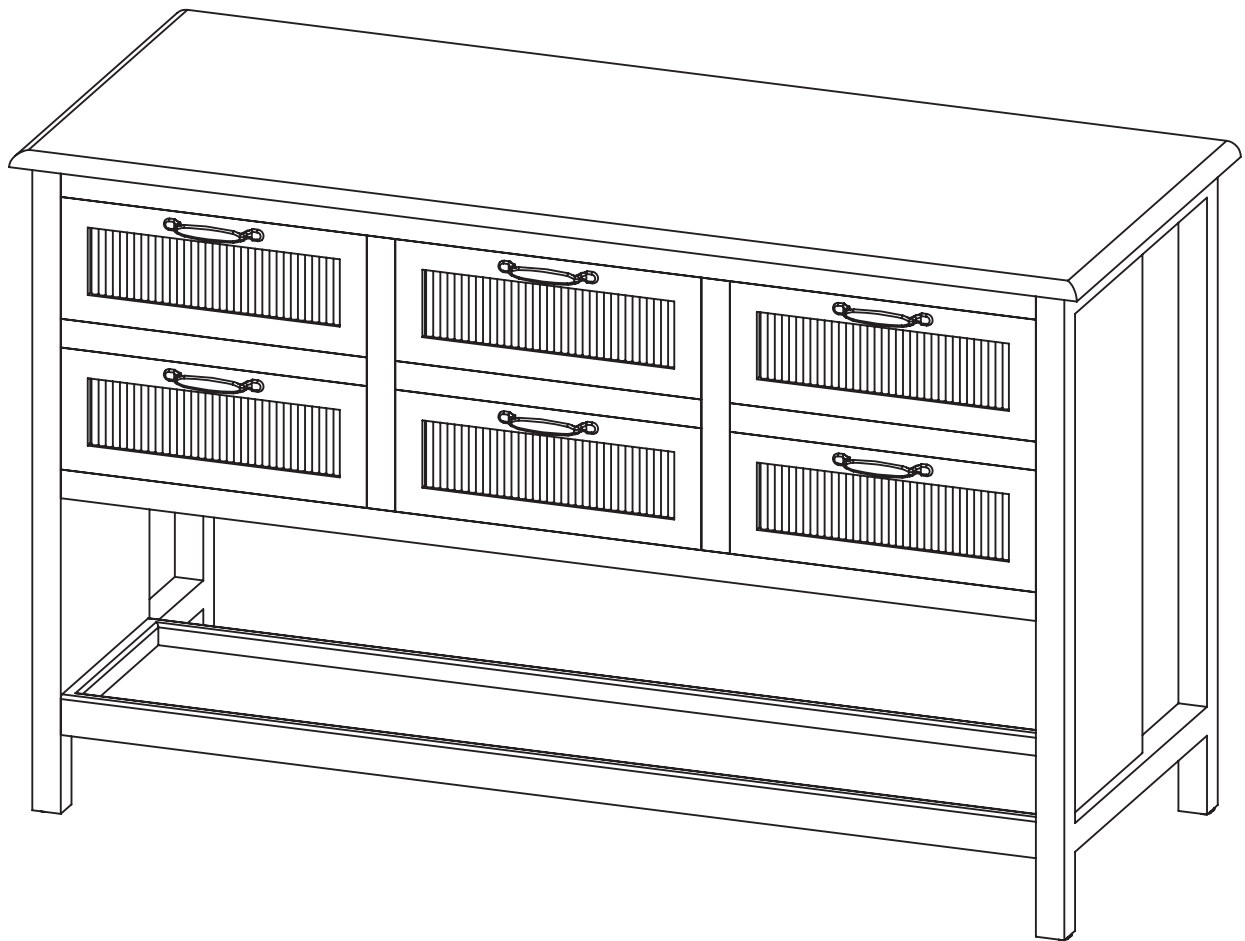



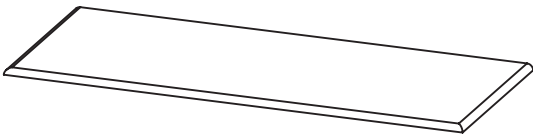

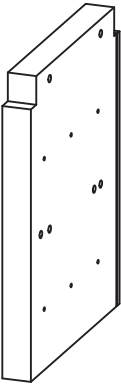
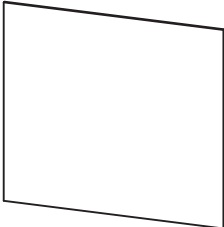
N780P421578





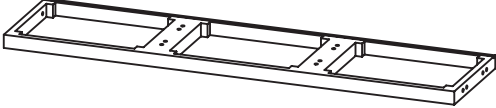

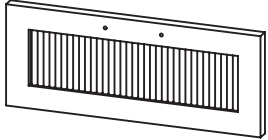
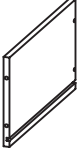
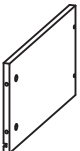



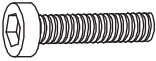

N780P421577 Parts List

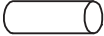
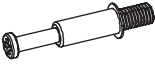
Label	Picture	Description	QTY
A	 A perspective drawing of a thin, rectangular panel.	Top Panel	1
B	 A perspective drawing of a vertical panel with a frame and several small circular holes.	Left Side Panel	1
C	 A perspective drawing of a vertical panel with a frame, similar to the left side panel but with a different hole pattern.	Right Side Panel	1
D	 A perspective drawing of a vertical panel with a frame and several small circular holes.	Middle Panel	2
E	 A perspective drawing of a thin, rectangular panel, similar to the top panel.	Back Panel	3

N780P421578 Parts List

Label	Picture	Description	QTY
F		Up Frame	1
G		Middle Frame	3
H		Down Frame	1
I		Bottom Panel	1
J		Drawer Panel	6
K		Drawer Left Panel	6
L		Drawer Right Panel	6
M		Drawer Back Panel	6
N		Drawer Bottom Panel	6

N780P421577 Hardware

Label	Picture	Description	QTY
①		Bolt (Ø6*35mm)	32+3
②		Flat Washer	32+3
③		Dowel (Ø8*20mm)	28+3
④		Cam Bolt (Ø6*35mm)	36+4
⑤		Cam Nut (Ø15*9mm)	36+4
⑥		Slide Rail(10inch)	12
⑦		Knob	6
⑧		Bolt (Ø4*25mm)	12+1
⑨		Screw (Ø3*10mm)	36+4
⑩		Screw (Ø3.5*25mm)	24+3
⑪		Screw (Ø3*14mm)	36+4
⑫		L-type Hexagon Wrench	1

Assembly Preparation

Before
Beginning
Assembly:

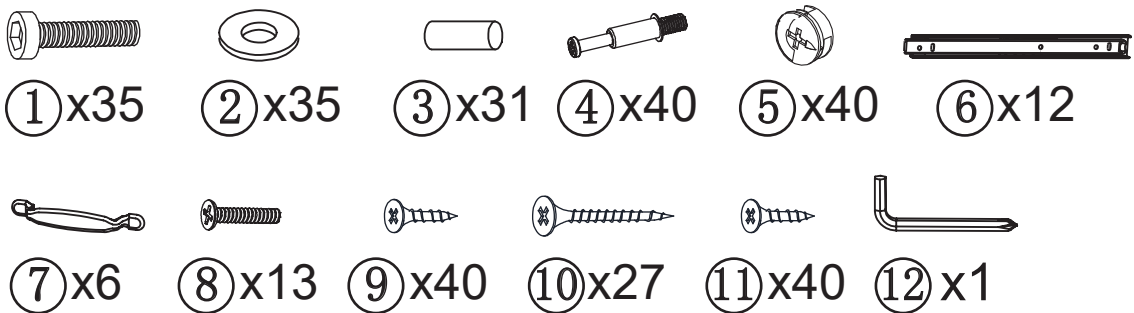
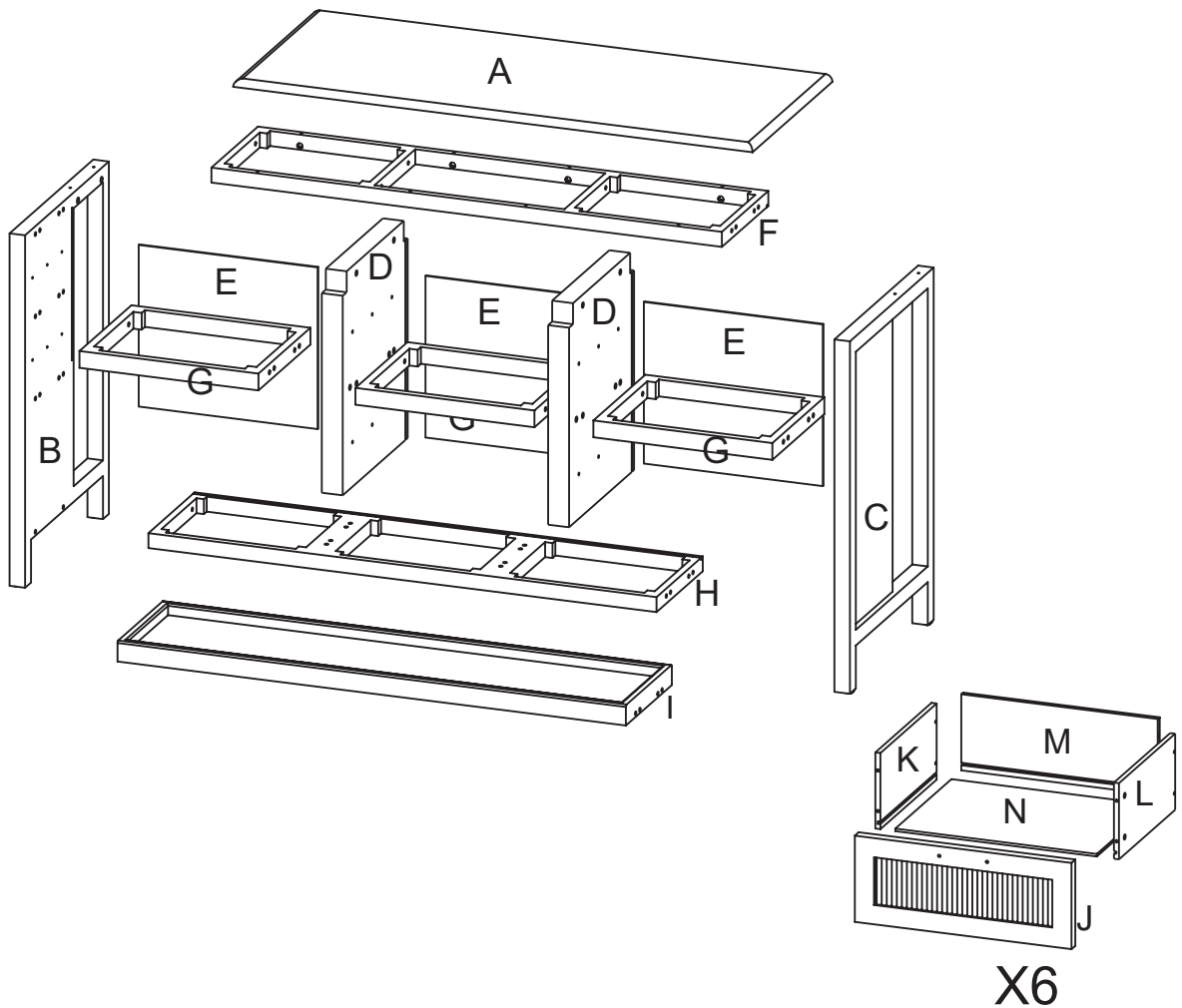

- Read instructions, cover to cover-



- Have 2 adults on hand for assembly-



- Do not assemble on flooring or carpet-



- Assemble on a clean non-marring surface (packing foam)-



- Save all packaging until finished-

Assembly Steps

Overview

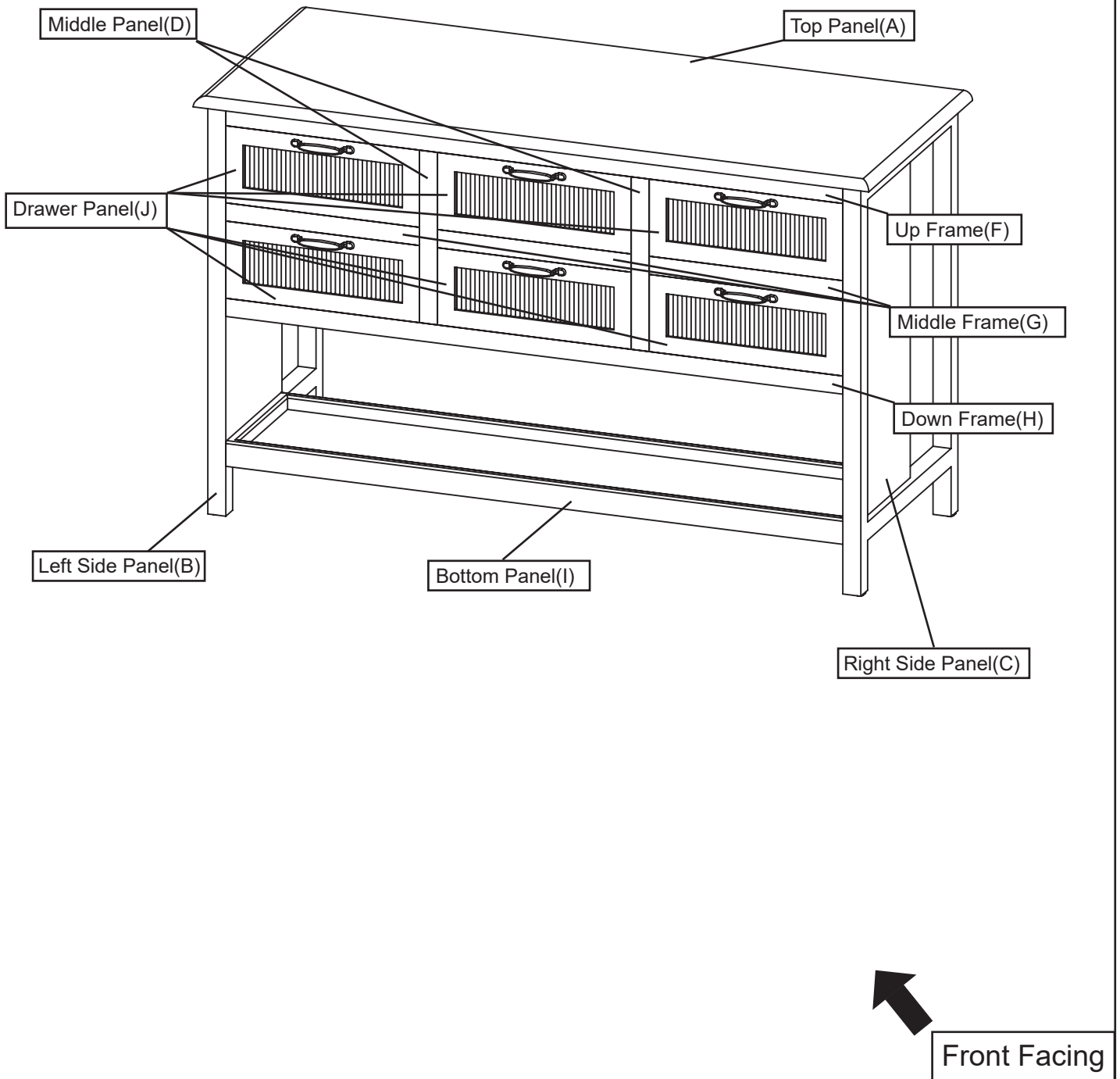

This kitchen Island has multiple parts and may require up to 60 minutes to assemble. To give you an overview of the kitchen Island parts, the above picture is to help you put the various parts into perspective. Please read through the instructions below to familiarise yourself with the parts and steps before assembly.

Step 1

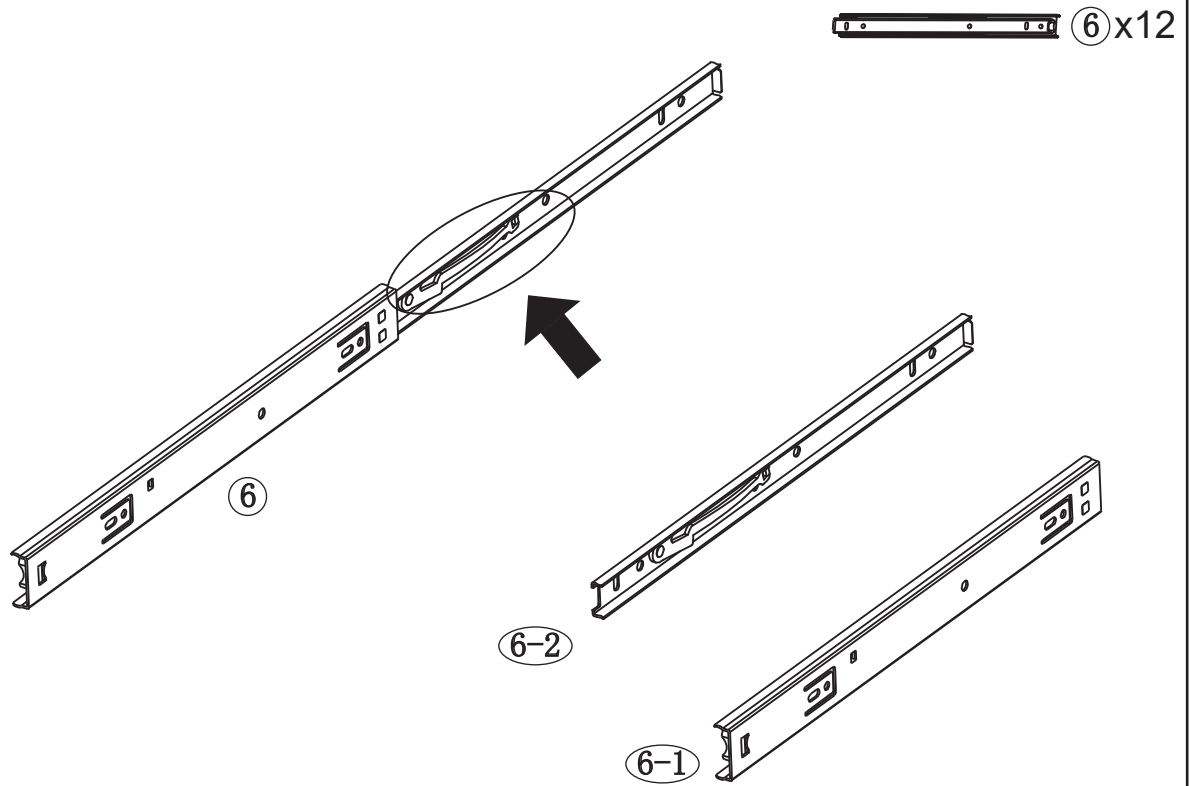

Open the slide rail (6) and divide it into (6-1) and (6-2).

Step 2

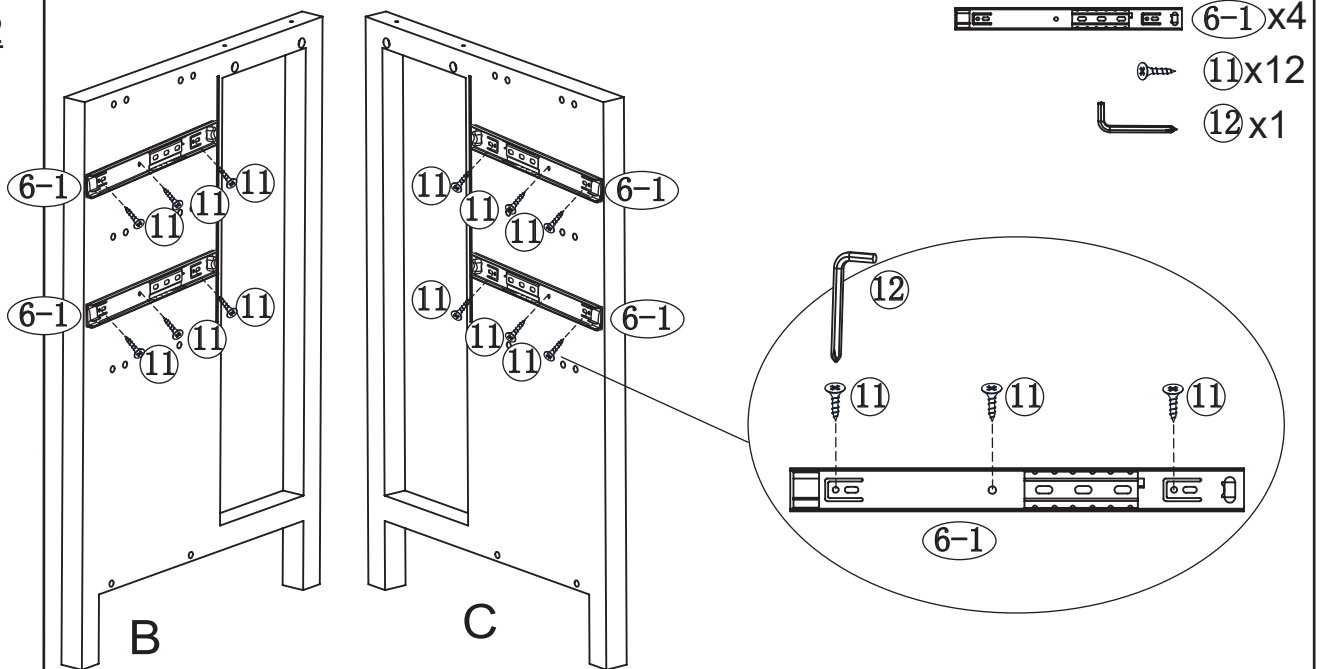

Attach the slide rail (6-1) to the left side panel (B) with screw (11) using L-type hexagon wrench (12). Repeat the previous steps to the right side panel (C).

Step 3

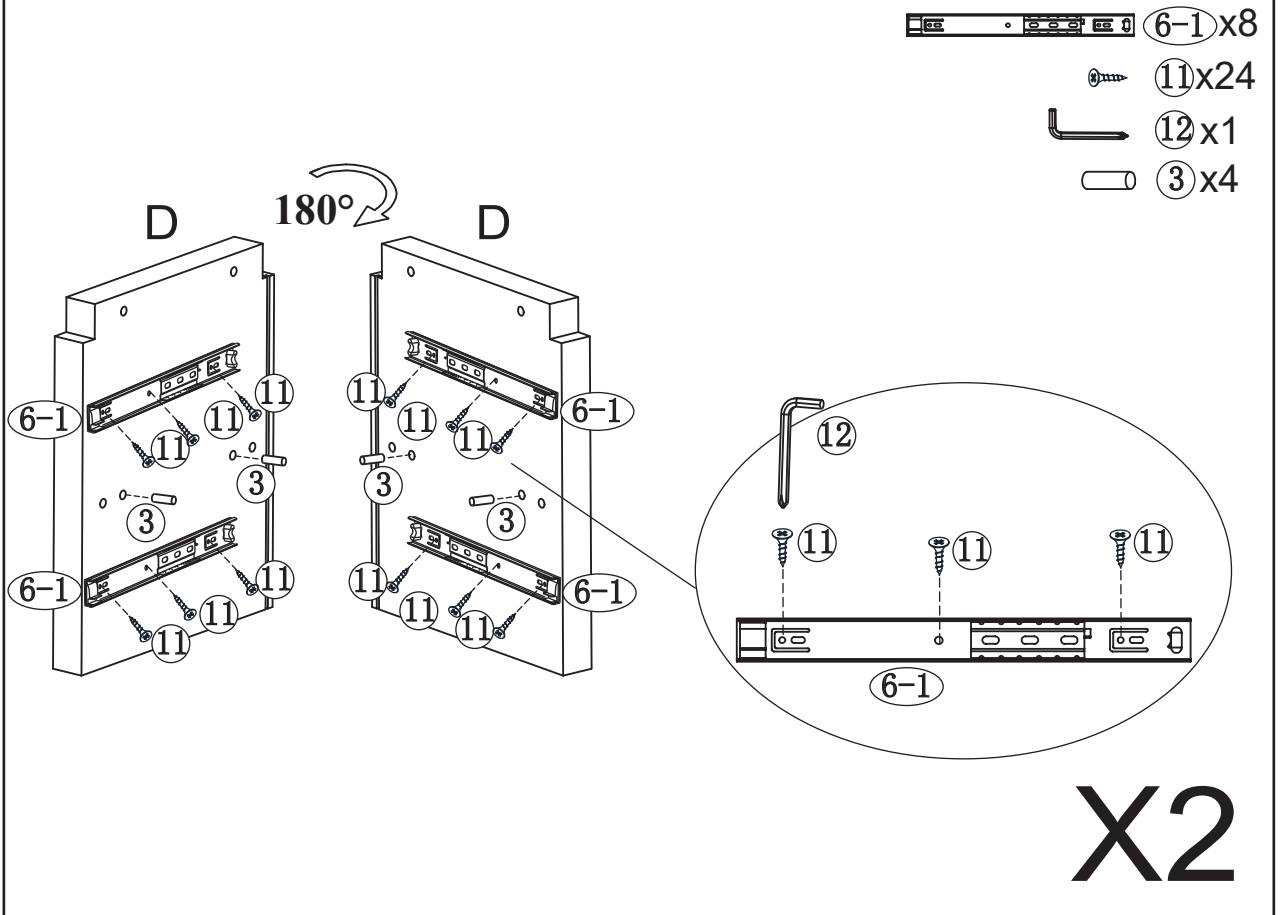

Attach the slide rail (6-1) to the middle panel(D) with screw(11)using I-type hexagon wrench(12).Fix the dowel(3) to the middle panel(D).

Step 4

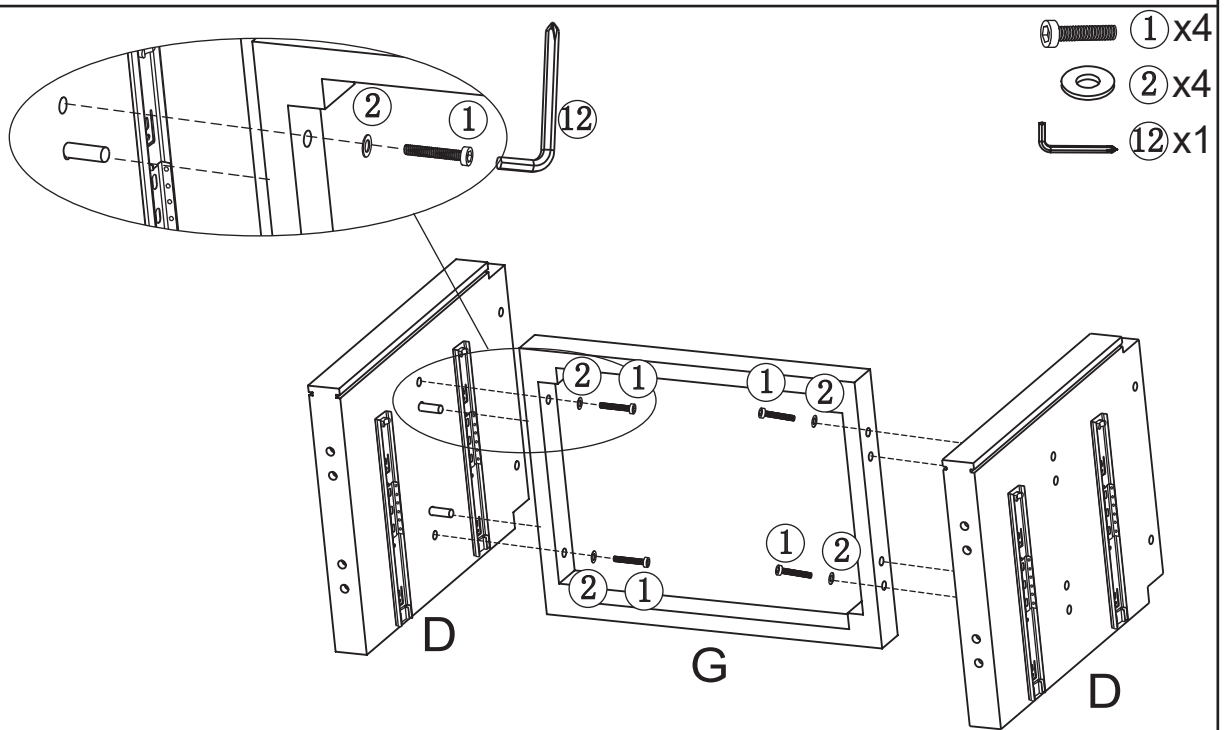

Attach the middle frame (G) to the middle panel(D) with bolt(1) and flat washer(2) using I-type hexagon wrench(12).

Step 5

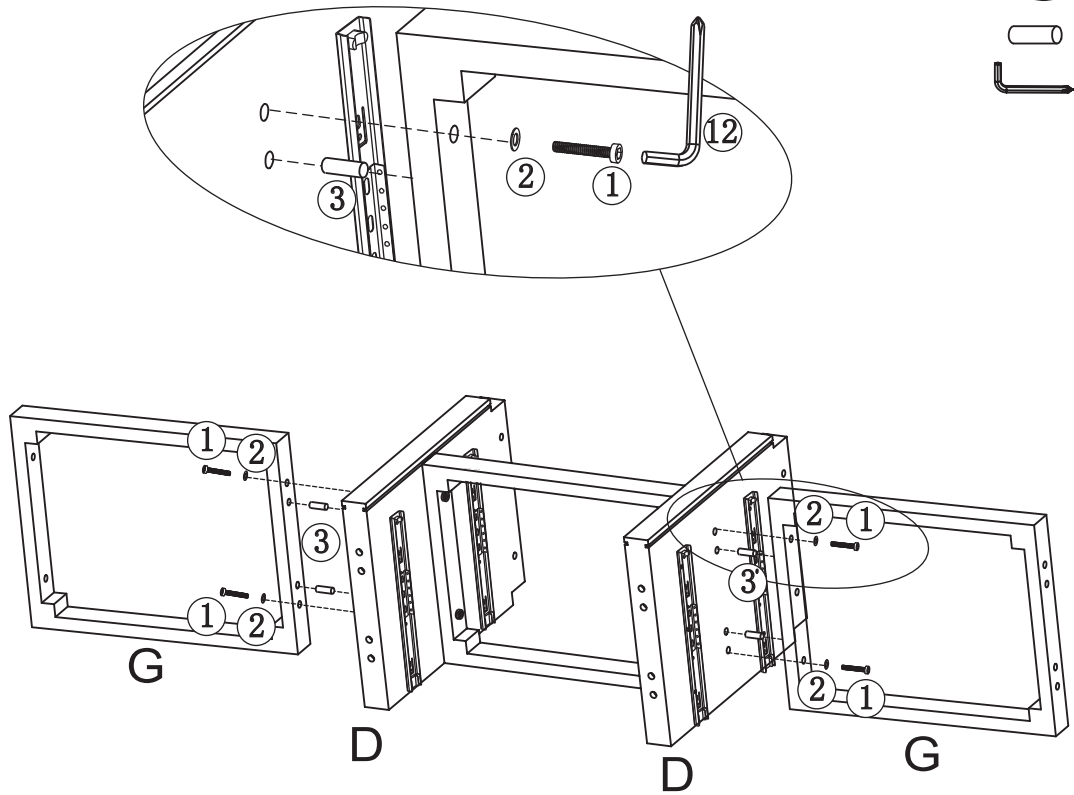

Attach the middle frame (G) to the middle panel(D) with bolt(①), flat washer(②) and dowel(③)using I-type hexagon wrench(⑫).

Step 6

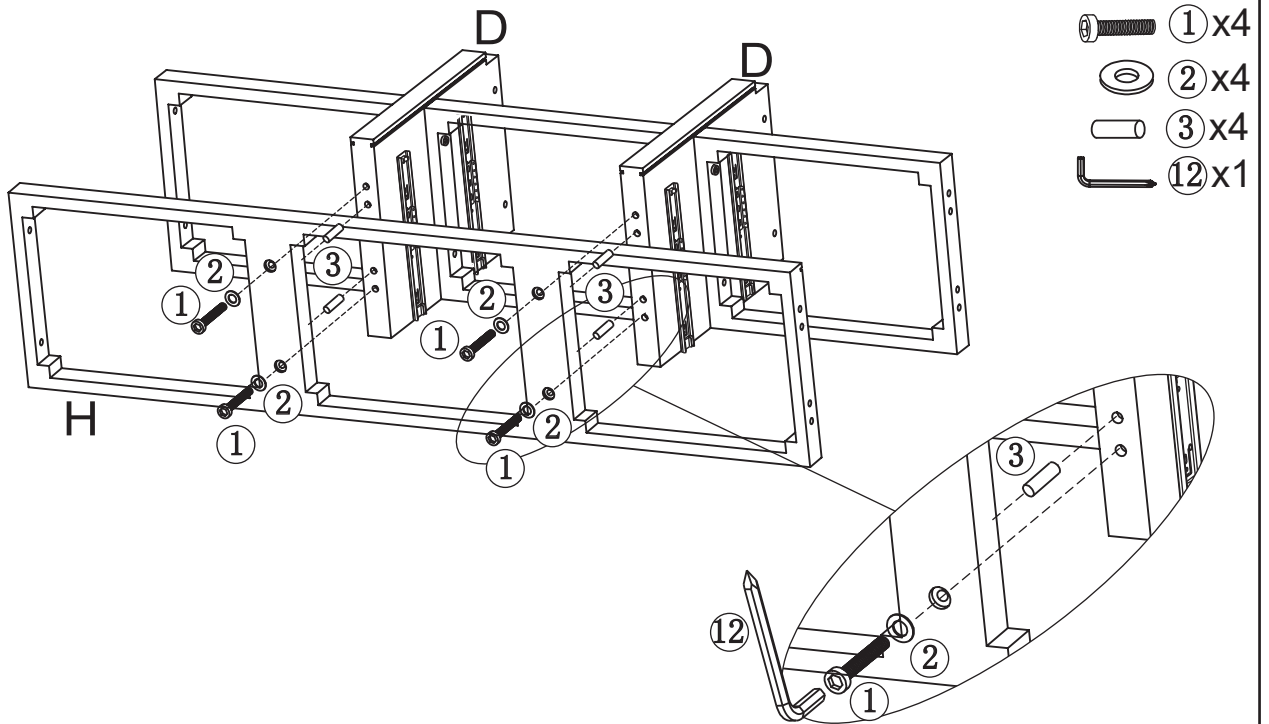

Attach the down frame (H) to the middle panel(D) with bolt(①), flat washer(②) and dowel(③)using I-type hexagon wrench(⑫).

Step 7

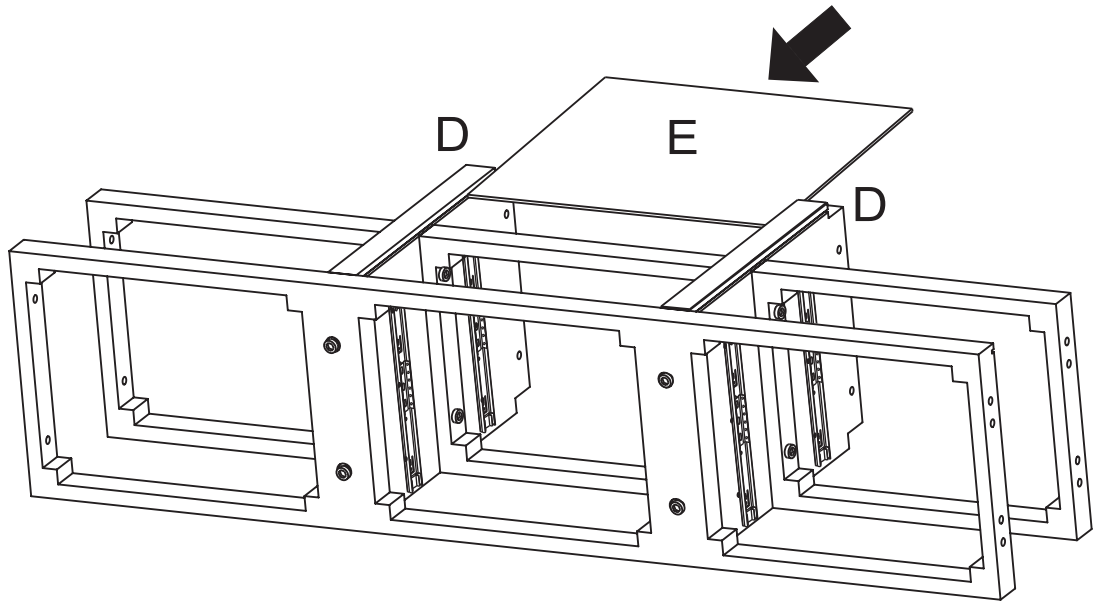

Insert back panel(E) into the groove of the middle panel(D).

Step 8

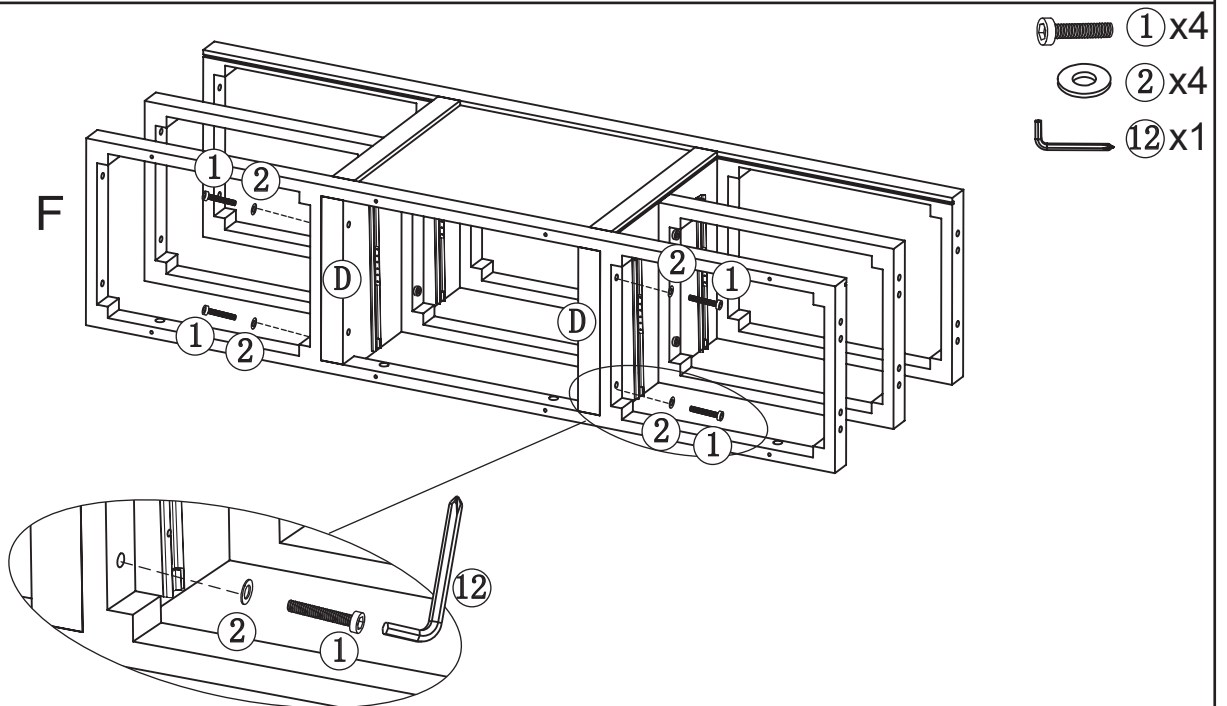

Attach the up frame (F) to the middle panel(D) with bolt(①) and flat washer(②) using I-type hexagon wrench(⑫).

Step 9

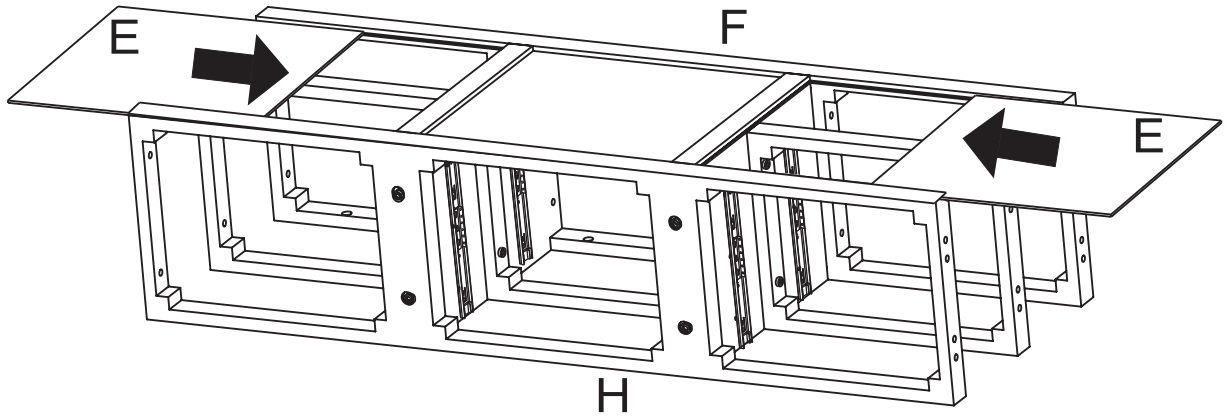

Insert back panel(E) into the groove of the up frame (F) and the down frame (H).

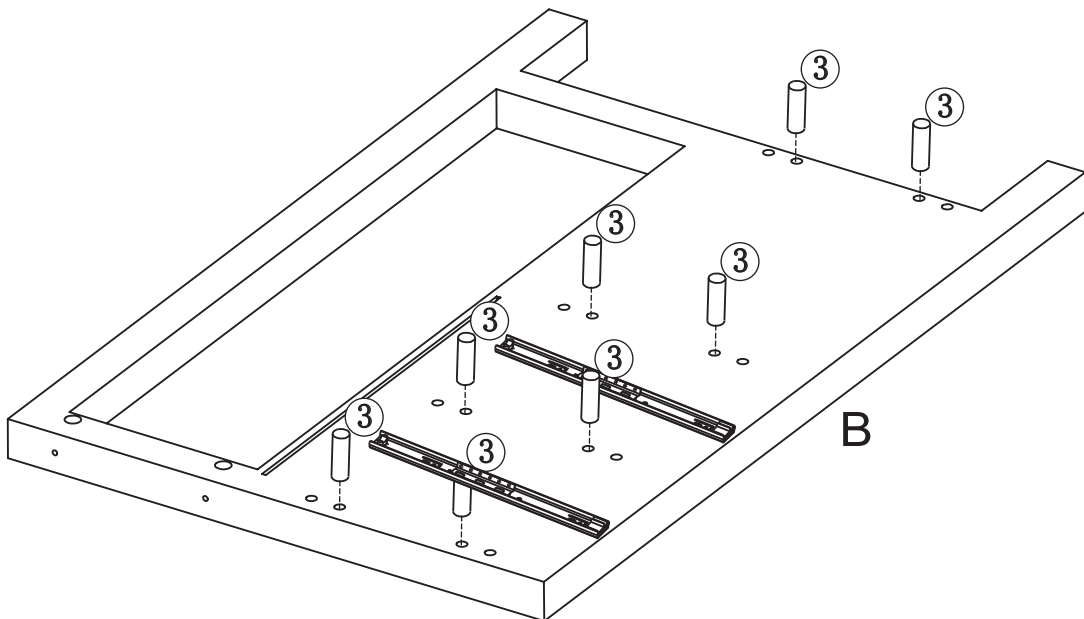

Step 10

 ③x8



Fix the dowel(③) to the left side panel(B).

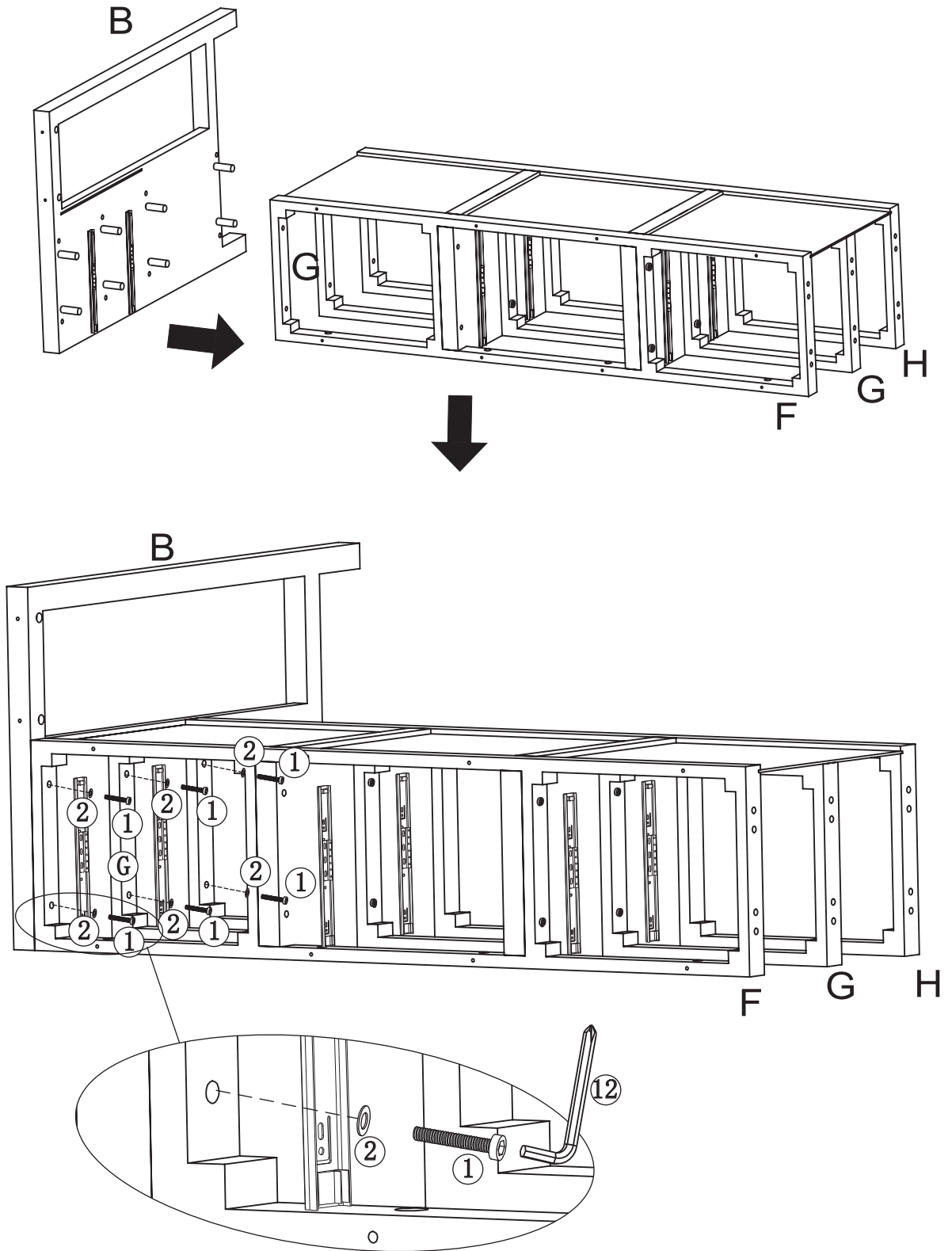

Step 11

-  ① x6
-  ② x6
-  ⑫ x1



Attach the left side panel(B) to the up frame (F),the middle frame (G) and the down frame (H) with bolt(①)and flat washer(②) using I-type hexagon wrench(⑫).

Step 12

-  ①x2
-  ②x2
-  ⑫x1

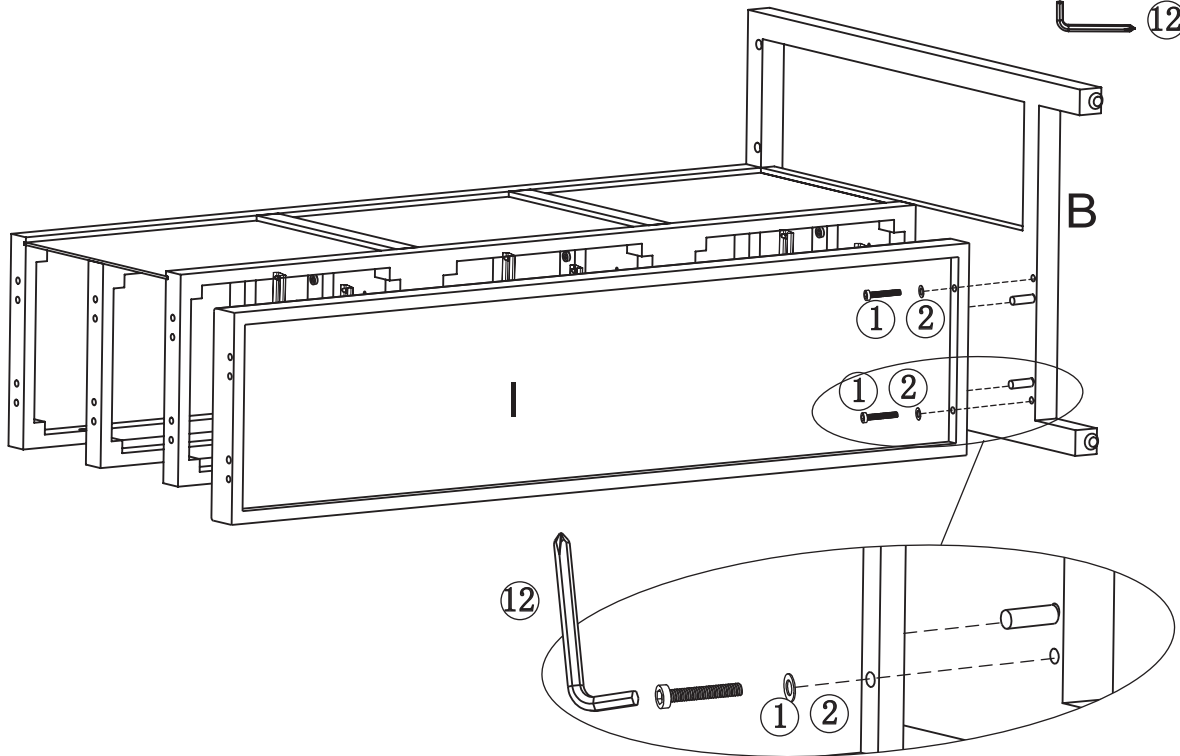

Attach the left side panel (B) to the bottom panel (I) with bolt(①) and flat washer(②) using I-type hexagon wrench(⑫).

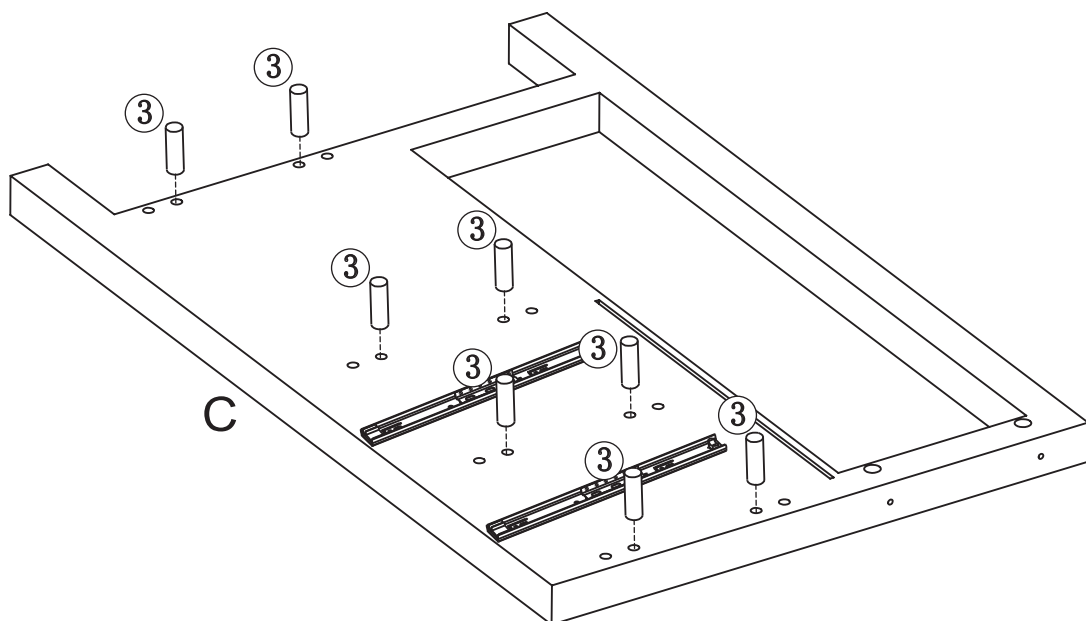

Step 13

-  ③x8



Fix the dowel(③) to the right side panel(C).

Step 14

-  ① x8
-  ② x8
-  ⑫ x1

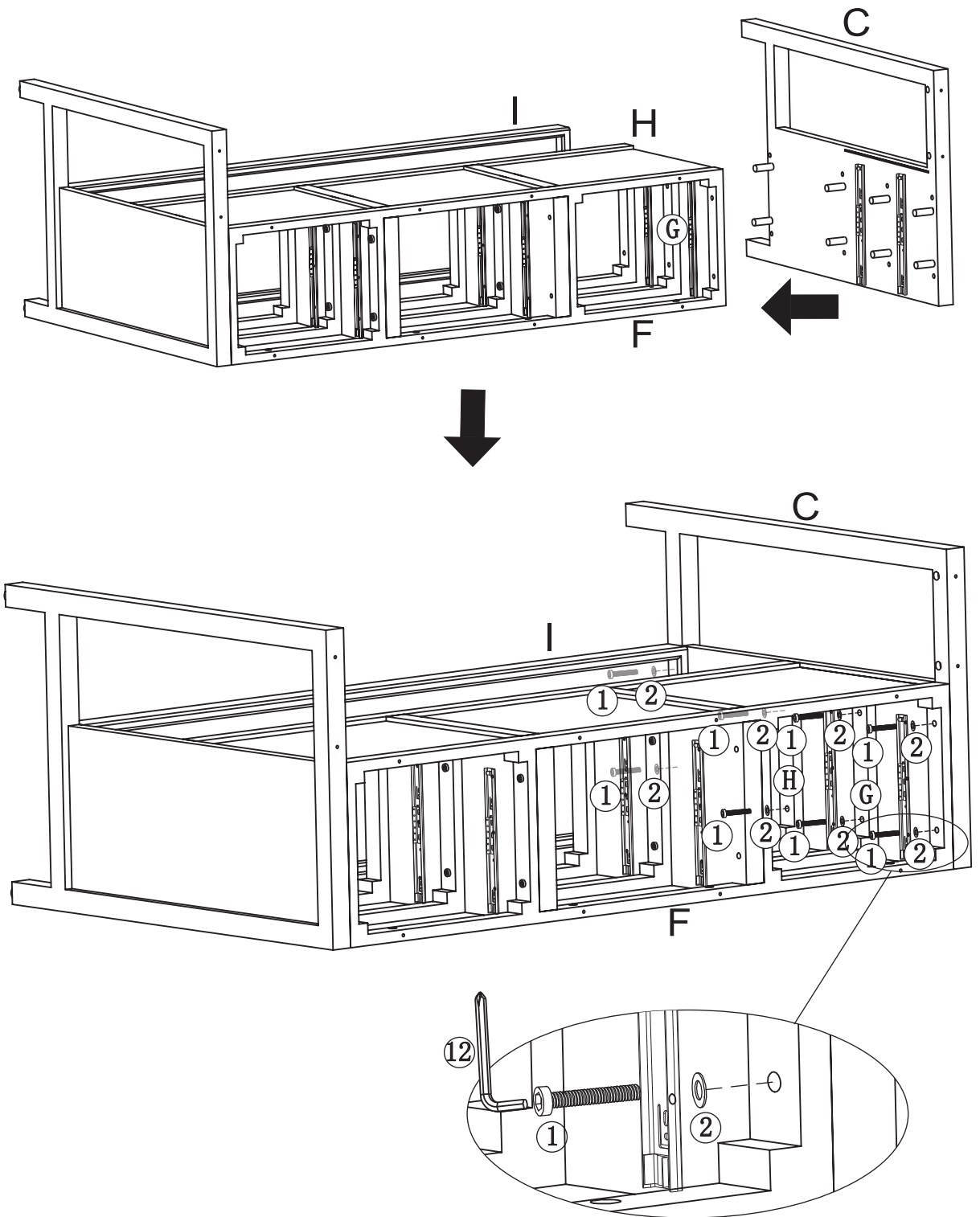

Attach the right side panel(C) to the up frame (F),the middle frame (G),the down frame (H) and the bottom panel (I) with bolt(①) and flat washer(②) using I-type hexagon wrench(⑫).

Step 15

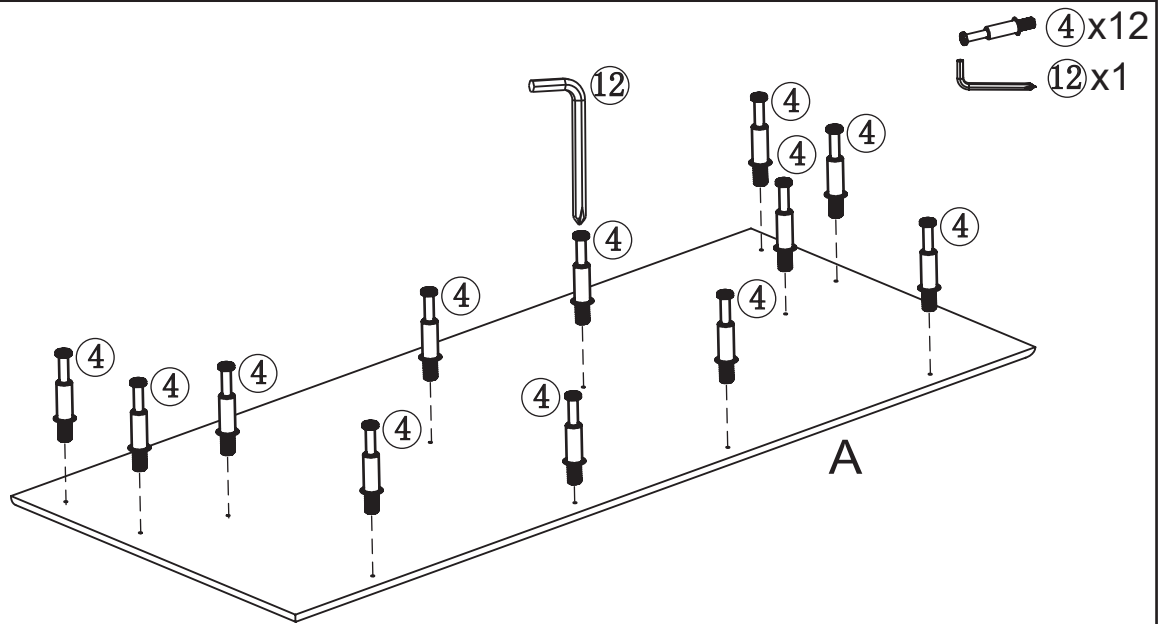



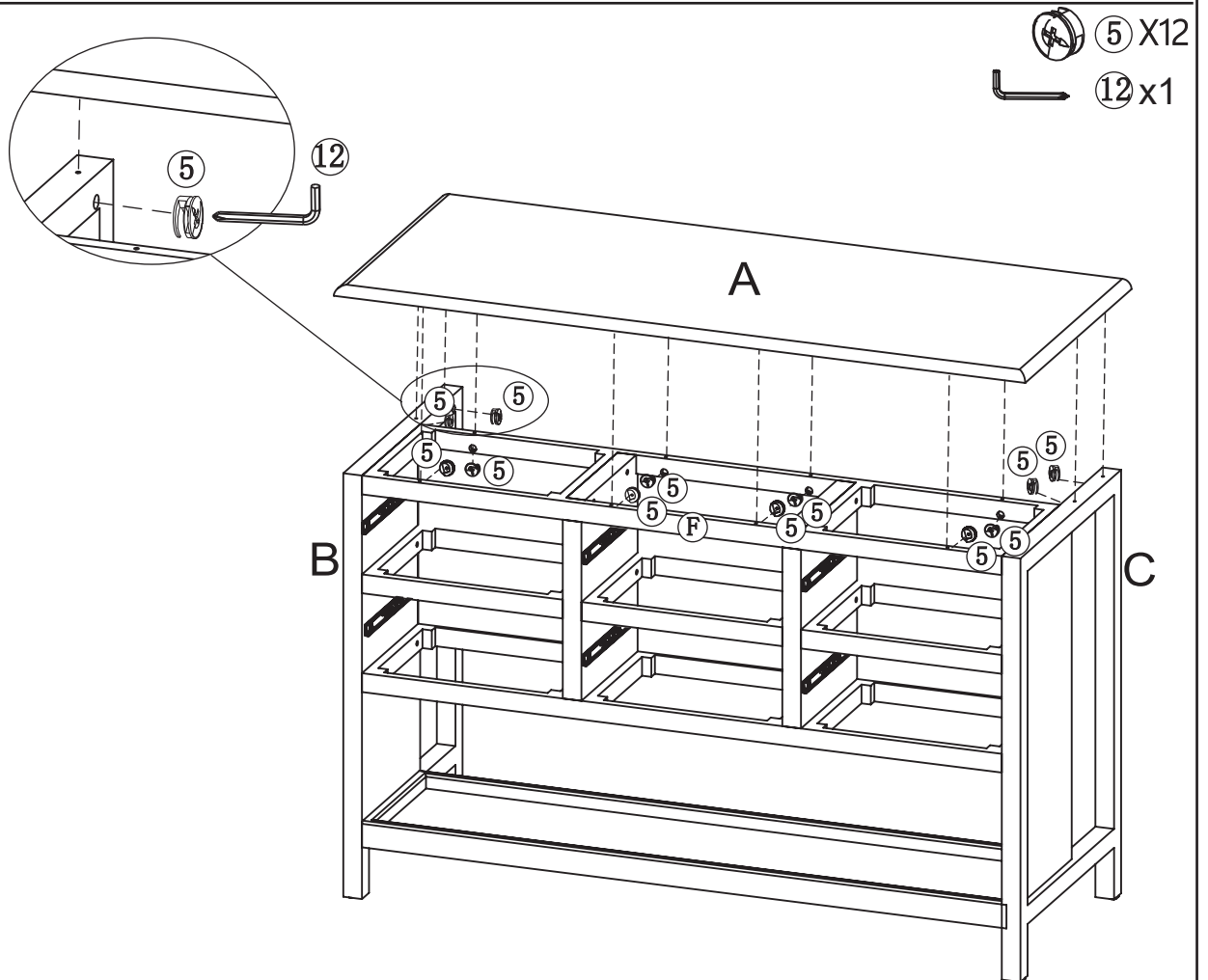

Attach cam bolt(4) to the top panel (A) using I-type hexagon wrench (12).

Step 16



Attach the top panel (A) to the left side panel(B),the right side panel(C) and the up frame (F) with cam nut(5) using I-type hexagon wrench (12).

Step 17

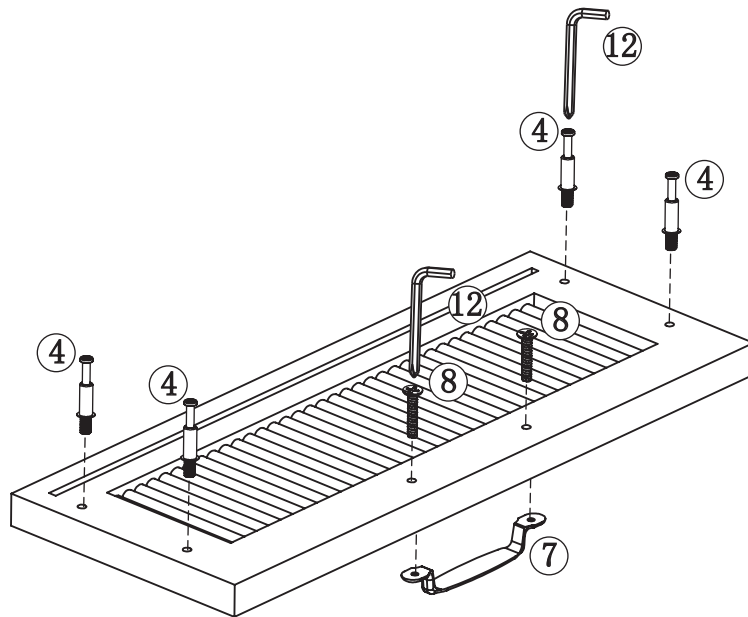

-  ④x24
-  ⑦x6
-  ⑧x12
-  ⑫x1



x6

Attach knob (⑦) to the drawer panel (J) with bolt (⑧) using I-type hexagon wrench(⑫).
Attach cam bolt(④) to the drawer panel (J) using I-type hexagon wrench (⑫).

Step 18

-  ⑨ X36
-  ⑥-2 x12
-  ⑫x1

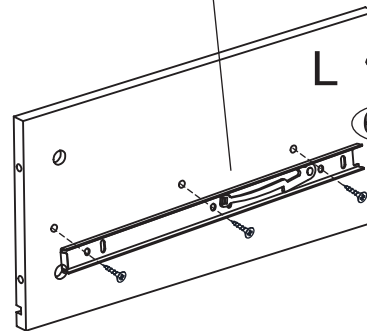
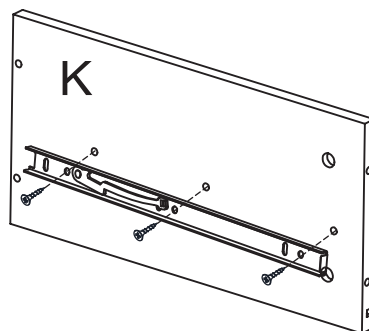
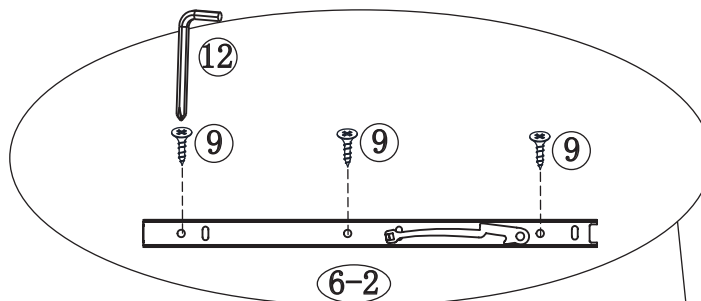

x6

Attach the slide rail (⑥-2) to drawer left panel(K) with screw(⑨)using I-type hexagon wrench(⑫).Repeat the previous steps to drawer right panel(L).

Step 19

⑩x24
⑫x1

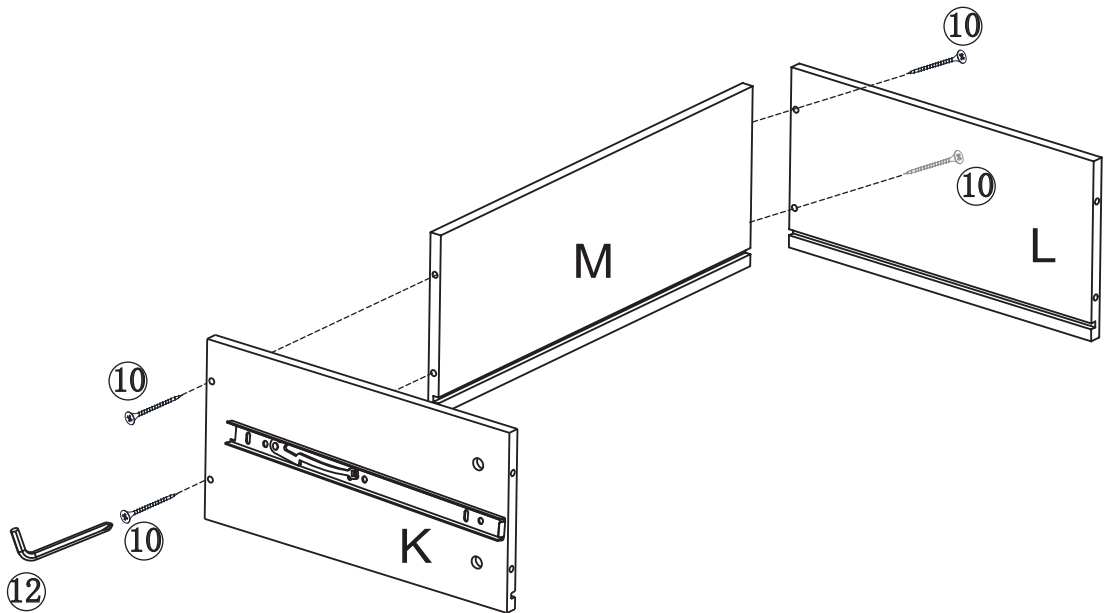

x6

Attach drawer left panel(K) to drawer back panel (M) with screw (⑩) using I-type hexagon wrench(⑫).Repeat the previous steps to drawer right panel(L).

Step 20

⑤ X24
⑫x1

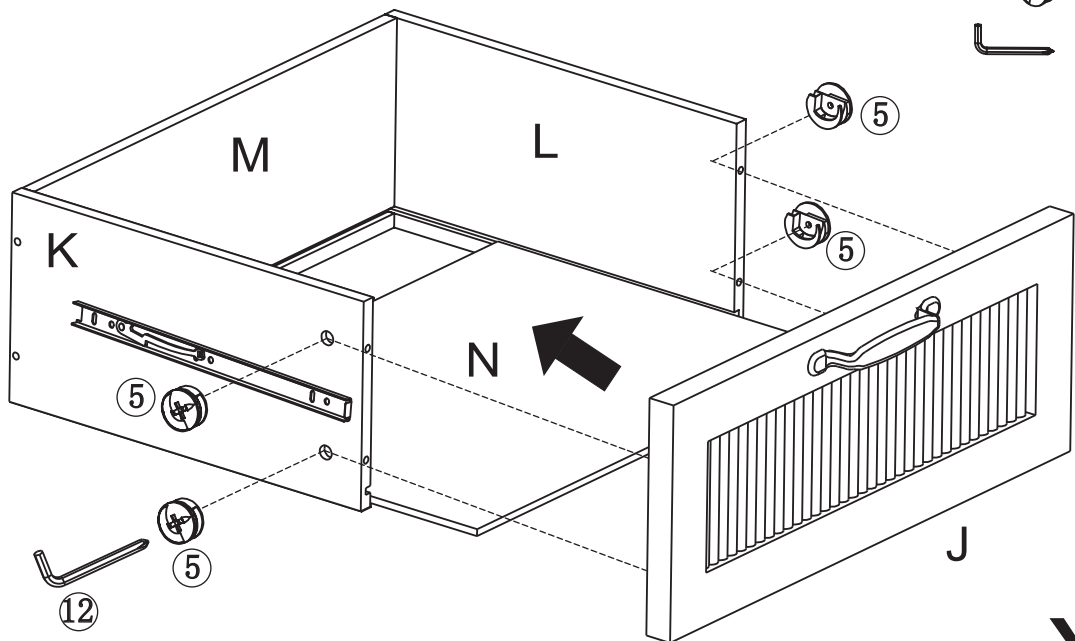

x6

Insert drawer bottom panel(N) into the groove of drawer left panel(K) and drawer right panel(L). Attach drawer panel(J) to drawer left panel(K) with cam nut(⑤) using I-type hexagon wrench(⑫).Repeat the previous steps to drawer right panel(L).

Step 21

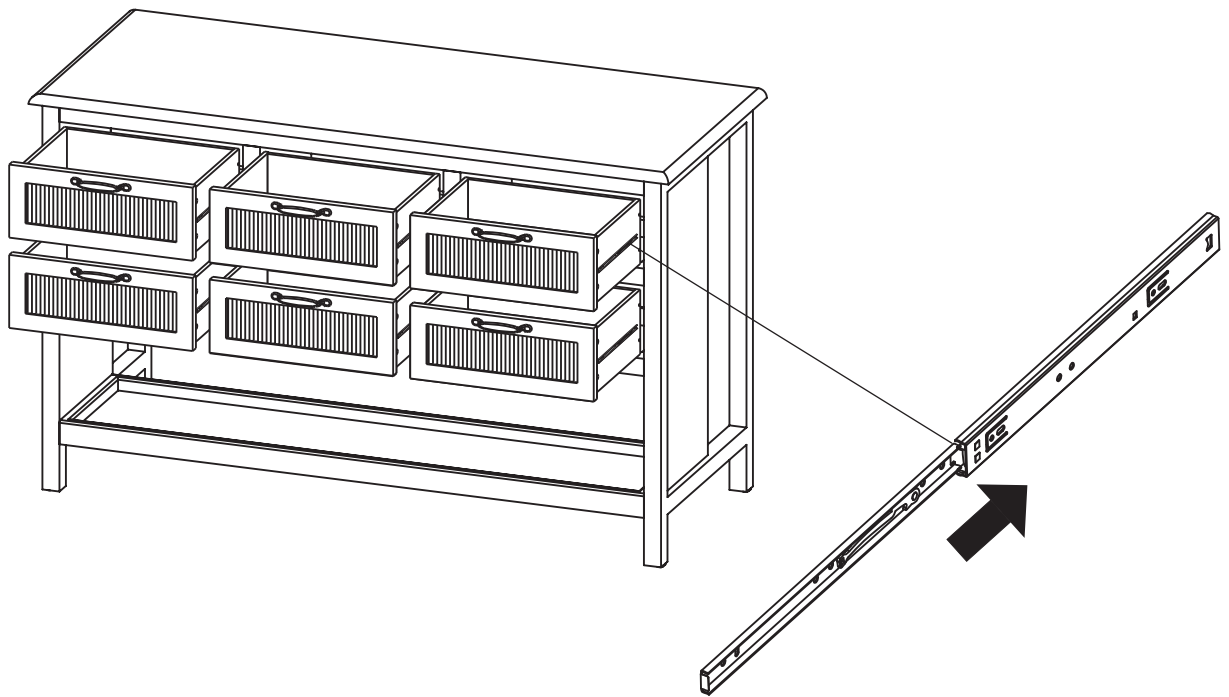

Please put the drawer in the table.

Step 22

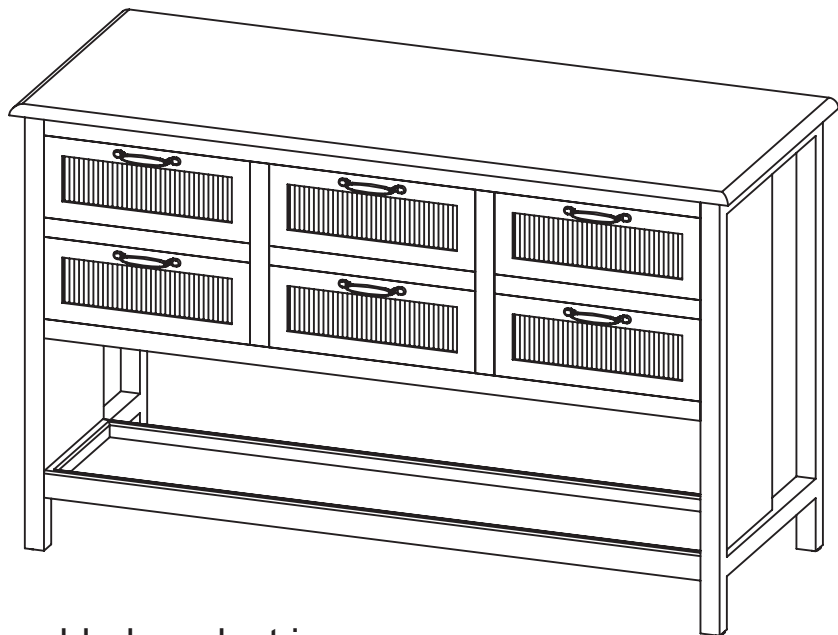

Note: If the assembled product is uneven, this can be resolved by adjusting the feet.

Your kitchen Island is ready for use.