

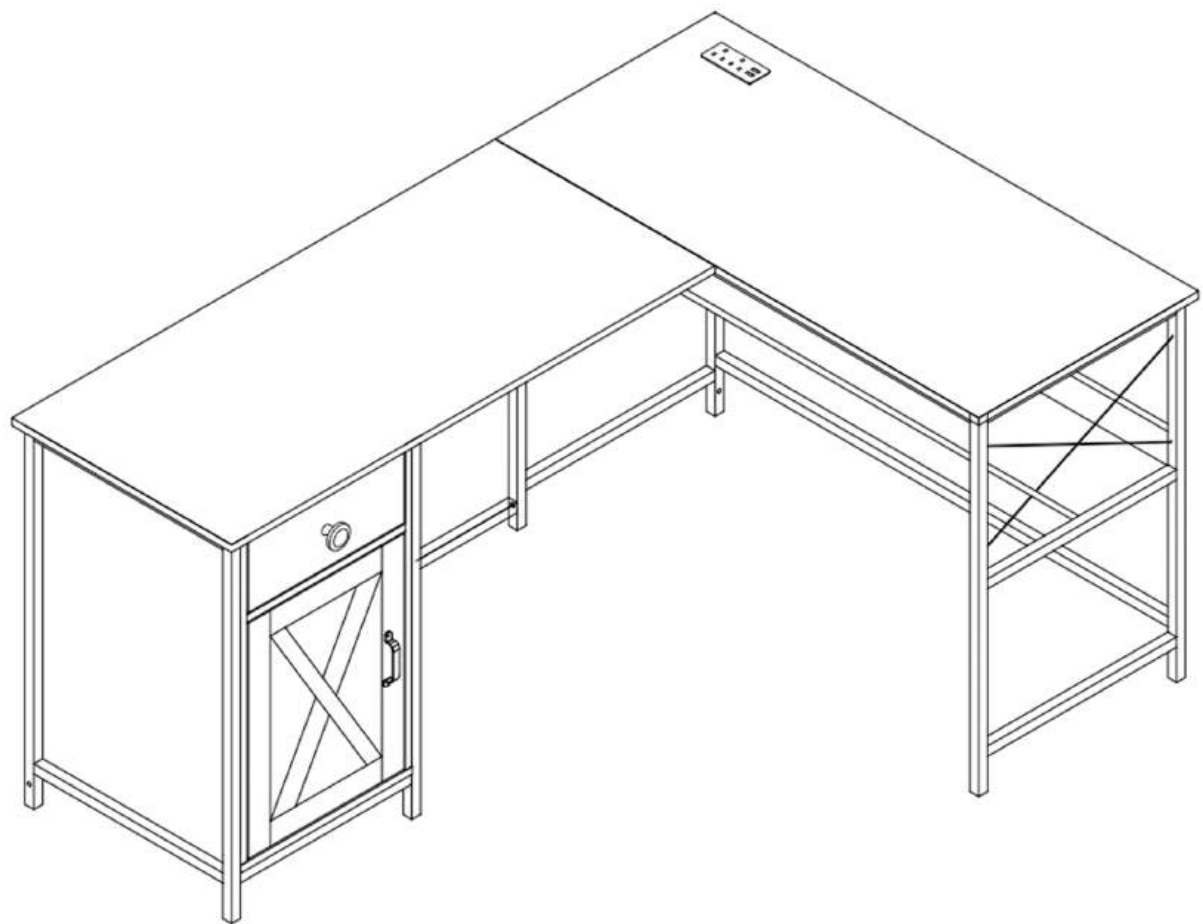

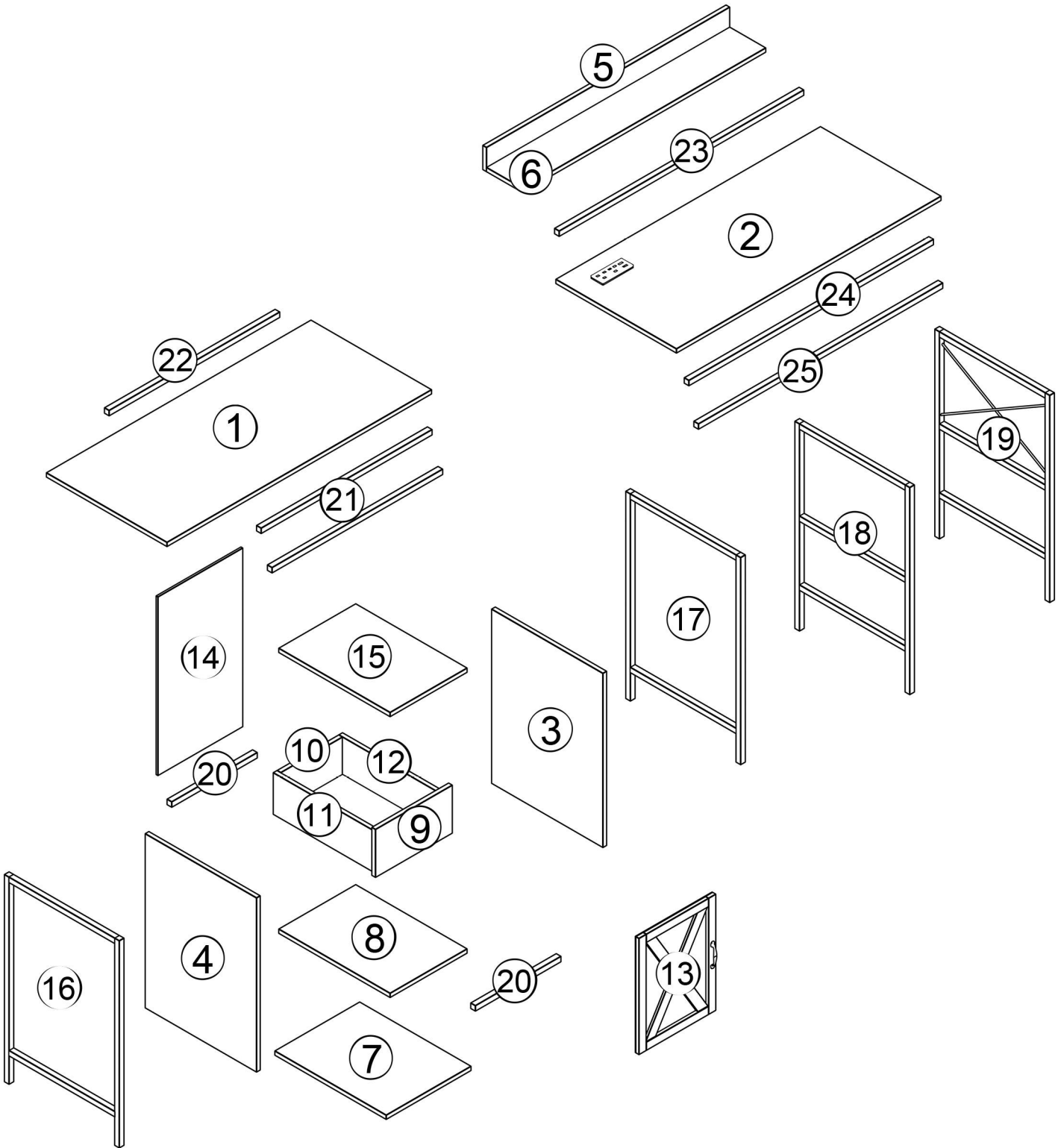

**USER'S MANUAL**  
**Farmhouse Office Desks**  
**SKU: H00054**



# Boad Identification

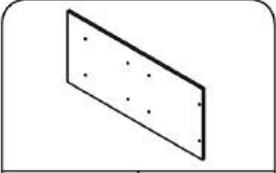
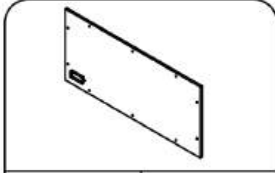
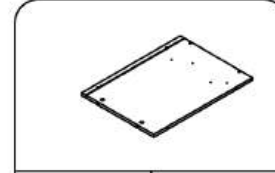
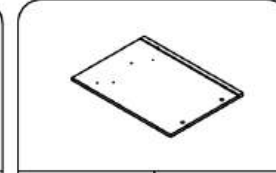
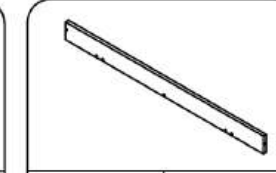
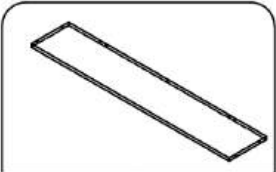
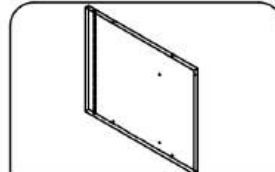
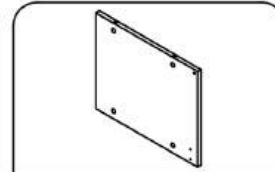
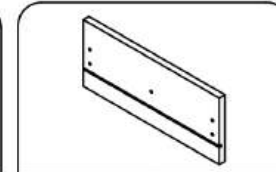
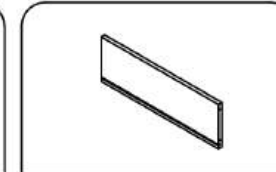
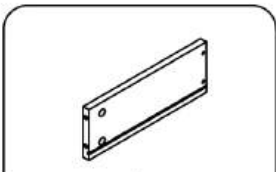
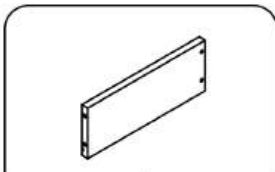
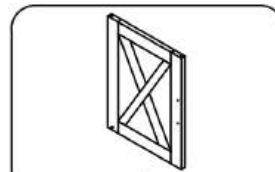
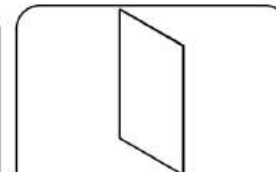
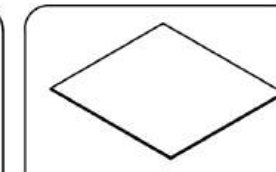
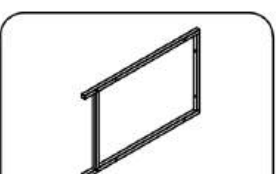

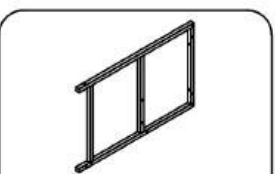
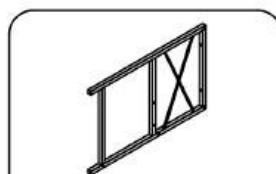
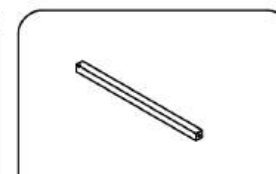
# Parts List

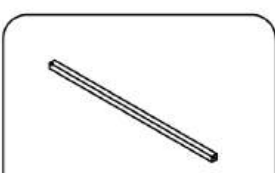
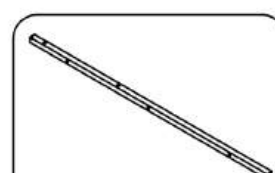
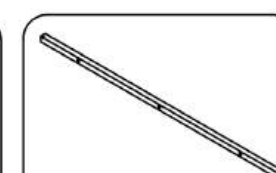
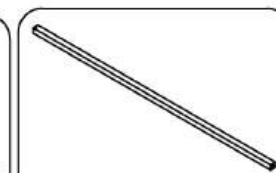
				
1   1PC	2   1PC	3   1PC	4   1PC	5   1PC
				
6   1PC	7   1PC	8   1PC	9   1PC	10   1PC
				
11   1PC	12   1PC	13   1PC	14   1PC	15   1PC
				
16   1PC	17   1PC	18   1PC	19   1PC	20   2PC
				
21   2PC	22   1PC	23   1PC	24   1PC	25   1PC

# Hardware List



A 12PC



φ15

B 12PC



φ8\*30mm

C 2PC



Ø4\*40mm

D 7PC



E 1PC



M4\*22mm

F 3PC



φ3.5\*14mm

G 8PC



M6\*30mm

H 32PC



M6\*50mm

I 16PC



J 1PC



K 1PC



L 2PC



M 1PC



N 1PC

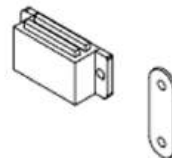

O 1PC



φ3\*14MM

P 6PC



Q 1PC

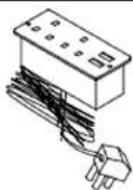

R 1PC

## REPLACEMENT PARTS

We are devoted to provide the best products and services for customers. Please contact us via the “**Contact seller**” button in the detail page of your order for any concern and we'll response as soon as possible.

# STEP 1

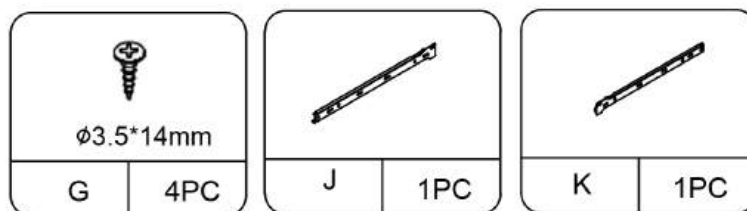

Attach rails (K) to part (3) through screws (G).

Attach rails (J) to part (4) through screws (G).

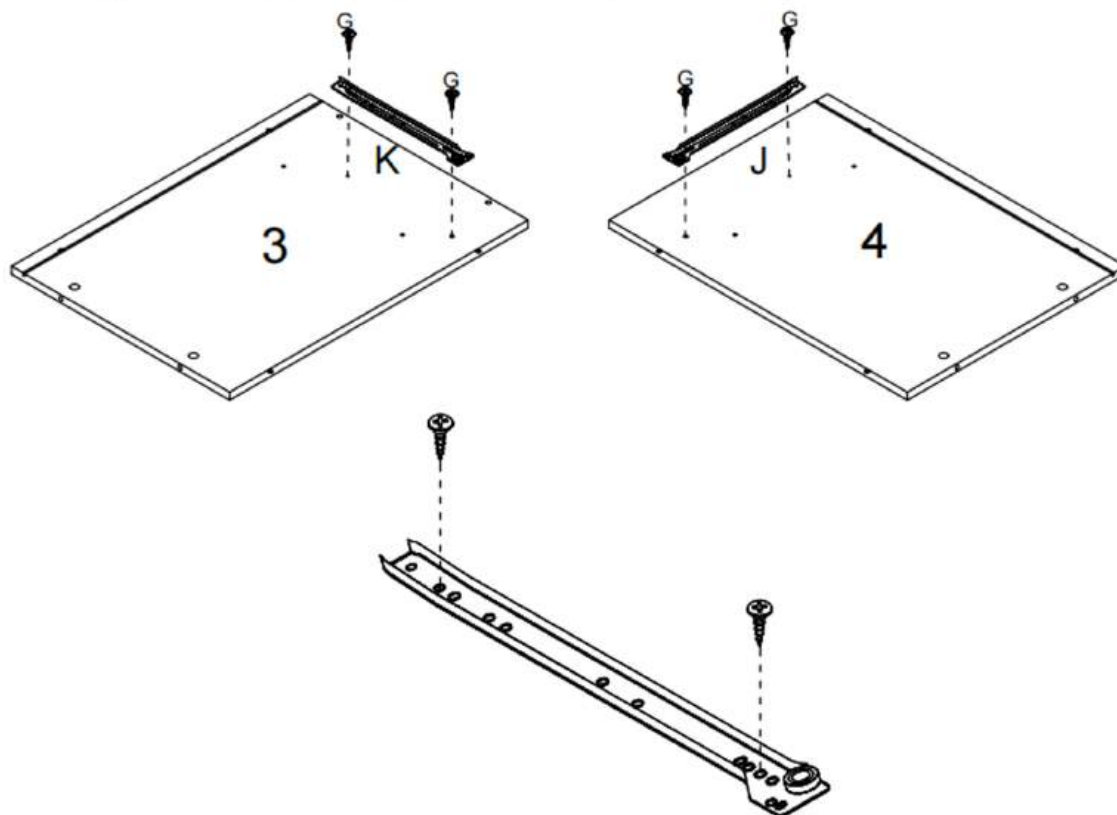

# STEP 2

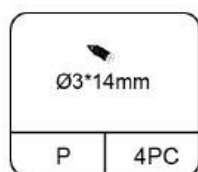
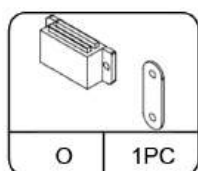

Attach part (O) to part (13) with screw (P).

Attach part (O) to part (8) with screw (P).

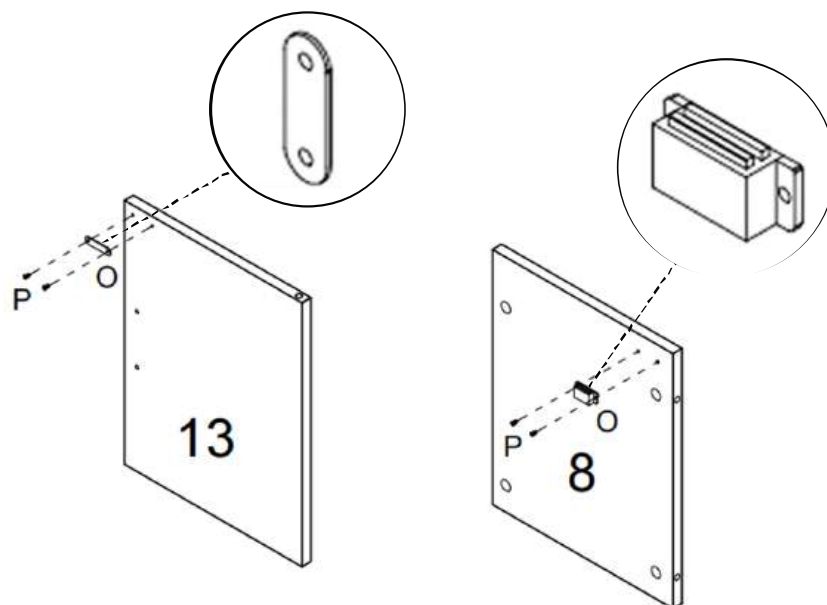

# STEP 3

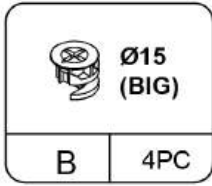
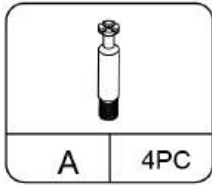

Insert dowel (A) into parts (3,4) through screwdriver.  
Attach parts (3,4) to part (8) through dowel (A).

Insert and secure cam lock (B) into part (8) to lock part (3,4).

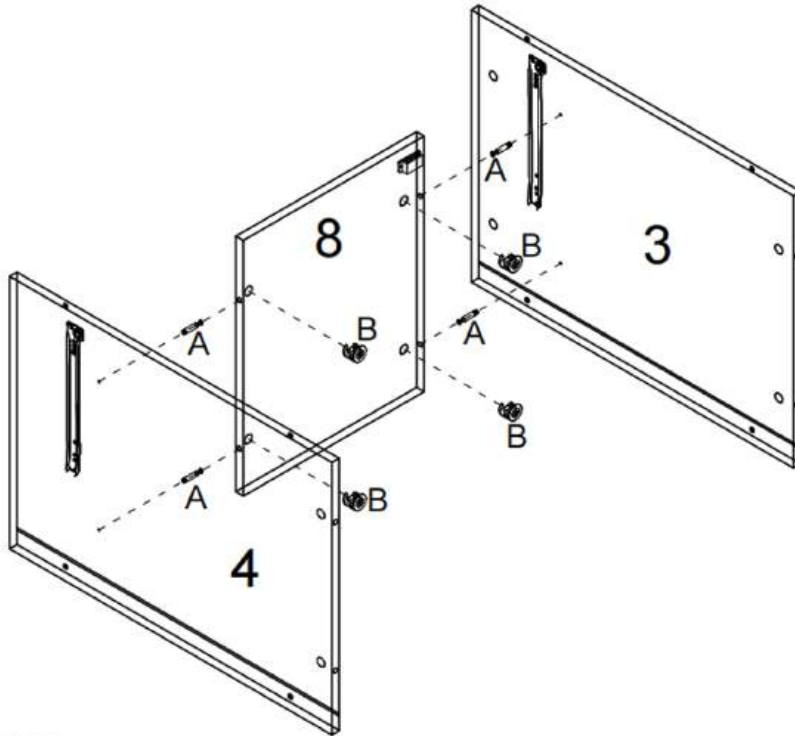

Be careful not to over tighten



# STEP 4

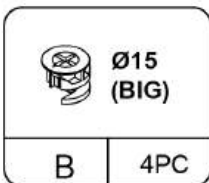
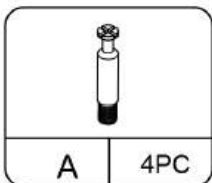

Arrow on lock(B) should point in the direction of bolt (A).

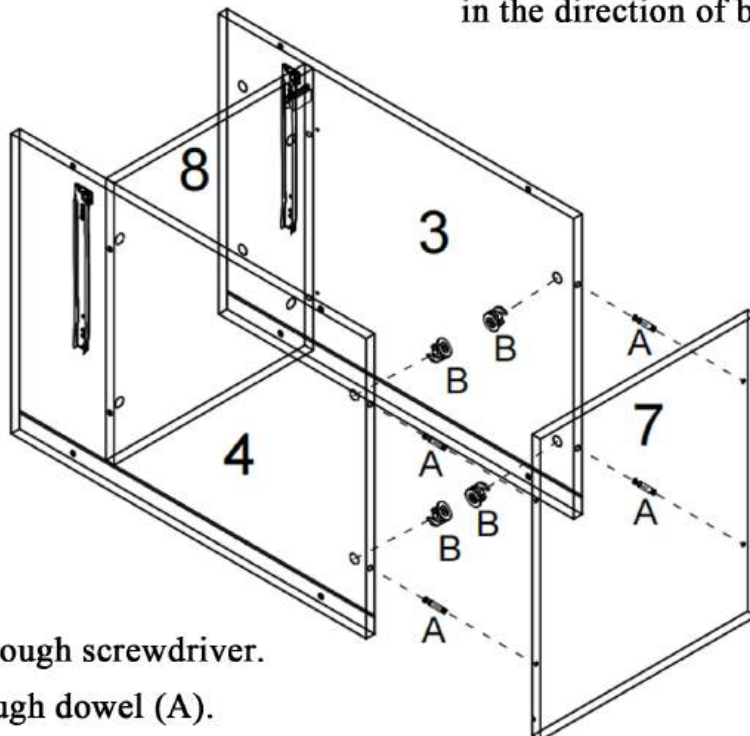

Insert dowel (A) into parts (7) through screwdriver.

Attach part (7) to parts (3,4) through dowel (A).

Insert and secure cam lock (B) into part (3,4) to lock part (7).

# STEP 5

---

Slide back panel (14) into groove of parts (3,4) as per diagram.

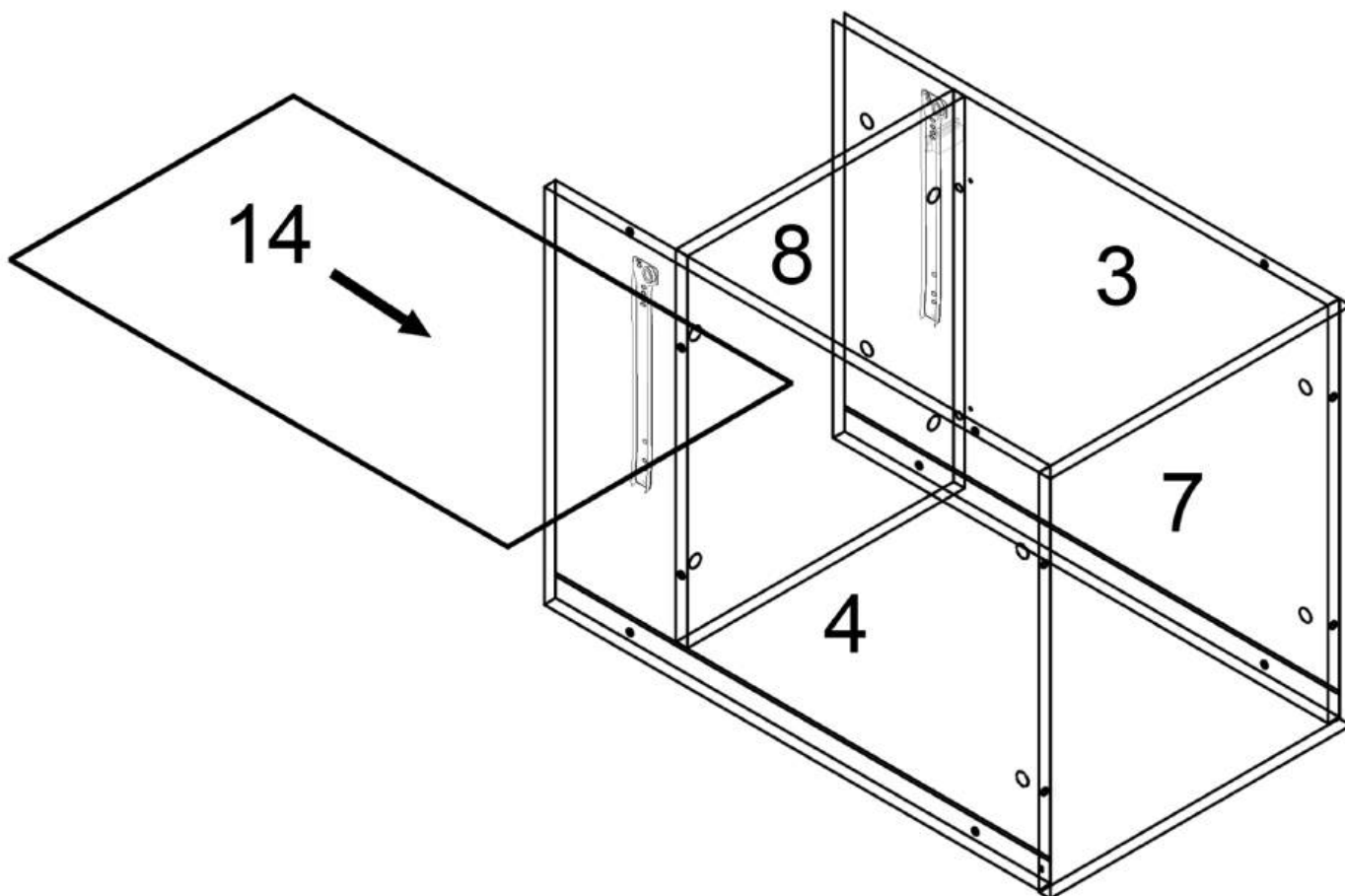

# STEP 6

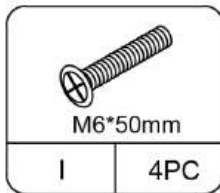
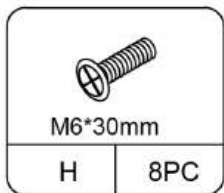

Attach steel tube (20) to parts (16,17) through screws (I).  
Insert screw (H) to part (16) to lock part (4) with screwdriver.  
Insert screw (H) to part (17) to lock part (3) with screwdriver.

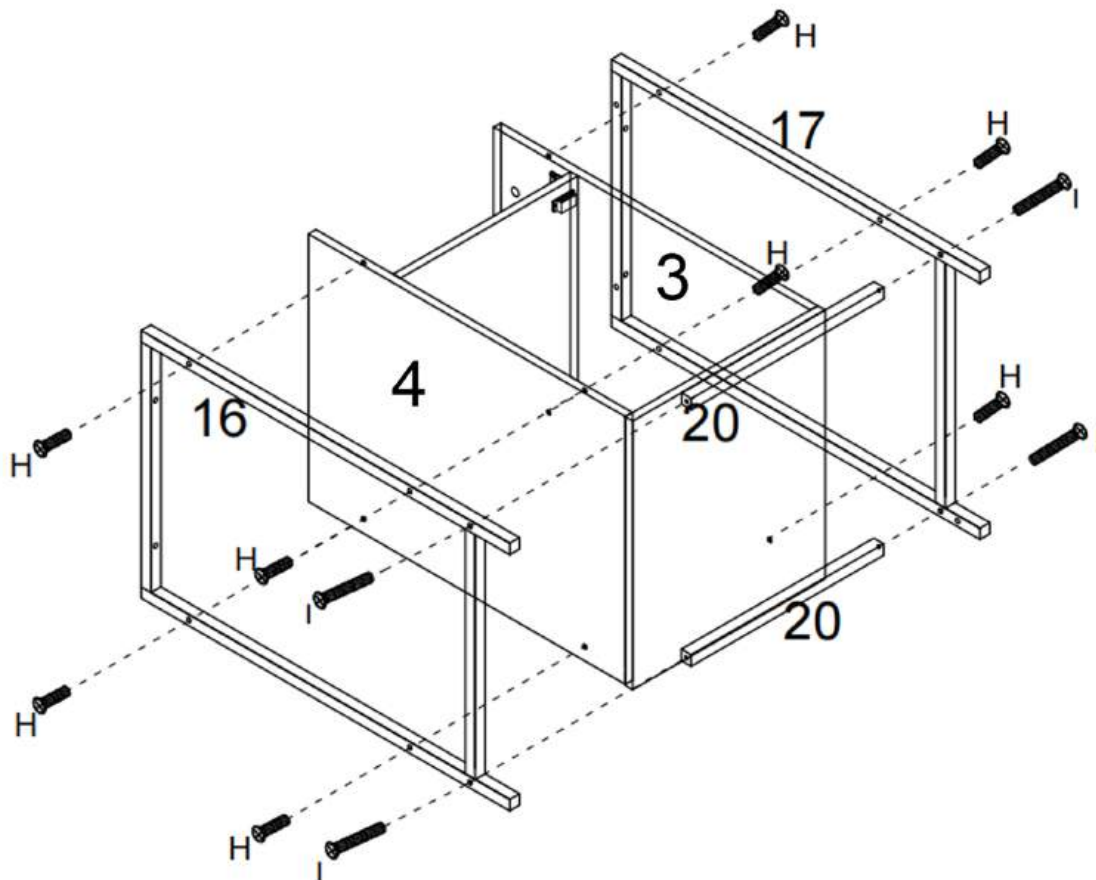

# STEP 7

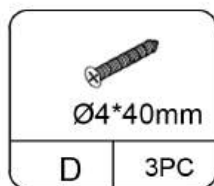
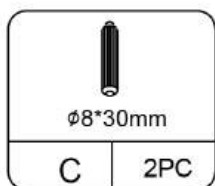

Attach part (5) to part (6) through screws (D) and dowel (C).

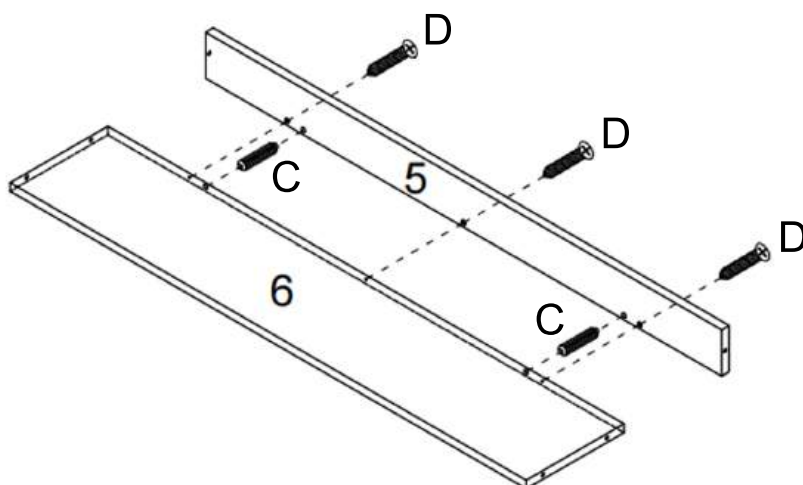

# STEP 8

---

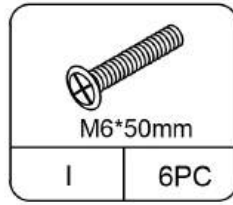
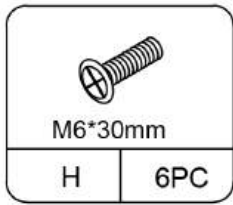

Attach steel parts (5,6) to parts (18,19) through screws (H).

Attach steel tube (23) to parts (18,19) through screws (I).

Attach steel tube (24) to parts (18,19) through screws (I).

Attach steel tube (25) to parts (18,19) through screws (I).

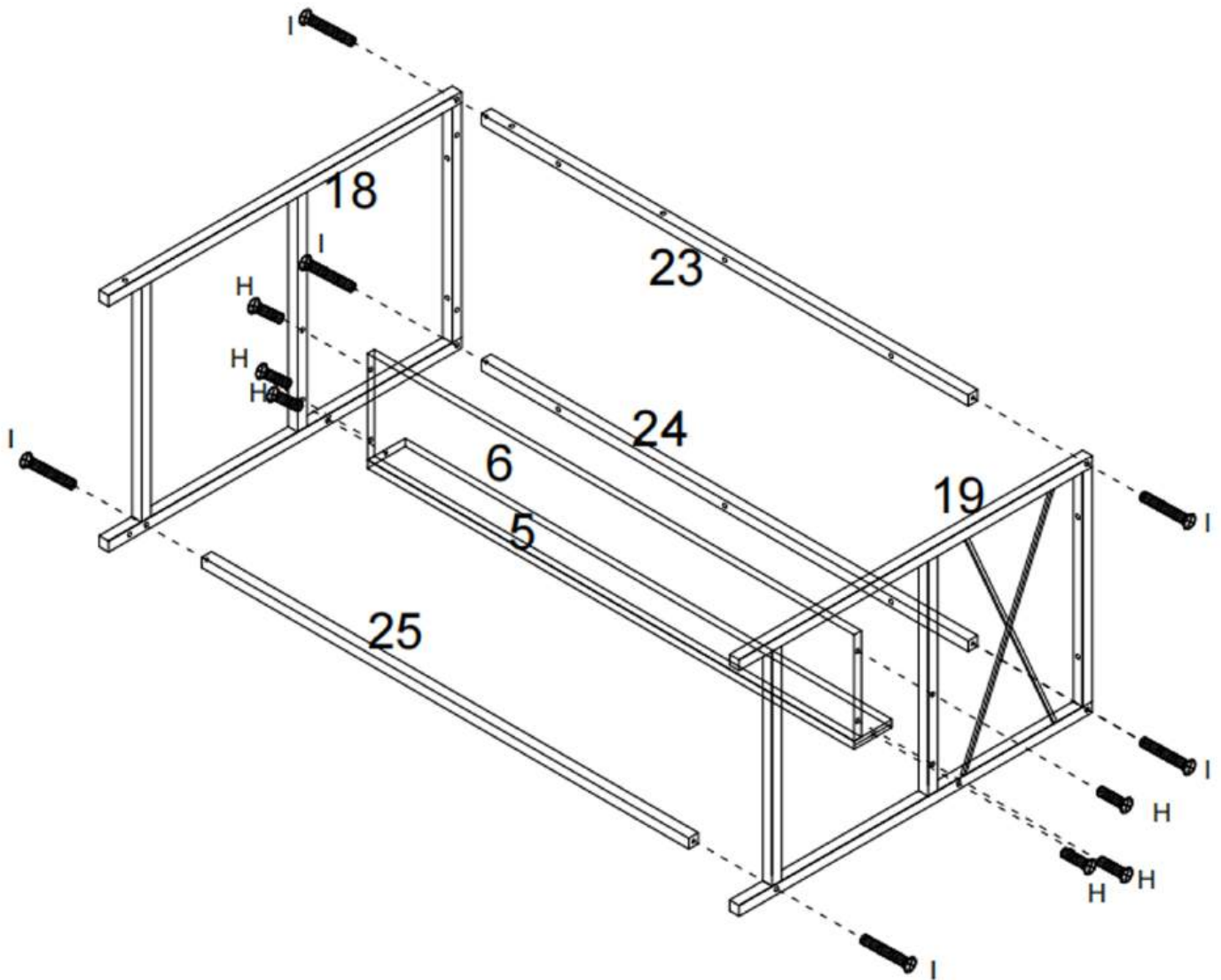

# STEP 9

---

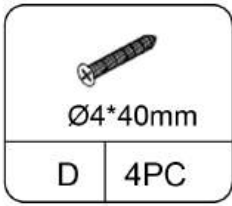

Insert screw (D) to parts (11,12) to lock part (10) with screwdriver.

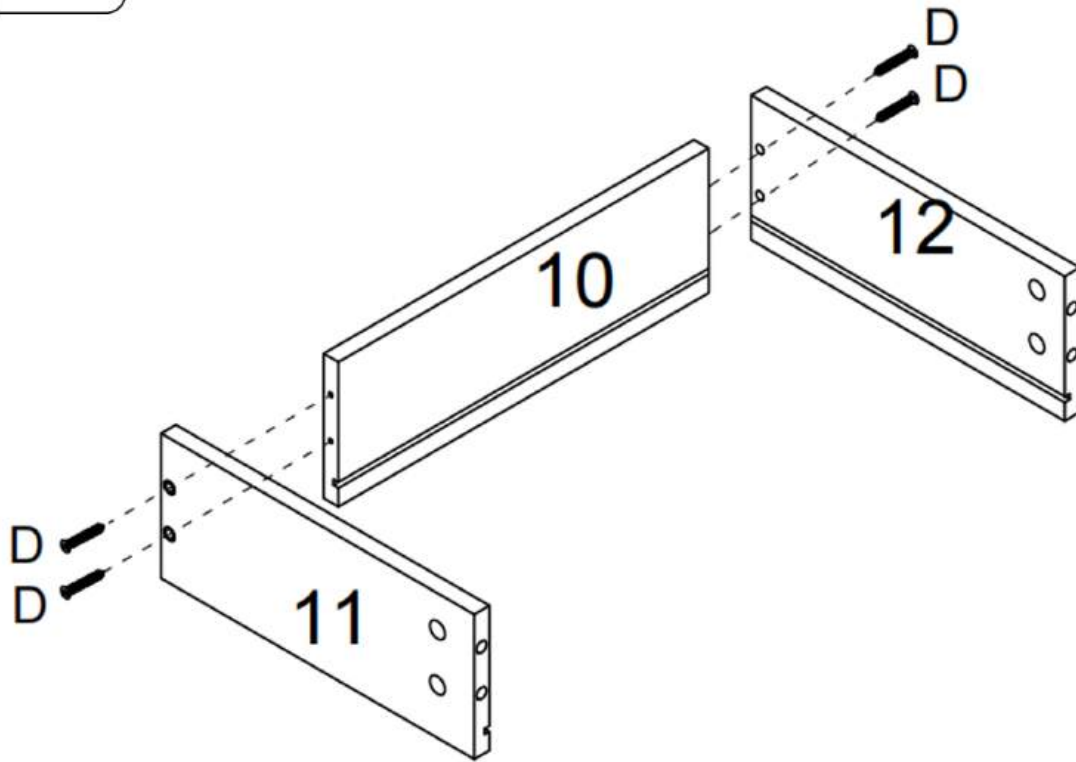

# STEP 10

---

Slide part (15) into groove of parts (11,12) as per diagram.

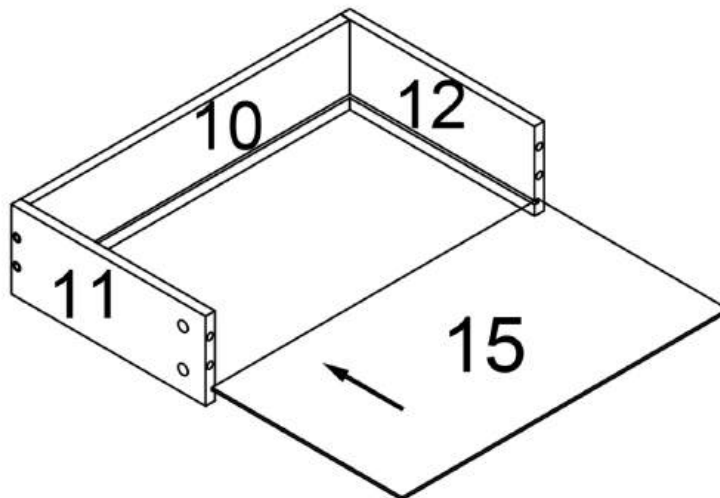

# STEP 11

---

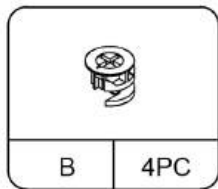
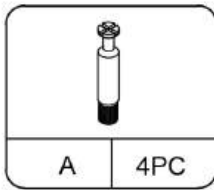

Insert dowel (A) into part (9) through screwdriver.

Attach part (9) to parts (11,12) through dowel (A).

Insert and secure cam lock (B) to part (11,12) to lock part (9).

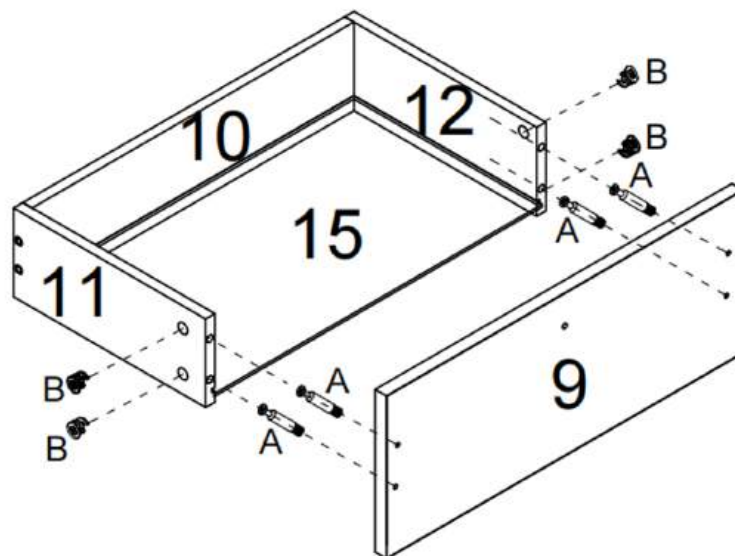

# STEP 12

---

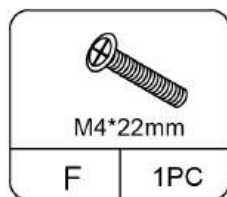
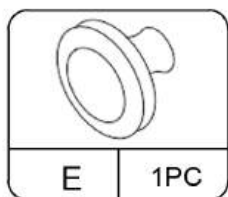

Attach handle (E) to part (9) using screw (F) with screwdriver.

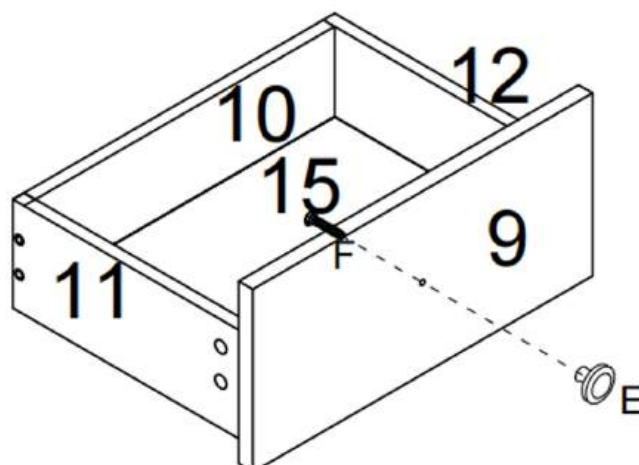

# STEP 13

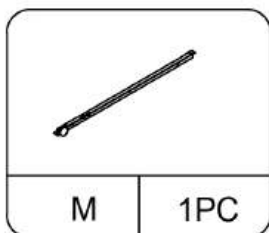
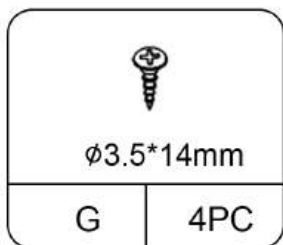
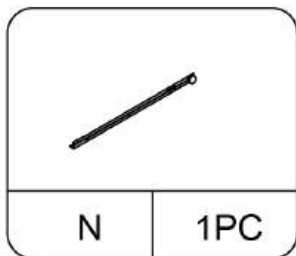

Attach rail (M,N) on the bottom of the drawer through screw (G).

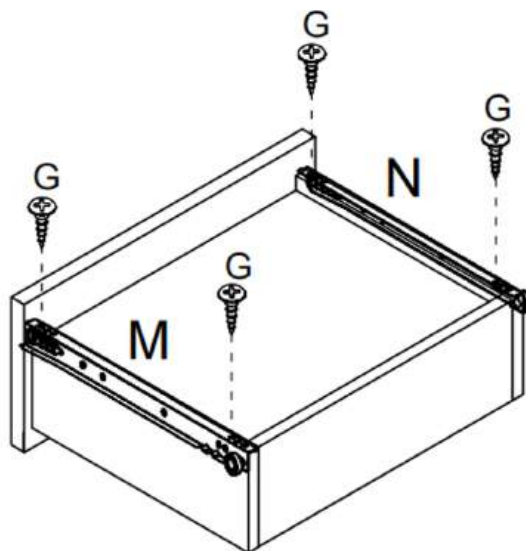

# STEP 14

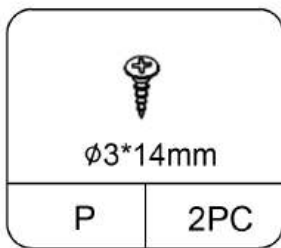
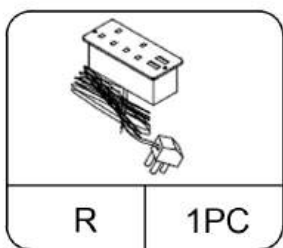

Attach part (R) to part (2) through screw (P).

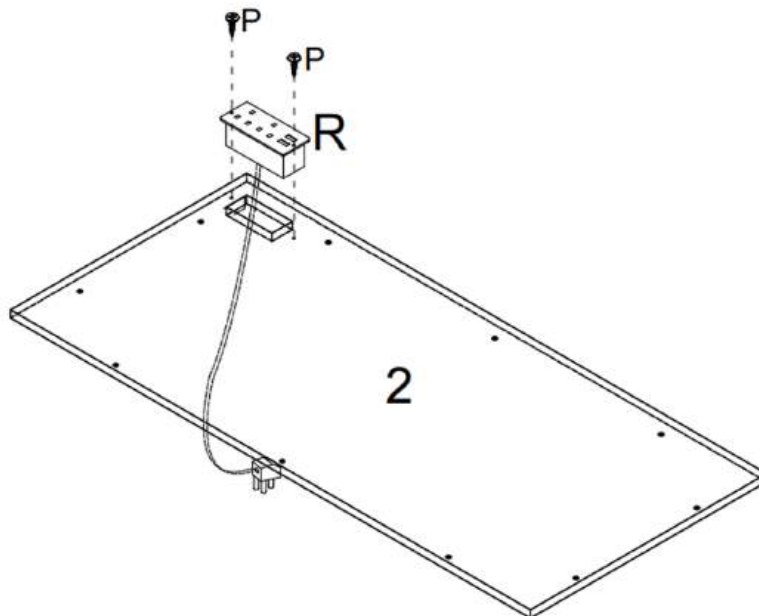

# Two Assembly Methods

## First Method: L-shaped Desk Assembly Method

### STEP 1

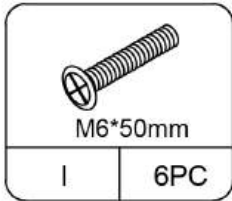

Attach steel tube (21,22) to parts (17,23) through screws (I).

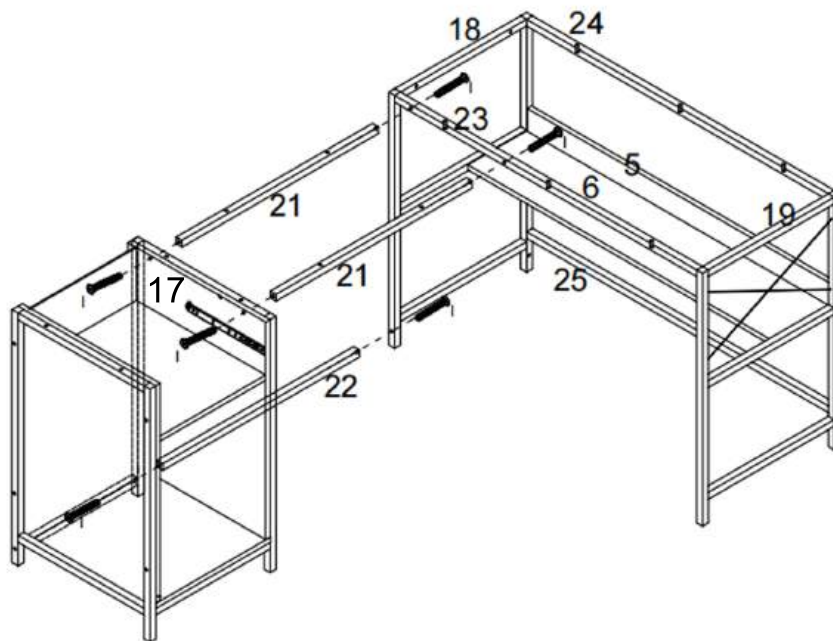

### STEP 2

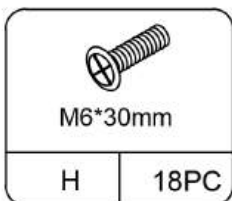

Attach Top board (1,2) to table body through screw (H) as per diagram.

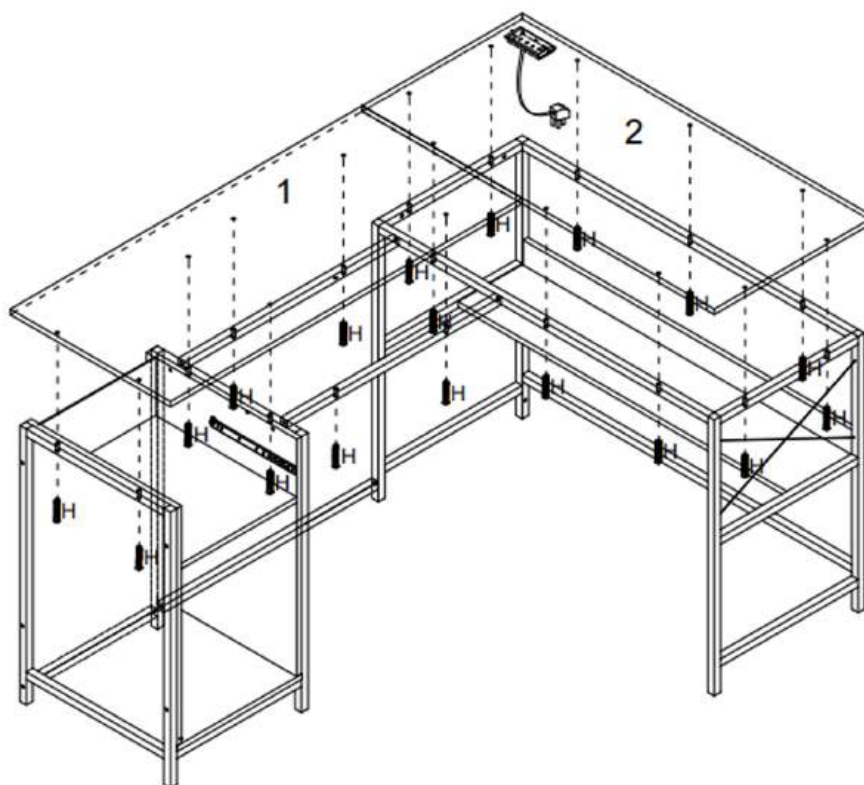

# STEP 3

Push the roller in the direction of the arrow as per diagram, and the drawer can easily slide into the guide rail to complete the installation.

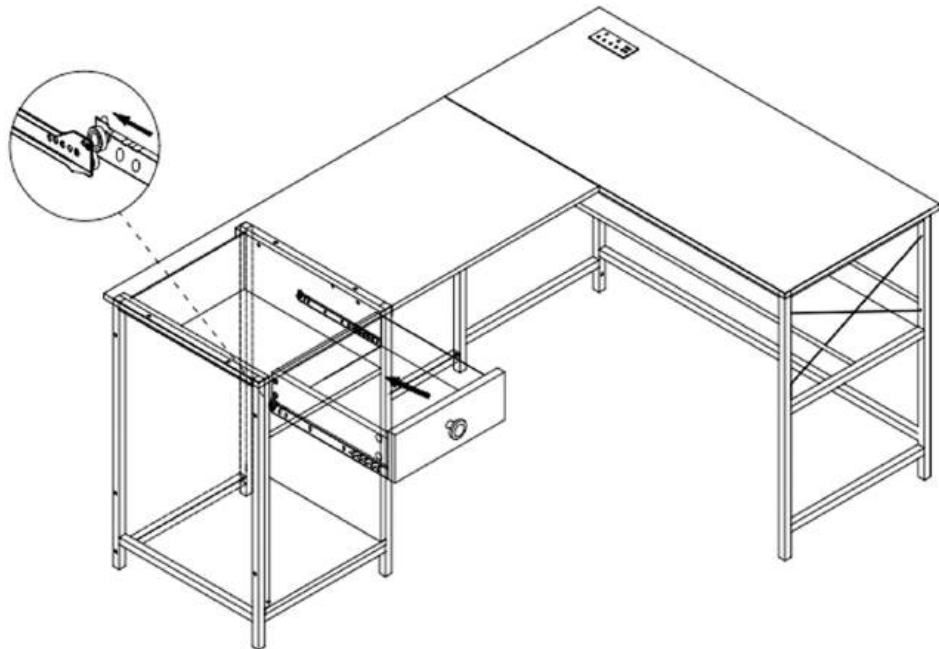

# STEP 4

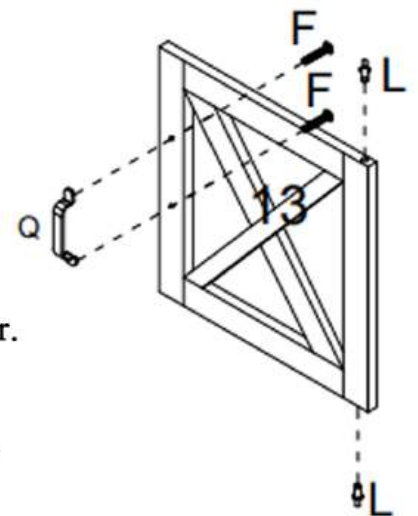
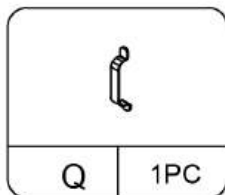
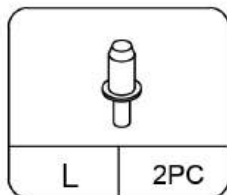
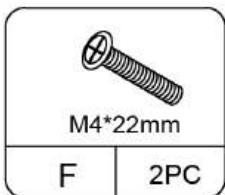

Attach handle (Q) to part (13) using screw (F) with screwdriver.

Insert part (L) into part (13).

Attach part (13) to board (7,8) through part (L) as per diagram.

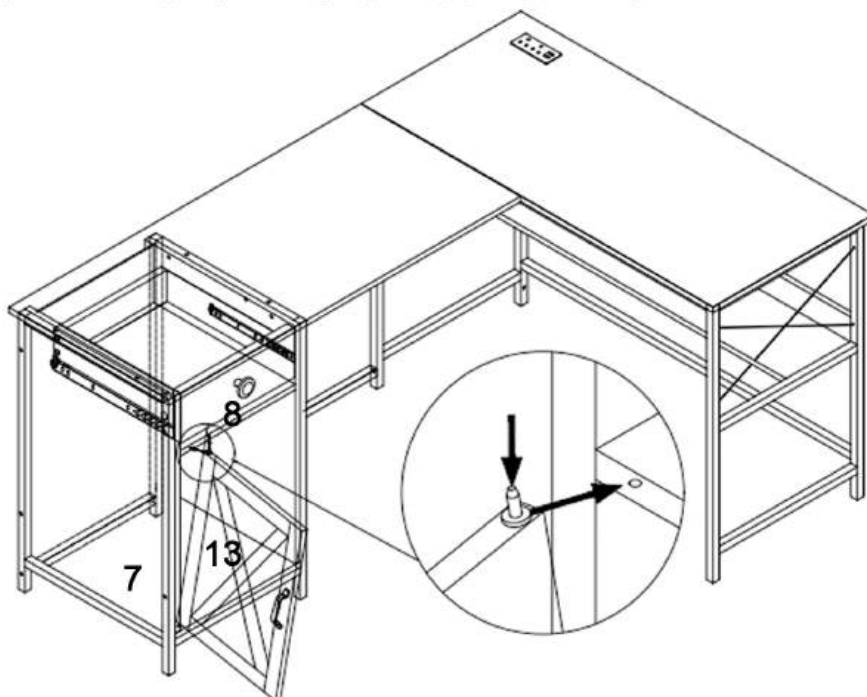

# Second Method: Long Desk Assembly Method

## STEP 1

---

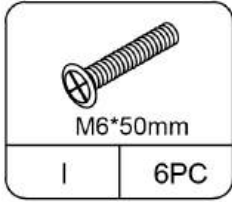

Attach steel tube (21,22) to parts (17,23) through screws (I).

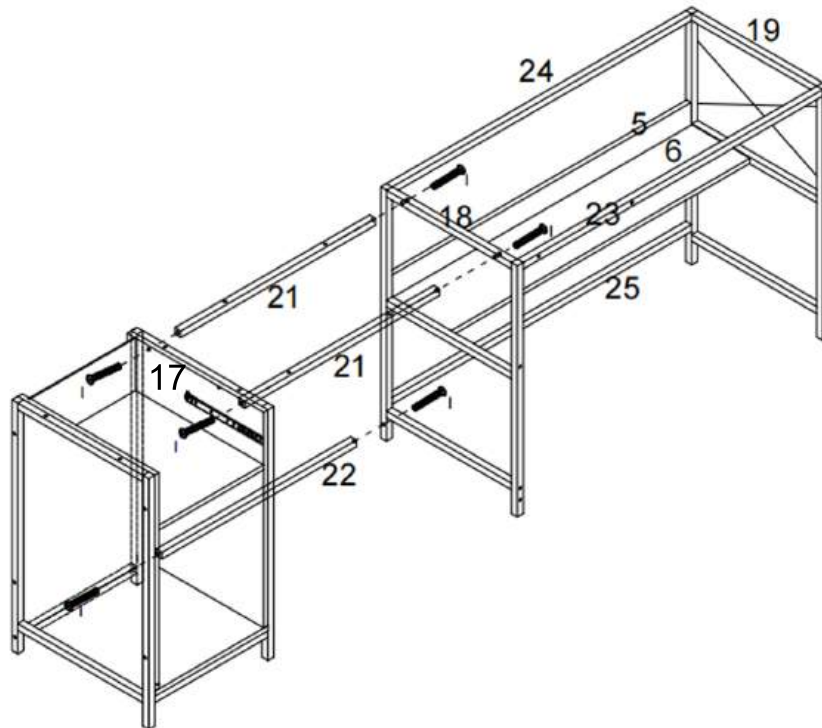

## STEP 2

---

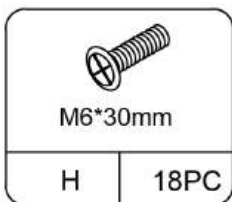

Attach Top board (1,2) to table body through screw (H) as per diagram.

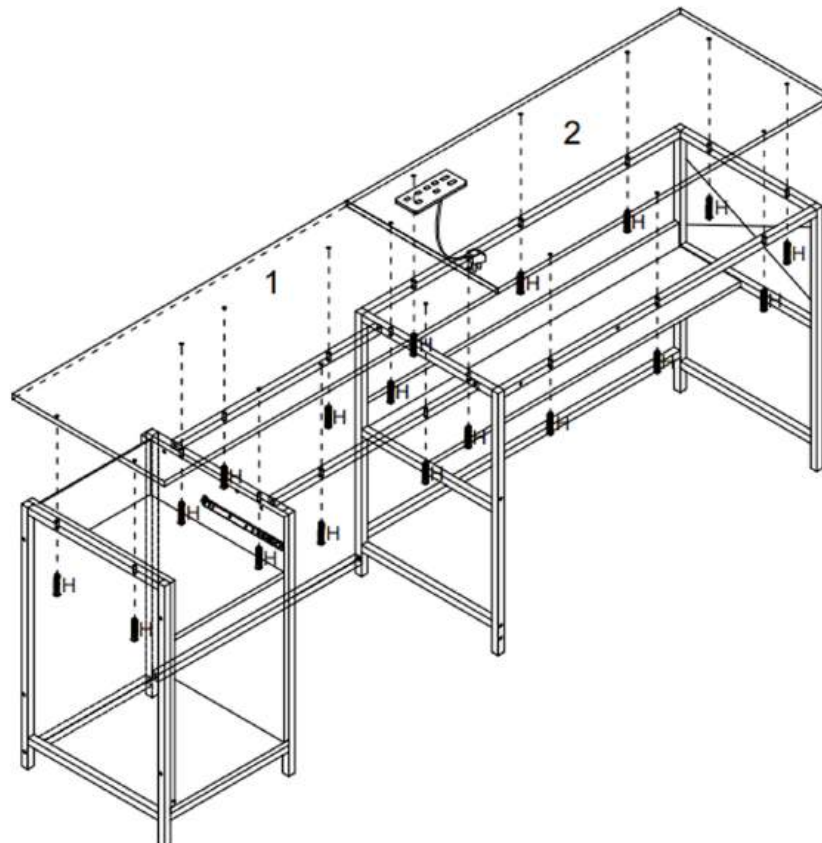

# STEP 3

Push the roller in the direction of the arrow as per diagram, and the drawer can easily slide into the guide rail to complete the installation.

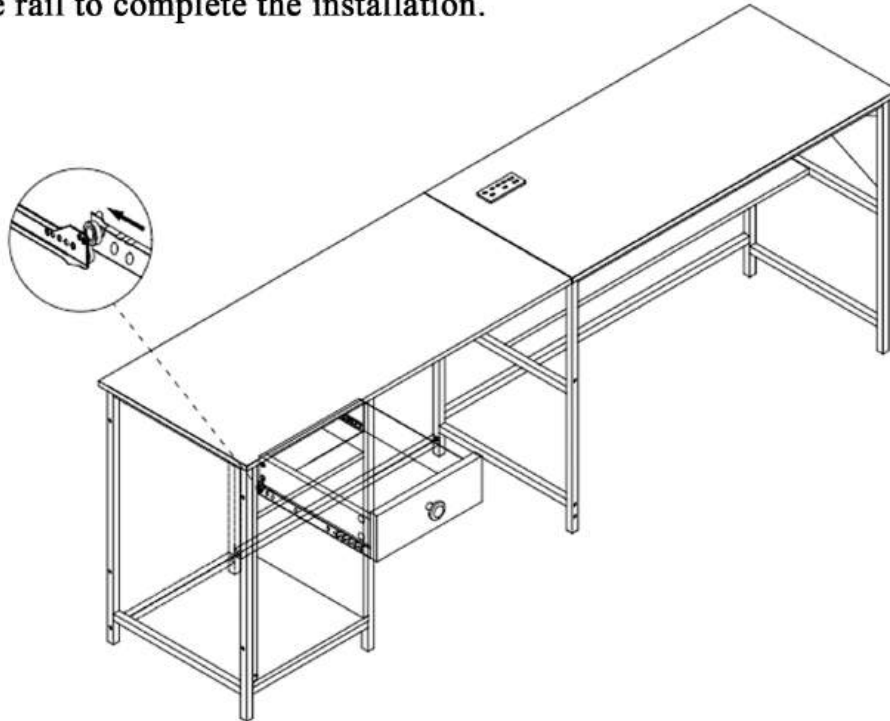

# STEP 4

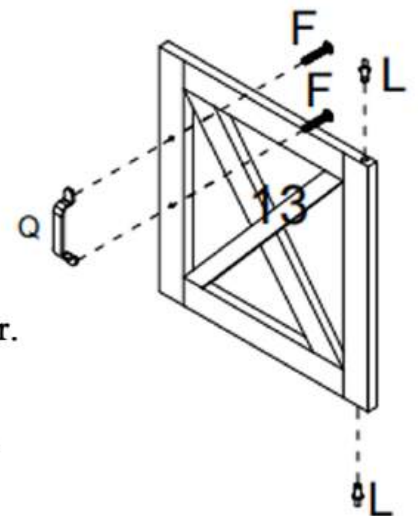
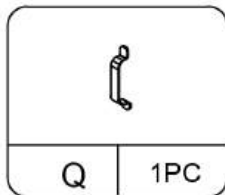
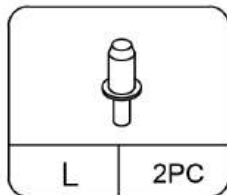
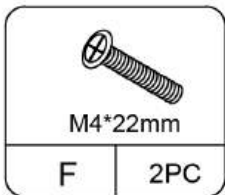

Attach handle (Q) to part (13) using screw (F) with screwdriver.

Insert part (L) into part (13).

Attach part (13) to board (7,8) through part (L) as per diagram.

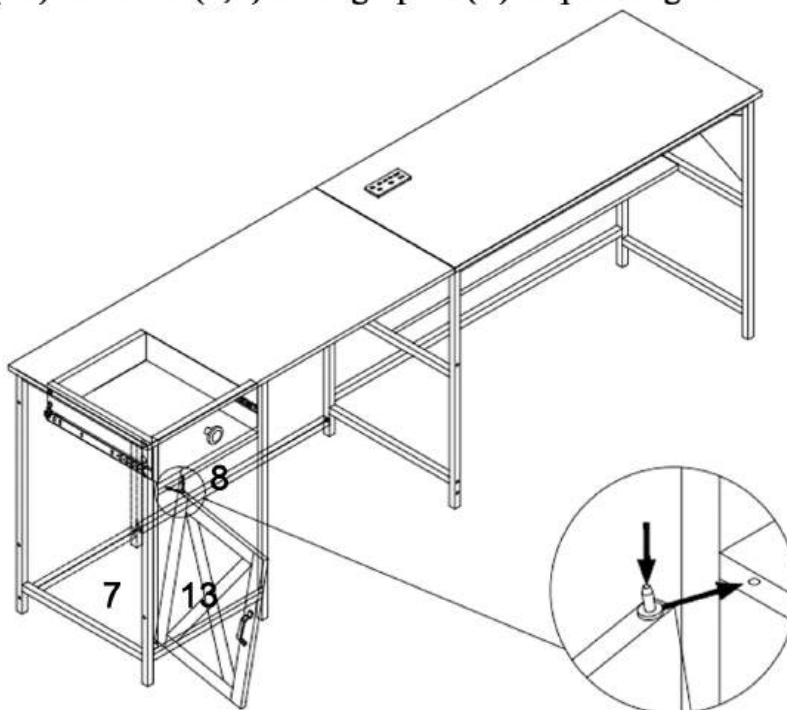

## L-shaped Desk Installation Display

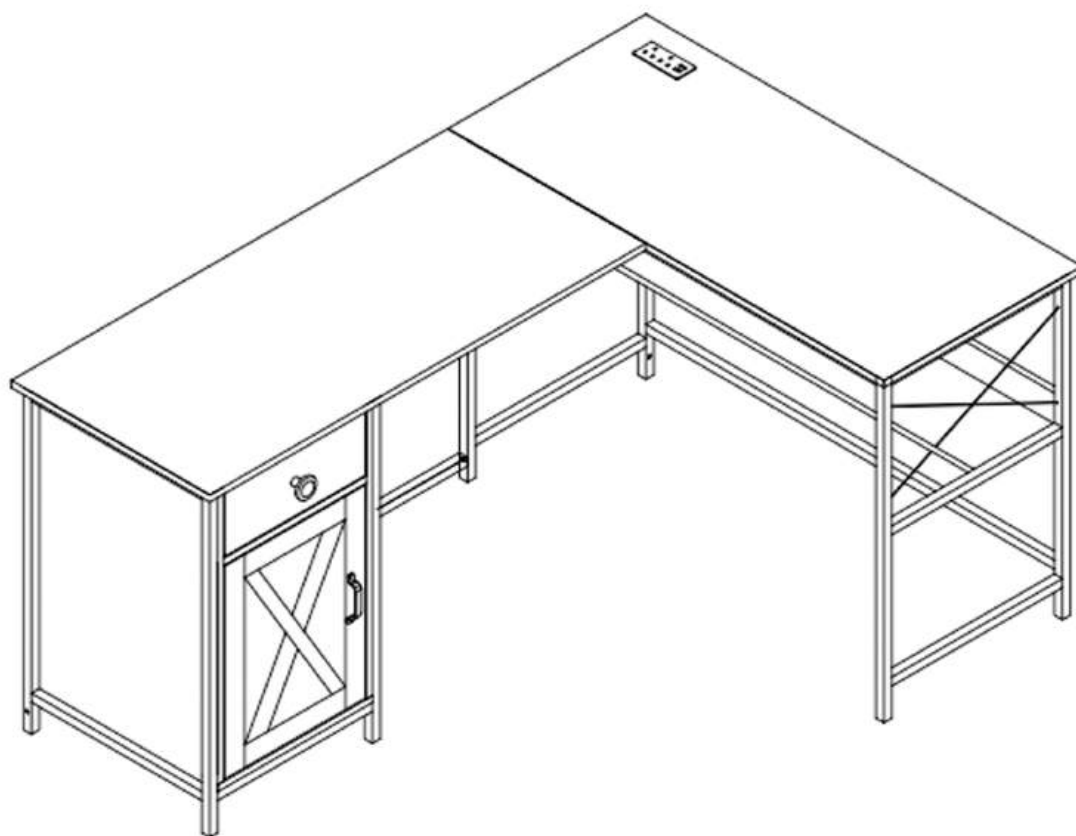

## Long Desk Installation Display

