

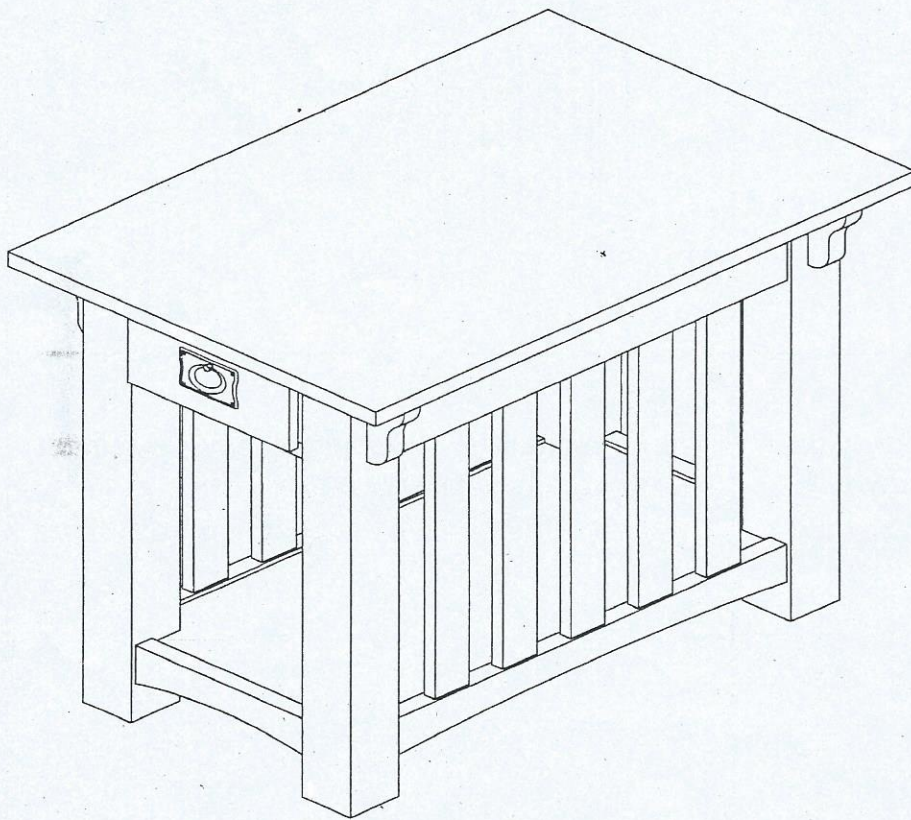









Assembly Instructions, End Table



A: Top Assembly	
B: (2) Side Frames	
C: Shelf	
D: (4) Long Bolts	
E: (8) Lock Washers	
F: (8) Flat Washers	
G: Allen Wrench	
H: (4) Short Bolts	
I: (4) Corbels	

Step 1

Place the top assembly (A) upside down on a soft surface and then open the drawer.

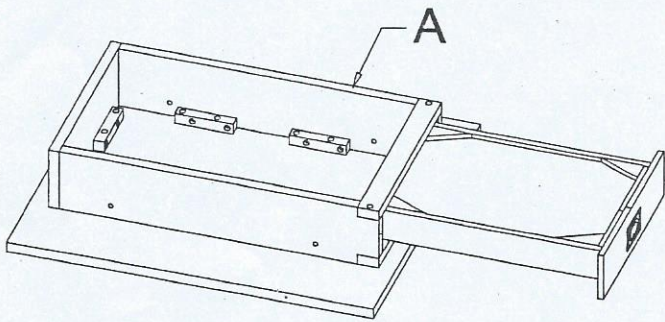

Step 2

Align the threaded holes in the legs with the holes on the aprons. Secure in place with the long bolts (D), flat washers (F) and lock washers (E) using the Allen wrench (G).

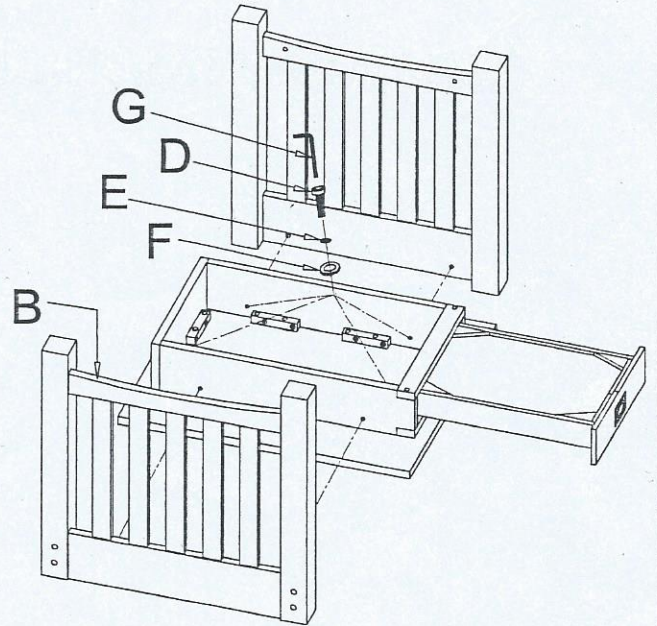

Step 3

Attach the shelf (C) to the side panel with the short bolts (H), flat washers (F) and lock washers (E) using the Allen wrench (G).

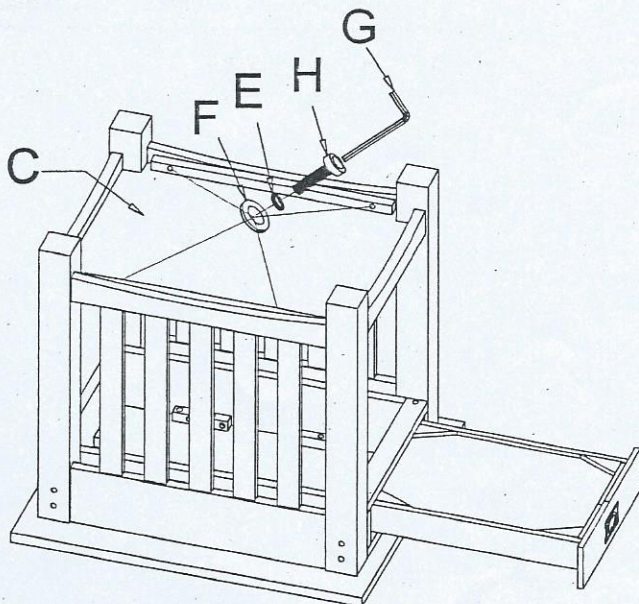

Step 4

Set the assembled table upright, and then attach the corbels (I) to the side frames.

