



166 Bottle Wine Cabinet Manual

We know you don't want to read through this manual, but trust us, there is good information in here.

IMPORTANT SAFETY PRECAUTIONS



To reduce the risk of fire, electrical shock, or injury when using your appliance, follow these basic precautions:



IF YOU READ NOTHING ELSE IN THIS MANUAL, PLEASE READ THIS

Risk of child becoming trapped in wine cooler, beverage cooler, other refrigeration unit, or large boxes.

Junked or abandoned appliances, boxes and other containers are still dangerous, even if they will “just sit in the garage for a few days”.

Do the following before you throw away your old wine cooler, beverage cooler or refrigeration unit:

1. Take off the door.
2. Leave the shelves in place so that children cannot climb inside.

Never allow children to operate, play with, or crawl inside the appliance.

Never clean appliance parts with flammable fluids. The fumes can create a fire hazard or explosion.

Do not store in the vicinity of any other appliance. Do not store near gasoline or any other flammable vapors. The fumes can create a fire hazard or explosion.

Save these instructions.

What's in the box?

- Instruction manual
- 15 Pull-out shelves
- 2 Keys
- 1 Handle
- Hardware for door (top and bottom hinges, screws to reverse the door swing)
- Spare parts (hopefully you won't need these)

I received my wine cabinet, now what?

- Your wine cabinet was designed to be built into kitchen or bar cabinets or it will work just fine as a standalone appliance. Your choice.
- You should place your wine cabinet on a flat, solid floor that is strong enough to support it when it is fully loaded (300-700 lbs.). To level your wine cellar, adjust the front leveling leg at the bottom of the wine cabinet.
- Locate the wine cabinet away from direct sunlight and sources of heat (stove, heater, radiator, etc.). Direct sunlight may affect the UV coating on your glass door extreme heat or cold will also cause the unit to perform improperly.
- Avoid locating the wine cabinet in damp areas.
- Plug the wine cabinet into a dedicated (for this appliance only), properly installed and grounded wall outlet. Do not under any circumstances cut or remove the third (grounding) prong from the power cord. Any questions concerning power and/or electrical grounding should be directed to a certified electrician or authorized product service center.
- Install handle on door

Handle Installation:

Install the door handle provided with the appliance by following these steps:

1st Step - Remove the gasket on the internal Flat Washer door to expose the two screw holes.

2nd Step - Install the handle with the screws and washers provided.

3rd Step - Restore the gasket.

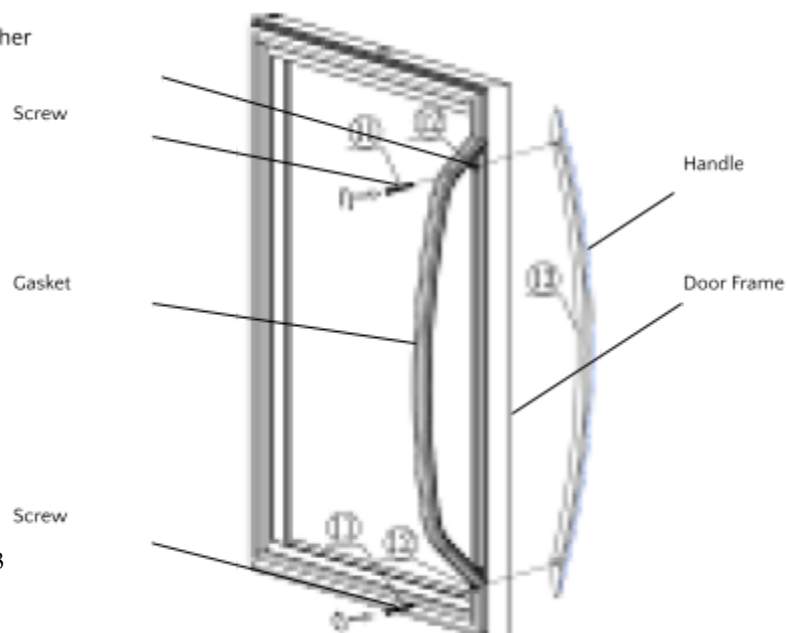

Installation instructions for built in application

166 Bottle

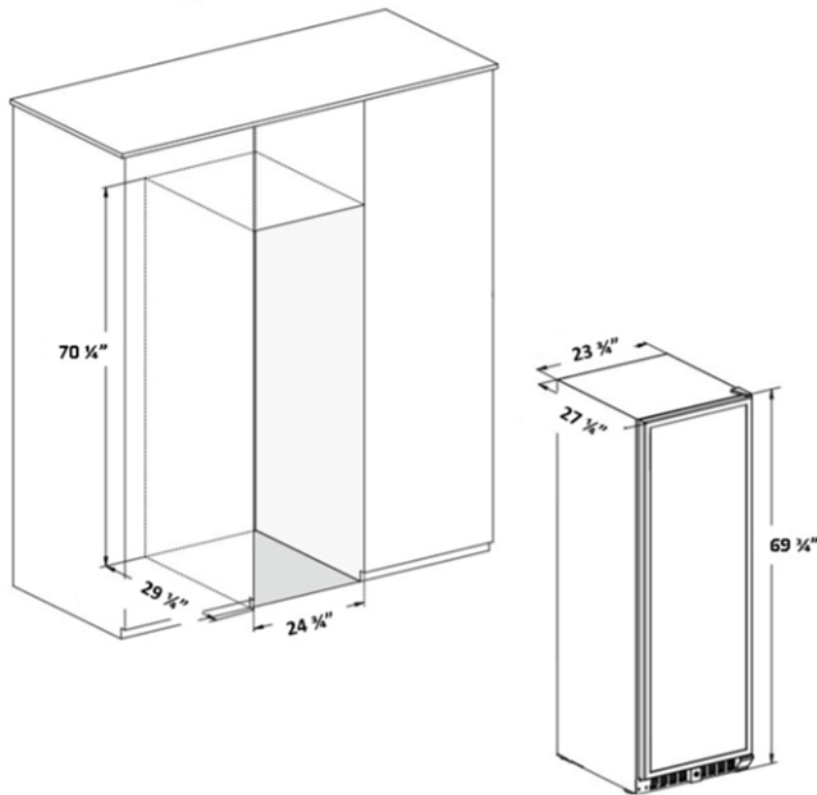

My wine cabinet is plugged in; how do I use it? The control panel:

Single Zone:

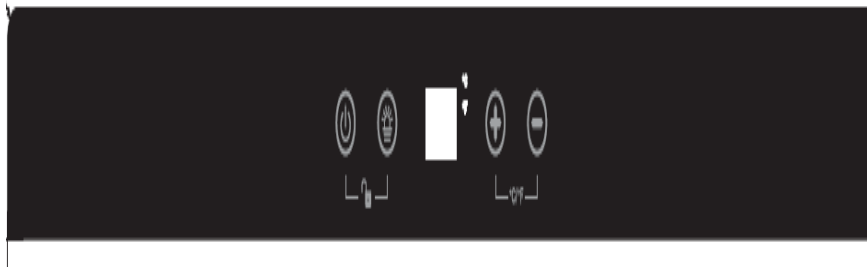

The control panel of your wine refrigerator has a safety feature that prevents someone from accidentally changing the temperature or shutting the appliance off. If left untouched for 10 seconds, the control panel will lock and be unresponsive to touch. To unlock your wine refrigerator, press both power and light at the same time and hold for 5 seconds. The display will unlock and allow you to change the temperatures and turn the lights on or off. Leave the display

alone for 10 seconds and it will return to a locked state.



On/off switch for wine refrigerator



On/off switch for interior light



Increase temperature by 1 degree



Decrease temperature by 1 degree



Press both degree up and degree down buttons at the same time and hold for 5 seconds to change the display temperature from Fahrenheit to Celsius

Dual Zone:

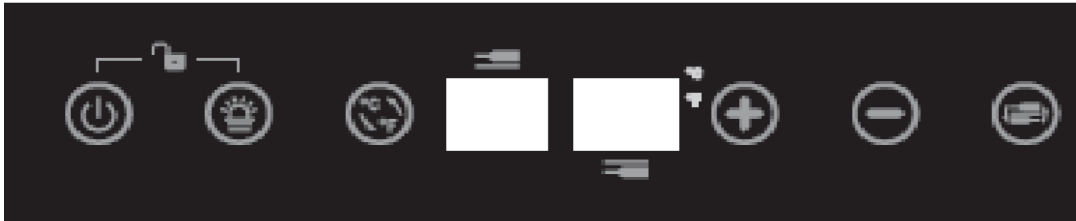

On/off switch for refrigerator



On/off switch for refrigerator



Increase temperature by 1 degree



Decrease temperature by 1 degree



The control panel of your wine refrigerator has a safety feature that prevents someone from accidentally changing the temperature or shutting the appliance off. If left untouched for 10 seconds, the control panel will lock and be unresponsive to touch. To unlock your wine refrigerator, press both power and light at the same time and hold for 5 seconds. The

display will unlock and allow you to change the temperatures and turn the lights on or off. Leave the display alone for 10 seconds and it will return to a locked state.



Press to change display from Fahrenheit to Celsius



Press to adjust different temperature zones

Reversing the Door Swing of Your Appliance

Before you begin: Tape down shelves to avoid movement during the process

- The unit may have been delivered to you with the door opening from the left side (hinges on the right).
- The door of this appliance can be hung to open on the left or right side. To reverse the door swing of your cellar and open from the opposite side, please follow the instructions and diagram below.

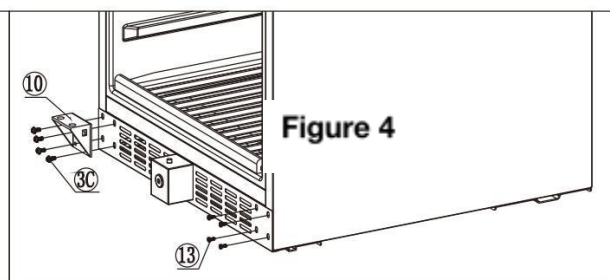
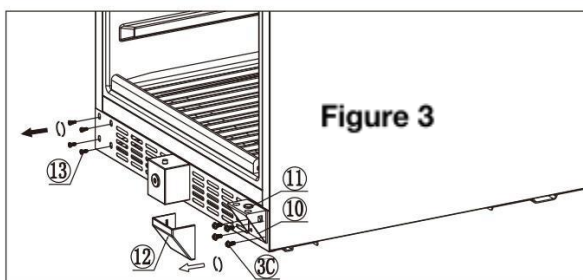
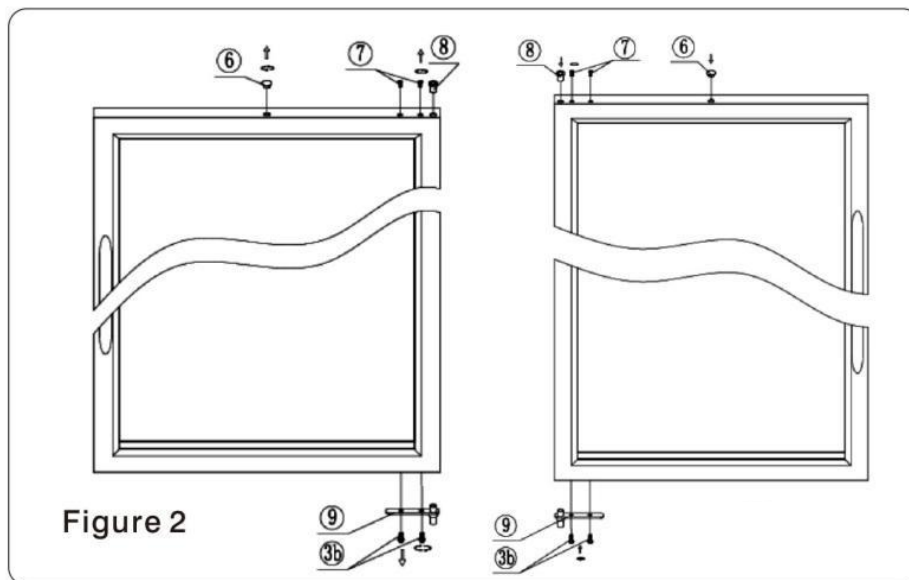
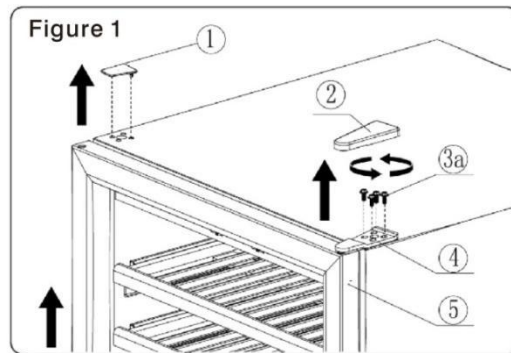

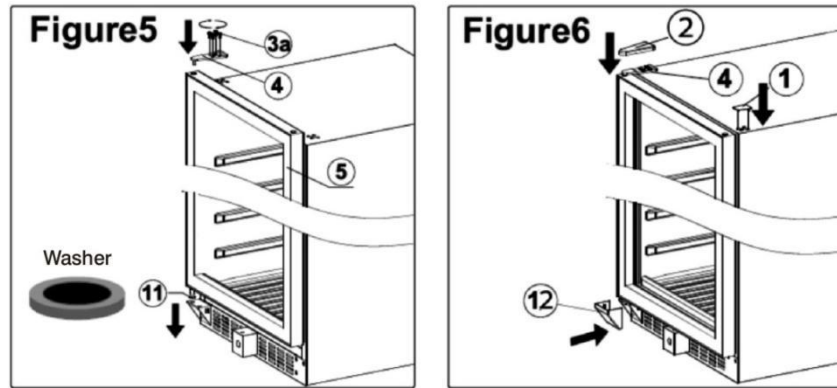

1. Pry up the hinge cover (1) and hinge cap (2) using a flat head screwdriver. Using a Phillips head screwdriver, loosen the hinge screws (3a) and remove the top hinge (4). You can now lift the door (5) off the bottom hinge and set it off to one side. Be careful not to lose the washer (11) between the bottom hinge and the door. You will need this later. Also remove lock hole cap (6) and screws (7) and (8) from the top of the door. The lock cap can be pried up using a small flat head screwdriver.
2. Using a Phillips head screwdriver, loosen screws (3b) to remove the hinge support rod (9) at the bottom of the door. Rotate the door 180° so that the top is now the bottom and vice versa. Attach the bottom hinge support rod (9) to the bottom corner of the door and attach with screws (3b).
3. Using a flat head screwdriver, pry off the bottom hinge cover (12). Using a Phillips head screwdriver, loosen and remove screws (3c) and (13) and bottom hinge (10).
4. Move bottom hinge (10) to the opposite side and re-insert all screws (3c) and (8). Bottom hinge cover (12) should clip back onto the bottom hinge (10).
5. Place the washer (11) over the hinge support rod (9) and place the door back on the bottom hinge by aligning the hinge support rod (9) with the outer hinge hole on bottom hinge (10).
6. Re-attach top hinge (4) using screws (3a). Insert lock cap (6), screws (7) and (8), and clip on hinge cap (2).

Stainless steel doors include a handle centered in the middle of the door. There is no need to alter the location of the handle.

Glass doors include integrated door pull handles. There is no need to alter the location of door pull handles.

Best way to store bottles

Your cabinet was designed to store a maximum number of bottles. We recommend that you observe the tips below to optimize loading.

- Disperse the bottles evenly to avoid concentrating weight in one place. Bottles must not touch either the back of the cabinet or the step at the bottom.
- Make sure that the bottles are not all grouped together either at the top or bottom of the

cabinet.

- Only pull out one shelf at a time. Never attempt to pull more than one.

How to maintain your wine cabinet

While your new wine cabinet is mostly maintenance free, we recommend the following to keep it looking clean and working properly.

- Turn off the power, unplug the appliance, and remove all items including all shelves.
- Wash the inside surfaces with a solution of warm water and baking soda (approximately 2 tablespoons of baking soda for each quart of water.)
- Wash the shelves with a mild detergent solution.
- Wring excess water out of the sponge or cloth when cleaning area of the controls, or any electrical parts.
- Wash the exterior with warm water and mild liquid detergent. Rinse well and wipe dry with a clean soft cloth.
- Vacuum the front grill and back of the unit twice yearly. Make sure the power is off before cleaning.
- It is recommended to clean the unit completely inside and out once a year to maximize the longevity of the wine cellar.

Power Loss

- Power failures that are corrected within a few hours should not affect the temperature of your appliance if you minimize the number of times the door is opened. If the power is going to be off for a longer period of time, you need to take other measures to protect your contents.
- If the unit is unplugged, loses power, or is turned off, you must **wait 3 to 5 minutes before restarting**. Attempting to restart the wine cellar before this time has elapsed may prevent the wine cellar from starting.

Moving Your Wine Cellar

- Remove all items.
- Securely tape down all loose items (shelves) inside your appliance.
- Turn the adjustable leg up to the base to avoid damage.
- Tape the door shut.
- Be sure the appliance stays secure in the upright position during transportation. If your wine cabinet is moved on an incline greater than 20 degrees, you may upset the balance in your compressor and cause damage. Do not do this. Also protect the outside of the appliance with a blanket or similar item.

What to do if something goes wrong?

Many common issues with your wine cellar can be solved very easily. Try the troubleshooting tips below should you experience any problems.

PROBLEM

POSSIBLE CAUSE

Wine cellar does not operate.

Not plugged in.

The appliance is turned off.

The circuit breaker tripped or a fuse has blown out.

Wine cellar is not cold enough.

Check the temperature control setting.

External environment may require a higher setting. (e.g. room needs to be air conditioned)

The door is opened too often.

The door is not closed completely.

The door gasket is not sealing properly.

Wine cellar is turning on and off frequently.

The room temperature is hotter than normal.

The door is opened too often.

The door is not closed completely.

The temperature control is not set correctly.

The door gasket does not seal properly.

The light does not work.

Not plugged in.

The circuit breaker tripped or a fuse has blown.

The light bulb has burned out.

The light button is "OFF".

Vibrations.

Check to assure that the wine cellar is on a level surface.

The wine cellar seems to make too much noise.

Contraction and expansion of the inside walls may cause popping and crackling noises.

The wine cellar is not on a level surface.

The door will not close properly.

The wine cellar is not on a level surface.

The door was reversed and not properly installed.

The gasket is dirty.

The shelves are out of position.

The area around the door, top, or side is hot.

Your wine cellar comes with a heating element near the door that keeps frost and condensation off the glass and it's normal for this area to feel warm. It will not affect the temperature inside the wine cellar.

SMITH & HANKS WARRANTY INFORMATION

WITH PROOF OF SALE, the following warranty coverage applies when this appliance is correctly installed, operated and maintained according to all supplied instructions.

FOR ONE YEAR from the date of sale this appliance is warranted against defects in material or workmanship. A defective appliance will receive free repair or replacement at option of Smith & Hanks. This warranty coverage is void outside the United States and if the appliance is ever used for other than private household purposes.

FOR THREE YEARS from the date of sale, the sealed refrigerant system (tubing, evaporator, condenser, and/or compressor) of this appliance is warranted against defects in material or workmanship. If a sealed system part is defective within the first year, a new part will be supplied and installed at no charge. If a sealed system part is defective after the first year, a new part will be supplied but not installed at no charge. You are responsible for the labor cost of part installation after the first year from the date of sale. This warranty coverage is void outside the United States and if the appliance is ever used for other than private household purposes.

This warranty covers ONLY product defects in material and workmanship, and will NOT pay for:

1. A service technician to clean or maintain the product.
2. A service technician to instruct the user in correct appliance installation, operation or maintenance.
3. Expendable items that can wear out from normal use within the warranty time period, including but not limited to filters, or light bulbs.
4. Service calls to correct improper appliance installation or to repair problems with house fuses, circuit breakers, house wiring, and plumbing or gas supply systems resulting from such installation.
5. Damage to or failure of this appliance resulting from improper installation, including installation that was not performed in accordance with electrical, gas or plumbing codes.
6. Damage to or failure of this appliance, including discoloration or surface rust, if it is not correctly operated and maintained according to all supplied instructions.
7. Damage to or failure of this appliance, including discoloration or surface rust, resulting from accident, alteration, abuse, misuse or use for other than its intended purpose.
8. Damage to or failure of this appliance, including discoloration or surface rust, caused by the use of detergents, cleaners, chemicals or utensils other than those recommended in all instructions supplied with the product.
9. Damage to or failure of this appliance resulting from natural or other catastrophe, such as flood, fire or storm.
10. Damage to or failure of parts or systems resulting from unauthorized modifications made to this appliance.
11. Service to an appliance if the model and serial plate is missing, altered or cannot easily be determined to have the appropriate certification logo.