

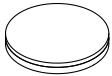









ASSEMBLY INSTRUCTIONS

Don't tighten any Bolts until all Bolts on a step have been started.

Thank you for purchasing this quality product. Be sure to check all packing material carefully for small parts, which may have come loose inside the carton during shipment. Identify and count all parts and compare with the HARDWARE LIST below.

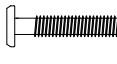
NO.	PARTS LIST		Q'TY
A		Wooden Seat	1 pre-assy
		Top Ring	
B		Swivel	1 pre-assy
		Middle Ring	
C		Bottom Ring	1
D		Legs	4
E		Seat Back	1

NO.	PARTS LIST		Q'TY
1		∅ 1/4" X 10 X 1 mm Spring Washer	16
2		∅ 1/4" X 16 X 1 mm Flat Washer	16
3		M6 X 15 mm JCBC	16
4		M6 X 25 mm JCBC	3
5		Allen Key 4 mm	1

STEP 1

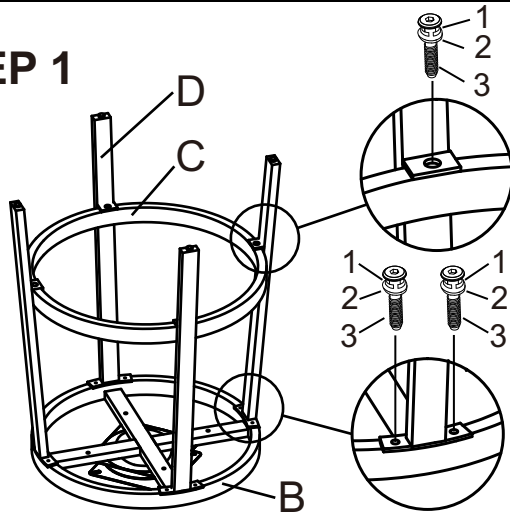

1. Attach the four Legs (D) to the Middle Ring w/ swivel (B), using JCBC (3), Spring Washer (1), Flat Washer (2) and Allen Key (5) to tighten, as shown
2. Attach the Bottom Ring (C) to the Legs, using JCBC (3), Spring Washer (1), Flat Washer (2) and Allen Key (5) to tighten, as shown.

STEP 2

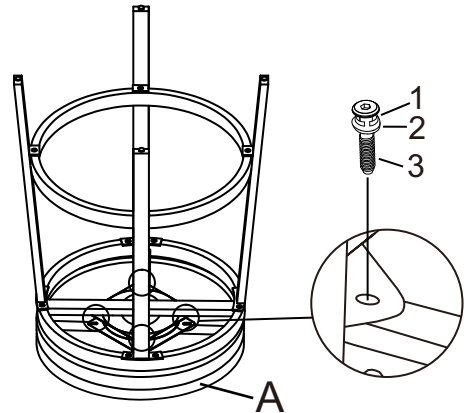

1. Upside down the Wooden seat w/top ring (A) and put in on a smooth and stable working stand.
2. Attach the assembled Legs frame to the Seat w/ top ring (A), using JCBC (3), Spring Washer (1), Flat Washer (2) and Allen Key (5) to tighten, as shown.

STEP 3

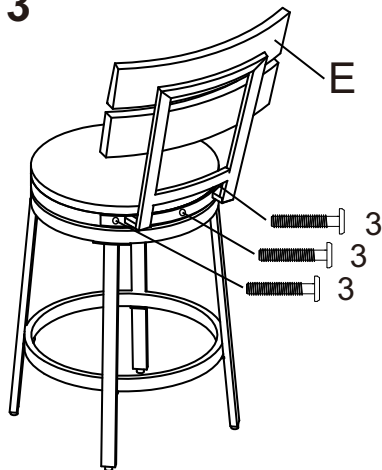

1. Right side up the Leg frame.
2. Attach the Seat Back (E) to the Wooden Seat w/ top ring (A), using JCBC (4) and Allen Key (5) to tighten, as shown.

STEP 4

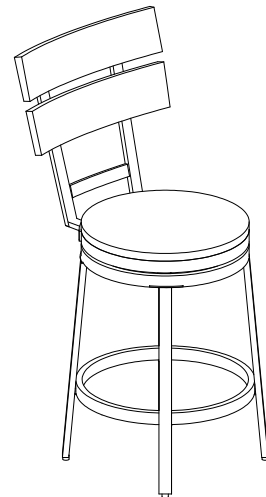

1. It's complete for use.

Caution: 1. All bolts must be tightened mandatorily in each step.
2. It is also mandatorily recommended to periodically check bolts and retighten as needed.