

## 1. Prepare Tap for Installation

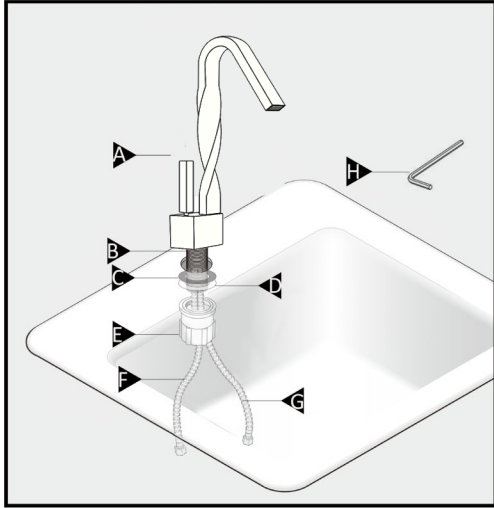

### 1. Parts List

- A: Tap Body
- B: Fixed Bolt
- C: Rubber Washer
- D: Metal Washer
- E: Mounting Nut
- F: Hot Water Hose
- G: Cold Water Hose
- H: Hexagon Wrench

### 2. Tools Required (Not Included)

1. Safety glasses
2. Phillips screwdriver
3. Adjustable Wrench
4. Cloth

### 3. Tips

1. Working water pressure at 0.4-0.8 MPA.
2. For protecting the service life, it is not allowed to touch or cut with sharp tool.

## 4. Caution — Tips for removal of old tap:

Always turn water supply OFF before removing existing tap or disassembling the valve. Open tap handle to relieve water pressure and ensure that complete water Shut-off has been accomplished.

### Icon Legend



Above sink

Blow sink

## 5. Remarks

- 1: Without affecting their performance, accessories may be changed without further notice.
- 2: Drawing for reference only, product size & shape refer to actual faucet.
- 3: Thanks for choosing our product.

## 2. Installation Instructions

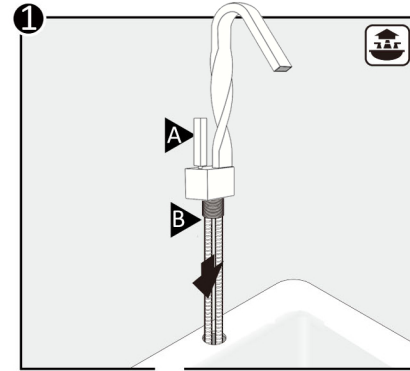

1. Take off the mounting nut (E).
2. Install tap Body (A) in hole on sink.

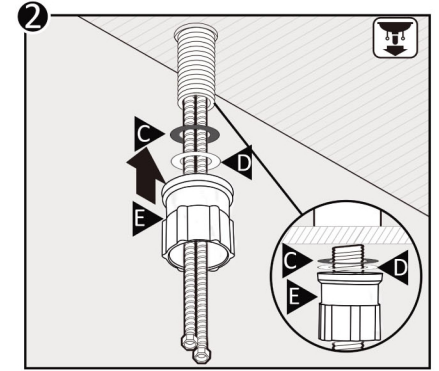

2. Mounting rubber washer (C) and metal washer (D) up onto tap body (A) under sink and secure with mounting nut (E).

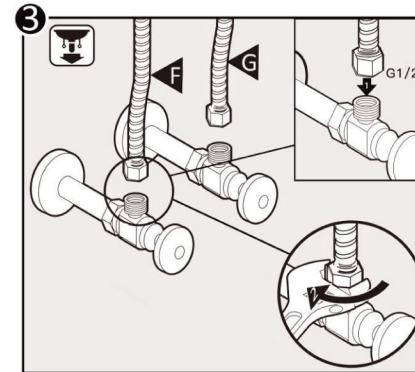

3. For pipe thread size is 1/2", directly attach flexible supply lines (F, G) to shut off valves. Tighten with a wrench.

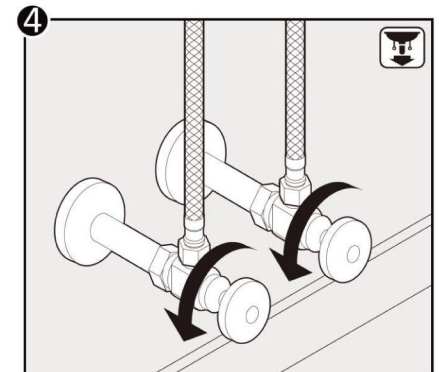

4. Attach the water supply lines in a conspicuous location. Turn on Hot (F) and Cold (G) water supply to check for leaks