

Assembly Instructions

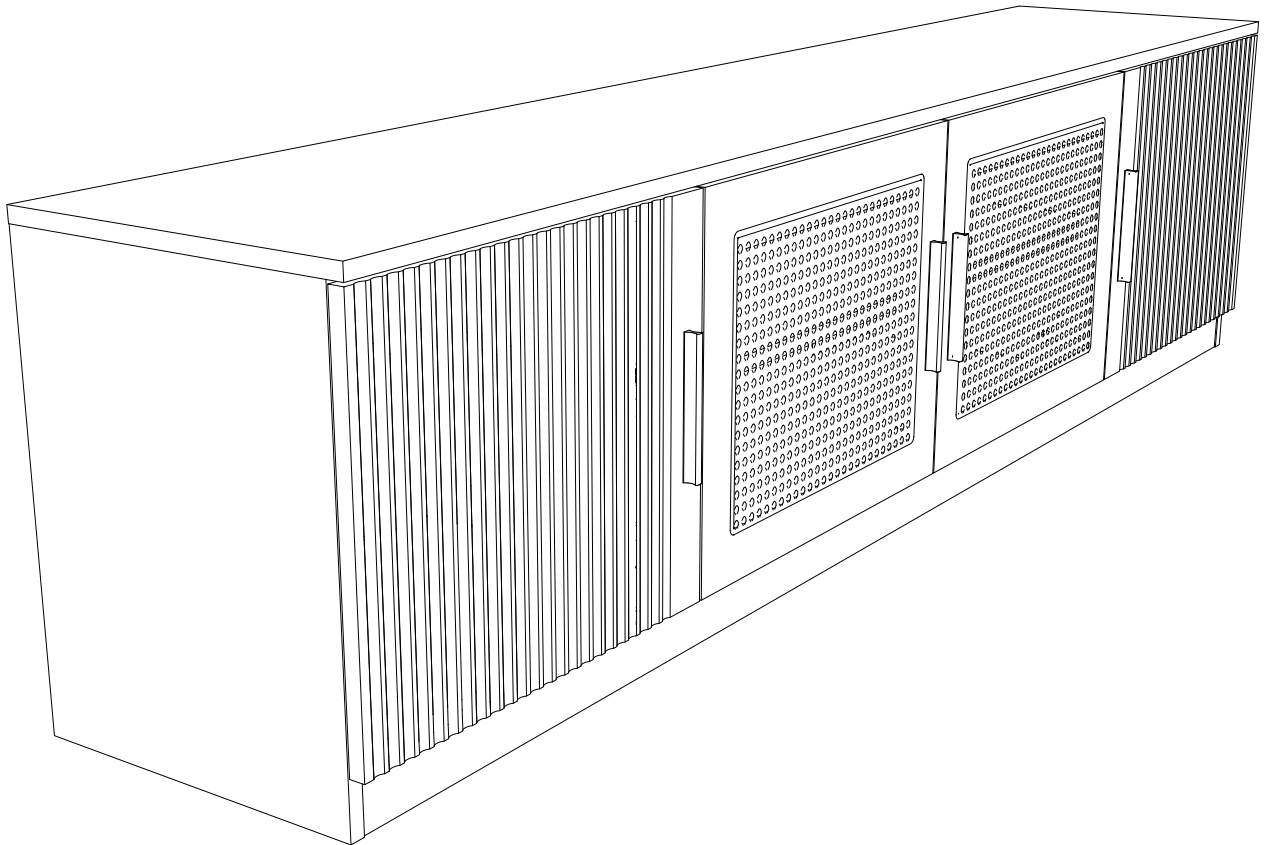

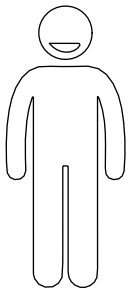

X2

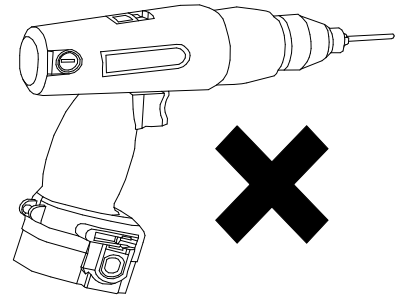
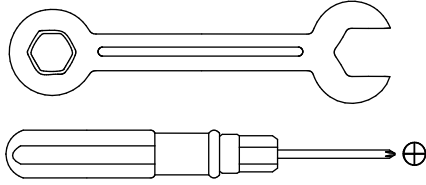

We recommend using hand tools for assembly.

If an electric screwdriver is used, reduce power and torque to avoid damage to the product.

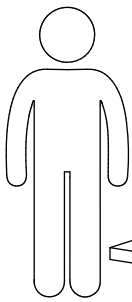

?

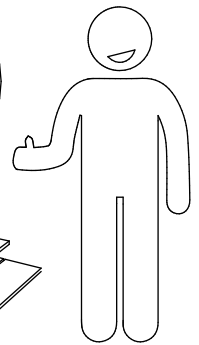
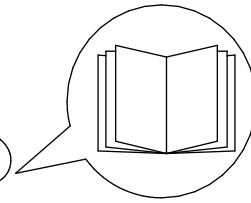
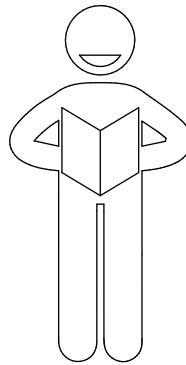
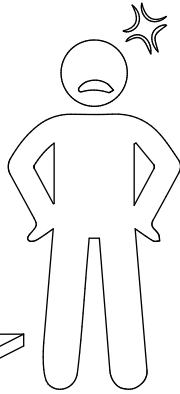

AVOID SCRATCHES

In order to avoid scratching this furniture should be assembled on a soft layer-could be a rug.

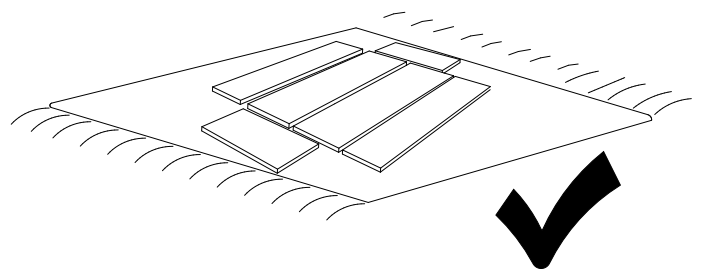
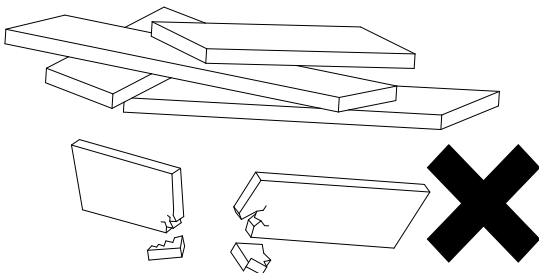

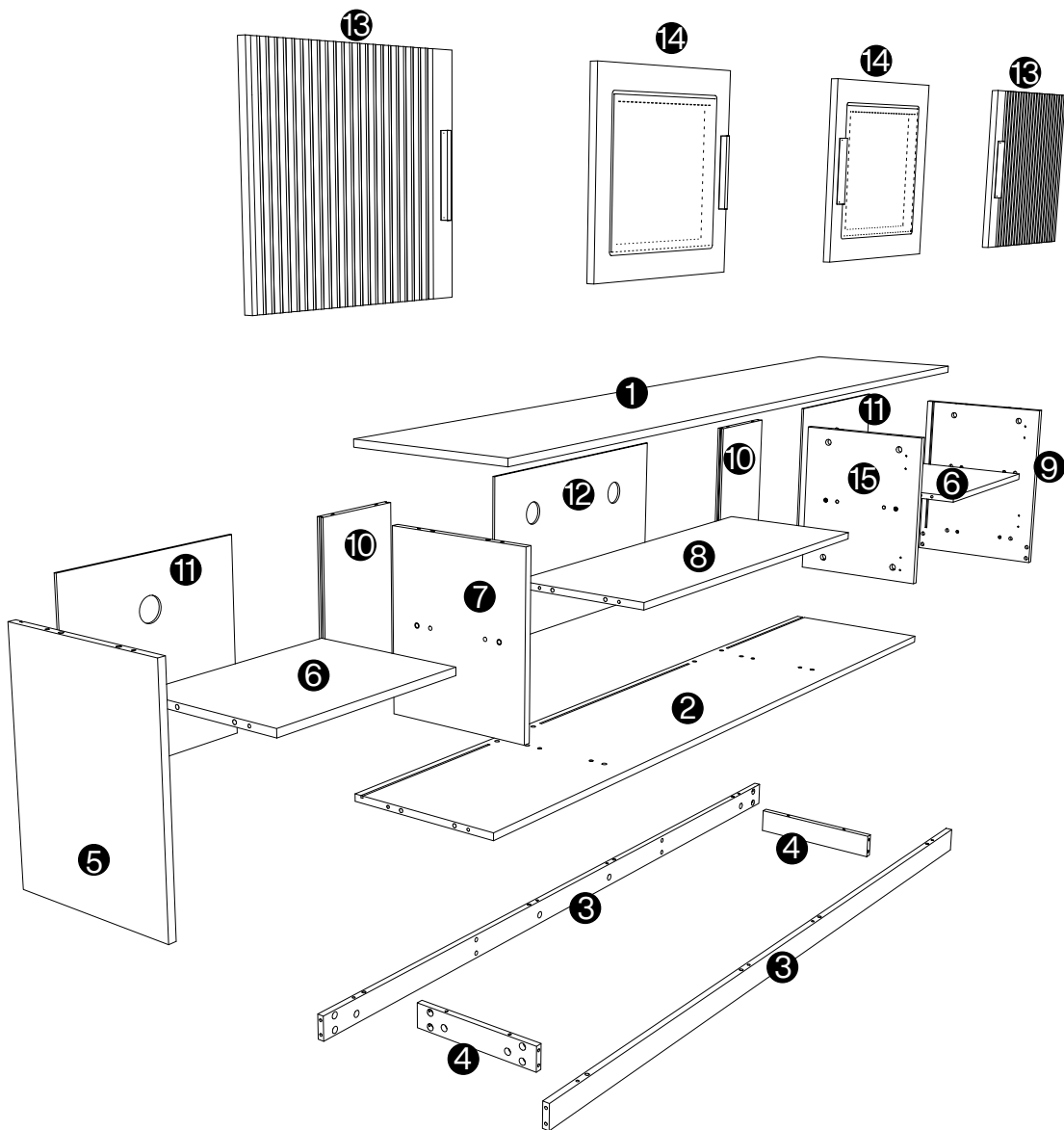



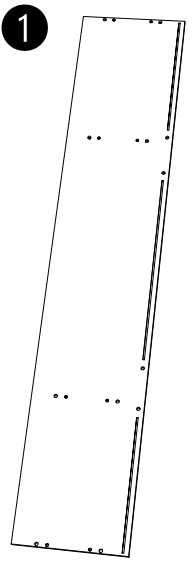
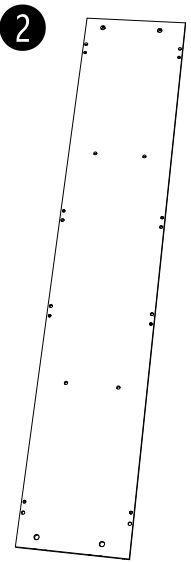
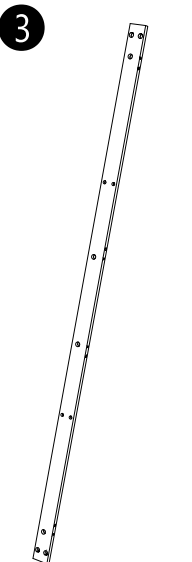
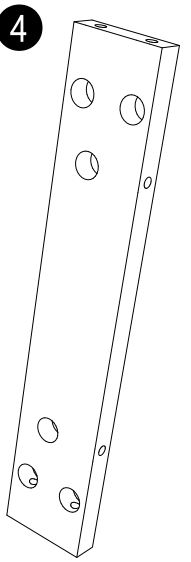
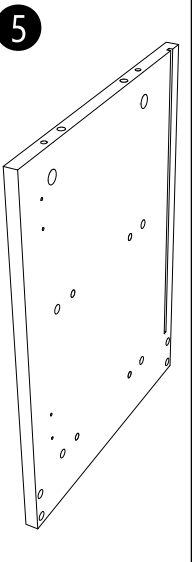
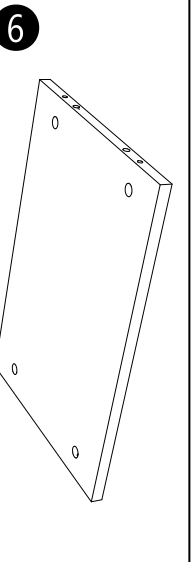
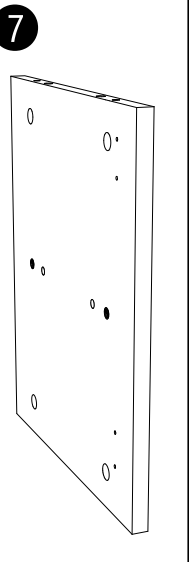
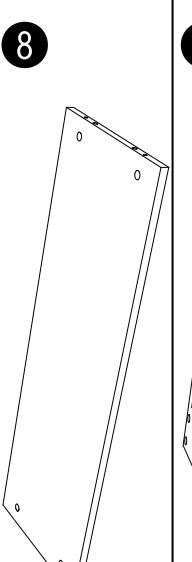
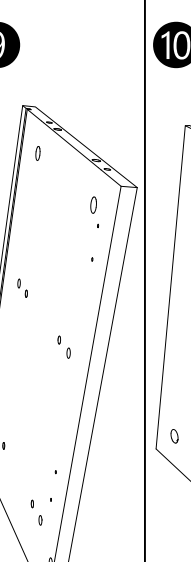
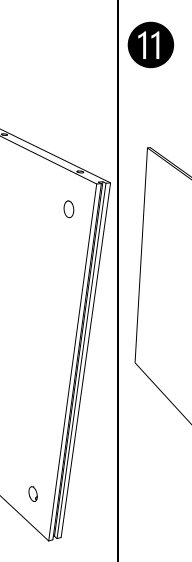
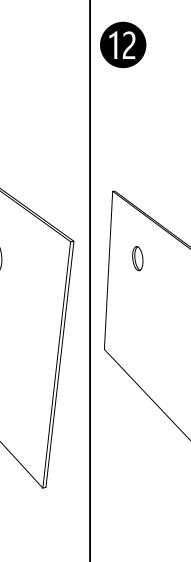
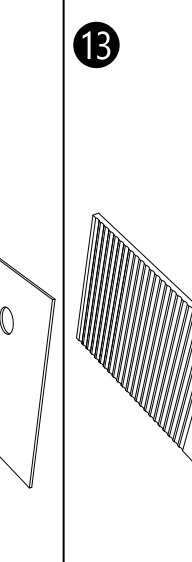
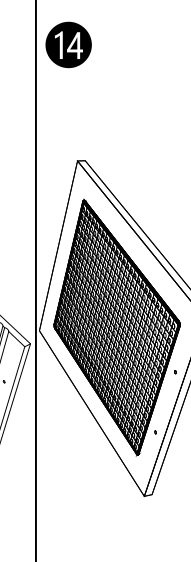
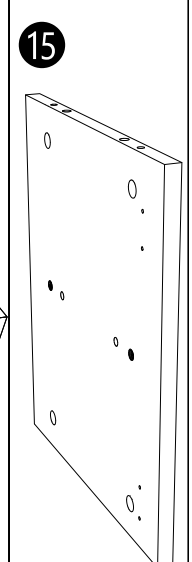

⚠ Caution

Make sure all parts are included. Most board parts are labeled or stamped on the raw edge. Contact us for a free replacement if you encounter any damaged or missing parts.

Parts List

 1 pc	 1 pc	 2 pcs	 2 pcs	 1 pc	 2 pcs	 2 pcs	
 1 pc	 1 pc	 2 pcs	 2 pcs	 1 pc	 2 pcs	 2 pcs	 1 pc

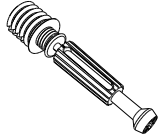
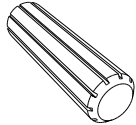
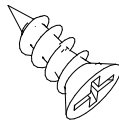
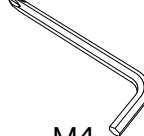
Hardware List

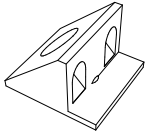
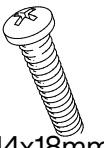
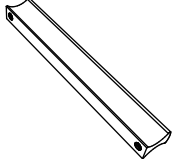
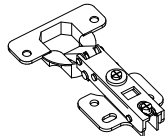
 Ø15x12mm 64 pcs	 M6x40mm 64 pcs	 Ø8x30mm 36 pcs	 Ø3.5x14mm 62 pcs	 M4 1 pc	 8 pcs	 14 pcs
 M4x18mm 8 pcs	 4 pcs	 8 pcs				

Installation of Cams and Pins

Read each step carefully before starting. Each step of instruction should be performed in the correct order. If these steps are not followed in sequence, assembly difficulties may occur.

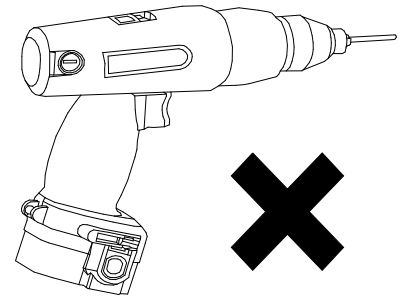

No gap

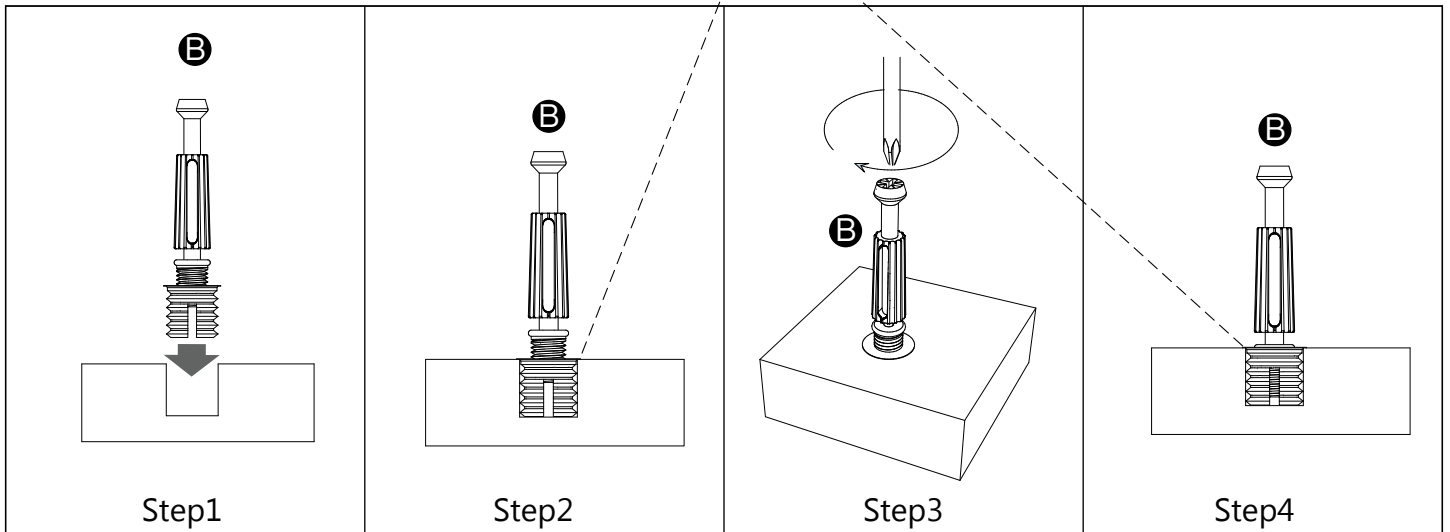

Screw the pin into the hole. Set the cams correctly by aligning the head of the cams with the lock pins. Lock the cam by turning the cam head with a screwdriver until it is tightened. Please do not use an electric screwdriver to assemble the unit.

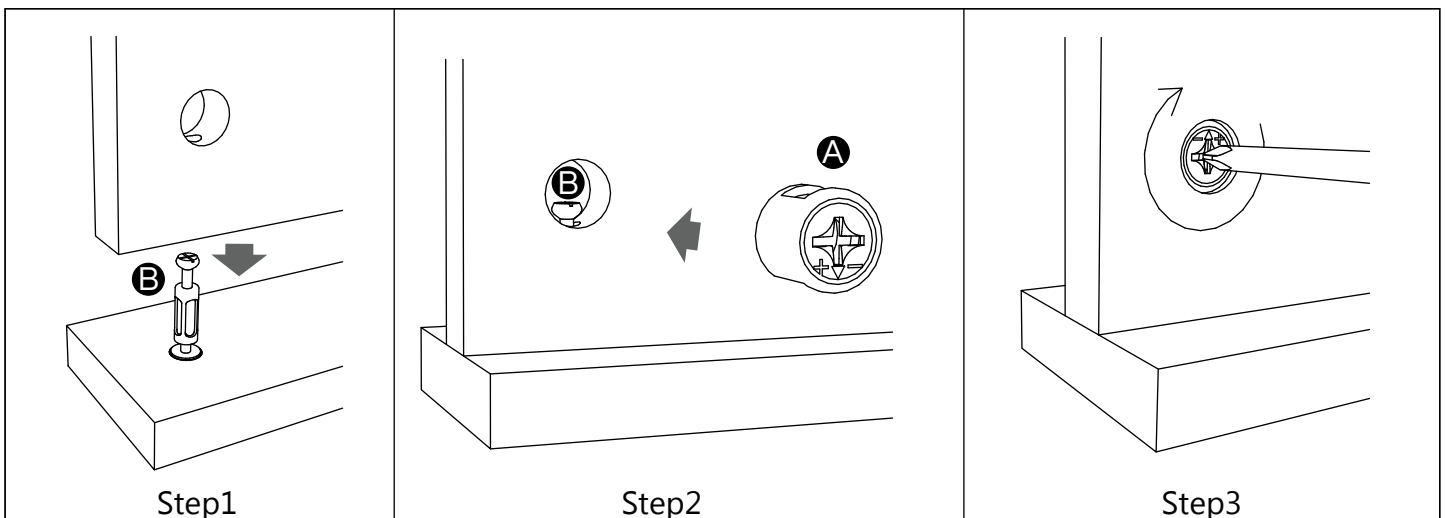

1

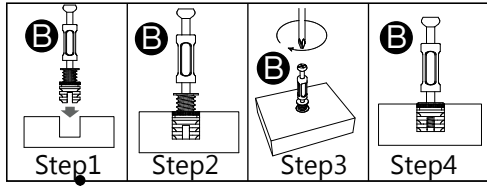

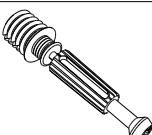
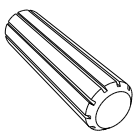
B

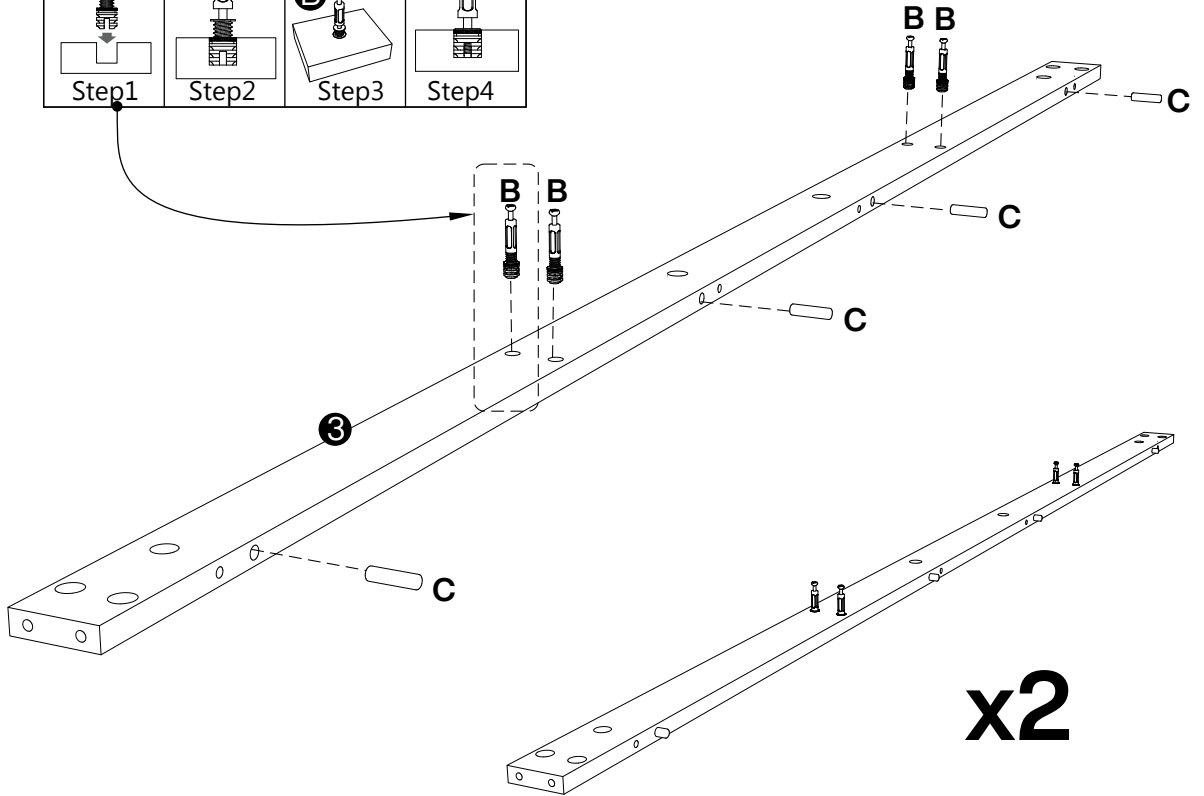
M6x40mm
8 pcs
C

Ø8x30mm
8 pcs

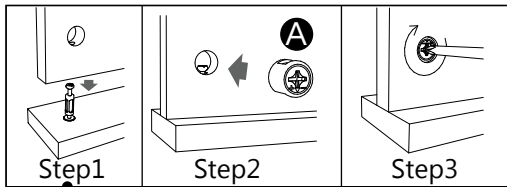

2



A

Ø15x12mm
8 pcs

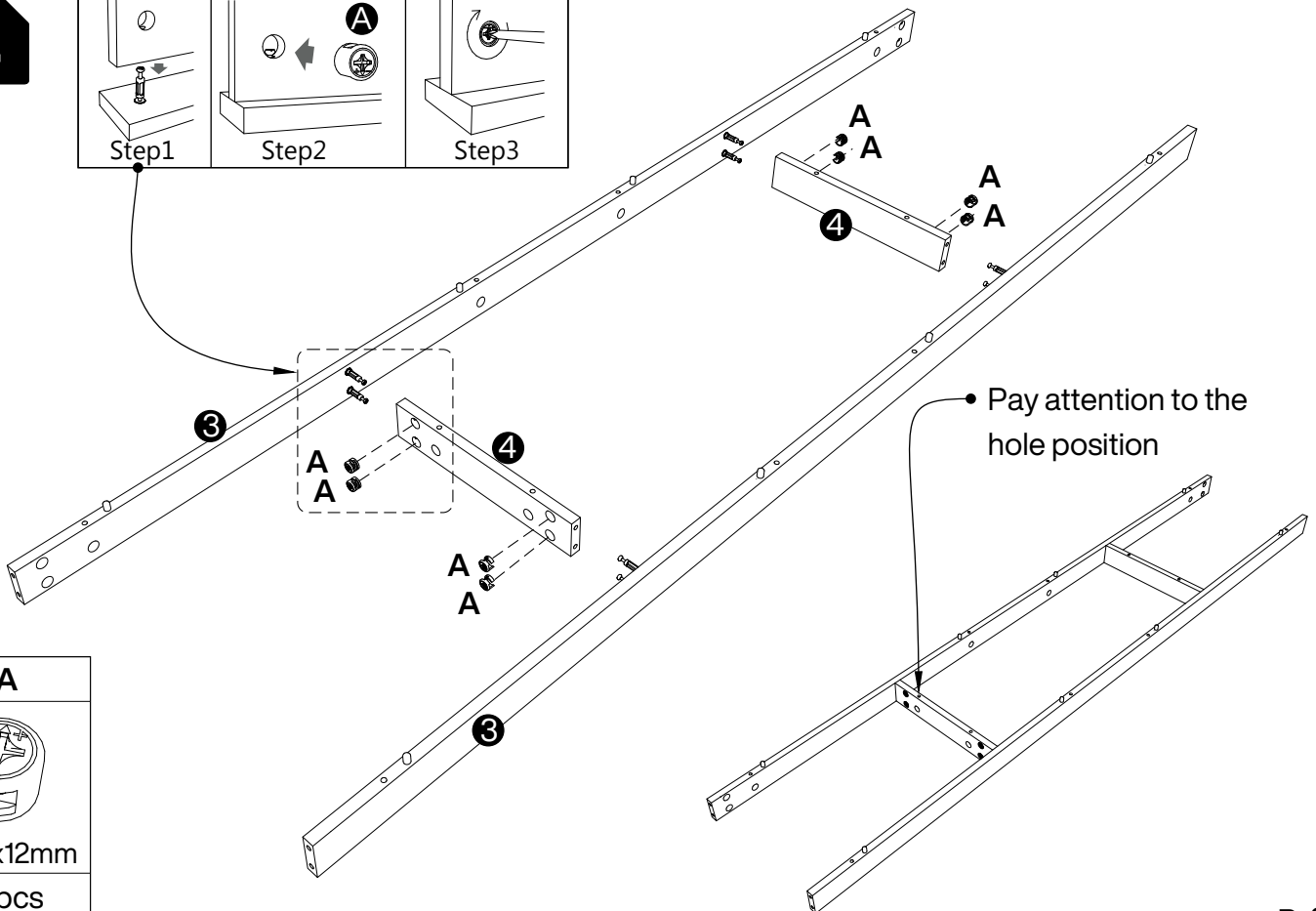

3

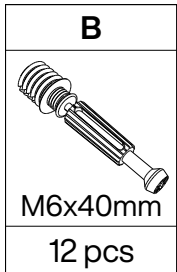
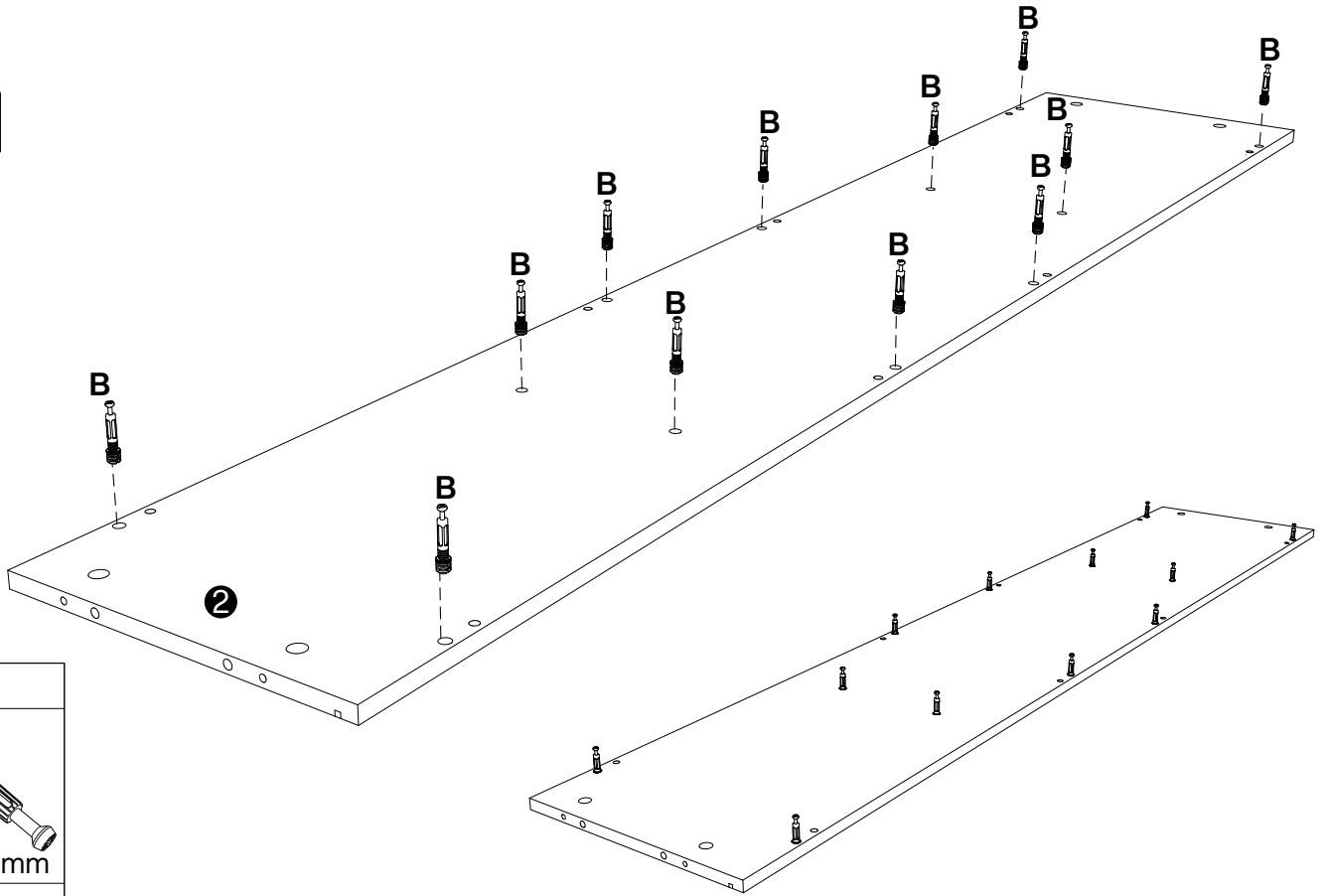

4

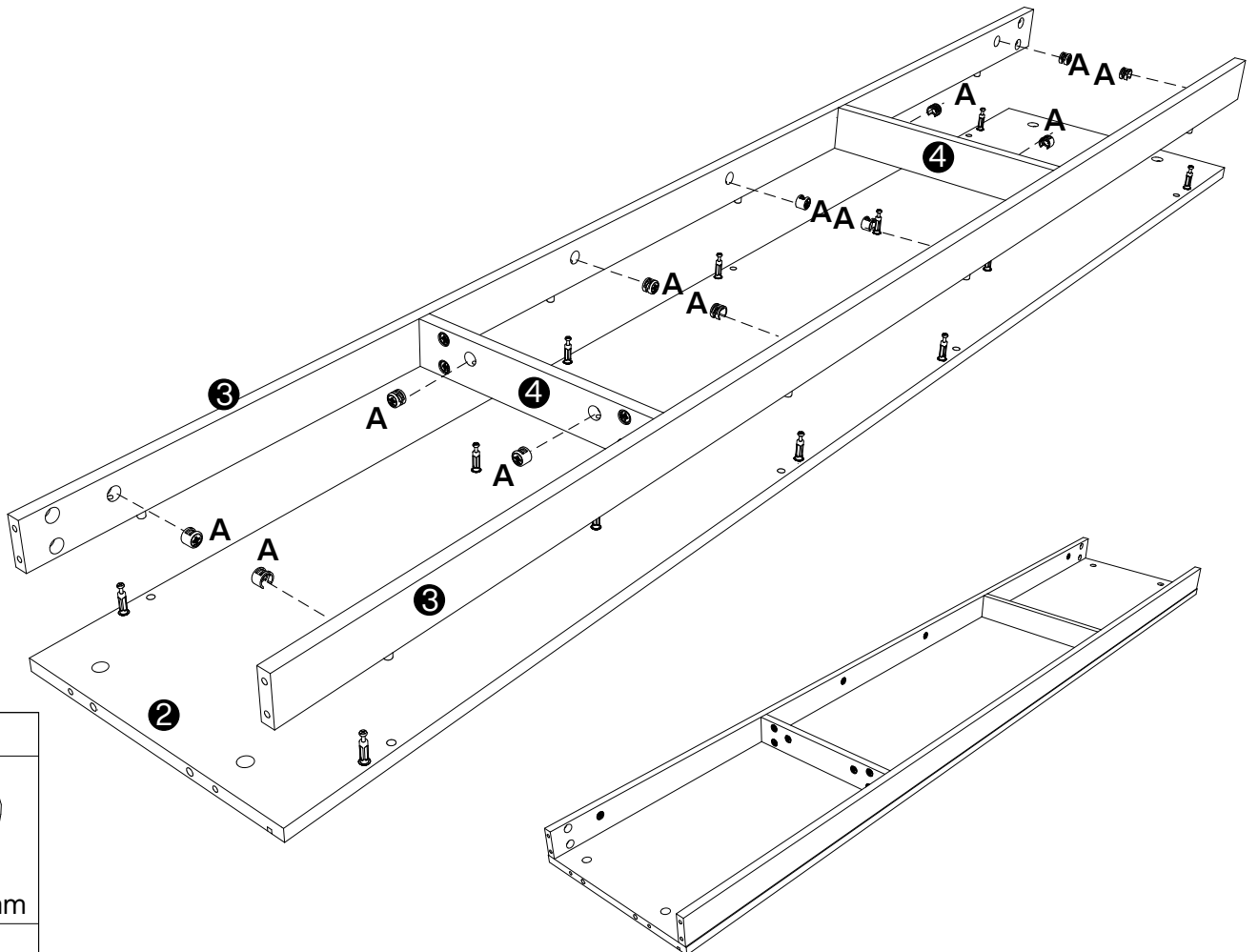

5

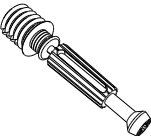
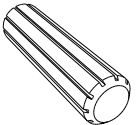
B

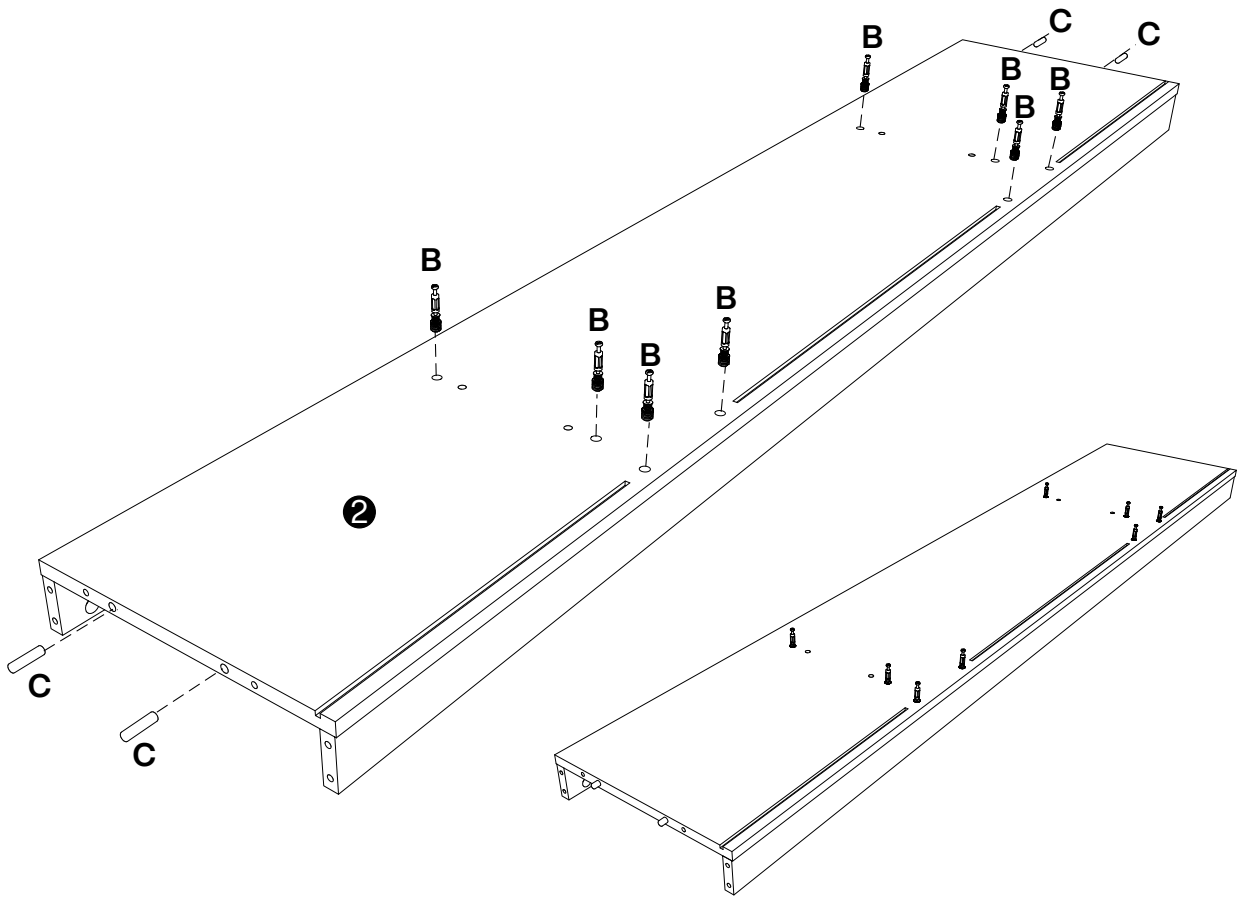
M6x40mm
8 pcs
C

Ø8x30mm
4 pcs

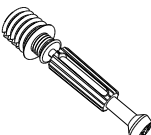
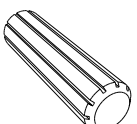

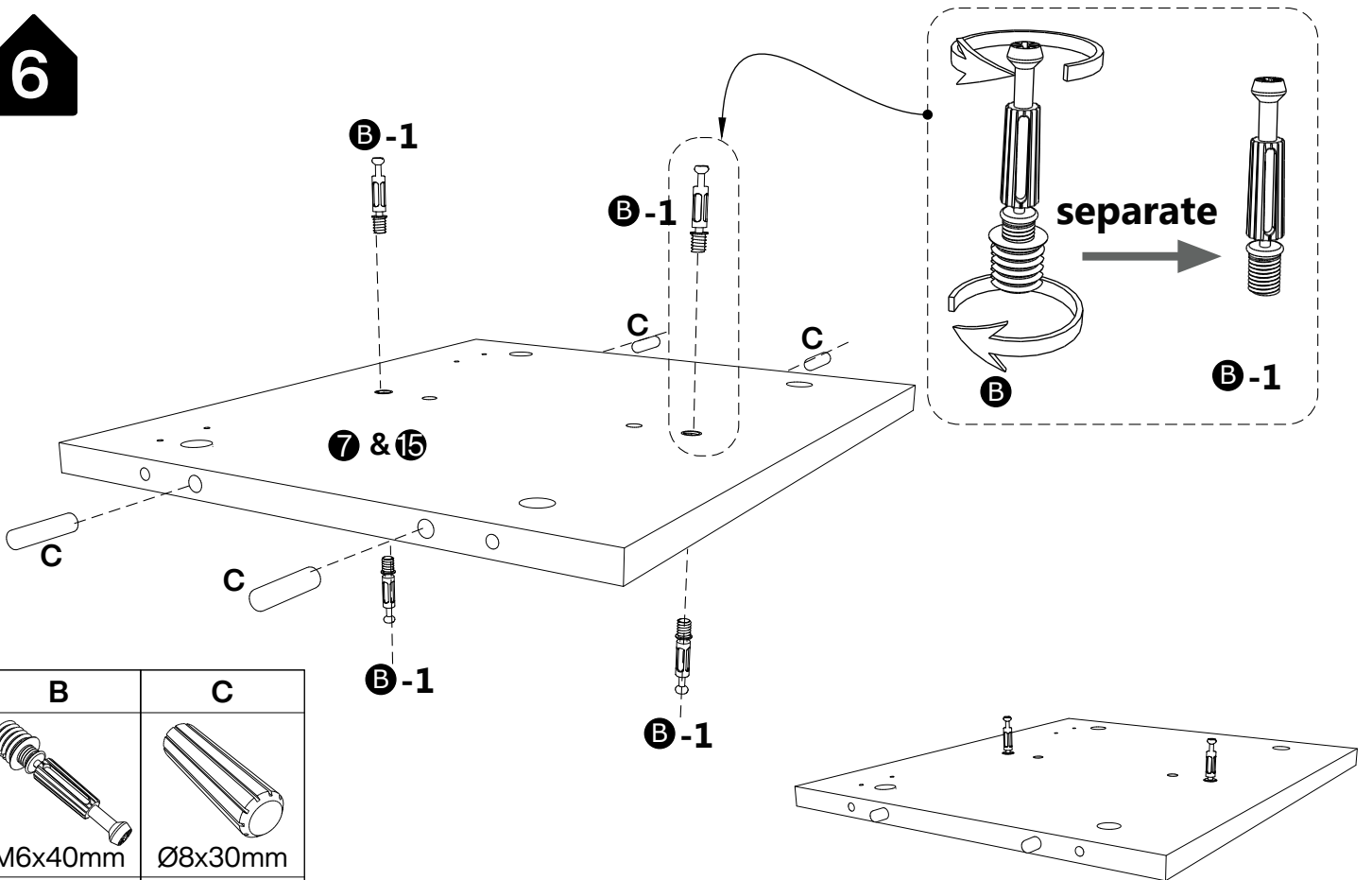

6

B	C
	
M6x40mm	Ø8x30mm
8 pcs	8 pcs

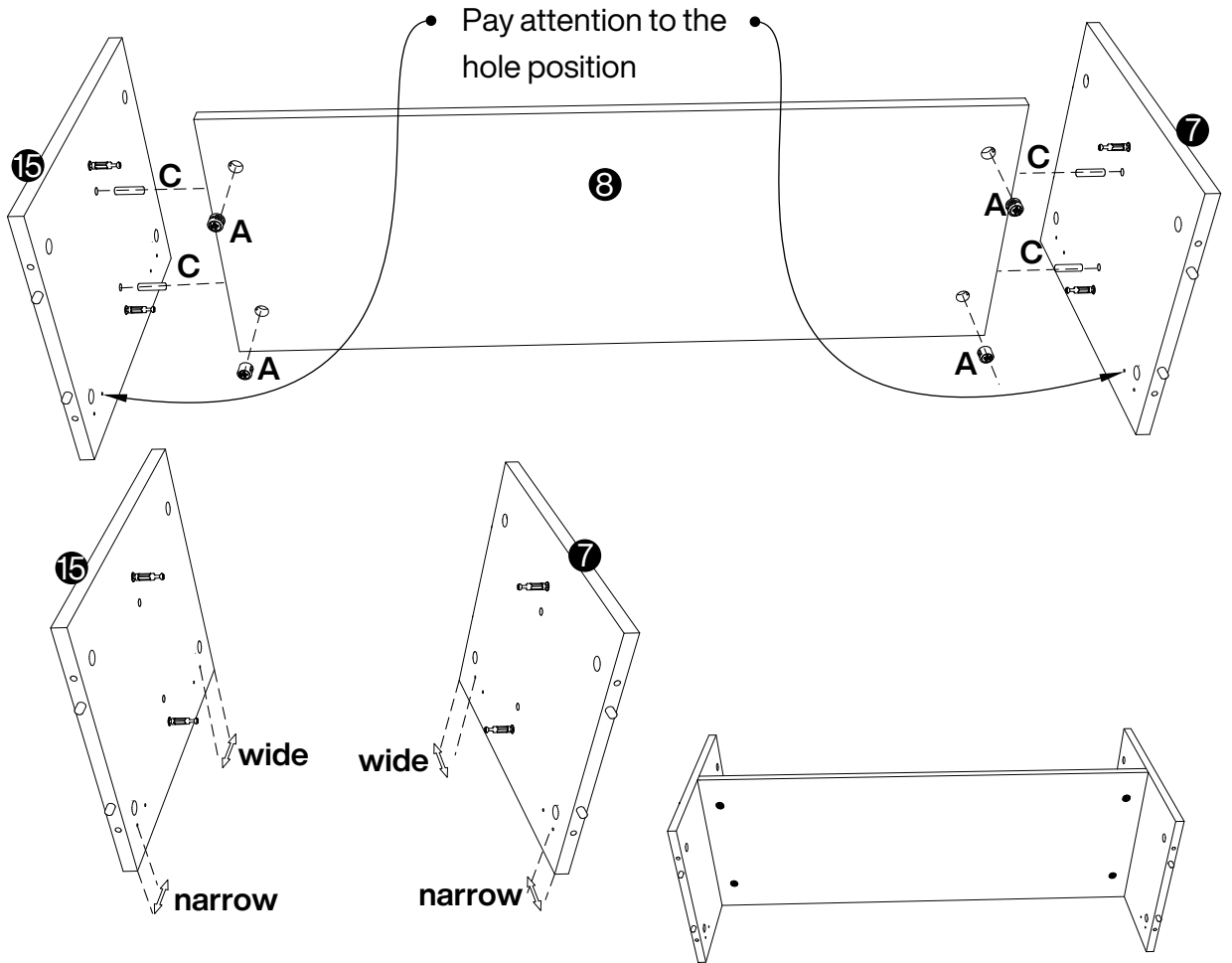

7

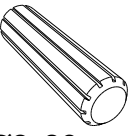

A

Ø15x12mm
4 pcs
C

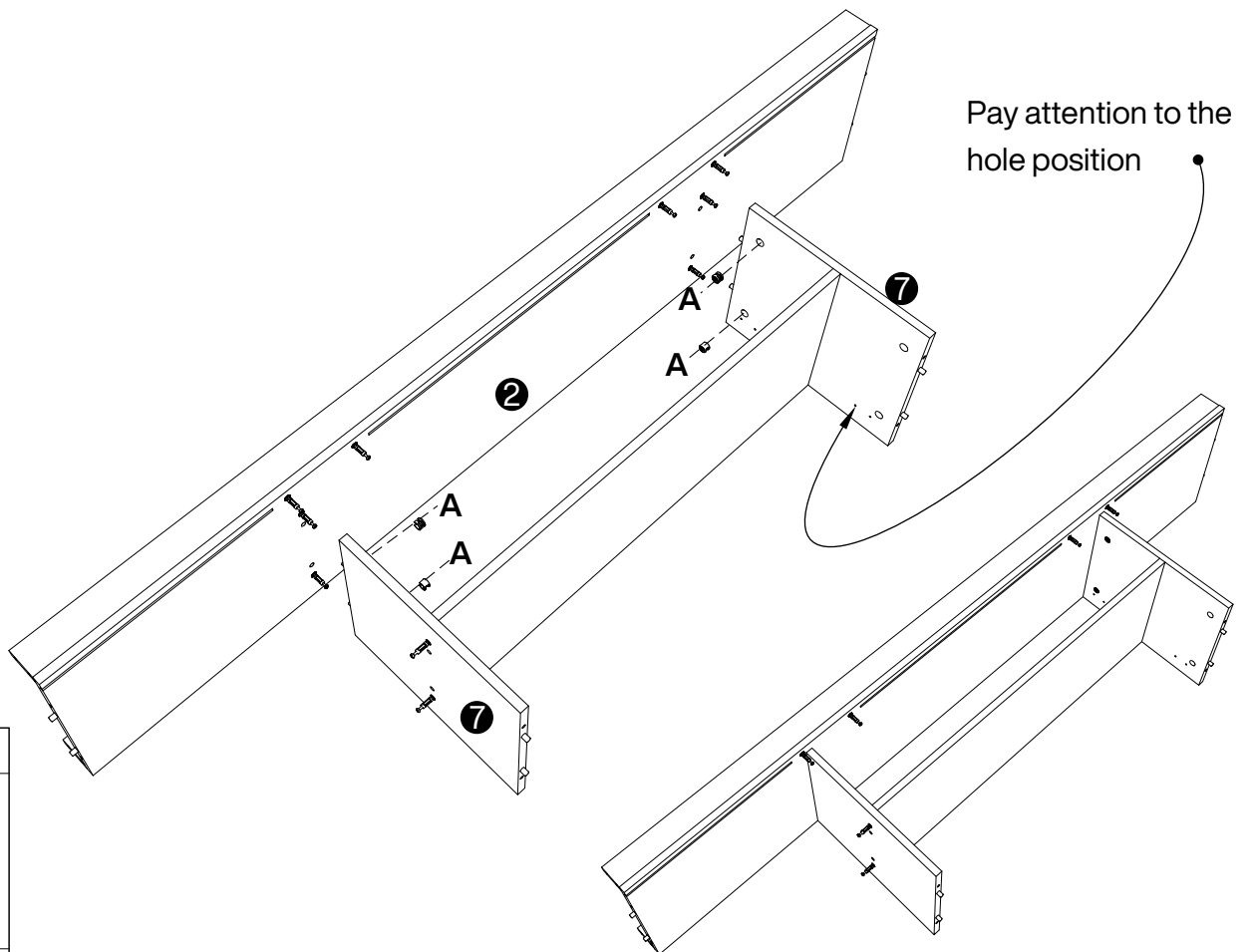
Ø8x30mm
4 pcs

8



A

Ø15x12mm
4 pcs

9

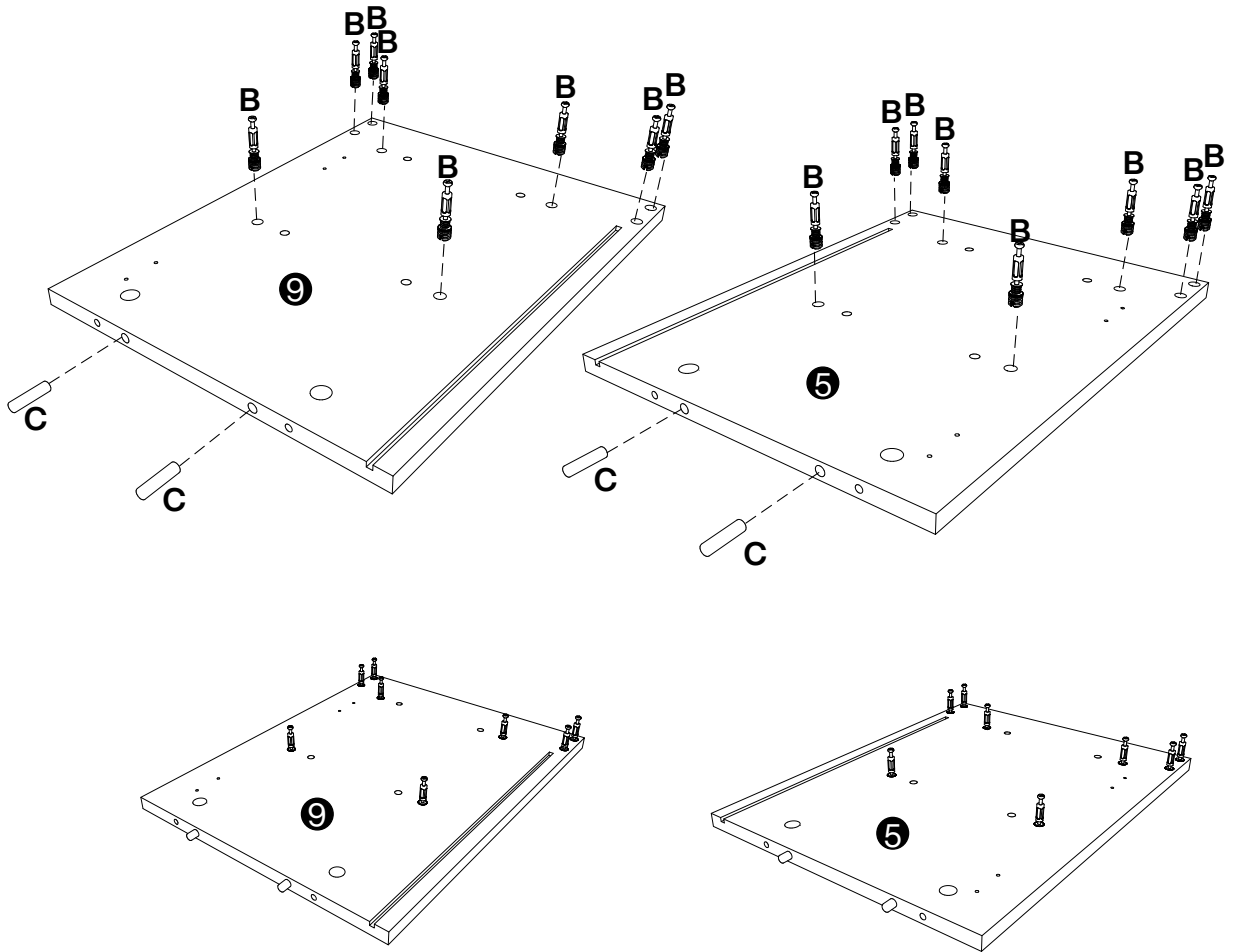

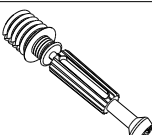
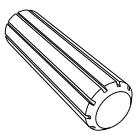
B

M6x40mm
16 pcs
C

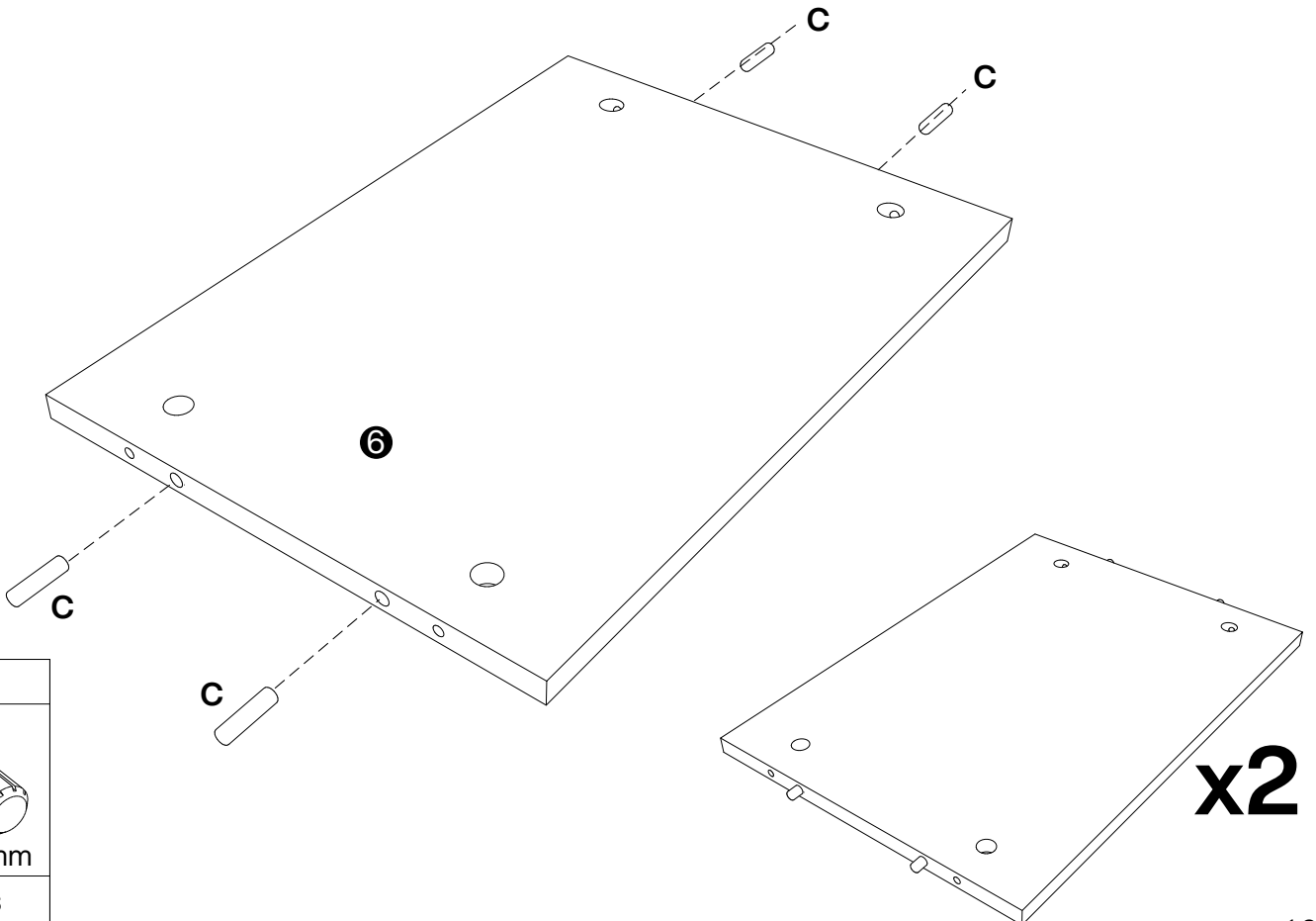
Ø8x30mm
4 pcs

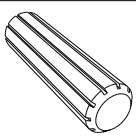
10

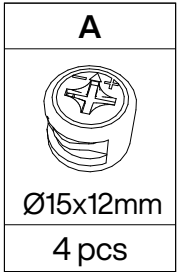
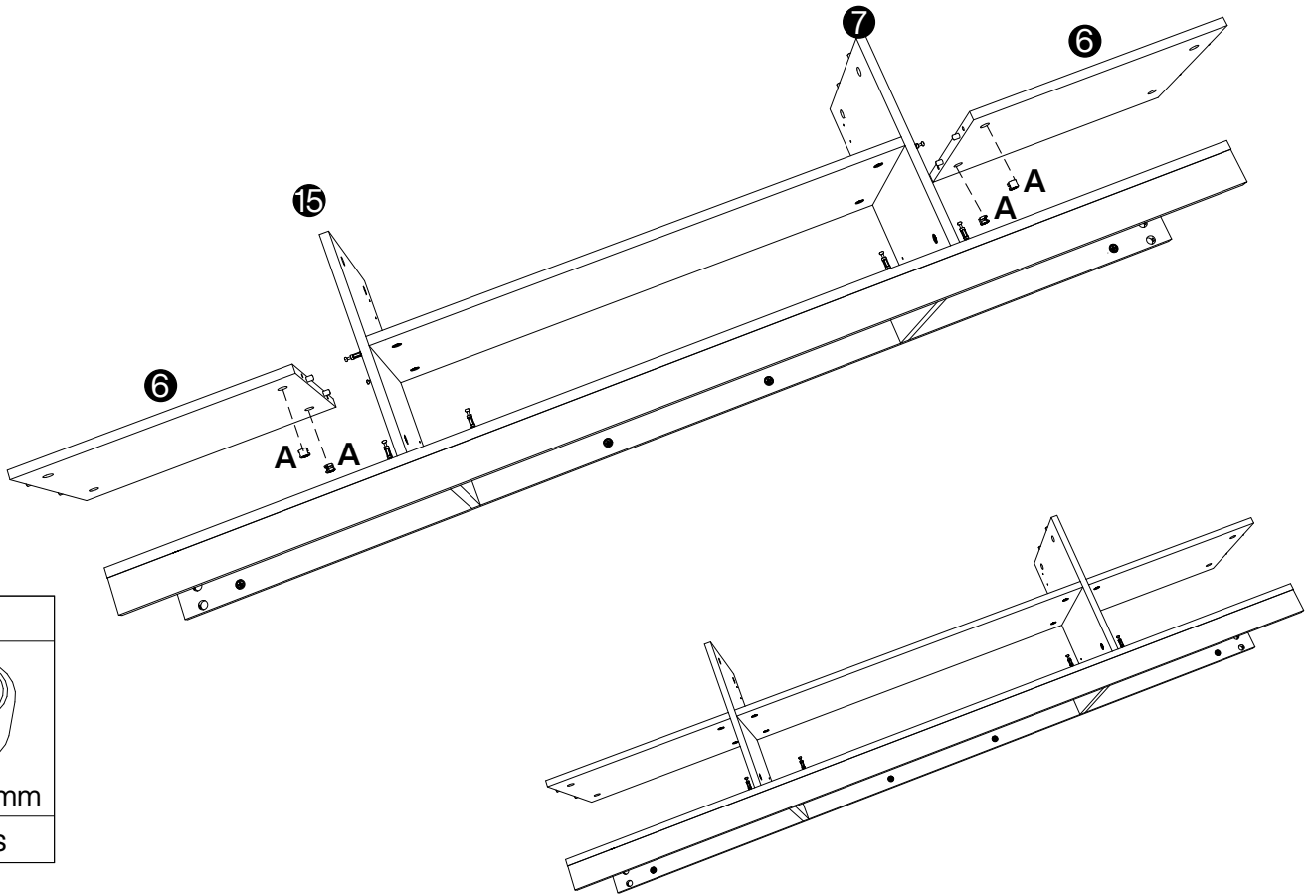

C

Ø8x30mm
8 pcs

11

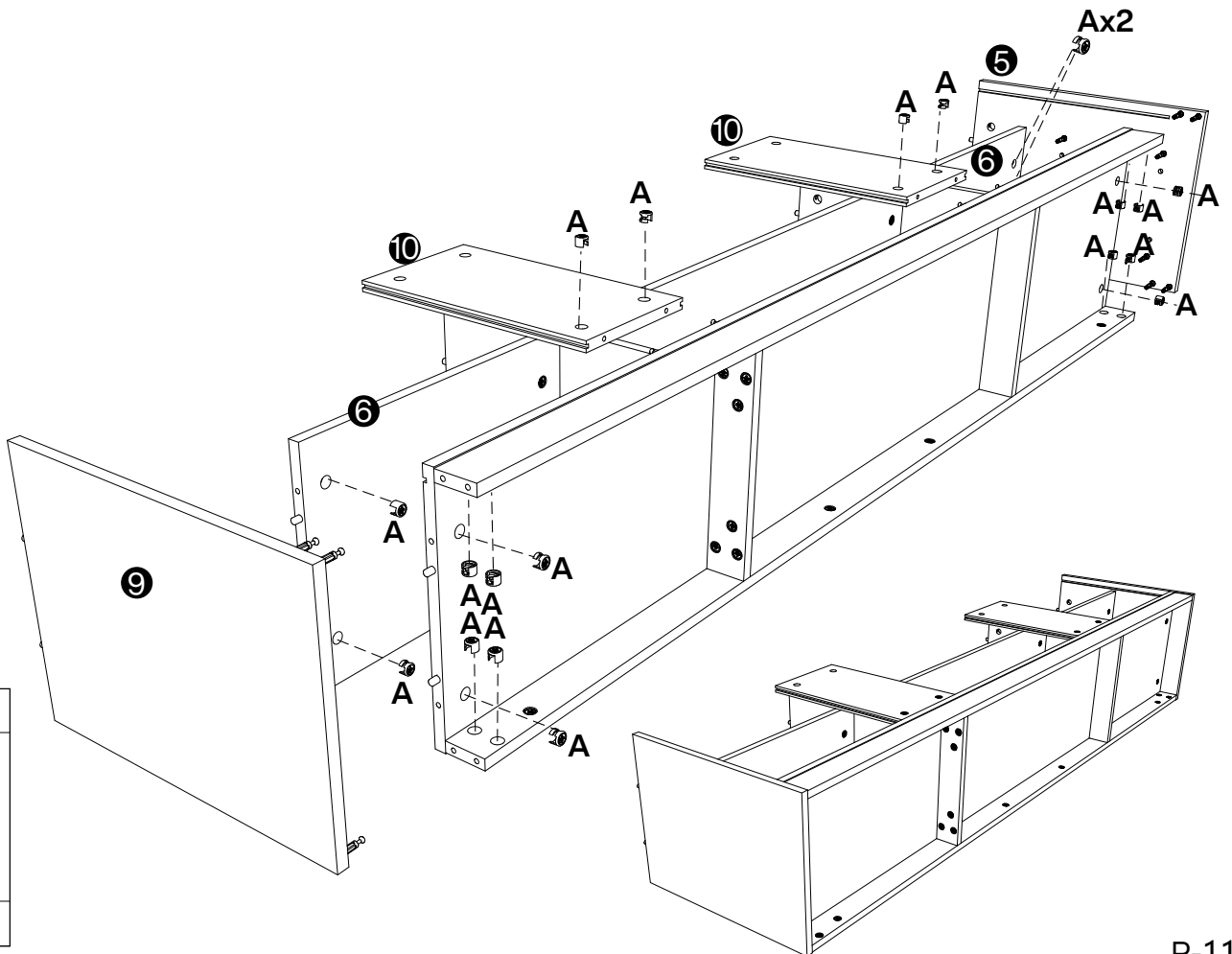

12



13

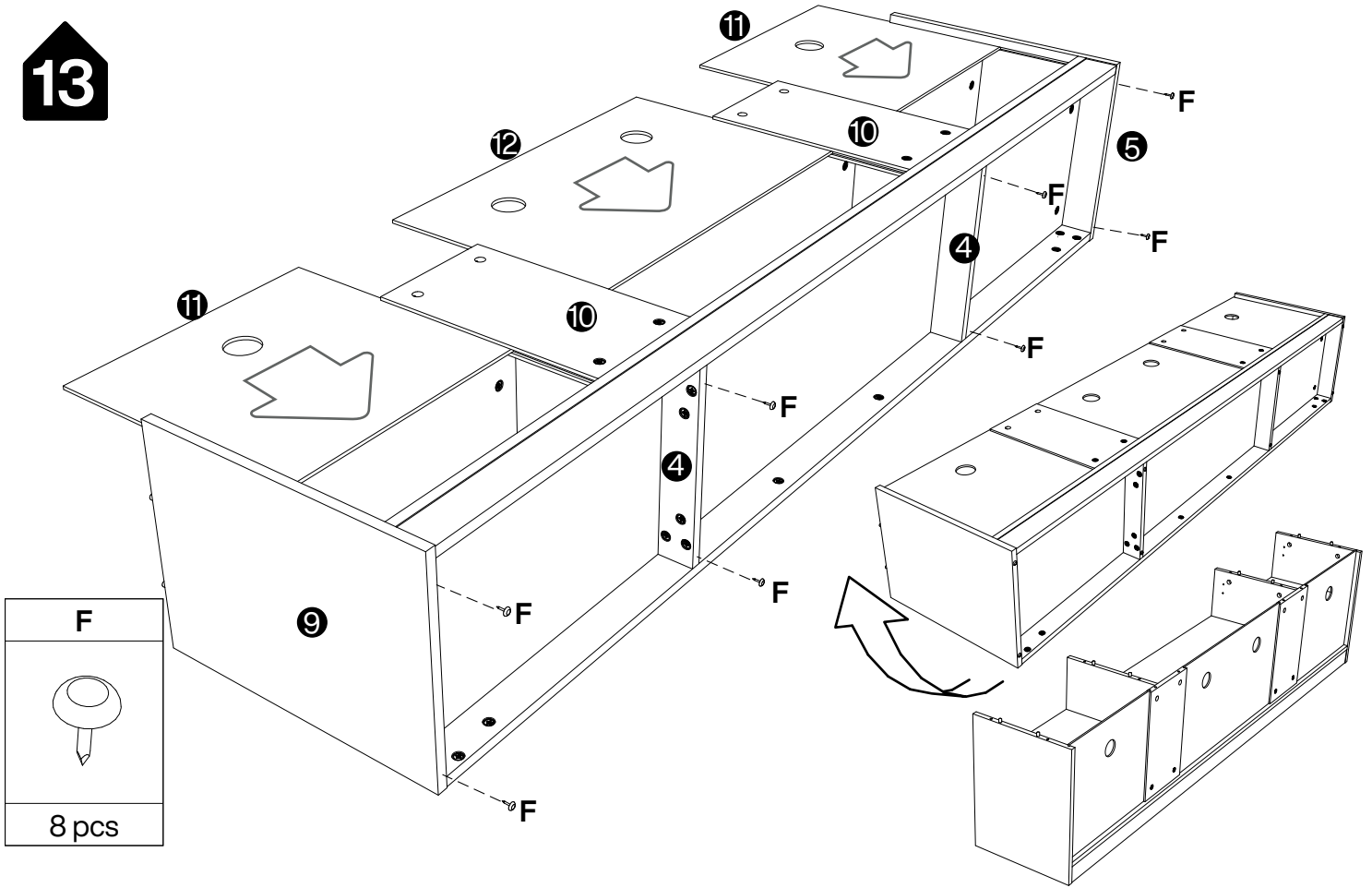

14

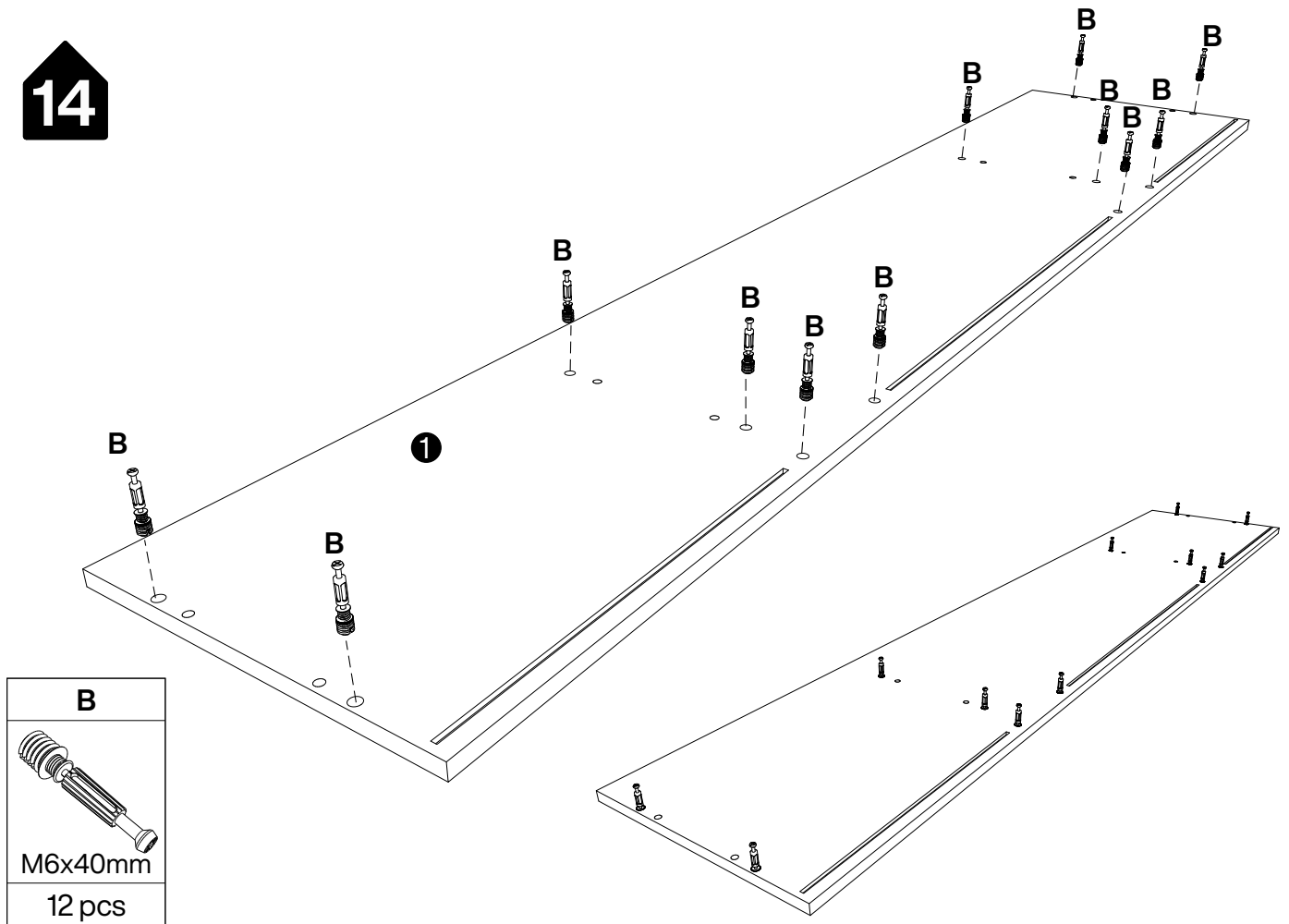

15

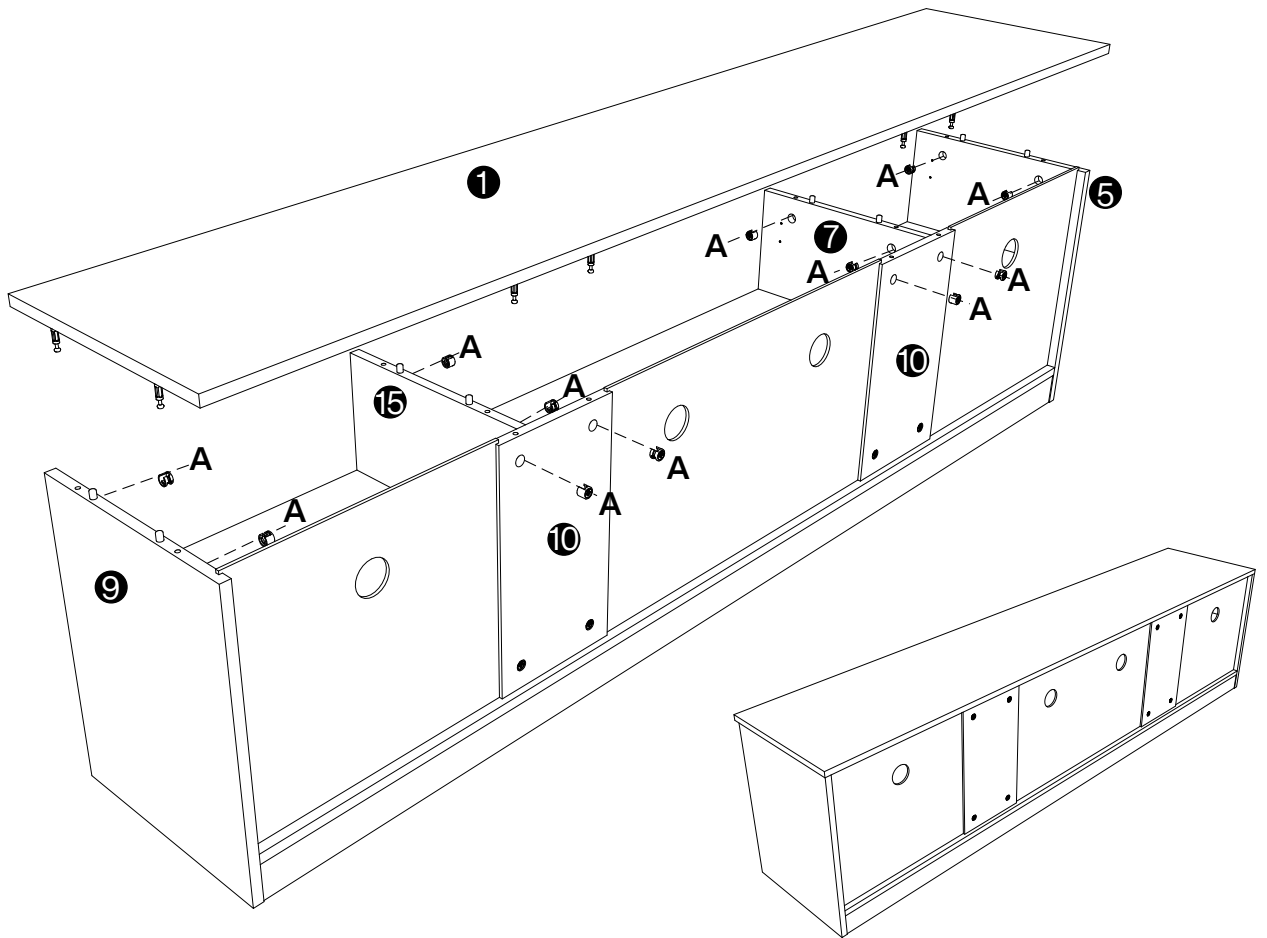

A
Ø15x12mm
12 pcs

16

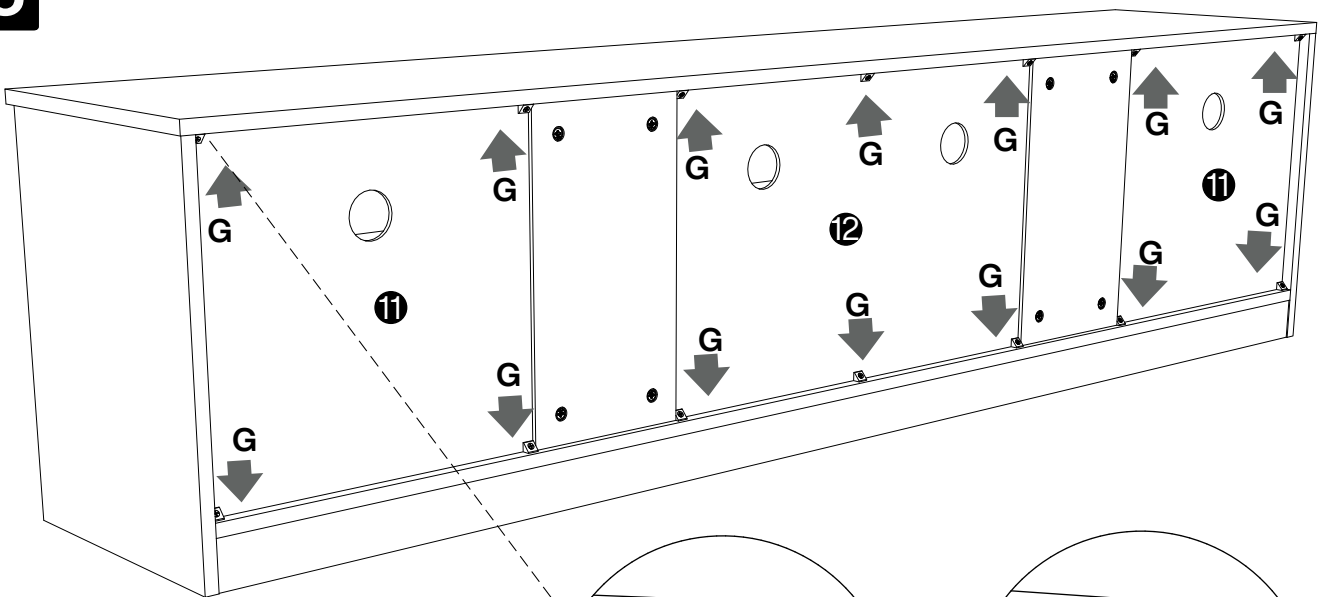

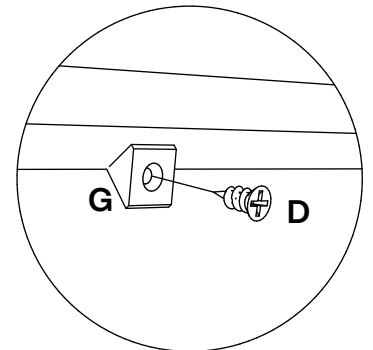
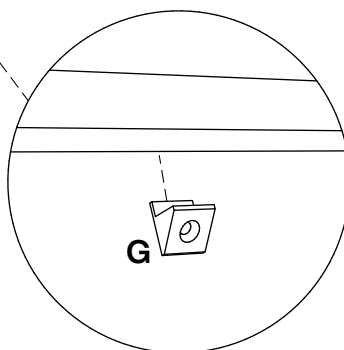

D	G
Ø3.5x14mm	
14 pcs	14 pcs

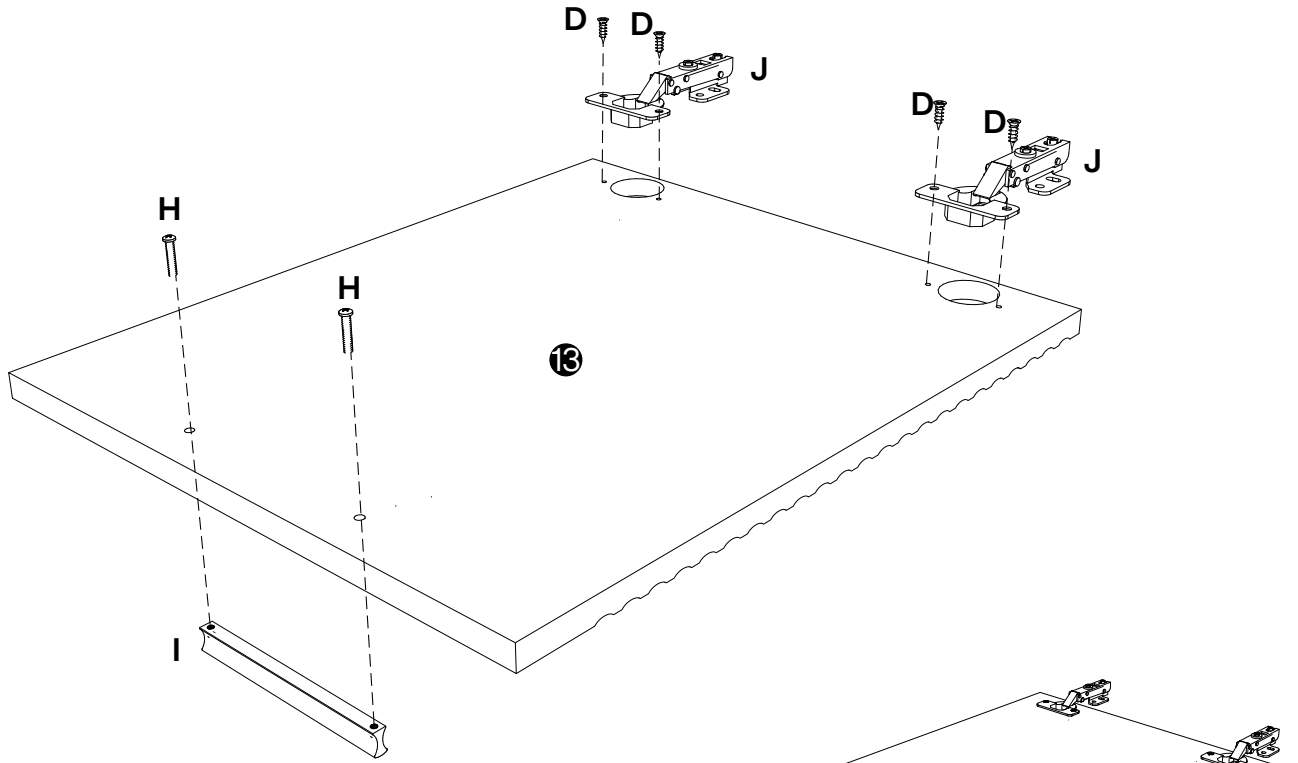

17

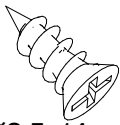

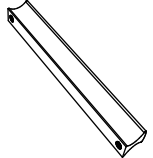
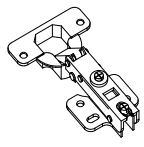

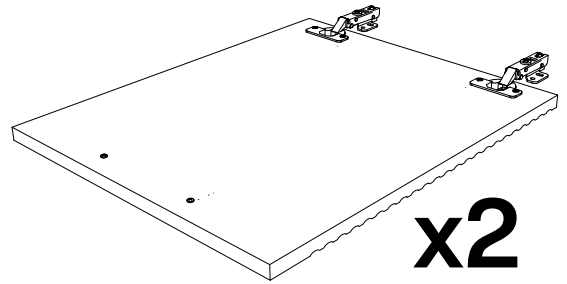
D	H	I	J
			
Ø3.5x14mm	M4x18mm		
8 pcs	4 pcs	2 pcs	4 pcs

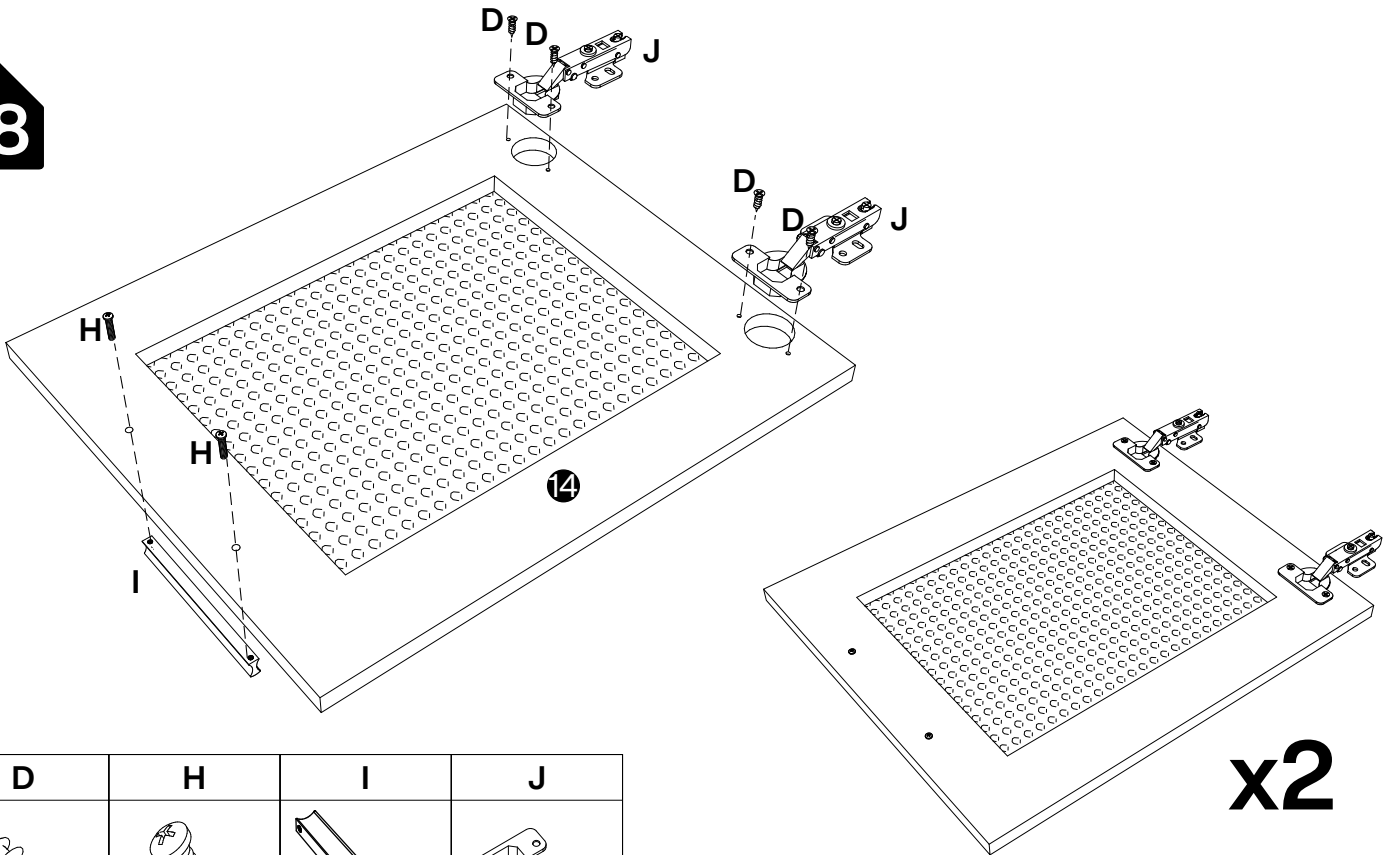

18

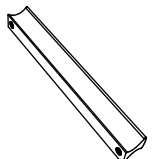
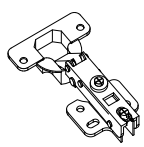

D	H	I	J
			
Ø3.5x14mm	M4x18mm		
8 pcs	4 pcs	2 pcs	4 pcs

x2

19

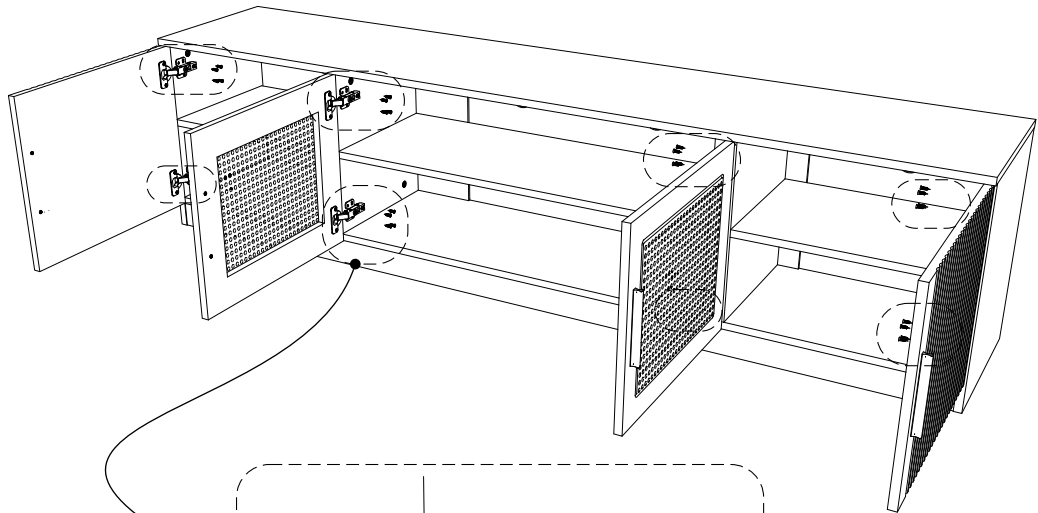

D

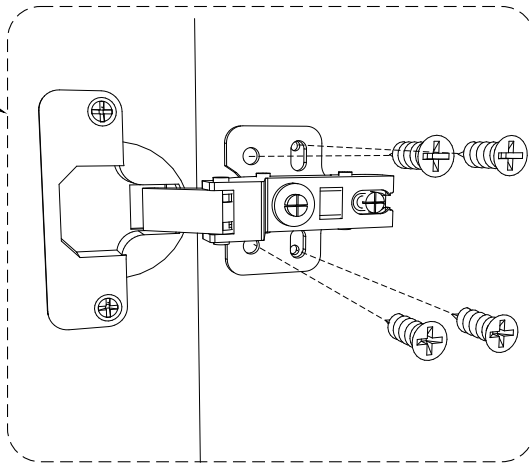
Ø3.5x14mm
32 pcs



To prevent the door hinge from falling off, please install 4 screws

20

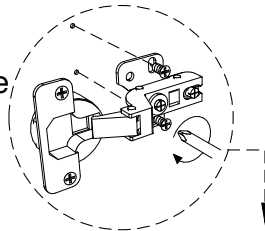
Please first install the two screws located near the interior of the cabinet



After completing the adjustments, please install the remaining two self-tapping screws

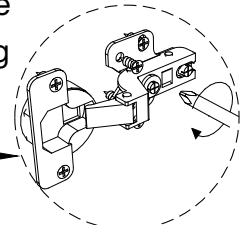

If there is misalignment after you install, adjust the screw to the best condition

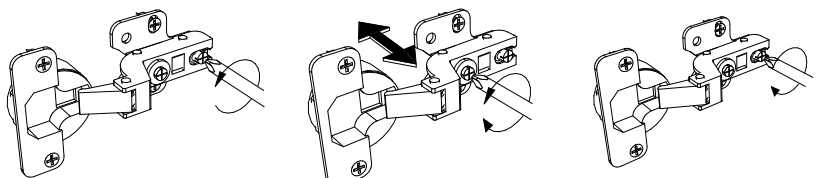
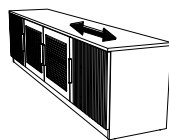
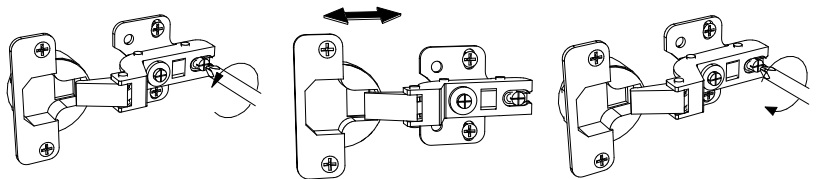
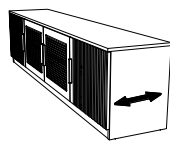
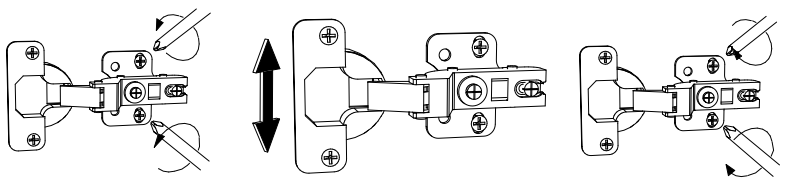
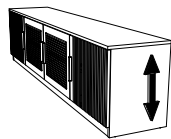

Thank you for your support!

