

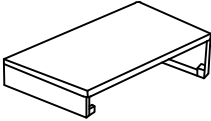

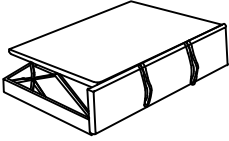

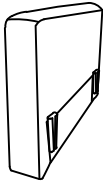

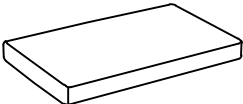
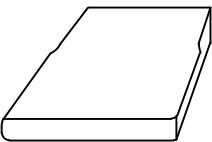
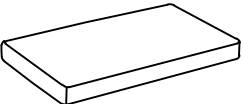

# Installation & Assembly

## Accessories list (sitting sofa)

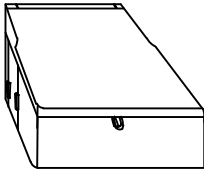
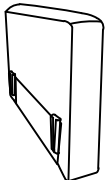
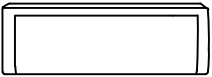
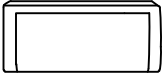
### Carton 1/2

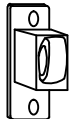
<p>A</p>  <p>2S seat frame(1)</p>	<p>B</p>  <p>lift up sofa frame(1)</p>	<p>R</p>  <p>Right armrest(1)</p>	<p>C</p>  <p>Backrest cushion(1)</p>
<p>D</p>  <p>Double seat cushion(1)</p>	<p>F</p>  <p>Lift up seat cushion(1)</p>	<p>G</p>  <p>Seat cushion(1)</p>	

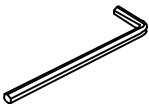
### Carton 2/2

<p>H</p>  <p>Chaise with storage(1)</p>	<p>L</p>  <p>Left armrest(1)</p>	<p>I</p>  <p>Right backrest(1)</p>	<p>J</p>  <p>Left backrest(1)</p>
<p>C</p>  <p>Backrest cushion(2)</p>	<p>K</p>  <p>Sofa leg(12)</p>	<p>M</p>  <p>Roller(4)</p>	<p>N</p>  <p>6×18 Screw(8)</p>
<p>O</p>  <p>M4×100×40 Wrench(1)</p>	<p>P</p>  <p>Latch(4)</p>		

STEP1: Install the legs to the right seat armrest and left seat armrest

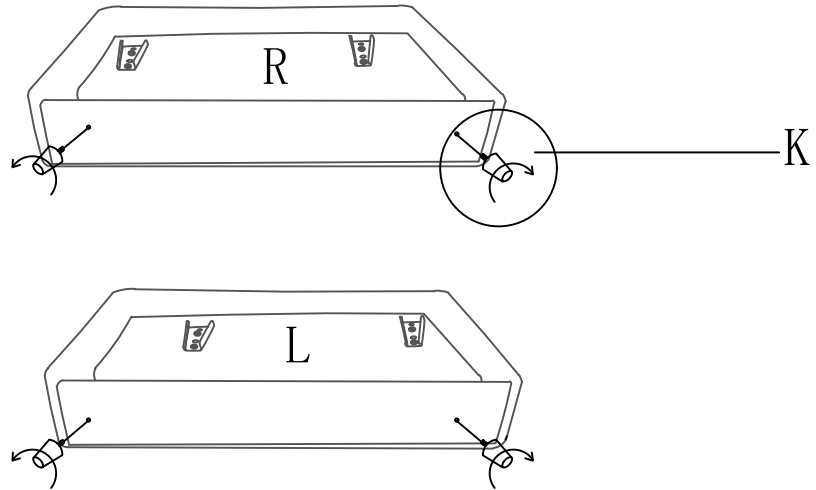

STEP2: Install the legs of sofa

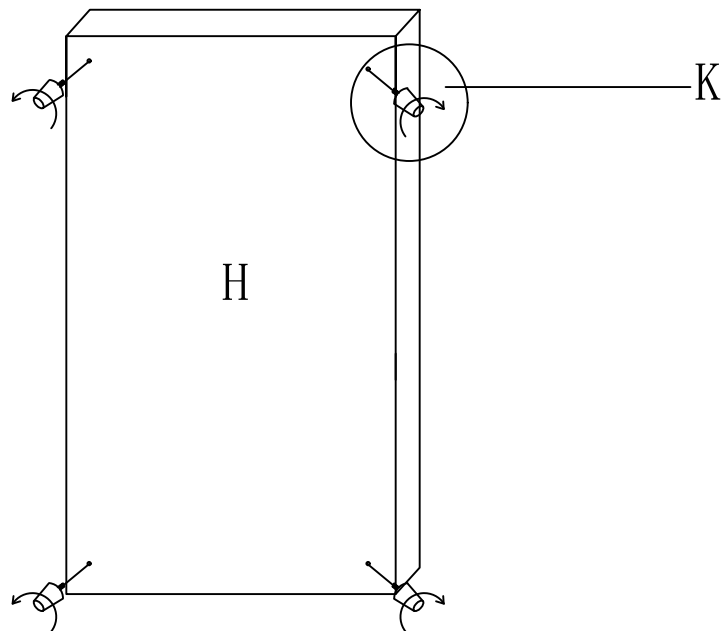

STEP3: Insert the backrest into the chaise with storage

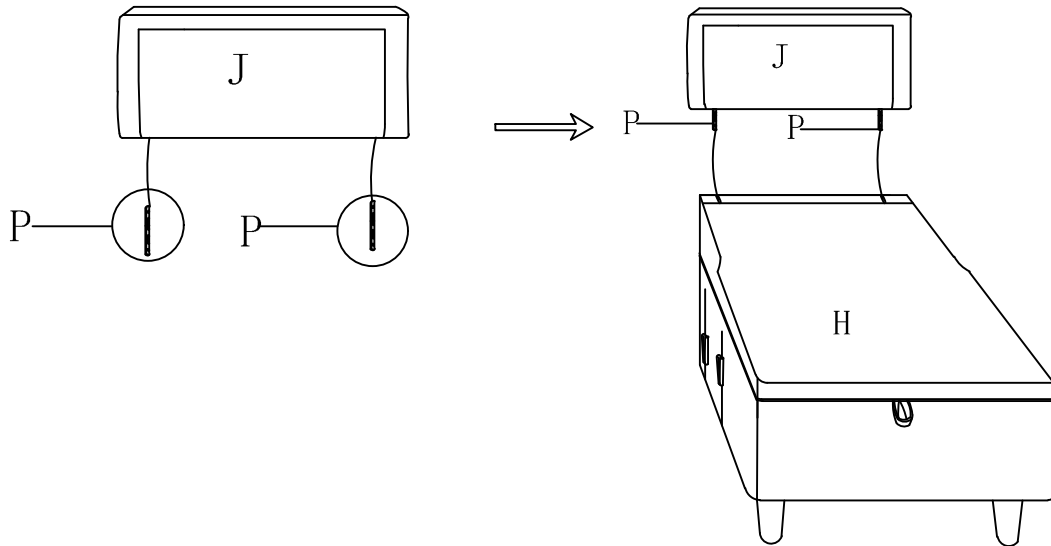

STEP4: Insert the left armrest into the chaise with storage

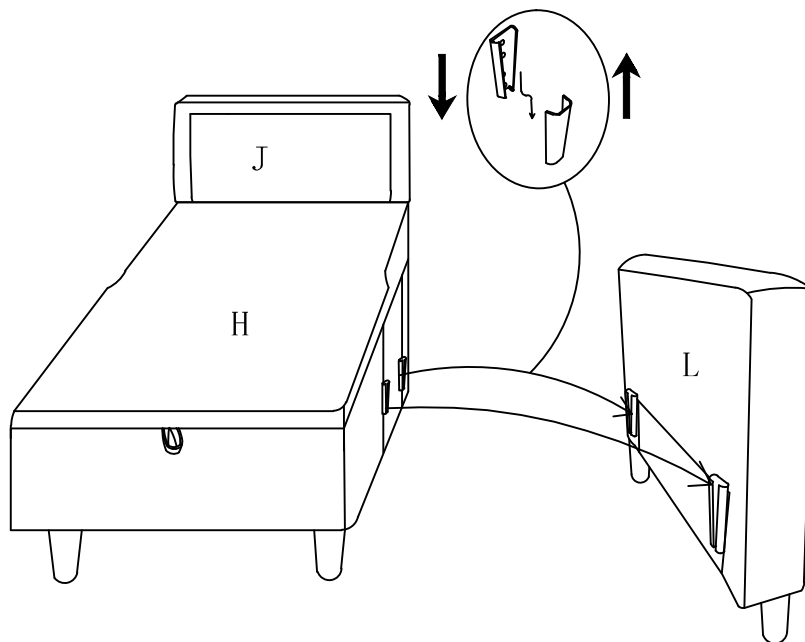

STEP5: Install the sofa legs to the 2s seat frame

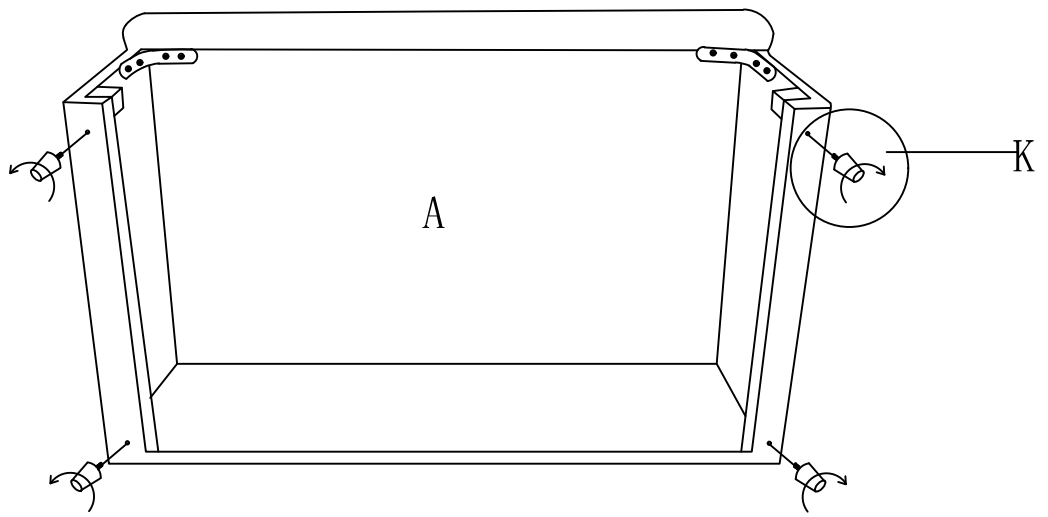

STEP6: Turn over the lift up sofa frame and install the roller

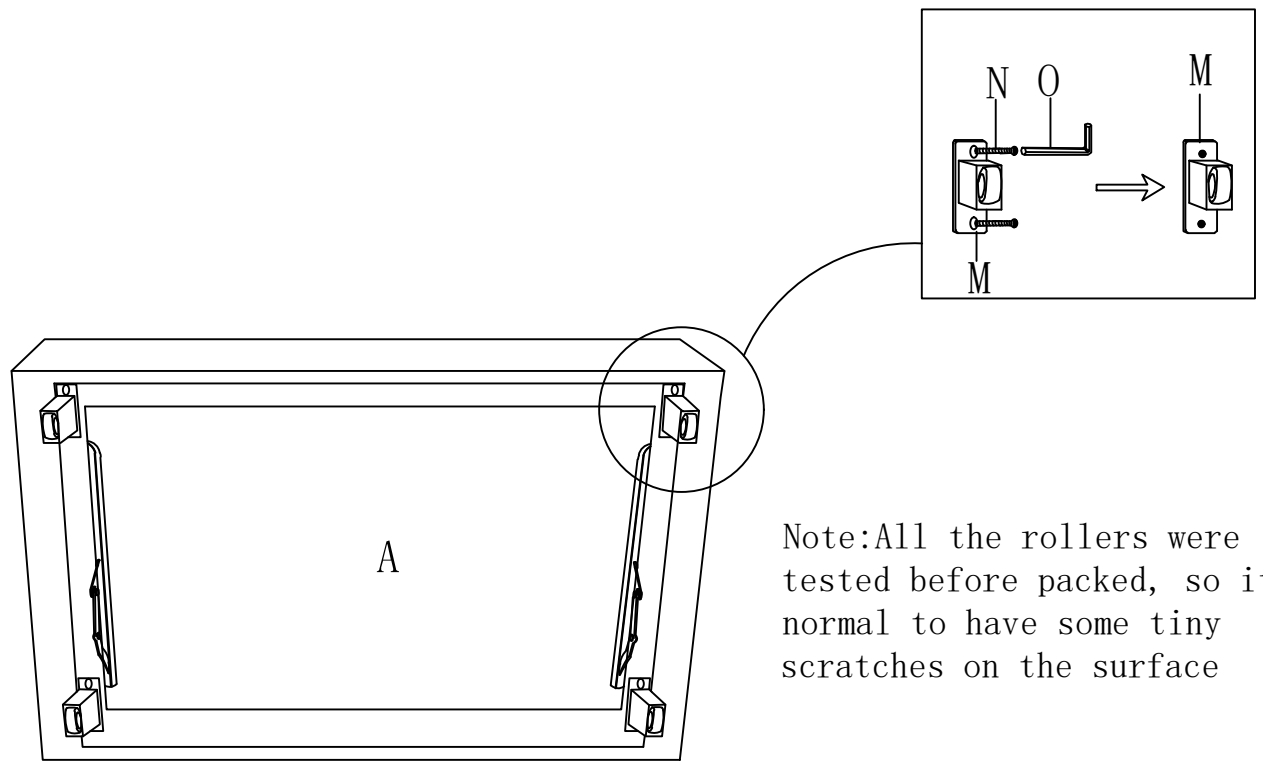

Note: All the rollers were tested before packed, so it's normal to have some tiny scratches on the surface

STEP7: Lift from sides and push it into the space under

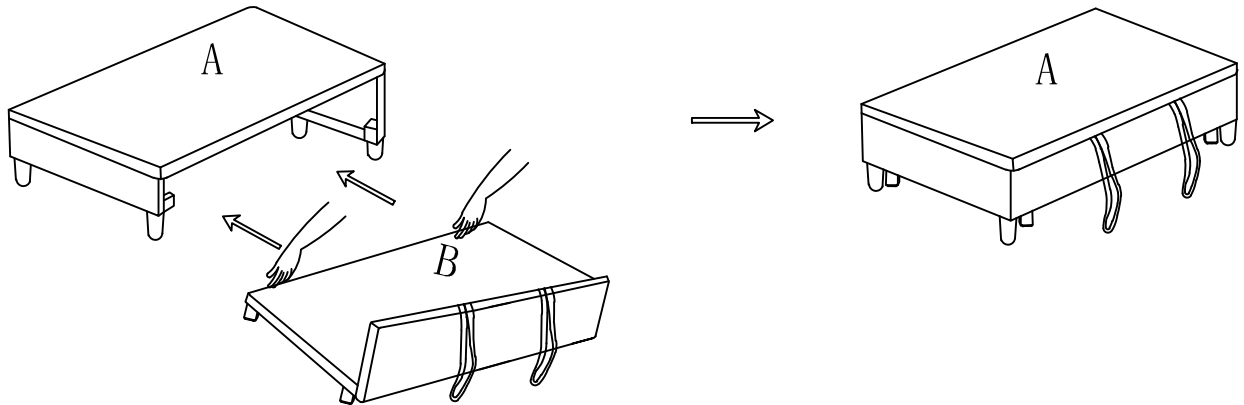

STEP8: Insert the latch into the backrest first, then insert the backrest into the sofa frame

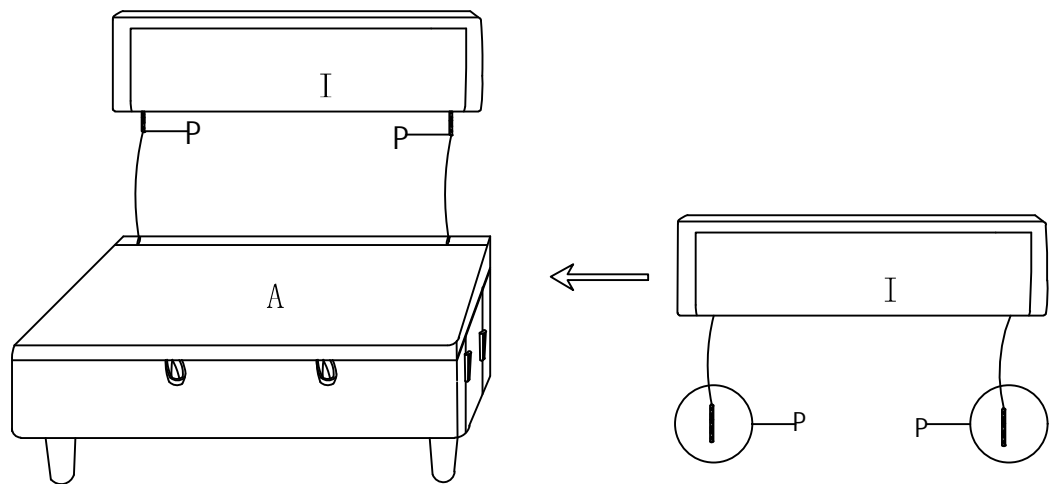

STEP9: Insert the right armrest into the 2S seat frame

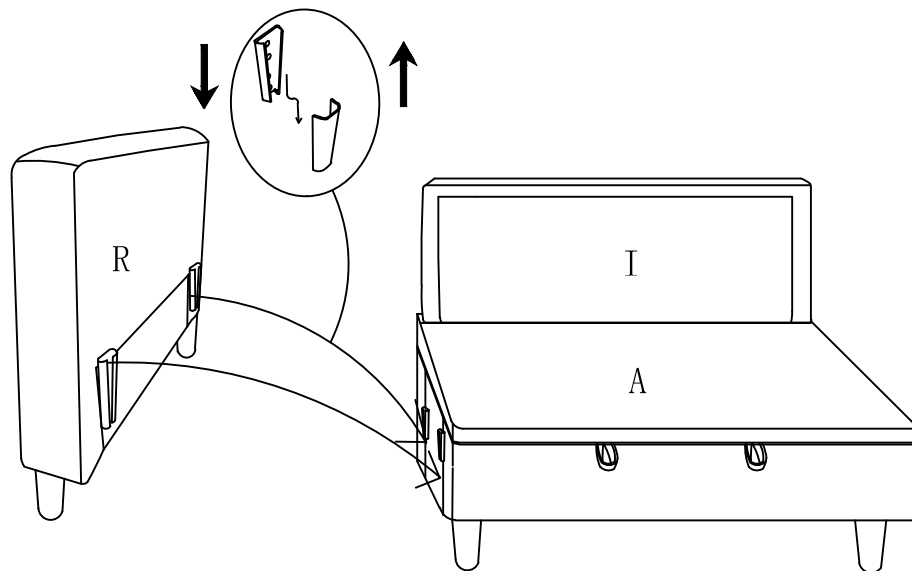

STEP10: Insert the 2 seat frame into the chaise with storage

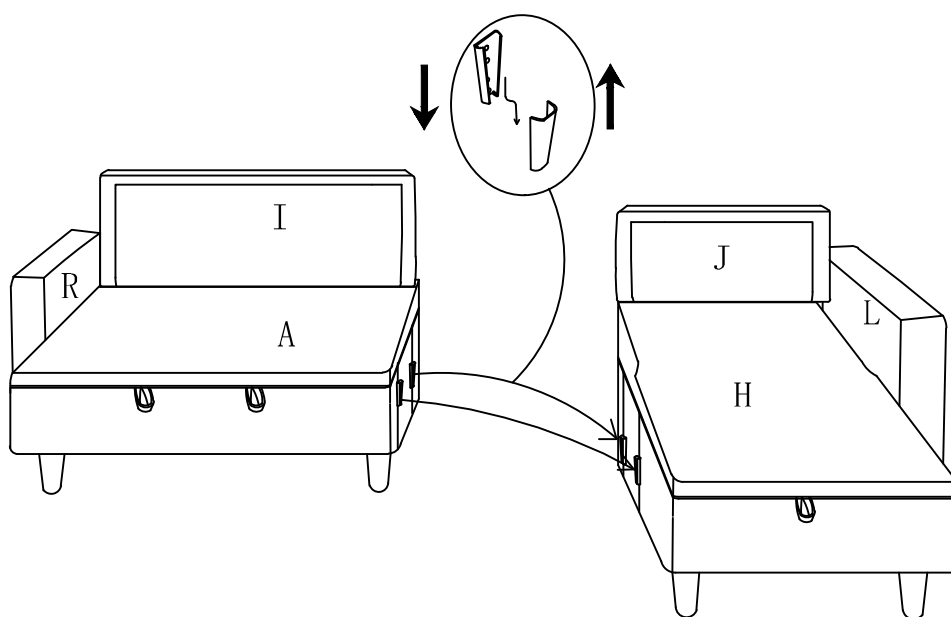

STEP11: Cut the compression bags

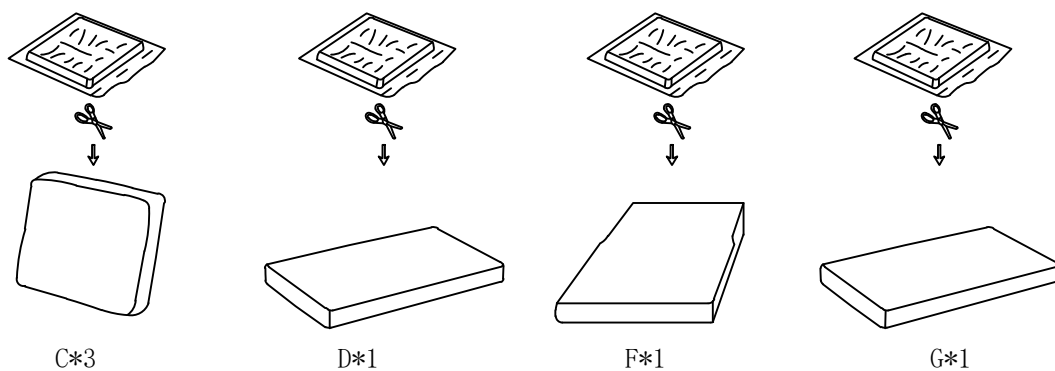

STEP12: Assembly completed

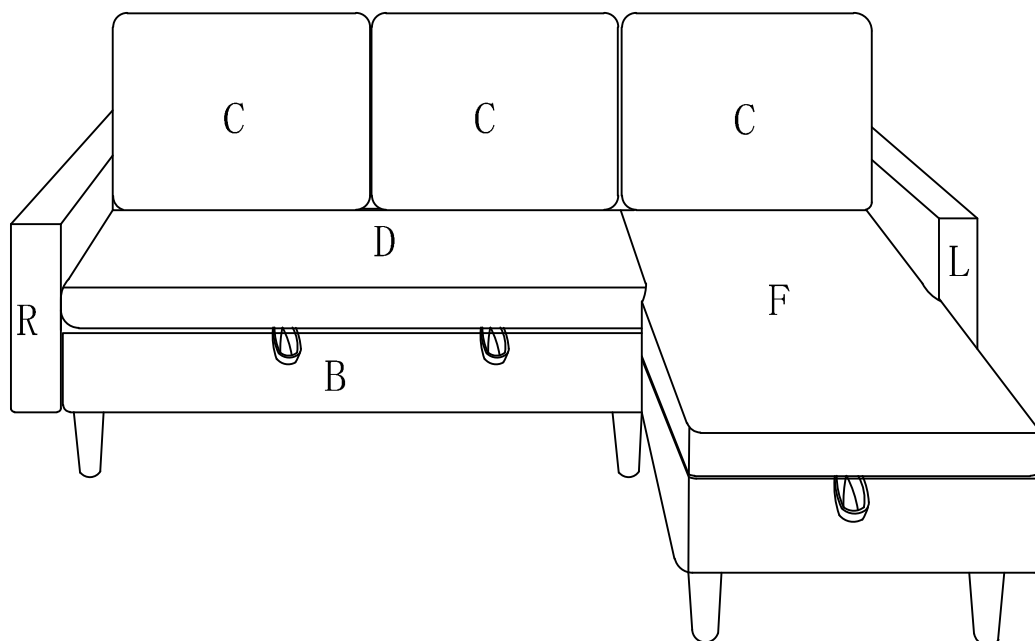

STEP13: Ways to get the sofa bed

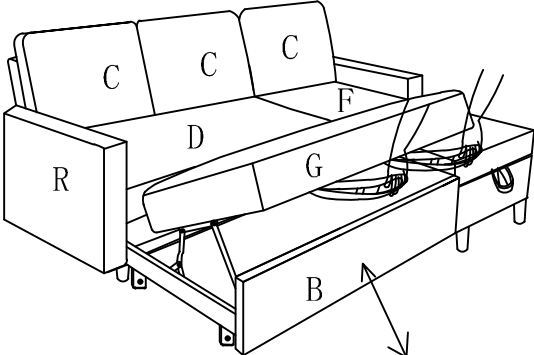
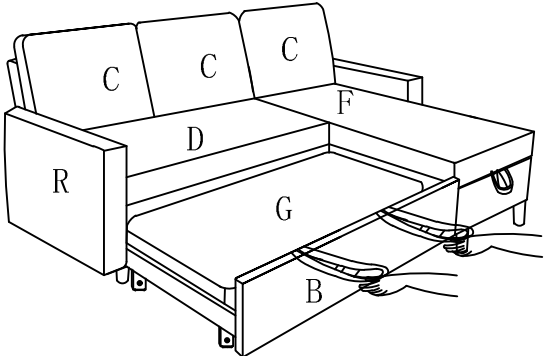

Pull the band up to the very end till you hear the seat sticks

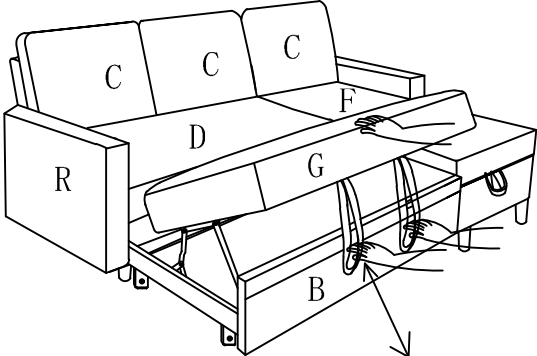

then push it down at the edge vertically

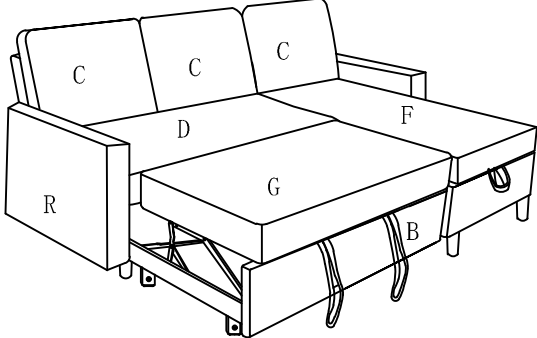

STEP14: Tips to open right seat frame A:  
Use one hand to hold down the seat when the other hand is lifting it up to avoid possible injuries.

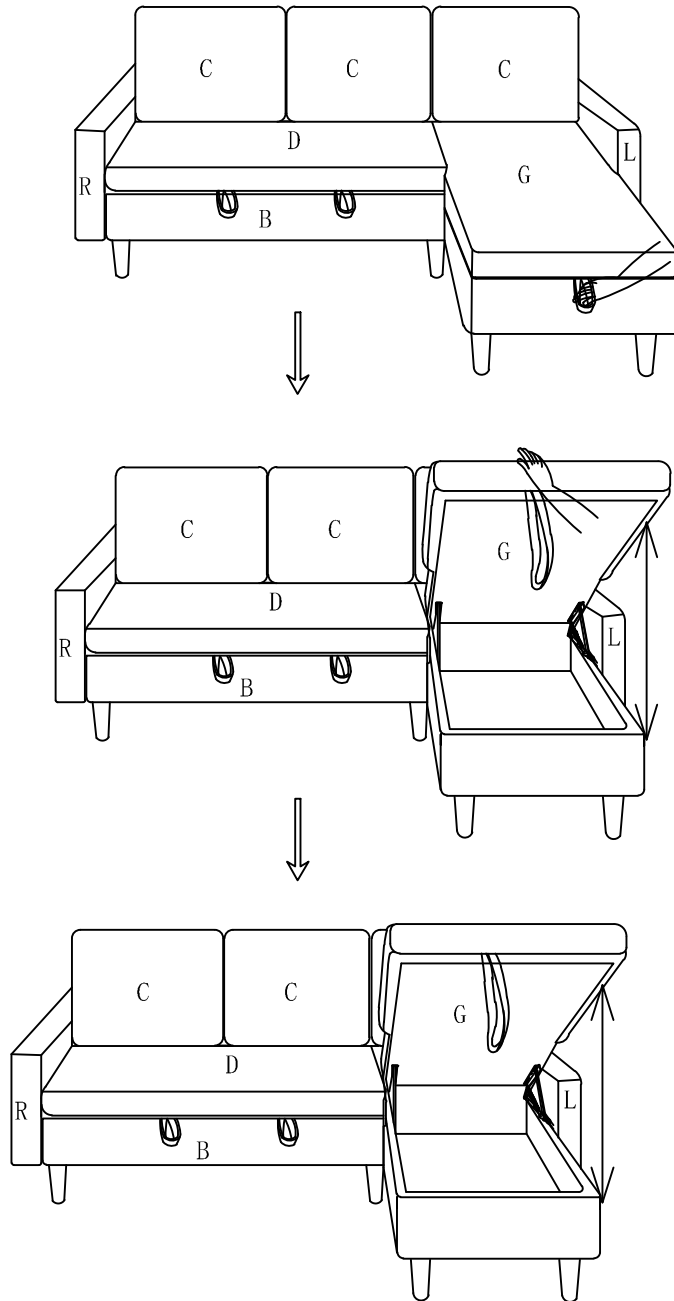

STEP15: The second installation method

1. Remove the arms on the left and right sides of the sofa
2. Remove the link between the storage sofa and the double sofa and reinstall it

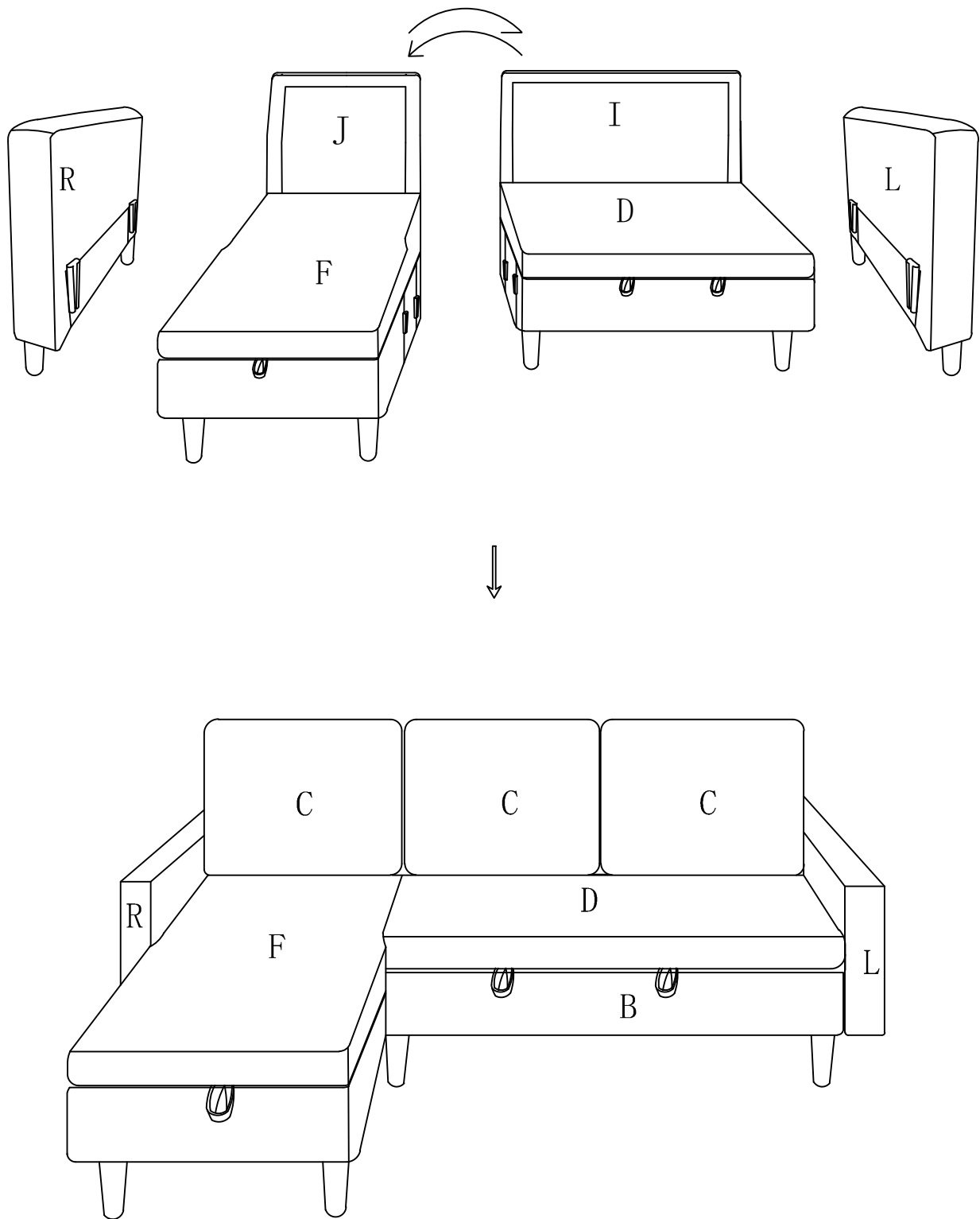

# STEP16: Ways to get the sofa bed

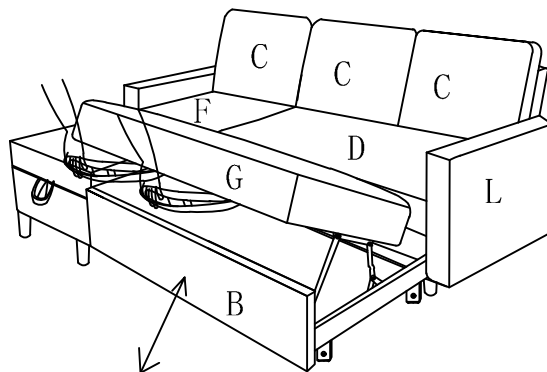
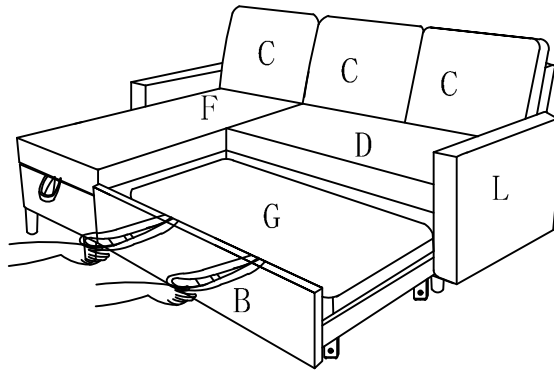

Pull the band up to the very end till you hear the seat sticks

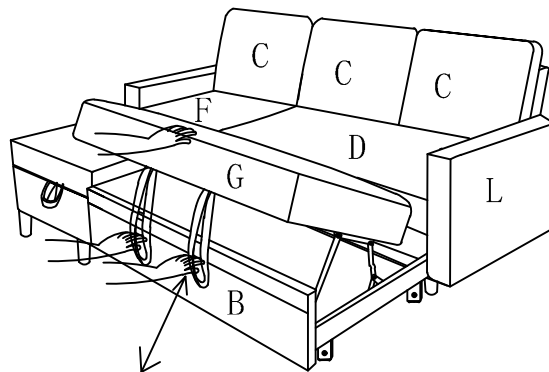

then push it down at the edge vertically

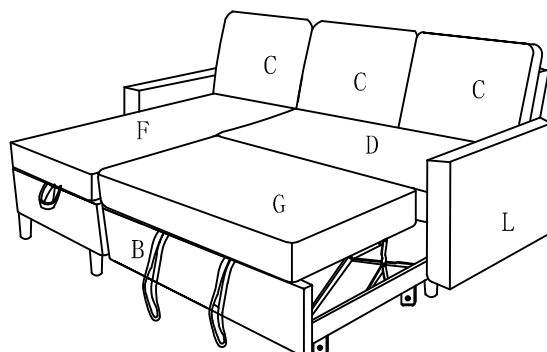

**STEP17:** Tips to open right seat frame A:  
Use one hand to hold down the seat when the other hand is lifting it up to avoid possible injuries.

