



Item#: MOR950CS/ MOR950CC

Description: Morrison Pw/ Pw Recliner Chair STONE/ CAMEL

Product Size: 36" × 40.5" × 41"H

Your furniture purchase is an investment. Here are a few tips to maximize the lifetime of your furniture with a minimum amount of effort. Properly caring for furniture can help ensure that it looks great year after year.

Wood Furniture Maintenance:

- Always dust, wipe, and clean *with* the grain of the wood.
- Dust with a soft cloth. Dust will scratch the furniture surface if not removed properly.
- Use the same type of polish consistently as interchanging oil-based and wax-based polishes will cause a build-up and result in a foggy or cloudy appearance.
- If a polished surface becomes foggy, rub it with a cloth dipped in a solution of one tablespoon vinegar to one quart of water. Rub softly with the grain until the surface is completely dry.
- Soap and water are not advisable for wood surfaces. Water can penetrate the finish and raise the grain on wood, causing damage.
- Remember to change dusting cloths frequently as dirty cloths may scratch your furniture's surface.

The Enemies of Wood:

- Moisture is wood's worst enemy. Liquid spills should be gently wiped up immediately. Coasters should be used under all beverages.
- Do not allow rubber or vinyl materials to lie on the furniture. Chemicals in rubber may leave a stain. Put a strip of felt or leather under accessories that have rubber or vinyl.
- Heat creates a chemical change in the furniture's finish, which results in a white spot. Use protective pads under hot dishes, appliances, etc.
- Sunlight's ultraviolet rays can damage the finish of furniture. Do not place furniture directly against a heater or radiator and do not place in the path of hot streams of air from central heating. This will cause extreme localized drying of the wood.

High Gloss Resin Table Maintenance:

- Resin tabletops have approximately 1/8" of a resin coat on the top face of the table, which will resist ice, water, wine, liquor, food, cleaning fluids, and warm or hot liquids; however, cups, glasses, etc. containing hot liquids should not be left on the table without a coaster for protection.
- Resin tabletops will scratch just the same as any other glossy surface and basic precautions should be taken.
- For lasting shine, the resin table should be waxed with a car wax that does not contain silicon. Maintaining this wax build-up will result in a high gloss shine.
- When wiping down the table, a soft, clean rag should be used. Do not use a heavy paper.

Granite Top Maintenance:

The surface of the granite on your table has been polished or sealed to create a generally non-porous surface. The stone has many natural characteristics including: veining, hairline cracks, and color variations - which make up the stone's beauty.

To maintain the beauty of your granite:

- Protect surfaces from scratching, staining and etching by:
 - * Keeping them free of debris or sharp objects
 - * Wiping up spills immediately
 - * Avoiding contact with chemicals (particularly acid-based materials)
- Clean with pH neutral products or those especially formulated for use on stone.
- It is not recommended to use a water-based solvent for dark granite as it will remove the polish from the surface.
 - absorbed into the stone.
- After a period of use, apply a penetrating sealer to prevent contaminants from being
- Remove stains with special absorbent poultices formulated for use on stone.
- Renew the surface on polished granite (granite with a high gloss surface) by buffing with special stone polish, powder or cream.
 - Do not use granite polish on granite with a matte finish, which has been honed rather than polished. (Penetrating sealer may be used on both polished and honed granite.)





Marble Top Maintenance:

Marble may be stone, but it is porous stone and can stain easily. Treating marble surfaces the same as wood surfaces is a great rule of thumb.

- It is recommended to seal the tops on a regular basis (every 6 to 12 months). A good quality stone sealer can be purchased from any tiles/stone store or any homecare store and should be applied according to the manufacturer's recommendation.
- When sealed properly, marble tops can be used indoors and outdoors and can withstand any weather conditions except internal freezing. Snow or freezing rain will penetrate the table and cause cracks.

Caring for the Fabric on Upholstered Furniture:

- Frequent vacuuming of the entire upholstered area will prevent dust from settling into the fibers.
- Professional cleaning is always recommended for all upholstered pieces.
- Always pre-test a small area of fabric in an inconspicuous area when cleaning before proceeding.
- Do not use cleaning products containing brightening agents.

VERY IMPORTANT!!			
<p>NEVER USE GLASS CLEANERS ON FINISHED SURFACES. AMMONIA WILL CHEMICALLY ATTACK THE FINISH.</p>	<p>DO NOT WRITE DIRECTLY ON SURFACE</p>  <p>PREVENT MARKING</p>	<p>DO NOT PLACE DIRECTLY IN SUNLIGHT</p>  <p>PREVENT FADING</p>	<p>DO NOT USE PLACEMATS WITH RUBBER BASES</p>  <p>PREVENT DISCOLORING</p>
<p>NEVER ALLOW LIQUIDS OF ANY KIND TO LINGER ON SURFACES. ABSORPTION CAUSES THE WOOD TO WARP AND THE FINISH TO DE-LAMINATE.</p>	<p>DO NOT USE COMMERCIAL POLISHES AND WAXES</p>  <p>PREVENT YELLOWING</p>	<p>DO NOT PLACE HOT POTS, ETC. ON SURFACE</p>  <p>PREVENT DAMAGE TO FINISH!</p>	<p>REGULATE THE HUMIDITY CONDITIONS AT YOUR HOME</p>  <p>PREVENT SPLITTING</p>

MOR950CS/ MOR950CC ASSEMBLY INSTRUCTIONS

CAUTION: PLEASE READ ALL INSTRUCTIONS CAREFULLY BEFORE STARTING ASSEMBLY PROCESS. IT IS RECOMMENDED TO USE TWO PEOPLE WHEN ASSEMBLING AND REMOVING THE INSIDE BACKS TO AND FROM THE BASE OF THE FURNITURE.

STEP 1: Attached to the top of the swivel base is the hardware bag that includes the power transformer, power cord and power transformer extension cord. Remove the parts from the bag and attach the power cord to the transformer and the power transformer extension cord to the matching end coming from the power transformer. Make sure to close the clip lock to prevent the connection from coming loose during use. Set the assembly aside to be used in step 5.

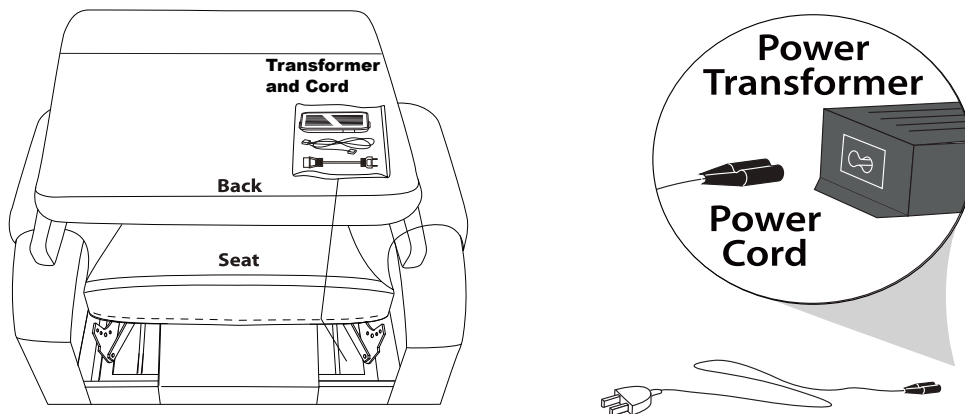

STEP 2: Attaching the Recliner Back: Position the KD back(A) with the KD receivers positioned over the mechanism post on the recliner body (B) as pictured below. Check to assure both sides of the mechanism post are positioned inside of the KD receivers on the back frame, push in a downward motion from the top of the back frame until a clicking sound is heard.

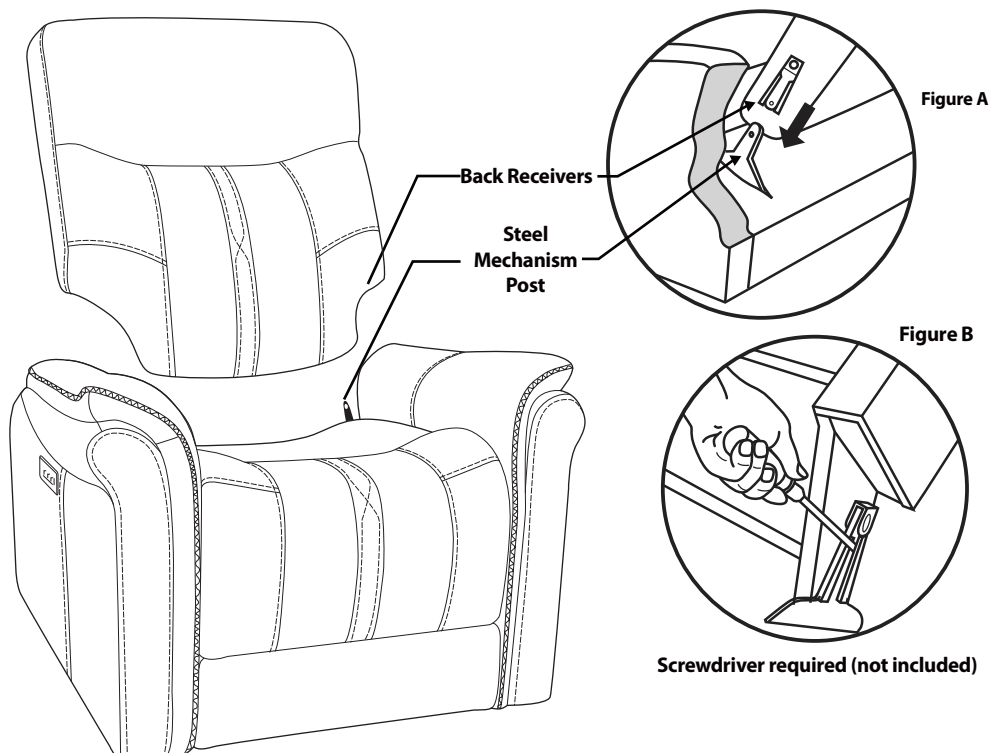

STEP 3: Slide the metal inserts on recliner's Left wing(C)and Right wing (D) into the metal sleeves on the side of the recliner's back. Slide the wings down until they are completely set on the backs metal sleeves.

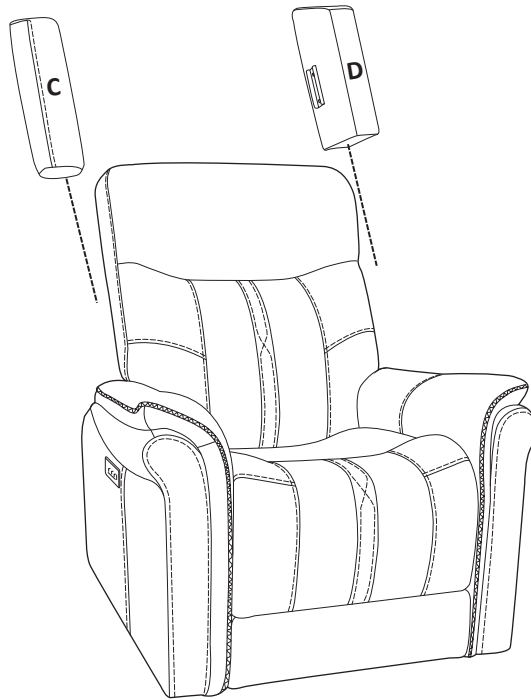

STEP 4: Attach the leadwires found at the bottom of motion back to the leadwires at the rear of seat. Yellow to Yellow. Make sure to close the clip locks to assure the connections will not come loose during use.

The headrest leadwires are color coded and labeled Headrest.



STEP 5: Attach the outside back across the bottom rear of each seat rail with the pre attached Velcro.

TOOLS REQUIRED : NO TOOLS REQUIRED

PART LIST

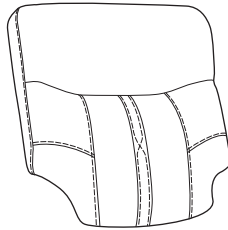
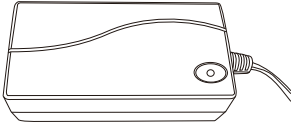
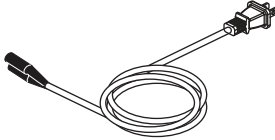
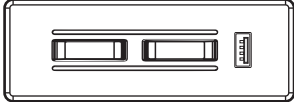
NO	Description	Sketch	Quantity
A	PMOR950CSB PMOR950CCB		1
B	PMOR950CST PMOR950CCT		1
C	PMOR950CSPC PMOR950CCPC		1
D	PMOR950SC		1

Spare part for MOR950CS/ MOR950CC

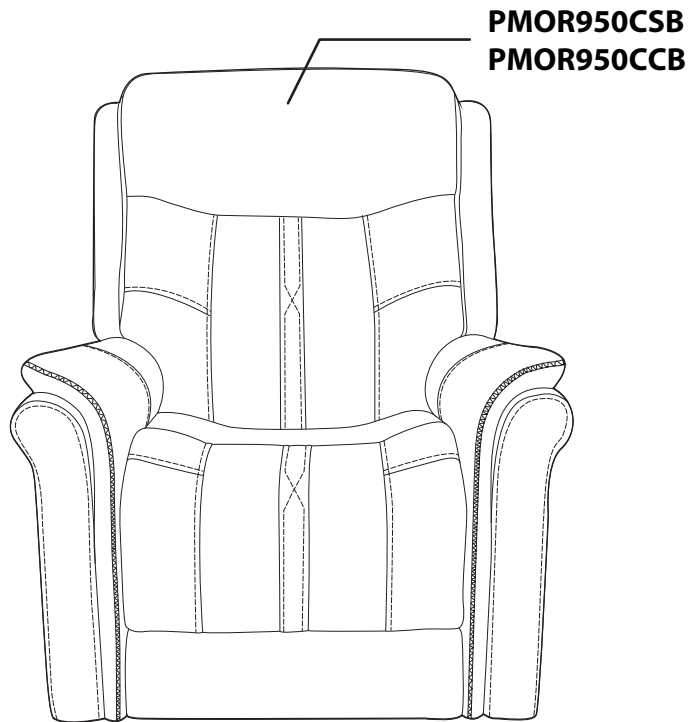

**PMOR950CST
PMOR950CCT**

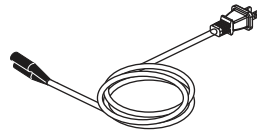

**PMOR950CSPC
PMOR950CCPC**



PMOR950SC

PRODUCT DETAILS

RECLINER CHAIR BODY	STEEL+PLYWOOD
PRODUCT SIZE	L 36" x W 40.5" x H 41"
CARTON SIZE	L 38.6" x W 30.3" x H 26"
SEAT HEIGHT	25.6"
SEAT DEPTH	20.9"
NET WEIGHT	118.9 LBS
GROSS WEIGHT	138.9 LBS
CU.FT.	17.6

FABRIC CONTENT: POLYESTER 100%
 FABRIC CONTENT: POLYESTER
 FRAME MATERIAL: WOOD & IRON
 FABRIC CLEANING CODE : S
 USER MANUAL : SOLVENT AND / OR WATER BASED CLEANERS
 This fabric is not machine washable.
 Allow +/-3% residual shrinkage.
 Do not use cleaning products containing brightening agents

SIDE CONTROL USER'S MANUAL

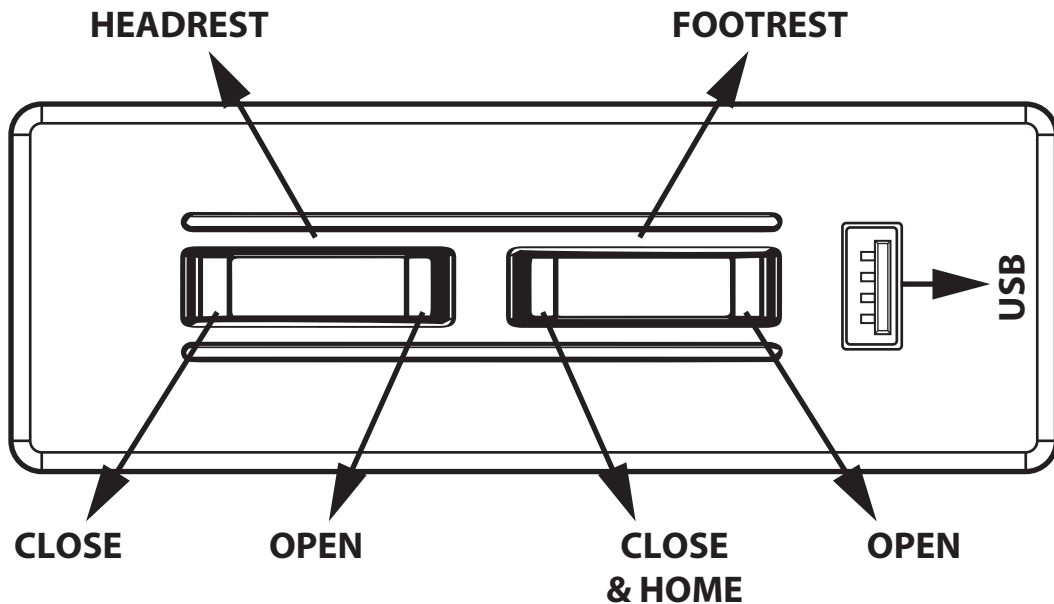

To recline: Sit on the furniture, and press the front of the button closest to the footrest to smoothly raise the footrest and recline to any position. To lower the footrest and return to an upright position, press the back side of the button closest to the footrest.

To adjust headrest: Press the front of the button closest to the backrest to smoothly raise and adjust the headrest to any position. To lower the headrest and return it to its original position, press the back side of the button closest to the backrest.

To close all: To simultaneously return the headrest, footrest, and lumbar support to their original positions, press and hold the back side of the button closest to the footrest.

Product Protected By Following Patents:
Patented Articulating Power Headrest
US Patent: 10,736,423

MADE IN VIETNAM