

STEP 4

TURN 90°

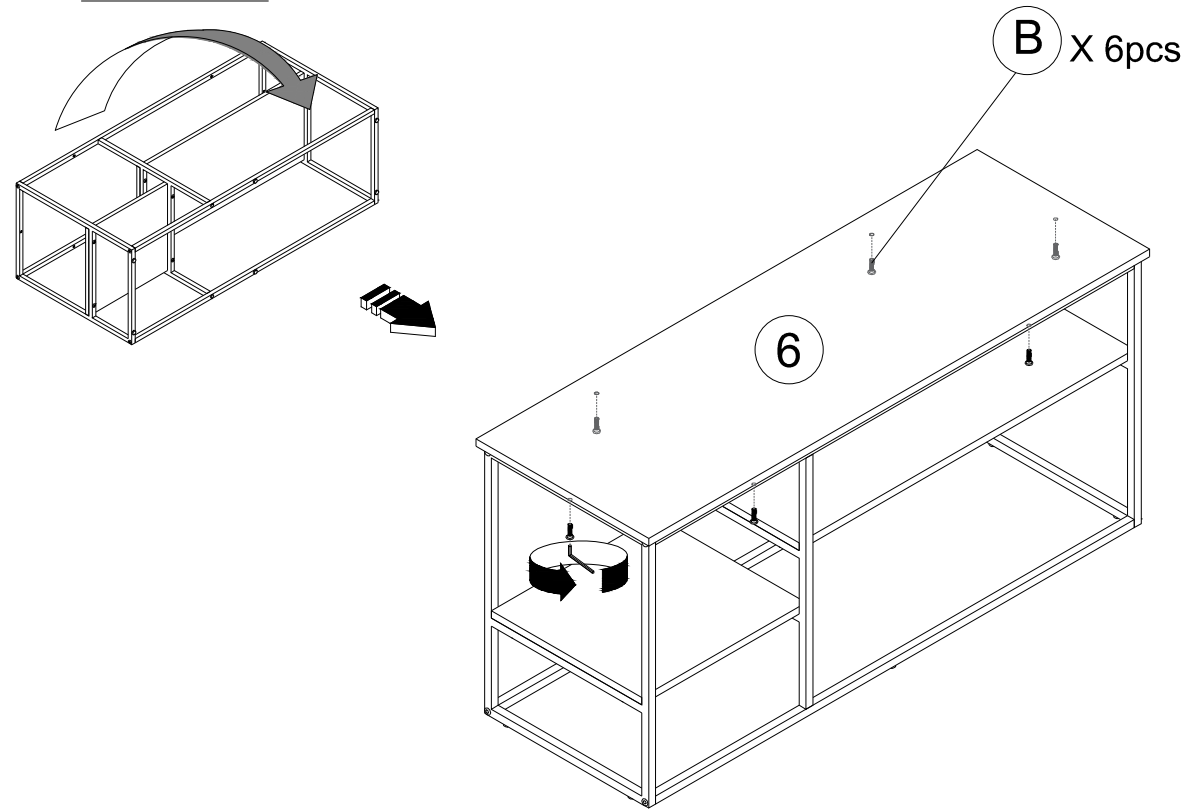

Recommended Maximum Weight

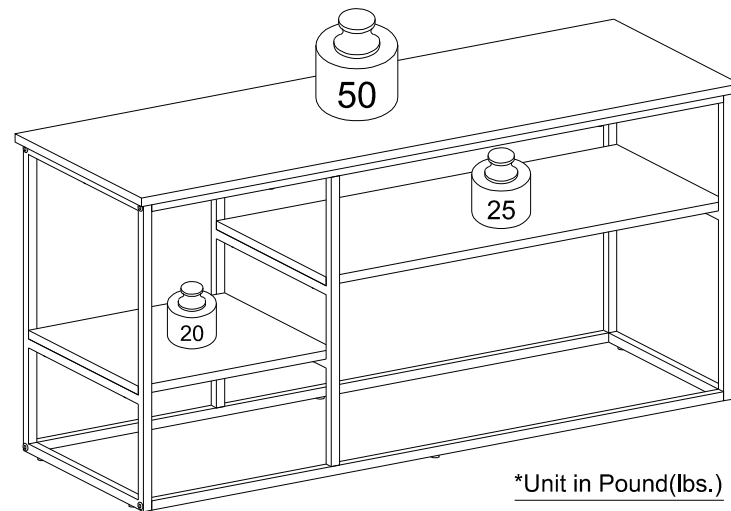

WARNING:

>This unit has been designed to support the maximum loads shown. Exceeding these load limits could cause sagging, instability, product collapse, and/or serious injury.

>DO NOT allow children to climb on unit.

00:30

Approx. 30 minutes

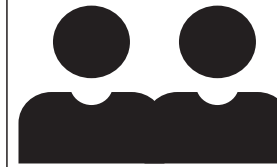

Recomm. 2 Persons





No Tools Required



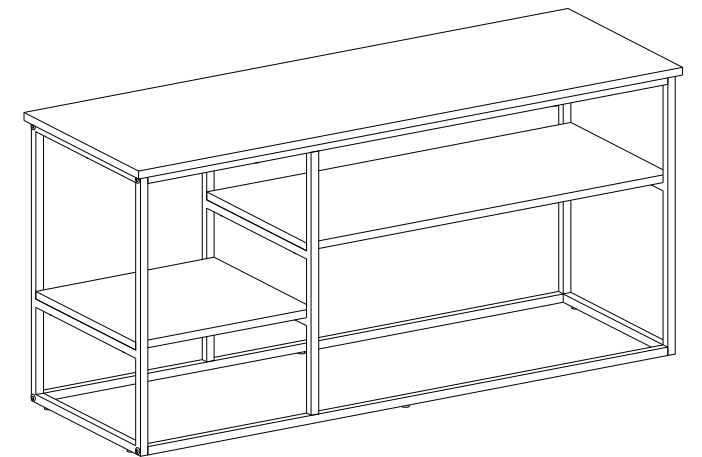





Assembly Instruction

TV Stand for TV up to 50 Inch



HARDWARE & PARTS LIST

NO	HARDWARE LIST	QTY
A	LONG SCREW 	8pcs
B	SHORT SCREW 	14pcs
C	FLAT HEAD SCREW 	4pcs
D	ALLEN KEY 	1pc
E	RUBBER STUD 	6pcs

NO	PARTS LIST	QTY
1	METAL FRAME A 	1pc
2	METAL FRAME B 	1pc
3	METAL FRAME C 	1pc
4	UPPER RAIL 	2pcs
5	BOTTOM RAIL 	2pcs
6	TOP PANEL 	1pc
7	LARGE SHELF PANEL 	1pc
8	SMALL SHELF PANEL 	1pc

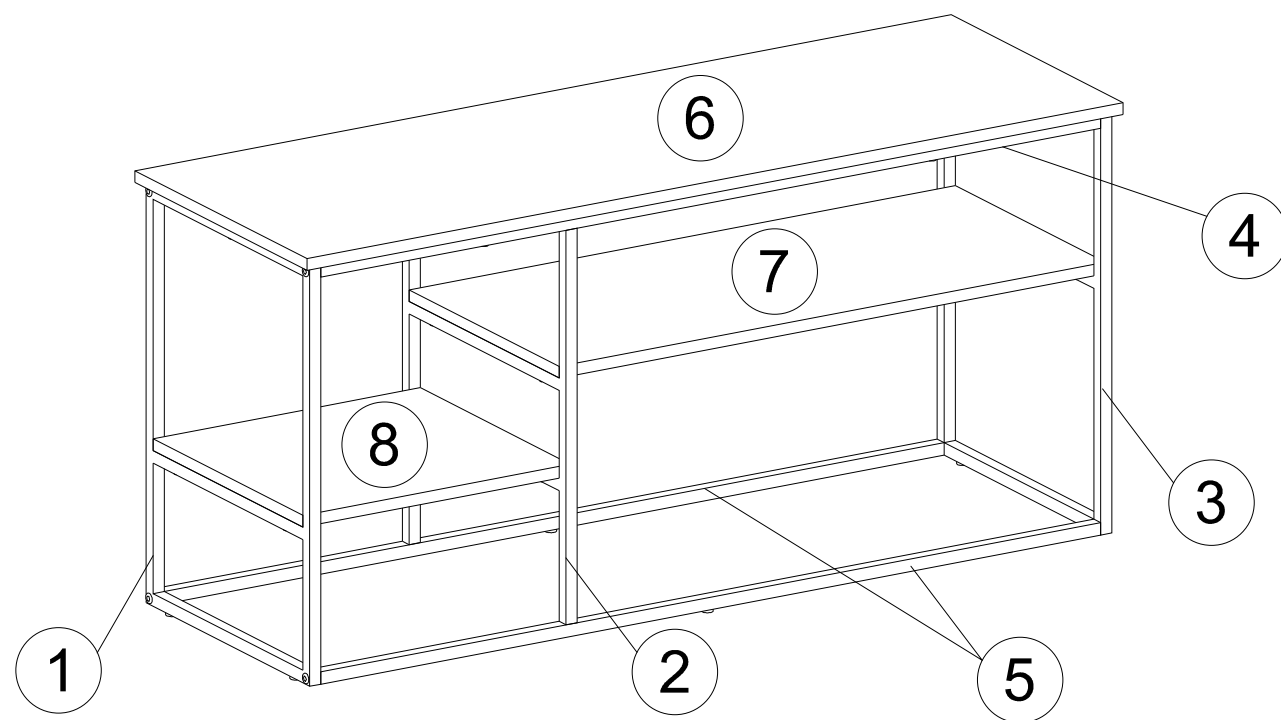

USEFUL HINTS BEFORE YOU START:

1. Read each step carefully before assembling.
2. It is important that each step is performed in correct order to avoid difficulties.
3. Identify, sort and count the parts before assembly.
4. Assemble your furniture on packaging cardboard to prevent scratch or damage.
5. Clean the product with mild cleanser using soft dampened cloth. Do not use harsh or abrasive cleanser.
6. Using incompatible hardware might cause damage to product.

ASSEMBLY INSTRUCTIONS

BEFORE YOU BEGIN, PLEASE READ ASSEMBLY INSTRUCTION CAREFULLY, FOLLOW THEM STEP BY STEP.

REMINDER: Please do not fully tighten any screw until all of them are in right positions.

