

# FULL/QUEEN/KING BED ASSEMBLY INSTRUCTIONS

## PARTS PACKING CONFIGURATIONS

### BOX #1:

- A. HEADBOARD 1 PC
- B. LEFT HEADBOARD LEG 1 PC
- C. RIGHT HEADBOARD LEG 1 PC
- D. STRETCHER 1 PC

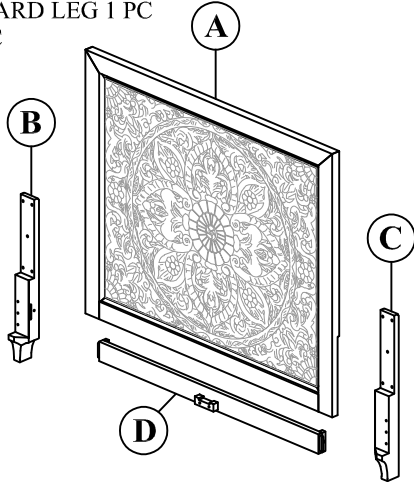

### BOX #2:

- E. FOOTBOARD 1 PC
- J. SLAT ROLL 1 SET

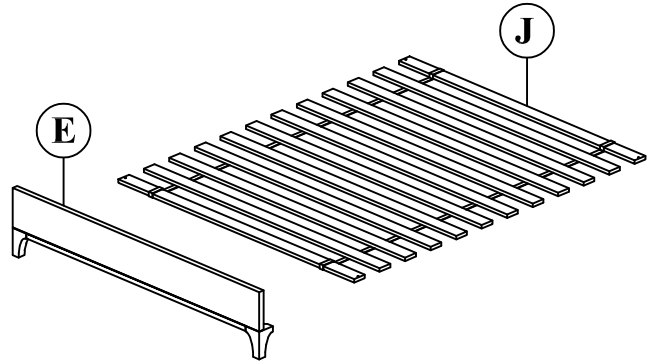

### BOX #3:

- F. LEFT SIDE RAIL 1 PC
- G. RIGHT SIDE RAIL 1 PC
- H. CENTER SLAT SUPPORT 1 PC
- I. SLAT SUPPORT LEG 3 PCS

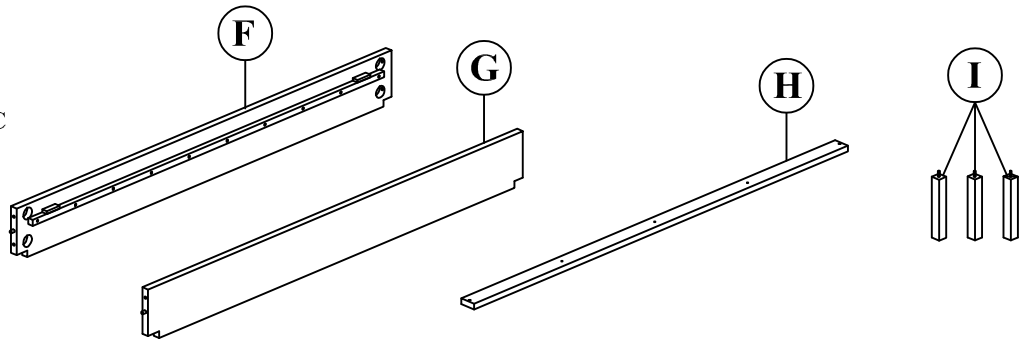

### HARDWARE KIT PACKED IN BOX #1

No.	Description	Image	Quantity
1	ALLEN BOLT (M8X40)		12 PCS
2	SPRING WASHER (M9)		12 PCS
3	FLAT WASHER (M9)		12 PCS
4	ALLEN KEY		1 PC

### HARDWARE KIT PACKED IN BOX #2

1	THREADED BOLT (M8X80)		8 PCS
2	HEX NUT (M8)		8 PCS
3	HALF MOON WASHER (M9)		8 PCS
4	WOOD SCREW (M4X30)		6 PCS
5	SPANNER		1 PC

### FULLY ASSEMBLED

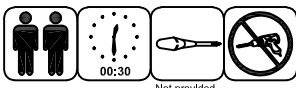

# FULL/QUEEN/KING BED ASSEMBLY INSTRUCTIONS

## STEP 1:

**NOTE: USE HARDWARE PACKED IN BOX #1 FOR STEPS 1 & 2.**

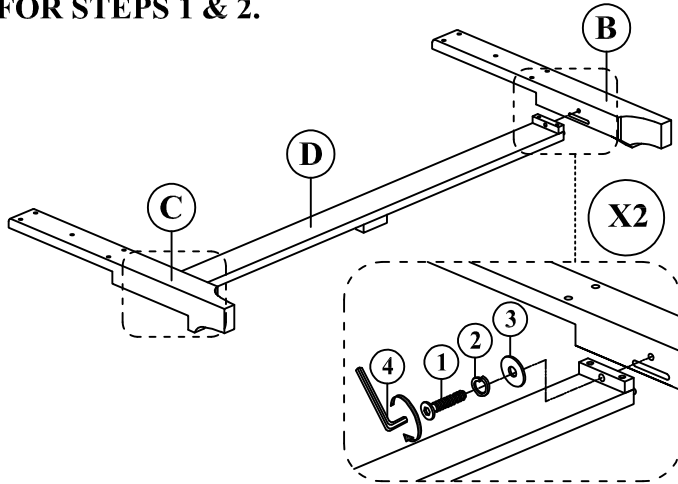

## STEP 2:

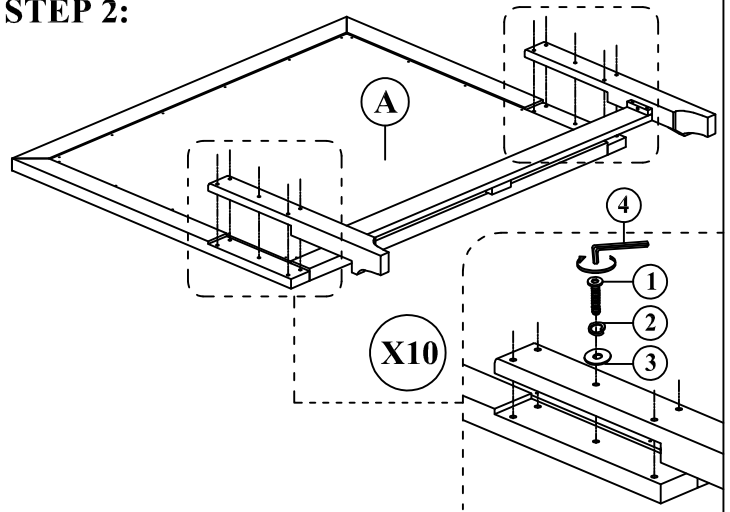

## STEP 3:

**NOTE: USE HARDWARE PACKED IN BOX #2 FOR STEPS 3 AND ALL THAT FOLLOW.**

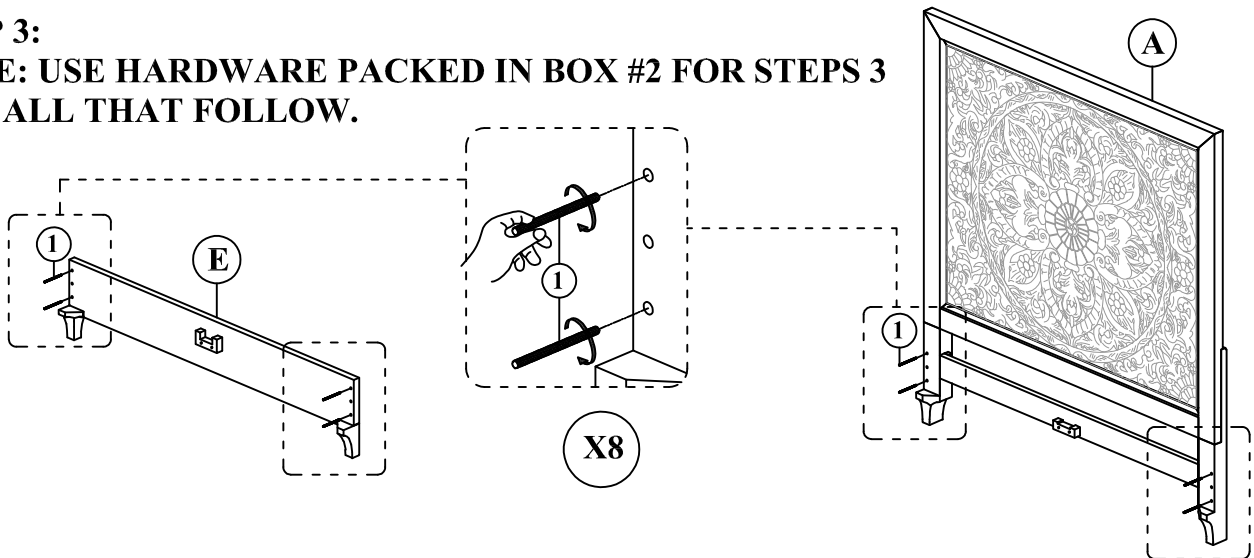

## STEP 4:

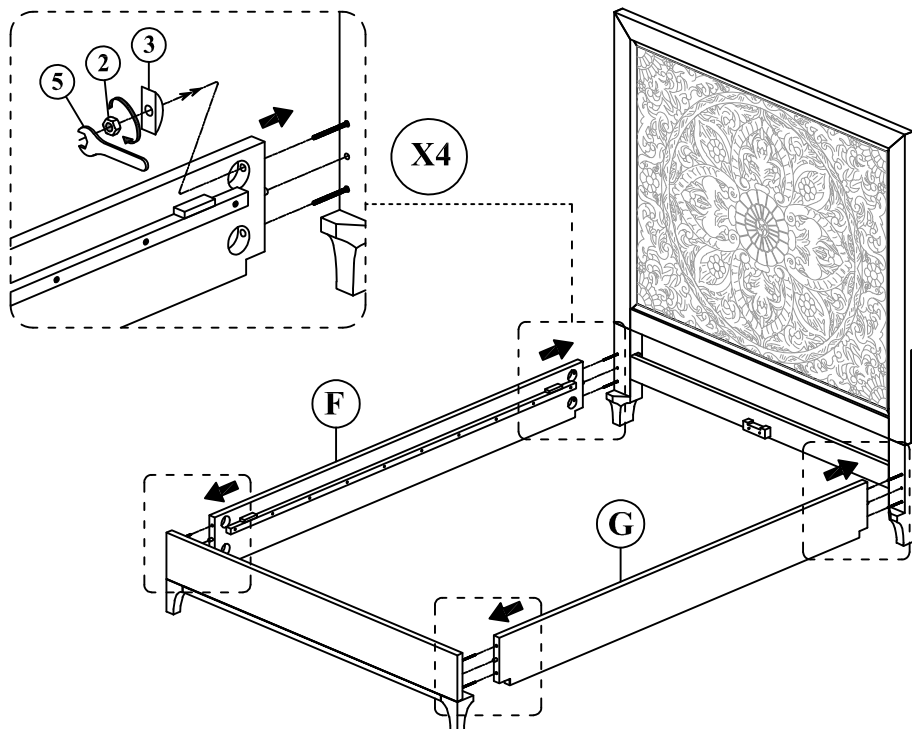

# FULL/QUEEN/KING BED ASSEMBLY INSTRUCTIONS

## STEP 5:

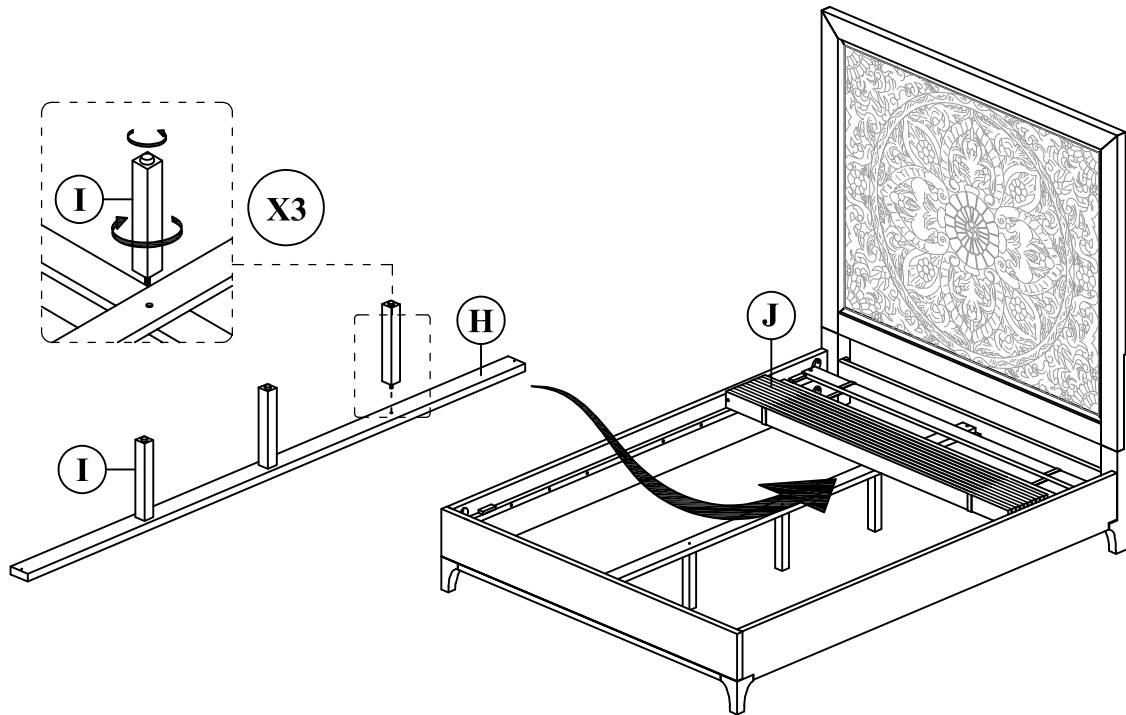

## STEP 6:

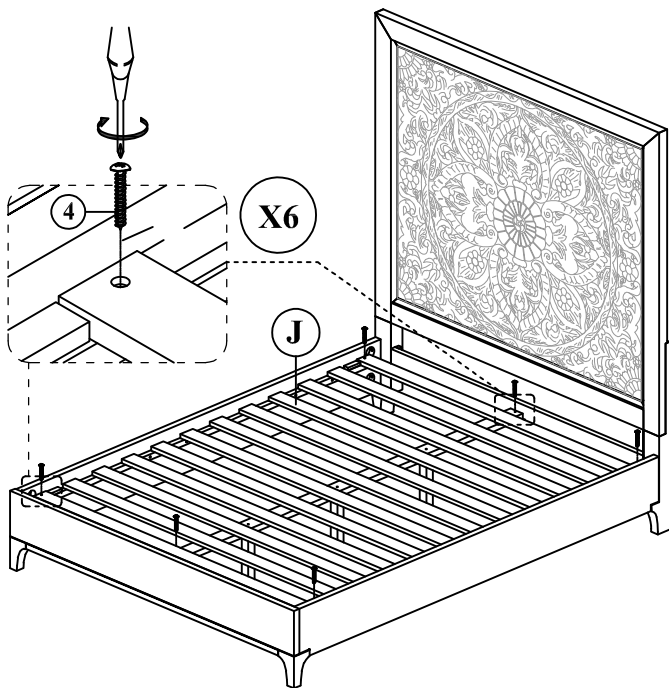

## STEP 7:

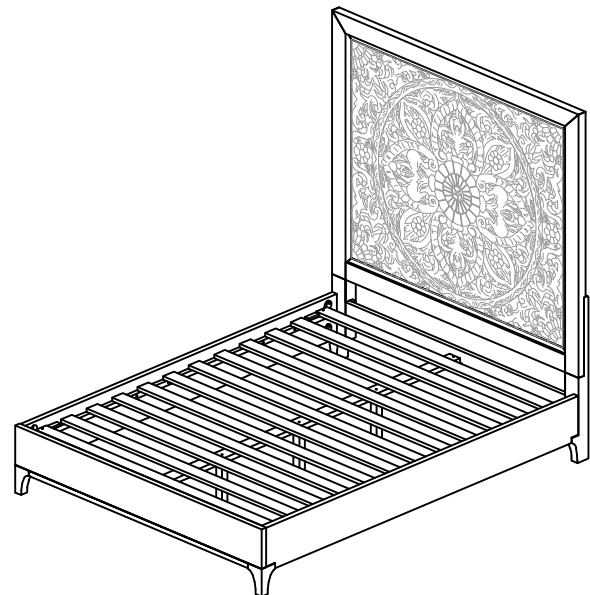

ASSEMBLY COMPLETE

### INSTRUCTIONS FOR ADJUSTING LEVELER

POSITION THE BED IN YOUR SPACE AND LOCATE THE LEVELER UNDER EACH SUPPORT LEG. TURN THE LEVELER COUNTER-CLOCKWISE TO EXTEND THE LEVELER AND CLOCKWISE TO RETRACT IT.

ADJUST EACH LEVELER UNTIL EACH SUPPORT LEG IS APPLYING EQUAL, UPWARD PRESSURE ON THE SUPPORT SLAT.

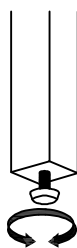

### MAINTENANCE INSTRUCTIONS:

PERIODICALLY CHECK ALL FITTINGS AND TIGHTEN IF NECESSARY, AS THEY CAN LOOSEN OVER TIME.

ALWAYS REMOVE BOX SPRING AND MATTRESS BEFORE MOVING THE BED.

LIFT THE BED WHEN MOVING IT. DRAGGING THE BED CAN DAMAGE THE CENTER SUPPORT.

READJUST LEVELERS AFTER MOVING THE BED.