

Item No.: EB052T-8060

Installation guide

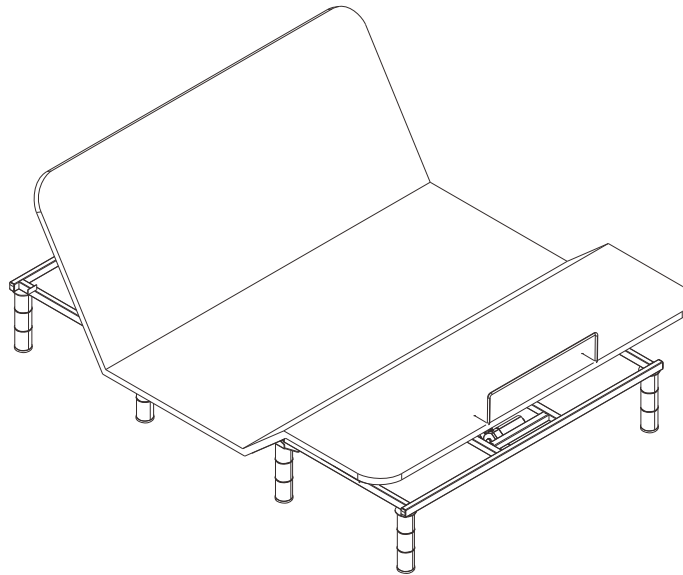

The pictures are for reference only, the actual product shall prevail.
Please read the instruction manual before installing and using the furniture.

CONTENTS

1. Instructions for use	P1
2. Installation Preparation	P2
3. Parts List	P3
4. Installation Steps	P4-P10
5. Function Description of Remote Control Buttons	P11
6. Electrical Configuration Diagram	P12
7. Troubleshooting	P13-P14
8. Important Notes	P15-P16

Instructions for use

Main Material

Main Material	Application site
Carbon steel pipes	Base frame
Plastic	Electrical enclosure
Fabric	Bed cover

Executive Standard

Q/NLG 010

Product Parameters

Product name	Iron-frame Fabric-covered Electric Bed				
Item No.	EB052T-8060				
Bed size	1490*2000mm				
Foot size	3/6/9 inches				
Back angle	0°~60°	Leg angle	0°~40°	Noise	< 60dB
Input power	AC100V~240V	Load capacity	272kg		

Installation Preparation

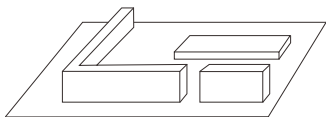

Install on carpet to prevent scratches.

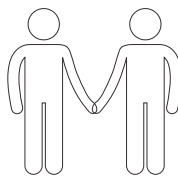

Need two or more people to cooperate together.

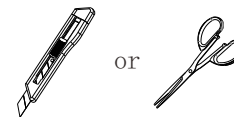

Knife or scissors. (prepared by customer)

Parts List

Unpack the case and you can see

1 Bed Frame (x3)



2 Mattress Retainer Bar (x1)





3 Accessories Box (x6)



4 Fitted Sheet (x1)

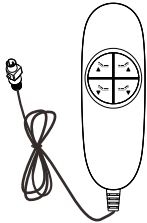
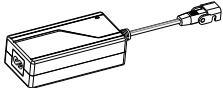
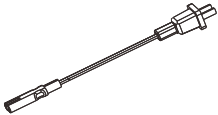
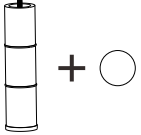
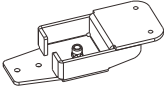

Core Accessories Package

<p>1 Wired Remote Control (x1)</p>	<p>2 Power Adaptor (x1)</p>	<p>3 AC Power Cord (x1)</p>	<p>4 Adjustable Bed Legs / Bed Leg Pad (x8)</p>
			
<p>5 Connecting Component (x4)</p>	<p>6 Screw (x16)</p>	<p>7 Allen Key(x1)</p>	
			

Installation Guide

STEP1 (Note: Do not cut the orange zip ties yet.)

- a Please open the box cover, **cut off all the white zip ties**, and take out the bed. Make sure not to puncture the cardboard box with any sharp objects.
- b Place the bed frame on a clean and flat surface (as shown)
- c Take out all the accessories from the packaging.

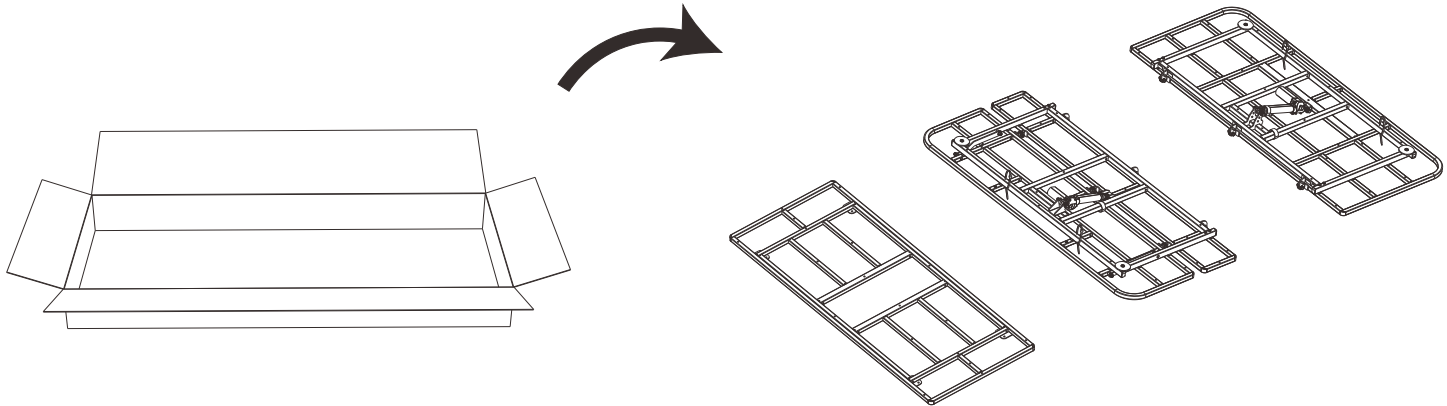

<The image is for illustrative purposes only, please refer to the actual product for accurate instructions>

STEP2

- a** Place the headboard and footboard upside down on the floor as shown in the diagram, and place the connecting component at the connecting part.
- b** Use an allen key and screws to tighten and secure the connection.

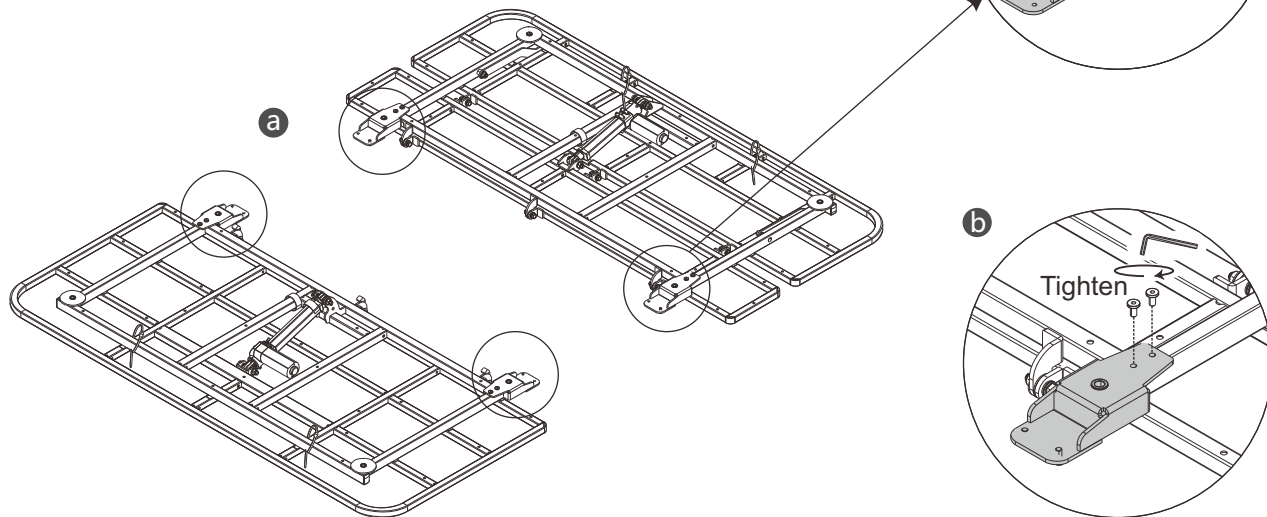

<The image is for illustrative purposes only, please refer to the actual product for accurate instructions>

STEP 3

(Friendly reminder: Depending on your desired overall bed height, you can choose to install 1 section, 2 sections, or 3 sections of bed legs. Ensure that each section of bed legs is tightened.)

- a Keep the bottom of the bed frame facing upwards and install the bed legs, then tighten them.
- b Please stick the bed feet pads on the bottom of the bed feet.

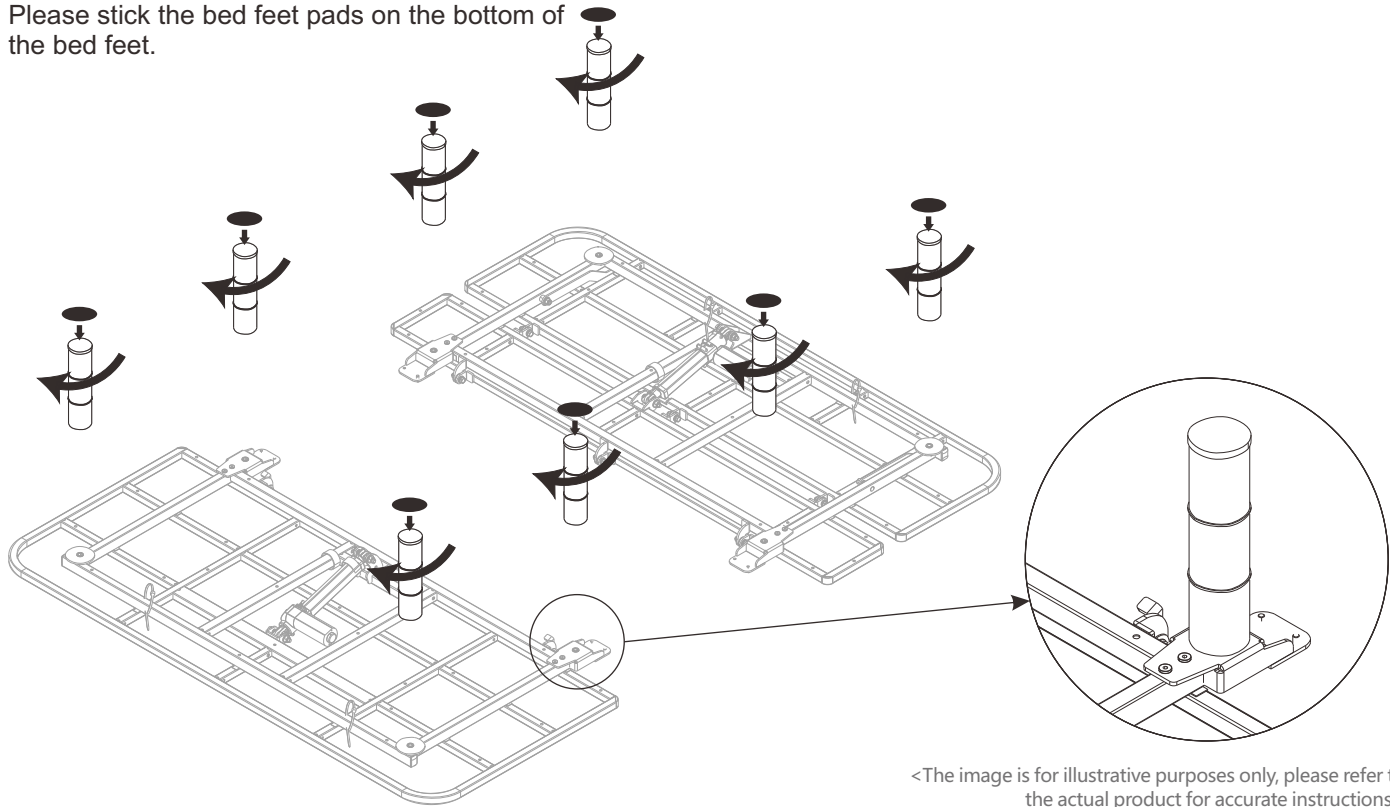

STEP4

- a** As shown, flip the assembled bed frame over and place the middle bed frame on the connectors.
- b** Align the eight screws with the corresponding holes.
- c** Respectively tighten them in place.

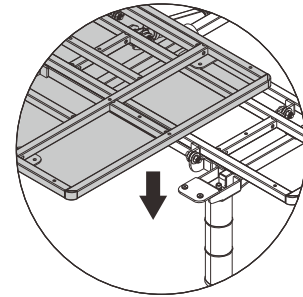
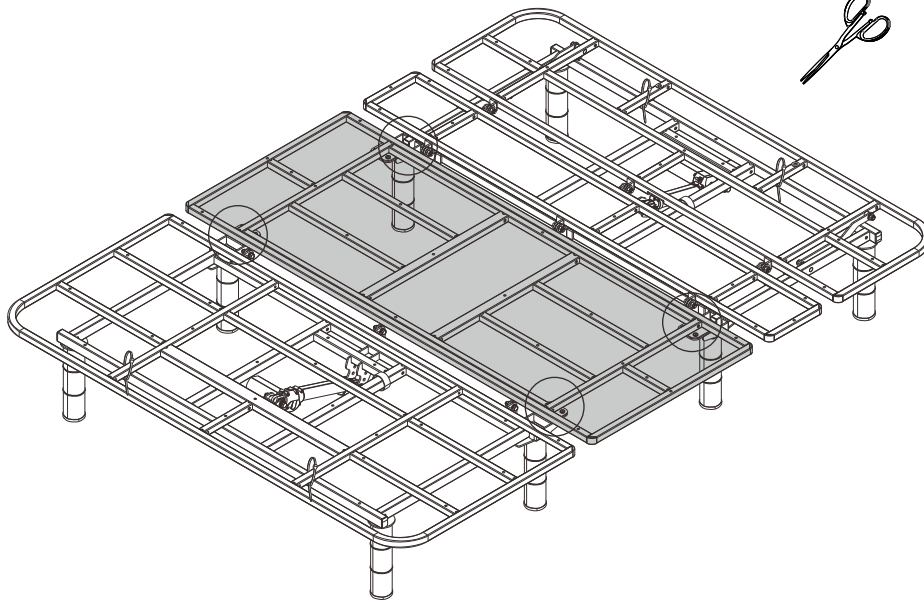

Not to fully tighten

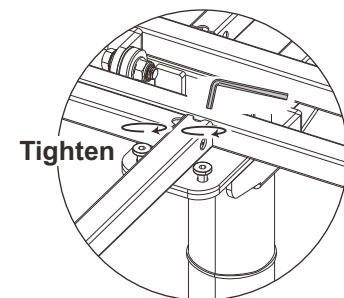
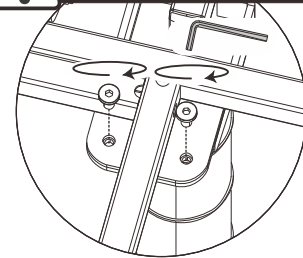

Tighten

<The image is for illustrative purposes only, please refer to the actual product for accurate instructions>

STEP 5

- a** Pass the cable A of the back motor through the Velcro of the middle bed frame and connect it to the motor wire of the leg;
- b** Connect cable B of the back motor to the adapter, and then connect the other end of the adapter to the power cord;
- c** Connect the cable C from the back motor to the remote control.

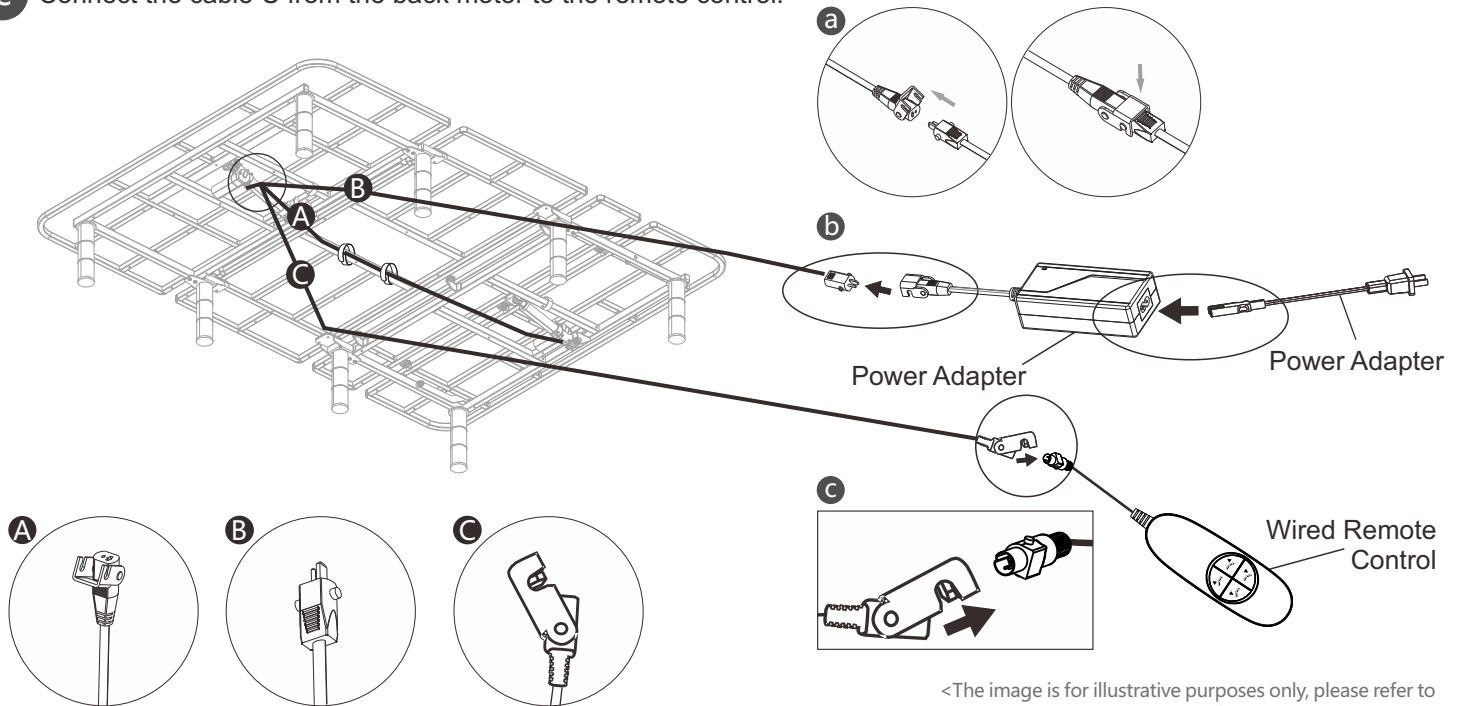

<The image is for illustrative purposes only, please refer to the actual product for accurate instructions>

STEP 6

- a After completing the cable connecting as shown in the diagram. Then, use the wired remote control to raise the backrest and legrest of the bed to the highest angle;
- b First, fit the fitted sheet onto the frame. Then, securely fasten the four straps on the head and foot of the bed to their corresponding positions as indicated in the diagram. The end of each strap with a metal buckle should be attached to the foot of the bed.

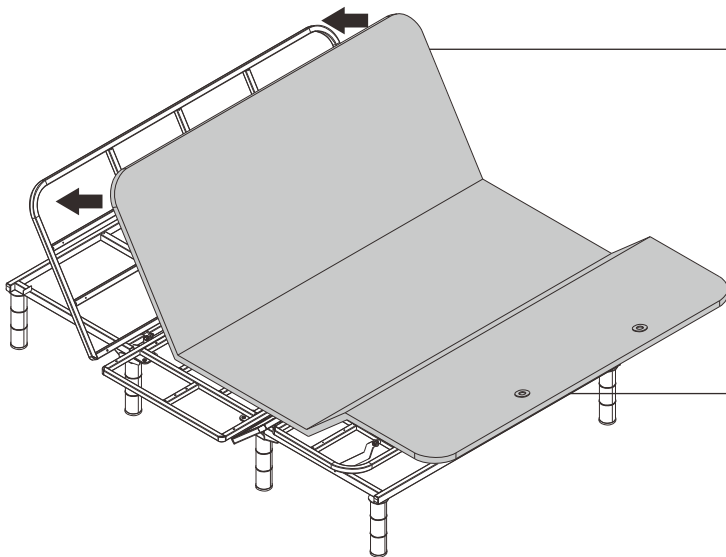

Strap Position Diagram

Note: The hook surface and loop surface of the Velcro should be aligned and attached together.

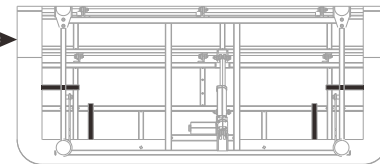
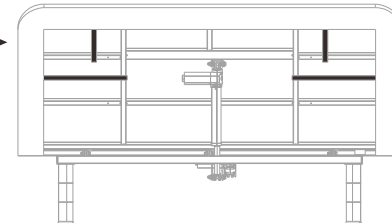

<The image is for illustrative purposes only, please refer to the actual product for accurate instructions>

STEP 7

After flattening the bed, install the bed mattress and secure the straps on both sides of the bed frame. Once done, the product can be used normally.

Friendly reminder: Avoid dragging the bed as there is a risk of bending the bed legs.



1. Two people are required to turnover the bed gently.
2. It is forbidden to have a single leg endure the weight during transportation and turnover.

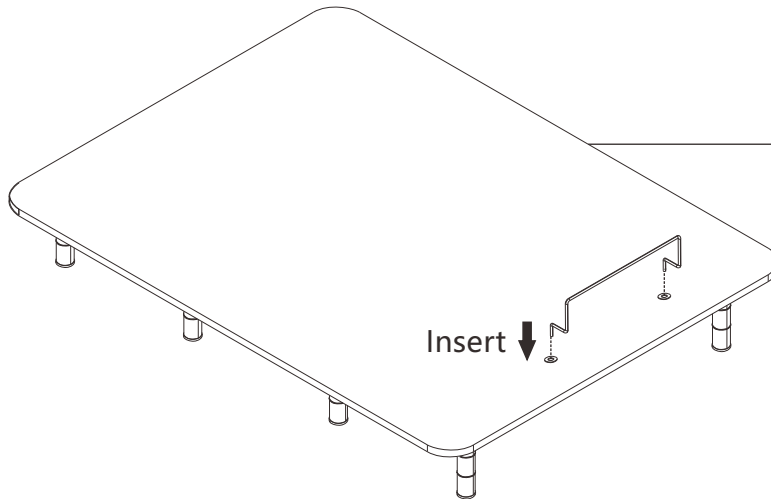

Strap Position Diagram

Note: The hook surface and loop surface of the Velcro should be aligned and attached together.

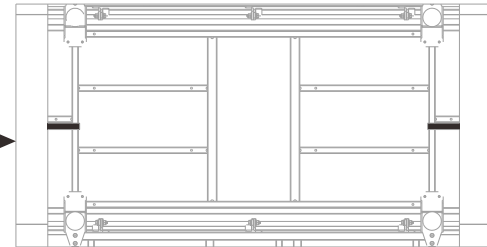

<The image is for illustrative purposes only, please refer to the actual product for accurate instructions>

Function Description of Remote Control Buttons

● Button instructions:



Do not press two keys simultaneously

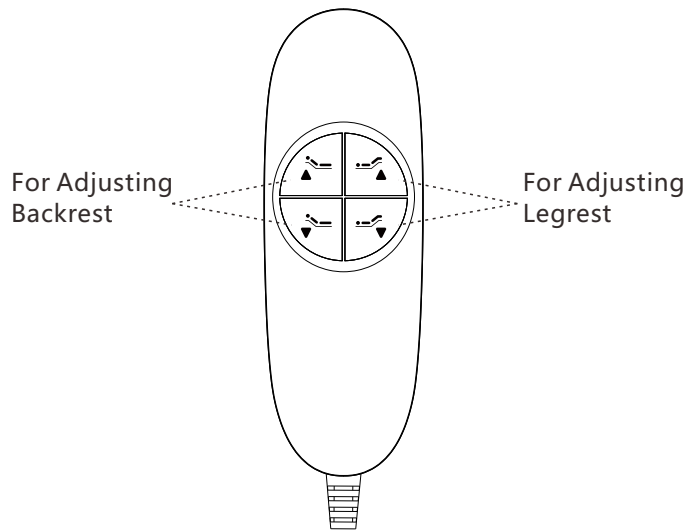

	To control the backrest bed frame
	To control the legrest bed frame

Electrical Configuration Diagram

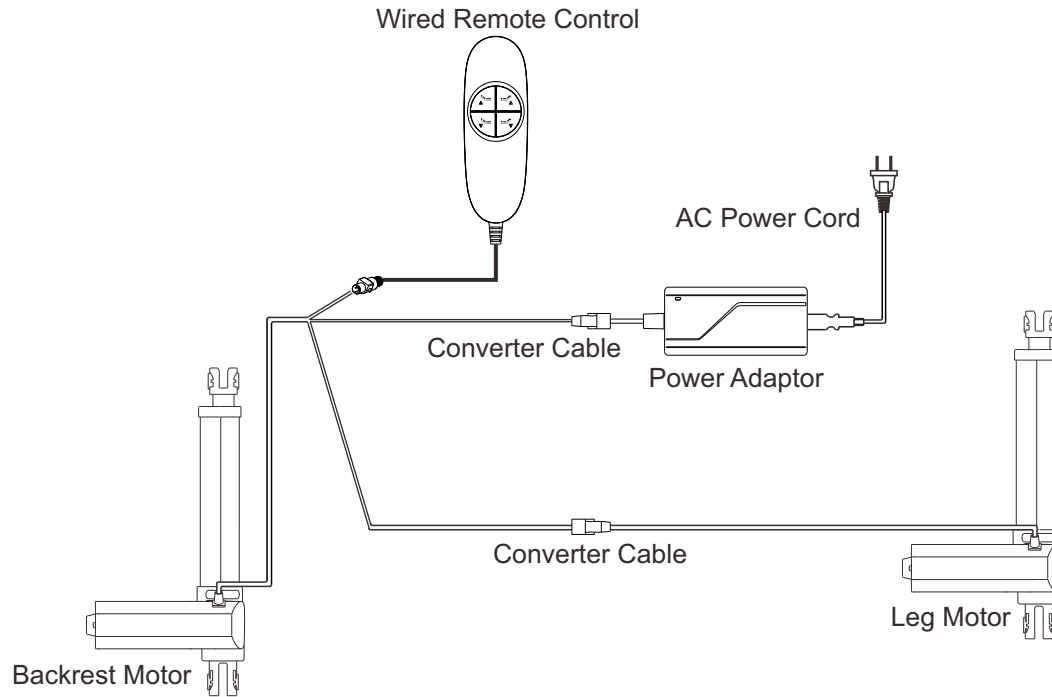

Troubleshooting

If the product malfunctions, please refer to the table below for possible problems and solutions.

Problem	Solution
The wired remote control buttons are not working.	Please check if the cable of the wired remote control is properly connected.
None of the functions of this product are available.	<ol style="list-style-type: none">1. Make sure the control box is properly connected to the motor.2. Ensure that all power cables are correctly connected.3. Check if the power cord is plugged into a functioning power source or outlet.
The adjustment is normal but it cannot return to a flat position.	<ol style="list-style-type: none">1. Remove any potential obstacles that may be affecting the bed's movement.2. Check if the head and foot sections of the bed are too close to the walls.
When raising or lowering the head portion of the bed, a clicking sound can be heard from under the bed.	It is a normal phenomenon, and it is the sound produced by the actuator motor. No action is required.
There may be a jerking sensation when this product is in motion.	<ol style="list-style-type: none">1. Clean any clutter or obstacles under and around the adjustable bed.2. Ensure that the control box is properly connected to the actuator motor.

Troubleshooting

If the product malfunctions, please refer to the table below for possible problems and solutions.

Problem	Solution
This product squeaks.	<ol style="list-style-type: none">1. Please use lubricant to lubricate the component connections, such as pins, nuts, bolts, bushings, etc.2. Ensure that the nuts are not over-tightened.3. When reinserting lubricated pins, nuts, bolts, or bushings into the adjustable bed, make sure not to over-tighten the nuts.4. Additional solution: After completing these steps, spray lubricant on the pins, nuts, bolts, bushings, or bed frame joints.

Attention

01. Before turning on the power, check whether the voltage is normal and whether it meets the power requirements of this product: AC100-240V, frequency 50/60HZ.
02. This product is only suitable for indoor use at home, please do not use it in other places. Do not use with oxygen or other flammable gases.
03. The place where this product is placed should not be too humid and not exposed to direct sunlight. It is necessary to maintain proper air circulation so as not to affect the normal use of this product.
04. Do not use liquids on this product, in case of spillage, unplug the power cord in a safe manner. Make sure this product is completely dry before using it again.
05. This product must be protected from moisture, water, sun, shock, falling, and trampling during movement or transportation. When moving, it should be handled with care to avoid damage.
06. Do not put sharp objects (keys, knives, nail clippers, etc.) and hard objects on this product to avoid damage.
07. Before using this product, please make sure that there are no people or pets under the bed.
08. The power cord needs to be extended from the bottom of the product and inserted into the socket to ensure that it will not be pressed and cause damage during operation. Keep cords away from moving parts of this product and heated surfaces.
09. The electronic components, metals, plastics, wires, etc. contained in the electrical box should be disposed of in accordance with the environmental regulations of various countries, and please do not dispose of them as conventional household waste.
10. When the product is in the lifting state, do not release all the weight on the head or end of the bed, so as not to damage the structure.
11. When the product is in a non-flat state, please do not perform strong impact sports such as jumping.
12. Non-professionals are not allowed to disassemble the electric bed structure and motor, so as not to cause irreversible damage to the electric bed.
13. This product has been equipped with a corresponding remote control when it leaves the factory, please operate and use it according to the instruction manual.
14. After the power supply is installed, use the remote control to check whether the functions are working normally.
15. Please do not open or tamper with the control box, motor, or remote control. Any modification will void the normal warranty.
16. The maximum load-bearing capacity of the product is shared on the bed, not on the head or feet of the bed alone; the damage caused by exceeding the load-bearing capacity cannot be guaranteed.
17. It is recommended to wear protective gear during installation and disassembly.
18. Before using the product, please check carefully to make sure that the product has been completely and correctly installed. Only the accessories provided by the manufacturer can be used for product installation. Please leave a sufficient safety gap when placing the product to avoid the risk of pinching.
19. Operate under the condition of understanding the relevant dangers. Children and those with physical and sensory defects and mentally unsound persons should use it under correct supervision and guidance. Children are not allowed to touch and play at will.
20. If the power cord is damaged, it must be replaced by the manufacturer or related professionals to avoid injury.
21. This product contains some small parts. If swallowed accidentally, there will be a suffocation hazard. Please keep these small parts away from children, and promptly dispose of all packaging materials that may cause suffocation hazards.
22. Before cleaning or repairing, the power plug must be unplugged.

Waste disposal



This marking indicates that this product should not be disposed with other household wastes. To prevent possible harm to the environment or human health from uncontrolled waste disposal, recycle it responsibly to promote the sustainable reuse of material resources. To return your used device, please use the return and collection systems or contact the retailer where the product was purchased. They can take this product for environmental safe recycling.

