

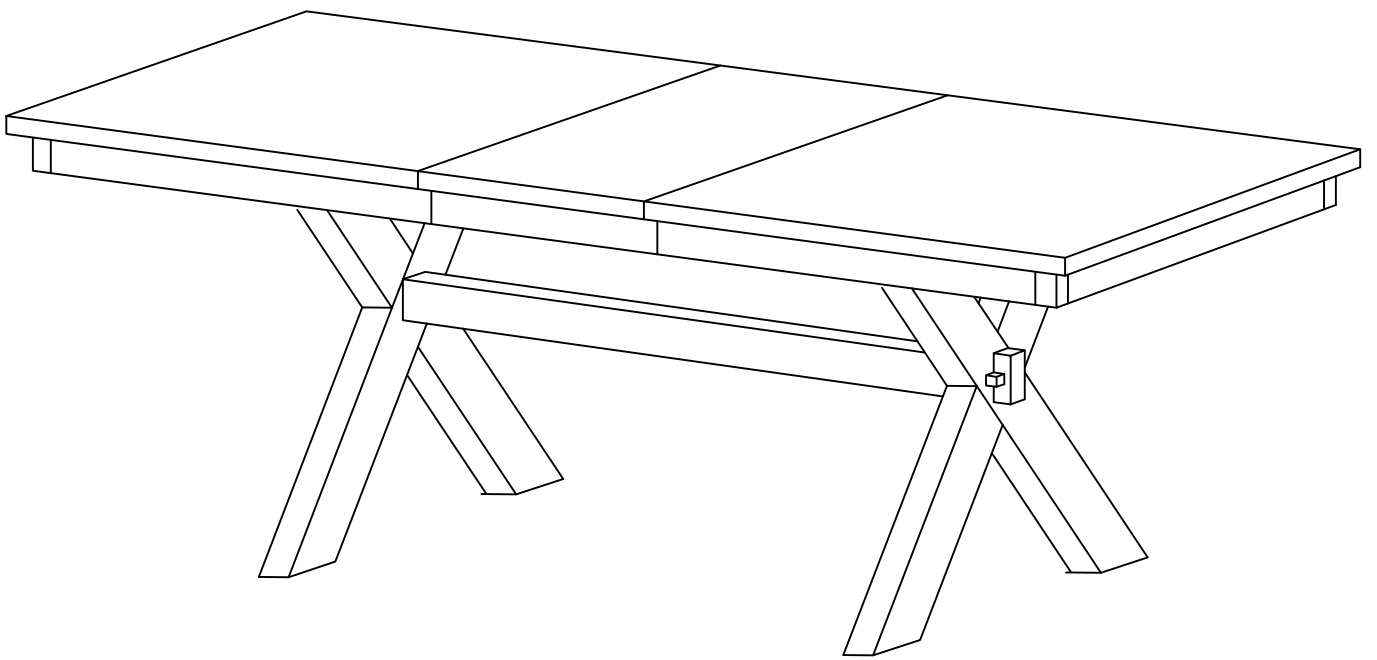

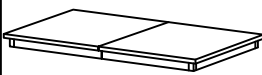

Rectangular Dining Table

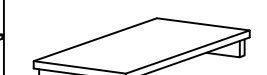



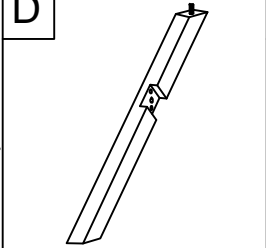
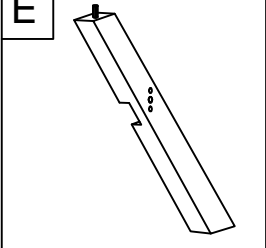

PART LIST

				
<p>Table Top 1 PC</p>	<p>Table Leaf 1 PC</p>	<p>Leg Support 1 PC</p>	<p>Left Leg 2 PCS</p>	<p>Right Leg 2 PCS</p>

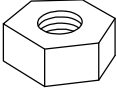
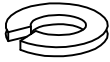
<p>Support Rail 2 PCS</p>

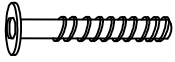
HARDWARE LIST

 <p>5/16"</p>	 <p>5/16"</p>	 <p>5/16"x19"</p>	 <p>12.8mm</p>	 <p>M8 x 60mm</p>
<p>Hex Nut 4 PCS (Extra 1)</p>	<p>Spring Washer 8 PCS (Extra 1)</p>	<p>Flat Washer 4 PCS (Extra 1)</p>	<p>Wrench 1 PC</p>	<p>Bolt 4 PCS (Extra 1)</p>

 <p>M5</p>
<p>Allen Wrench 1 PC</p>

ADDITIONAL TOOLS (Not Provided)

Note: It is not recommended to use power tools during assembly.

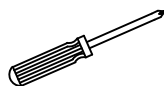

Phillips Head Screwdriver

Step 1 . Lay table top (part A) upside down on a soft surface, such as carpet. Please remove wood connector using phillips head screwdriver before installation. (See Figure 1). Pull table top (part A) and take out table leaf (part B). (See Figure 2).

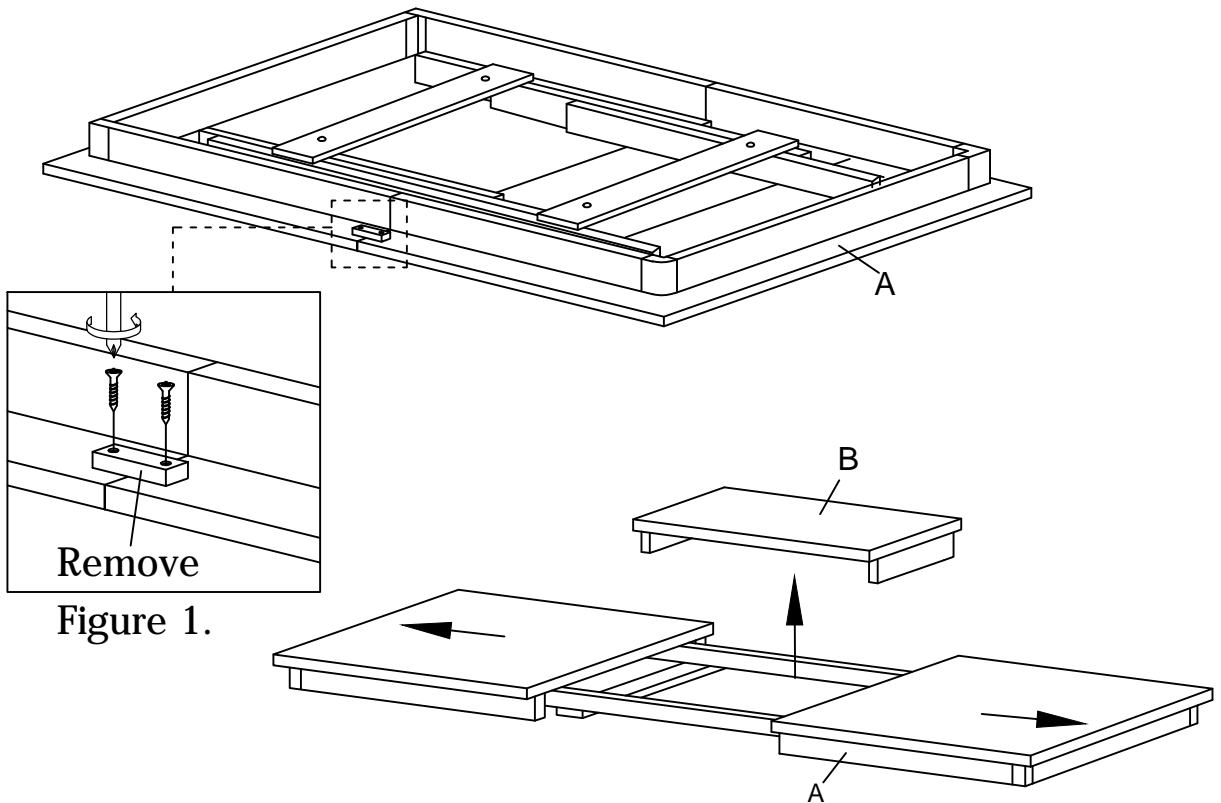
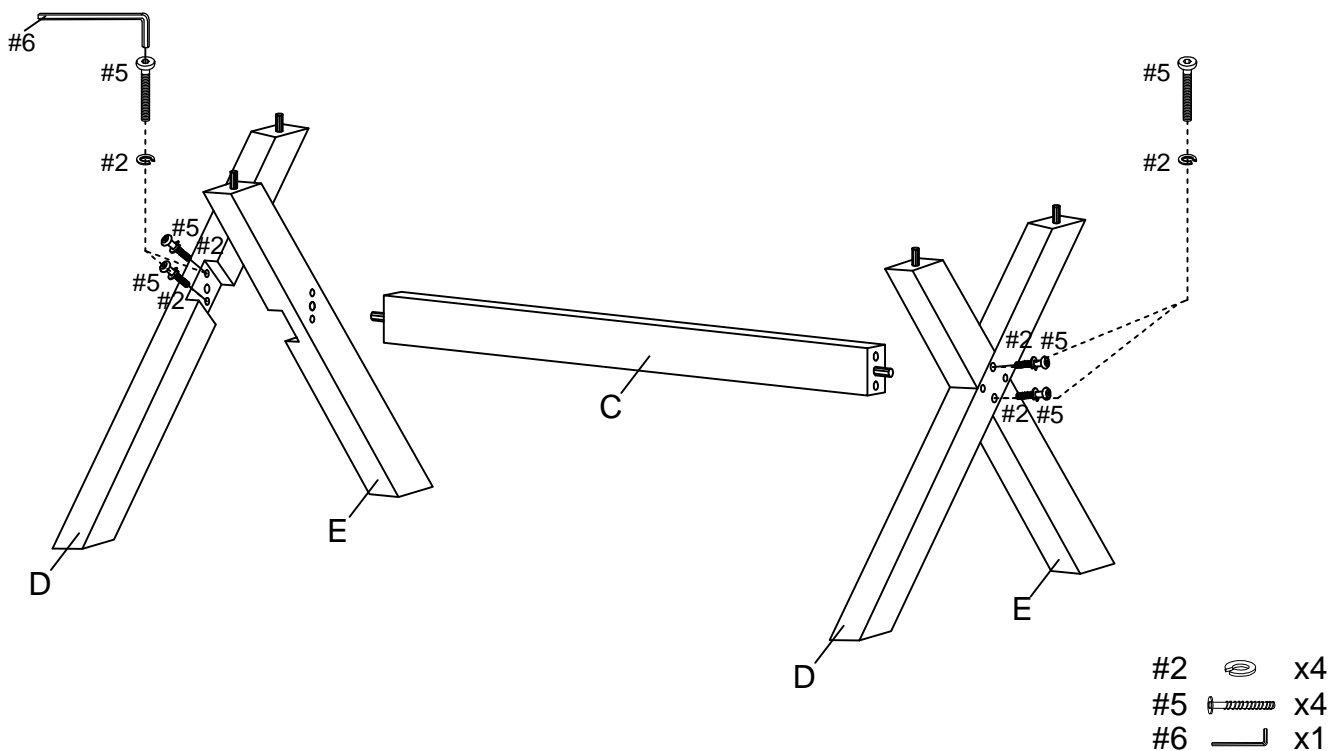

Figure 2.

Step 2 . Attach legs (parts D & E) to leg support (part C) using spring washers (part #2), bolts (part #5) and allen wrench (part #6).

NOTE: Please do not fully tighten bolts until unit is fully assembled.



Step 3 . Attach support rails (part F) to assembled unit (parts D & E). Open table top (part A). Attach table top (part A) to assembled unit (parts D & E) using hex nuts (part #1), spring washers (part #2), flat washers (part #3) and wrench (part #4).

NOTE: Please fully tighten all bolts at this time.

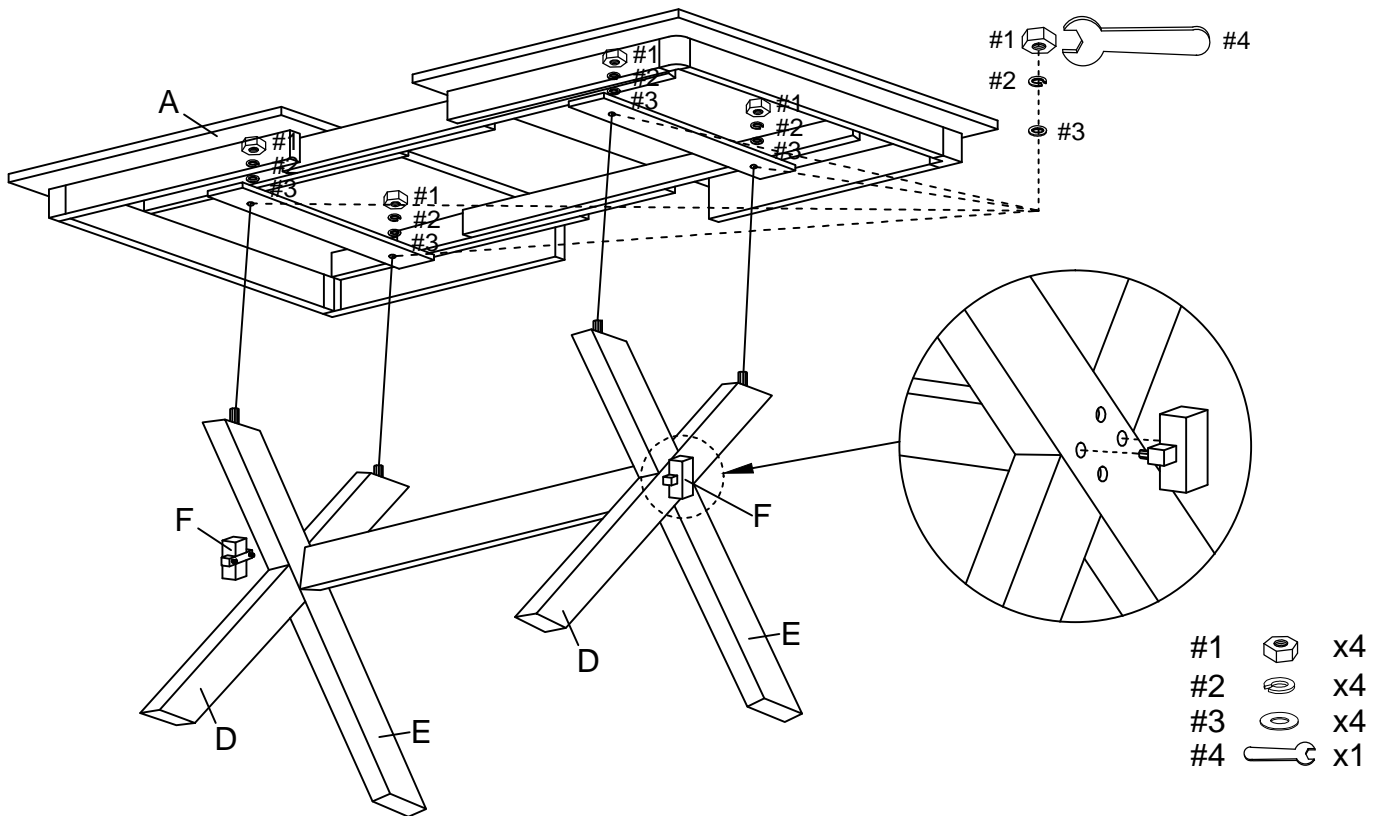

Step 4 . Place table leaf (part B) in position and push table top (part A) from both ends to close.

