

**BELLA VIEW DOLLHOUSE**  
**MAISON DE POUPÉE BELLE VUE**  
**CASA DE MUÑECAS BELLA VISTA**  
**BELLA AUSSICHT PUPPENHAUS**  
**CASA DELLE BAMBOLE BELLA VISTA**

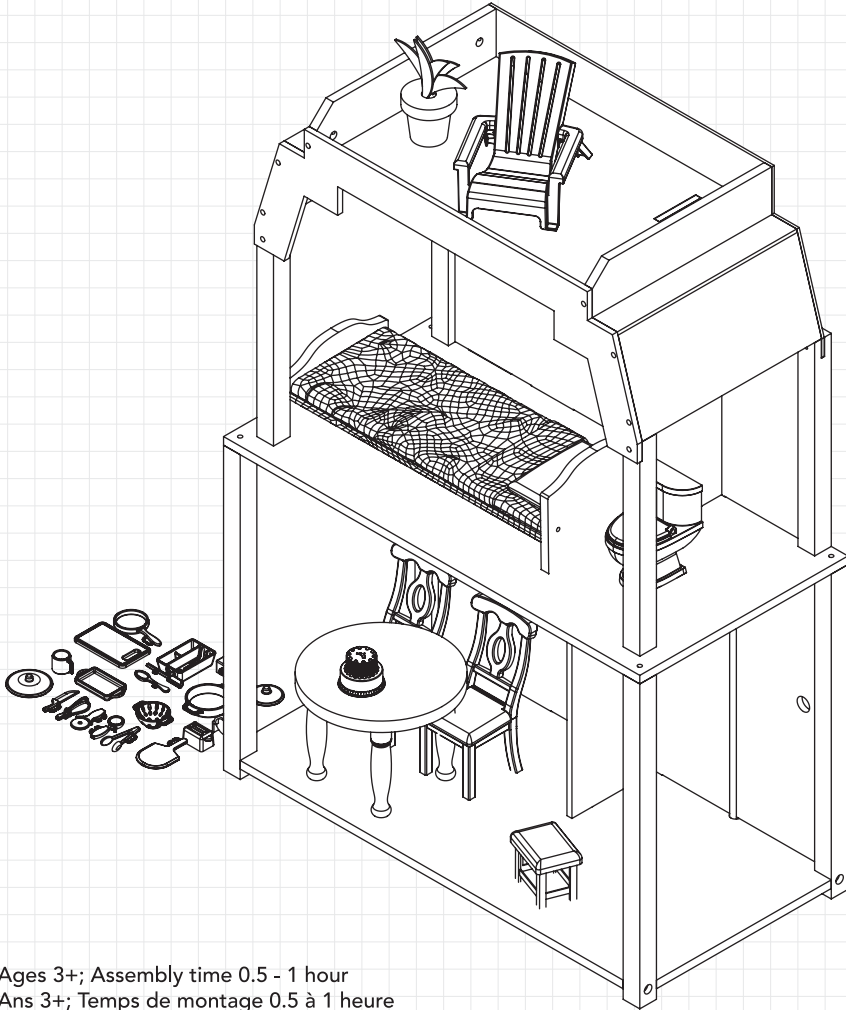

**WARNING:**  
**CHOKING HAZARD - Small parts.**  
Not for children under 3 years.

**ATTENTION :**  
**RISQUE DE SUFFOCATION -**  
**Petites pièces - ne convient pas**  
aux enfants de moins de 3 ans.

**ADVERTENCIA:**  
**PELIGRO DE ASFIXIA - Incluye**  
**piezas pequeñas. No apto para**  
niños menores de 3 años.

Ages 3+; Assembly time 0.5 - 1 hour  
Ans 3+; Temps de montage 0.5 à 1 heure  
Edades 3+; Tiempo de montaje de 0.5 a 1 hora  
Alter: 3+; Aufbauzeit 0.5-1 Stunden  
Età: 3+; Tempo di montaggio 0.5 - 1 ORE

**BATCH CODE / CODE DE LOT / CÓDIGO DE LOTE /**  
**CHARGENUMMER / NUMERO DEL LOTTO**

**FOR 24/7 ONLINE PARTS REPLACEMENT / POUR LE**  
**REPLACEMENT 24/7 DES PIÈCES EN LIGNE / PARA SOLICITUDES**  
**ONLINE DE PIEZAS DE REPUESTO DE MANERA ININTERRUMPIDA /**  
**ONLINE-ERSATZTEILE RUND UM DIE UHR / PER LA SOSTITUZIONE**  
**DELLE PARTI ONLINE 24 ORE SU 24, 7 GIORNI SU 7**

[parts.kidkraft.com](http://parts.kidkraft.com)

KidKraft, Inc.  
4630 Olin Road  
Dallas, Texas 75244  
USA

[customerservice@kidkraft.com](mailto:customerservice@kidkraft.com)

1.800.933.0771  
972.385.0100

[parts.kidkraft.eu](http://parts.kidkraft.eu)

KidKraft Netherlands BV  
Barbara Strozziilaan 101-201, 1083 HN  
Amsterdam, The Netherlands

[europecustomerservice@kidkraft.com](mailto:europecustomerservice@kidkraft.com)

We do our very best to ensure accuracy in every order, but occasionally we miss something. That's why our warranty covers every single part of your new product for 90 days after purchase.



Nous faisons de notre mieux pour assurer l'exactitude dans chaque commande, mais parfois nous manquons quelque chose. C'est pourquoi notre garantie couvre chaque partie de votre nouveau produit pendant 90 jours après l'achat.

Hacemos nuestro mejor esfuerzo para asegurar la precisión en cada orden, pero a veces se nos olvida algo. Por este motivo, nuestra garantía cubre cada parte de su nuevo producto por los próximos 90 días después de su compra.

Wir geben unser Bestes, bei jeder Bestellung sicherzustellen, dass höchste Sorgfalt geboten wird, aber vereinzelt kann es vorkommen, dass wir etwas übersehen. Aus diesem Grund deckt unsere Garantie jedes einzelne Teil Ihres neuen Produkts für die Dauer von 90 Tagen nach Erwerb ab.

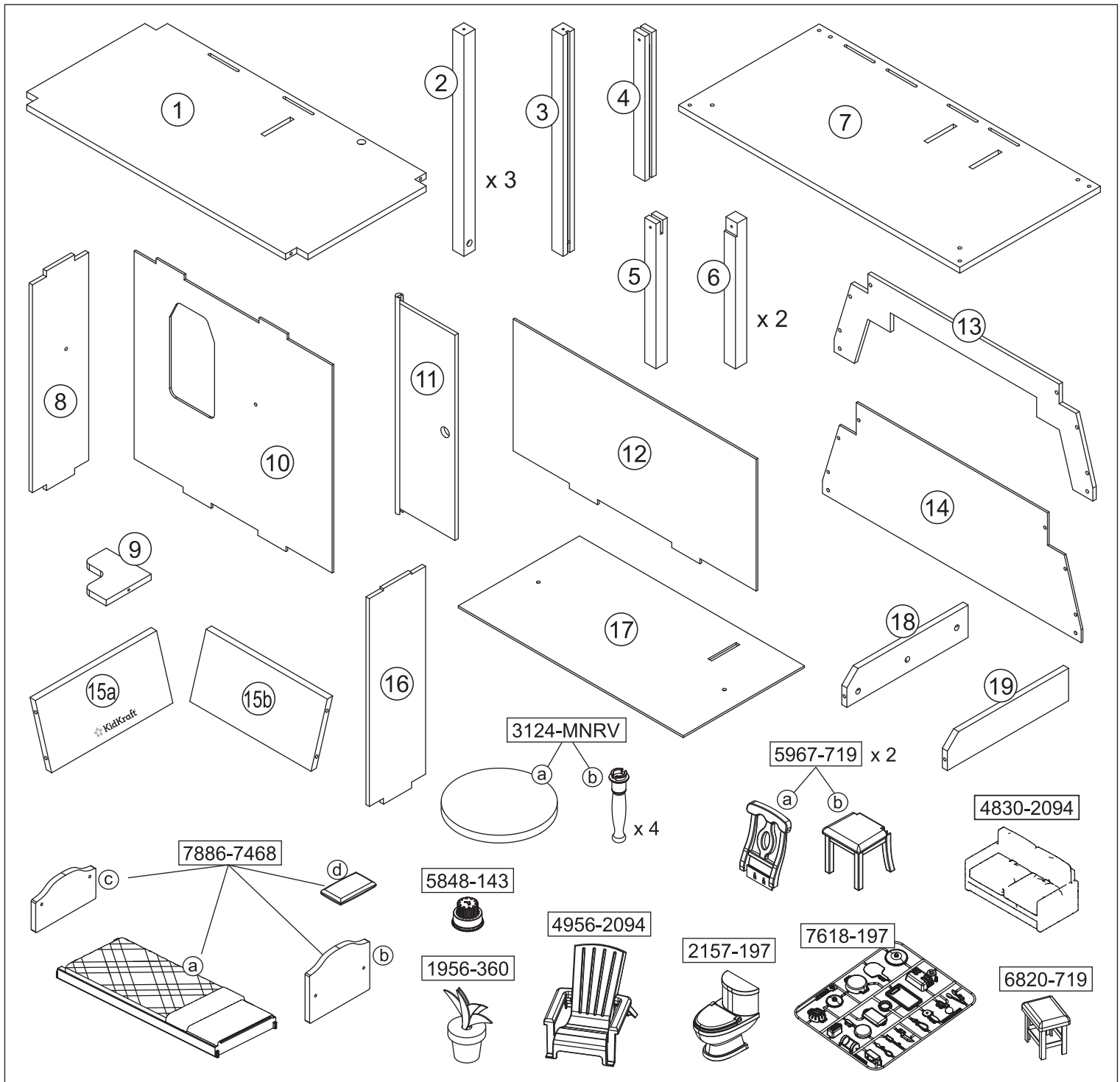
Facciamo del nostro meglio per garantire la precisione in ogni ordine, ma ogni tanto qualcosa può sfuggire. Ecco perché la nostra garanzia copre ogni singola parte del nuovo prodotto per 90 giorni dopo l'acquisto.

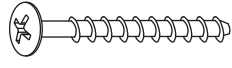
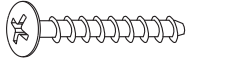

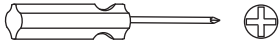
A	x 26	B	x 2	C	x 4	D	x 4
 <p><b>35 mm</b></p>	 <p><b>25 mm</b></p>	 <p><b>15 mm</b></p>	 <p><b>20 mm</b></p>	<p><b>Tool required:</b>  <b>Outils requis :</b>  <b>Herramientas necesarias:</b>  <b>Benötigtes Werkzeug:</b>  <b>Attrezzi necessari:</b></p>  <p><b>Phillips® screwdriver</b>  <b>Tournevis Phillips®</b>  <b>Destornillador Phillips®</b>  <b>Kreuzschraubenzieher</b>  <b>Cacciavite Phillips®</b></p>			

**Parts and Hardware**  
**Pièces et matériel**  
**Partes y Piezas Para Instalación**  
**Teile und Befestigungsmaterial**  
**Parti e componenti meccanici**

**All hardware dimensions are approximate.**  
**Toutes les dimensions du matériel**  
**sont approximatives.**  
**Todas las dimensiones de las herramientas**  
**son aproximaciones.**



parts.kidkraft.com

customerservice@kidkraft.com  
 1.800.933.0771  
 972.385.0100

1

Note the countersink hole  
 Notez le trou de fraisage  
 Tenga en cuenta el orificio del fregadero de la encimera  
 Senkbohrung beachten  
 Prestare attenzione alla svasatura del foro

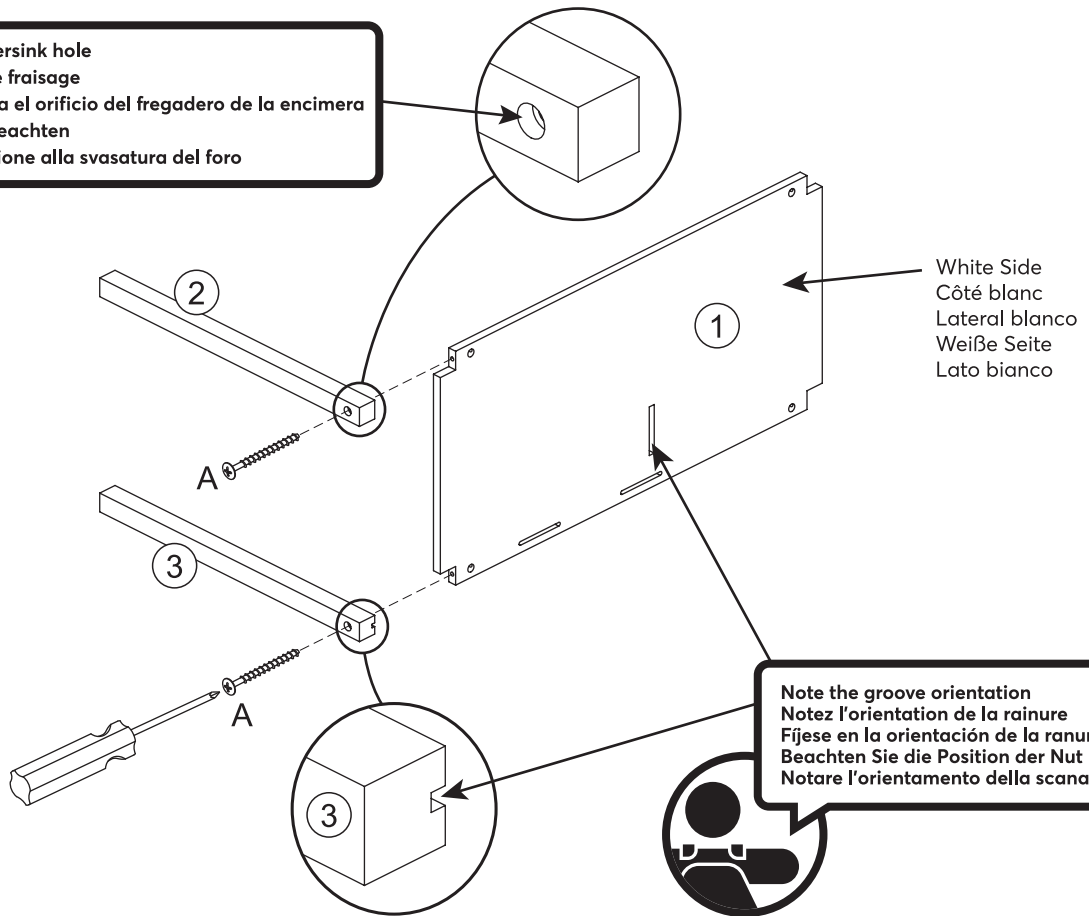

Note the groove orientation  
 Notez l'orientation de la rainure  
 Fijese en la orientación de la ranura  
 Beachten Sie die Position der Nut  
 Notare l'orientamento della scanalatura



2

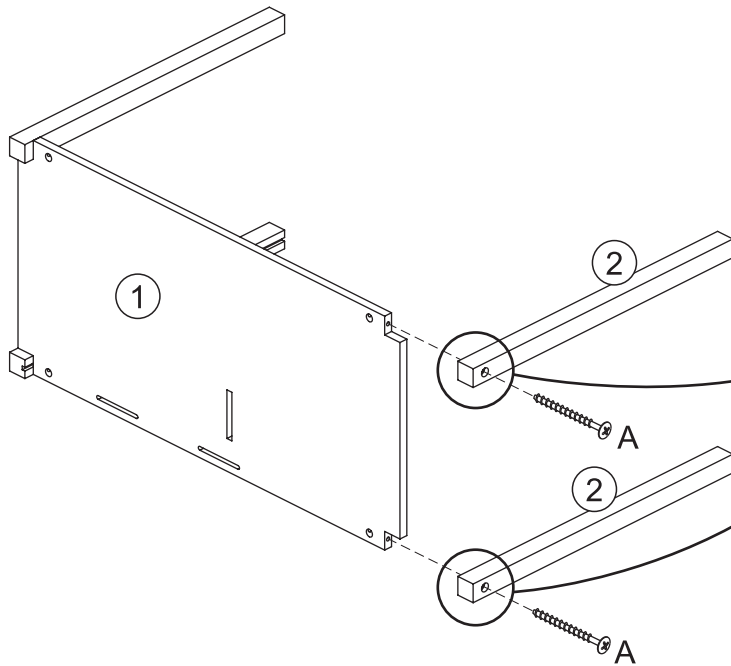

Note the countersink hole  
 Notez le trou de fraisage  
 Tenga en cuenta el orificio del fregadero de la encimera  
 Senkbohrung beachten  
 Prestare attenzione alla svasatura del foro



3

Note hole orientation  
 Faites attention à l'orientation des trous  
 Tenga en cuenta la orientación de los orificios  
 Ausrichtung der Bohrungen beachten  
 Prestare attenzione all'orientamento dei fori

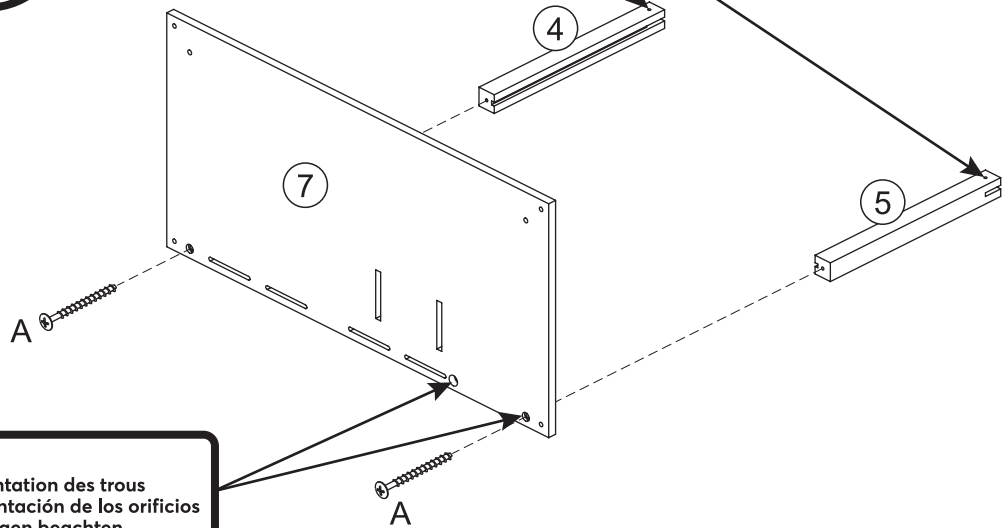

Note hole orientation  
 Faites attention à l'orientation des trous  
 Tenga en cuenta la orientación de los orificios  
 Ausrichtung der Bohrungen beachten  
 Prestare attenzione all'orientamento dei fori



4

Note notch orientation  
 Notez l'orientation de l'encoche  
 Fijate en la orientación de la muesca  
 Ausrichtung der Kerbe beachten  
 Prestare attenzione all'orientamento della scanalatura

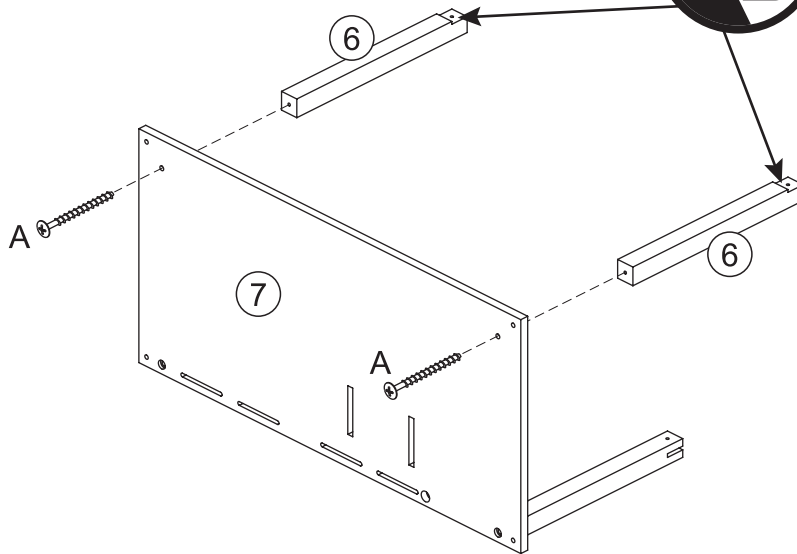

5

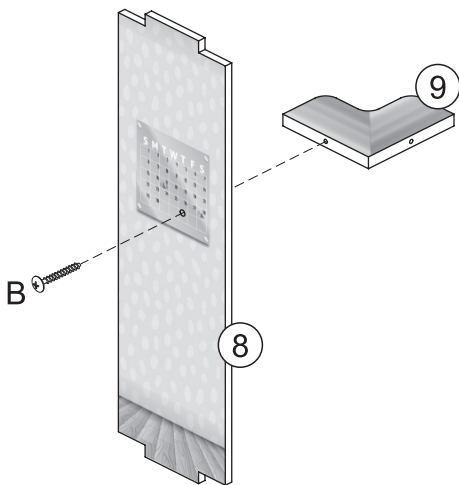

6

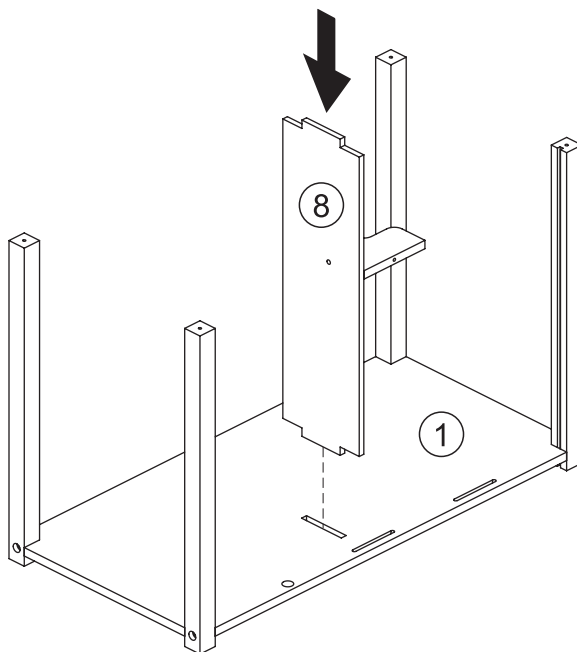

7

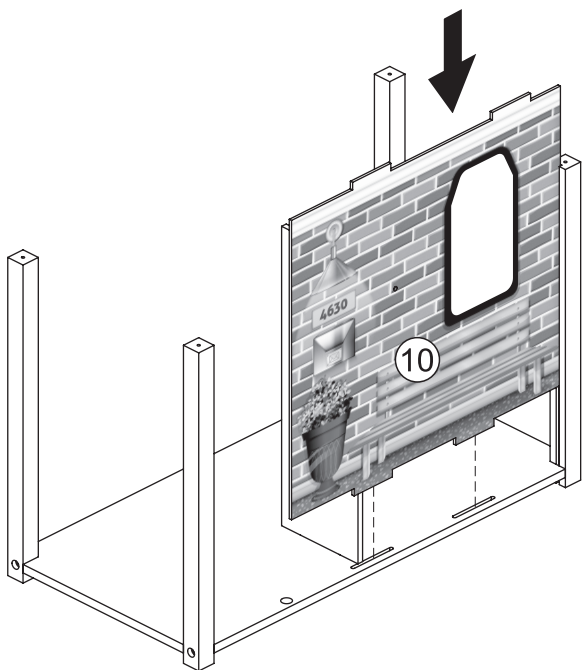

8

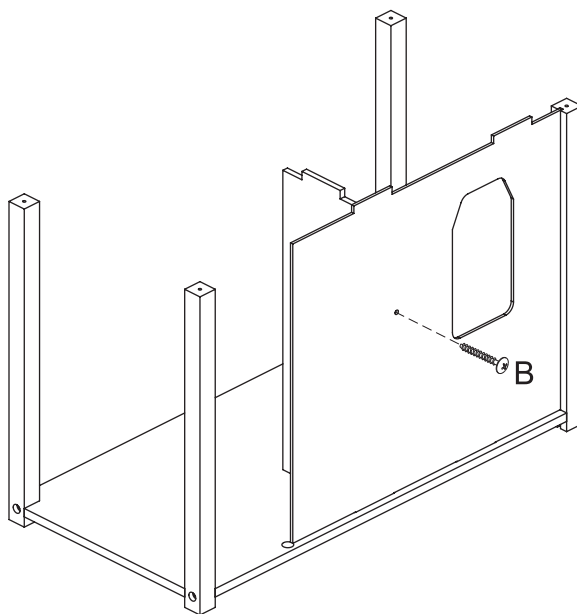

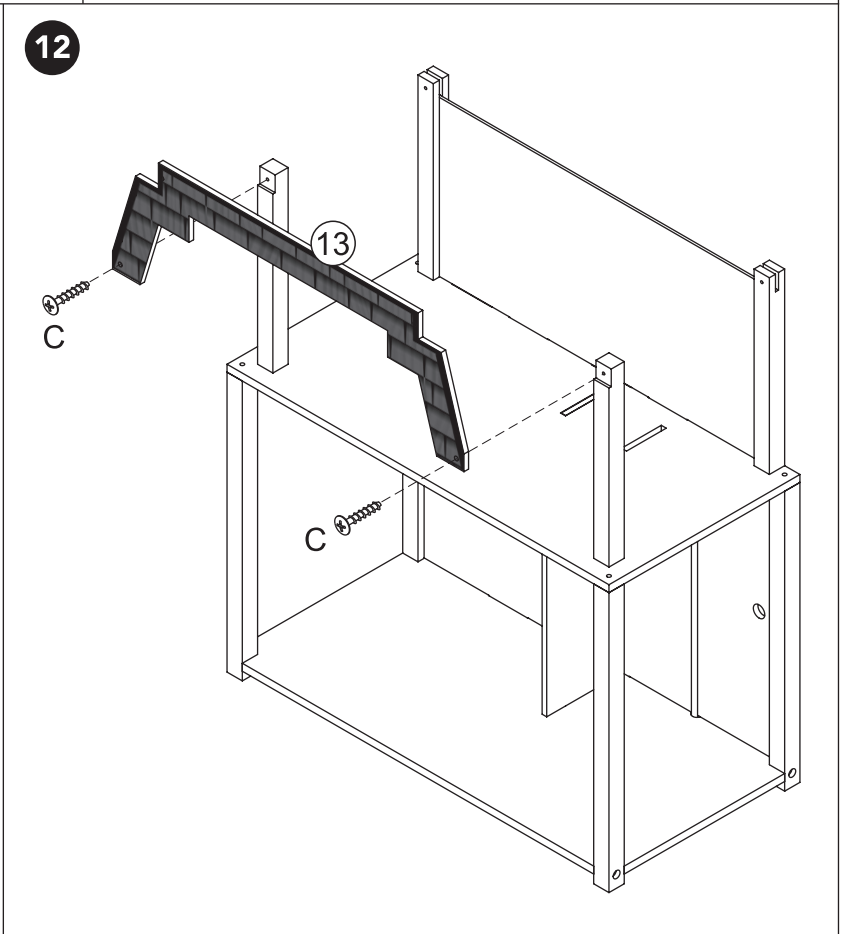
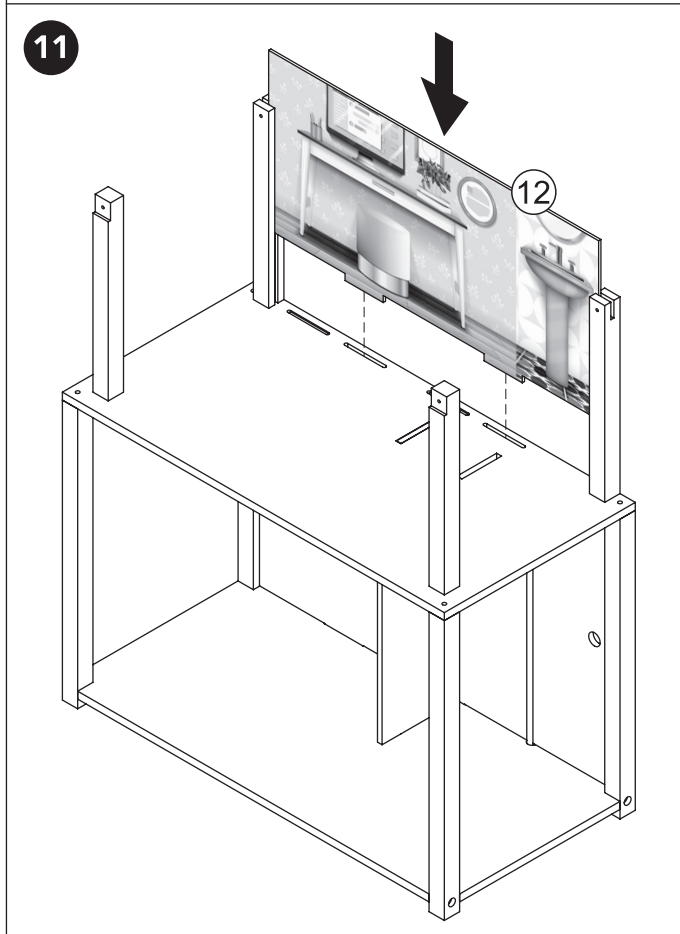
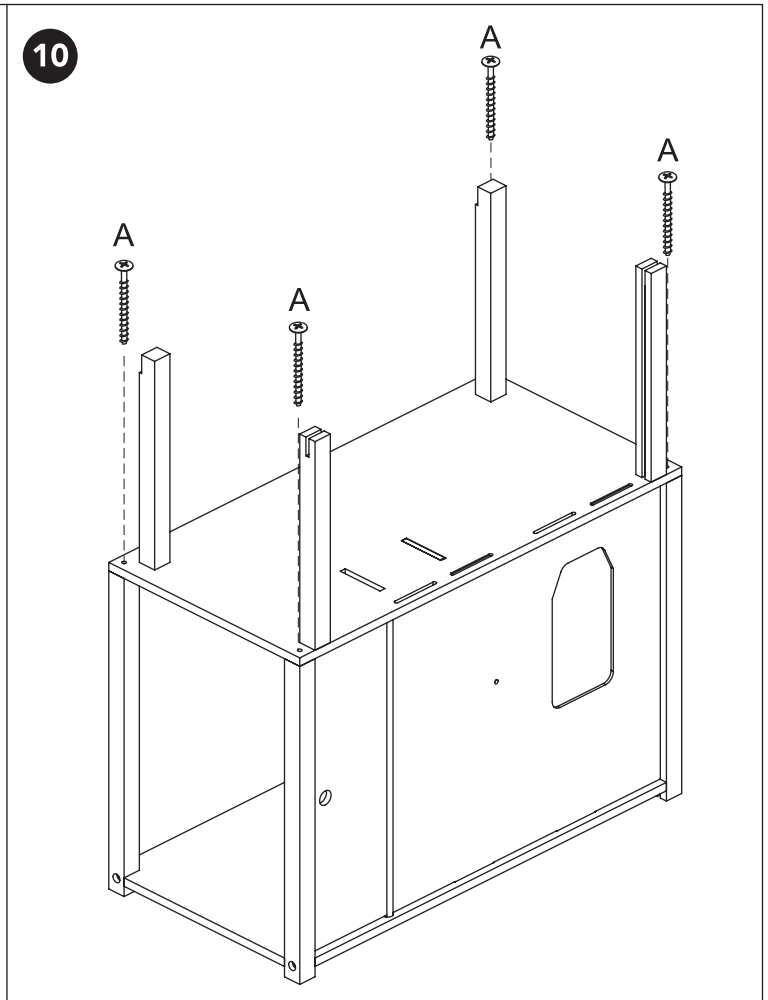
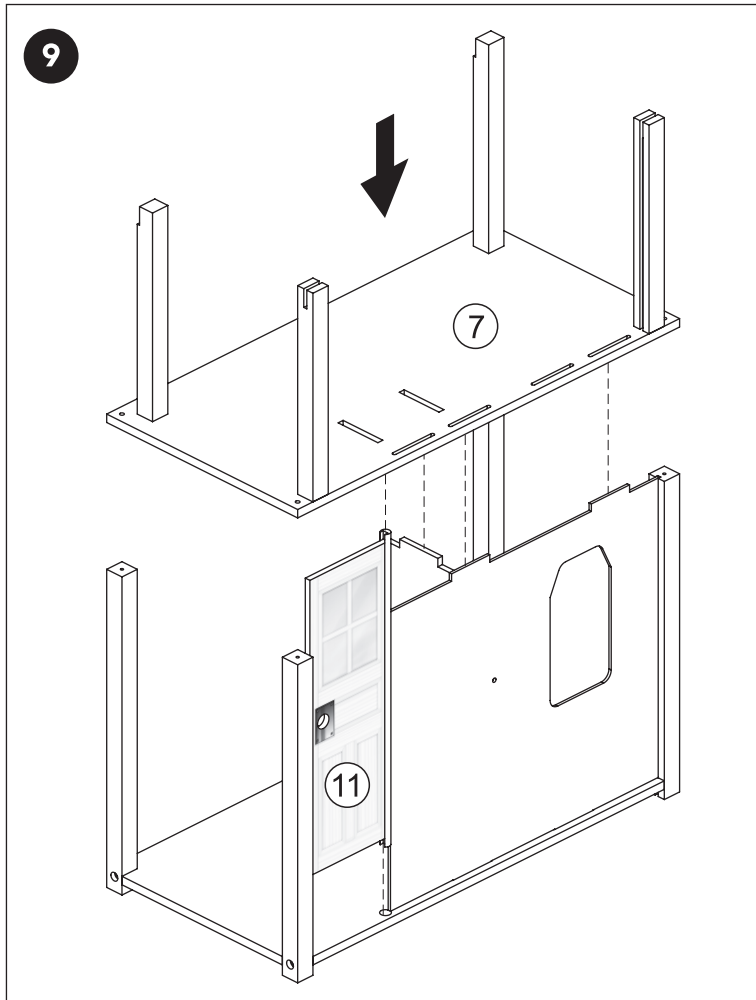

13

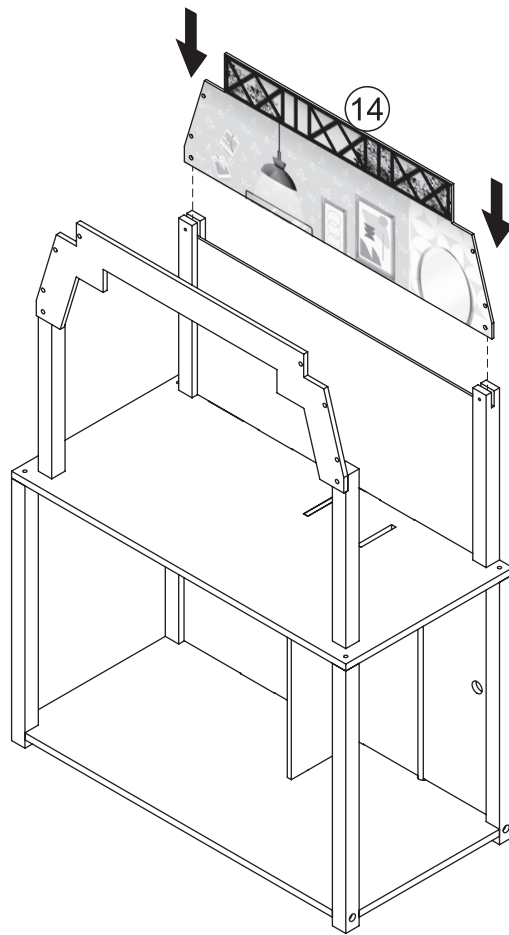

14

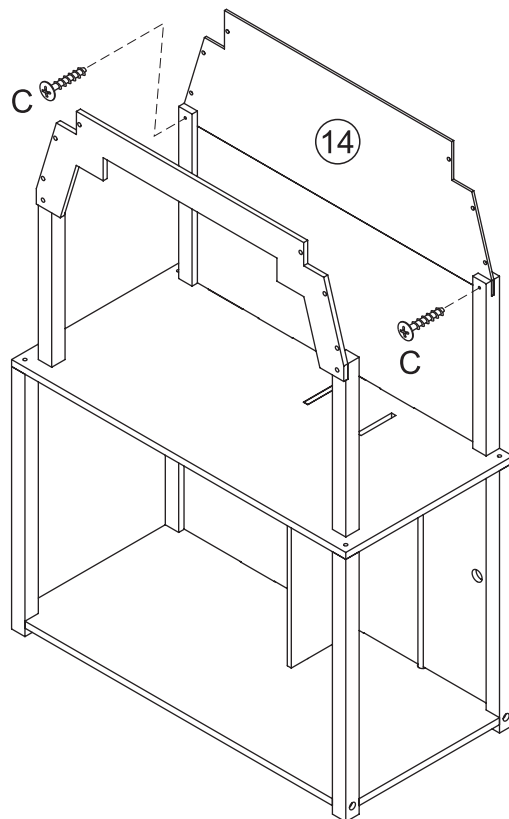

15

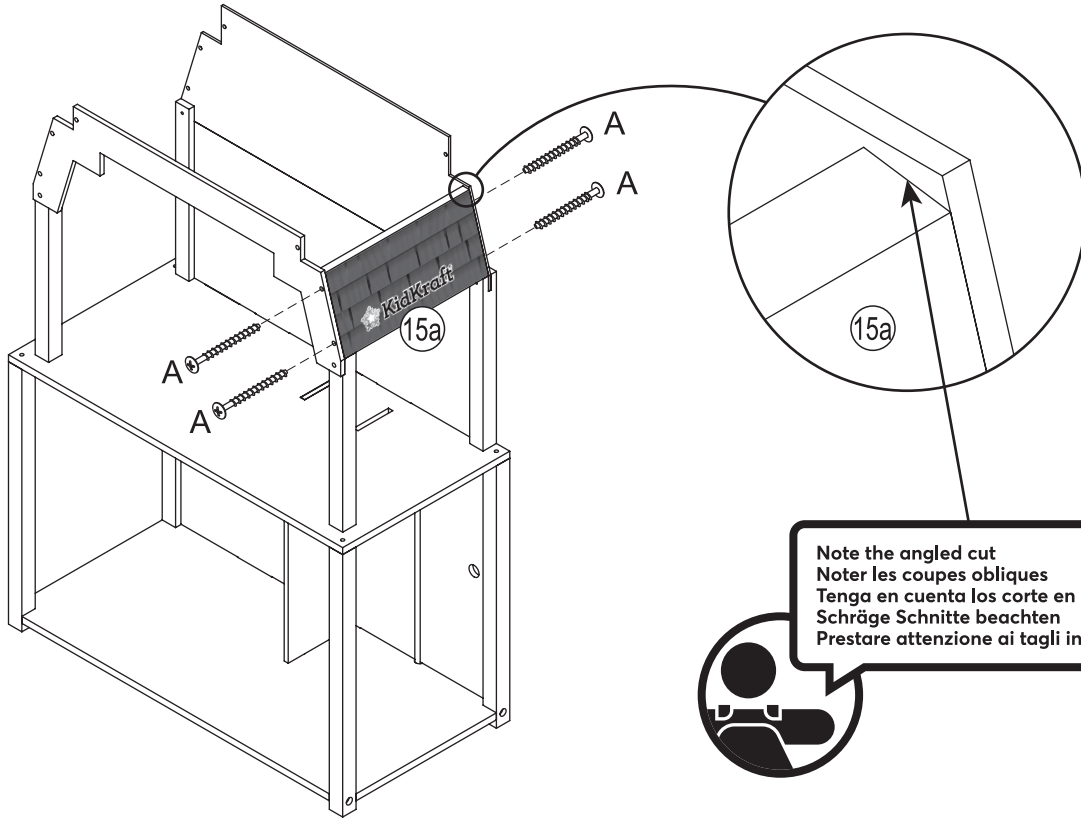

Note the angled cut  
 Noter les coupes obliques  
 Tenga en cuenta los corte en ángulo  
 Schräge Schnitte beachten  
 Prestare attenzione ai tagli inclinati



16

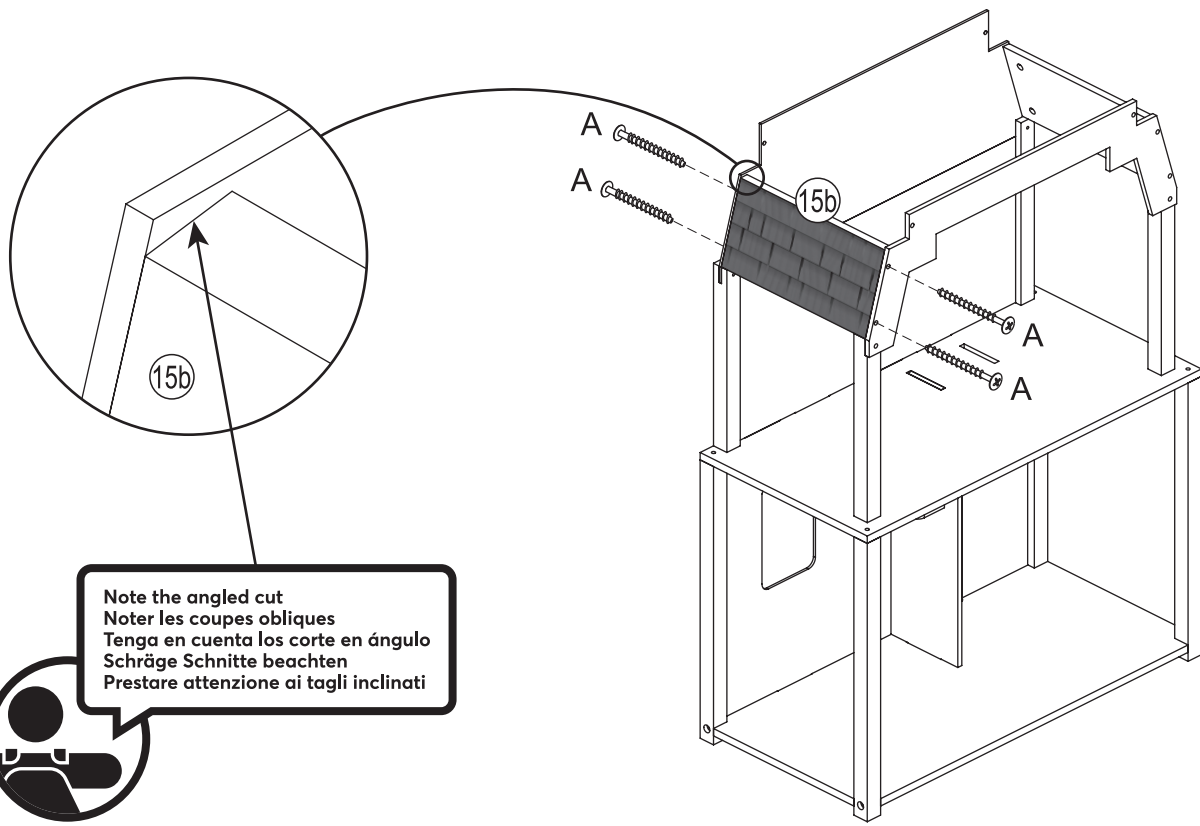

Note the angled cut  
 Noter les coupes obliques  
 Tenga en cuenta los corte en ángulo  
 Schräge Schnitte beachten  
 Prestare attenzione ai tagli inclinati



17

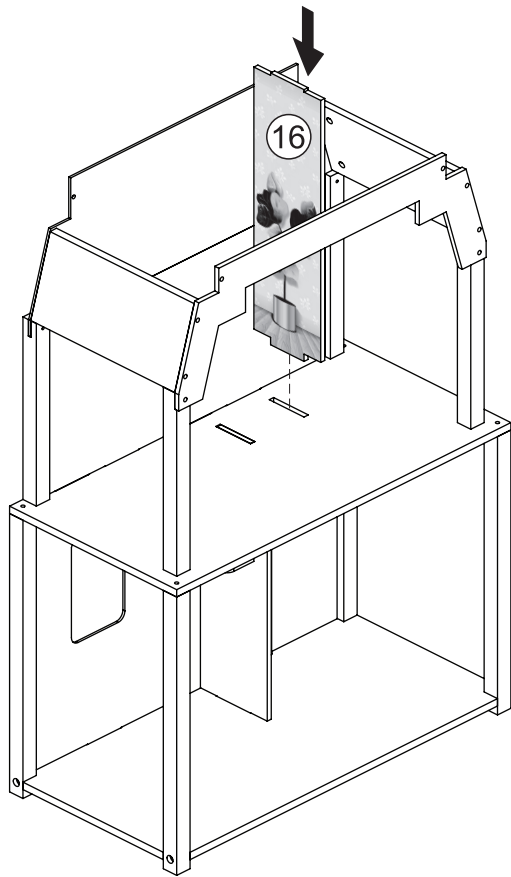

18

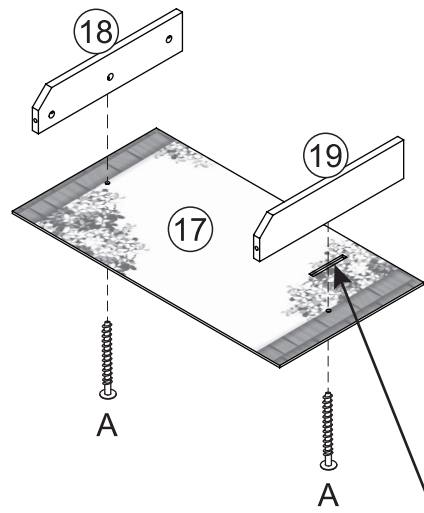

Note notch orientation  
 Notez l'orientation de l'encoche  
 Fijate en la orientación de la muesca  
 Ausrichtung der Kerbe beachten  
 Prestare attenzione all'orientamento della scanalatura



19

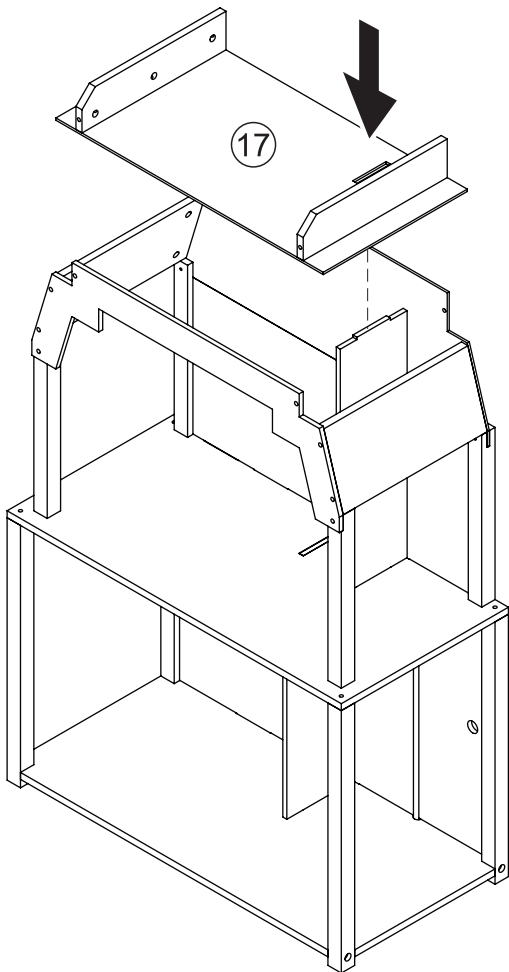

20

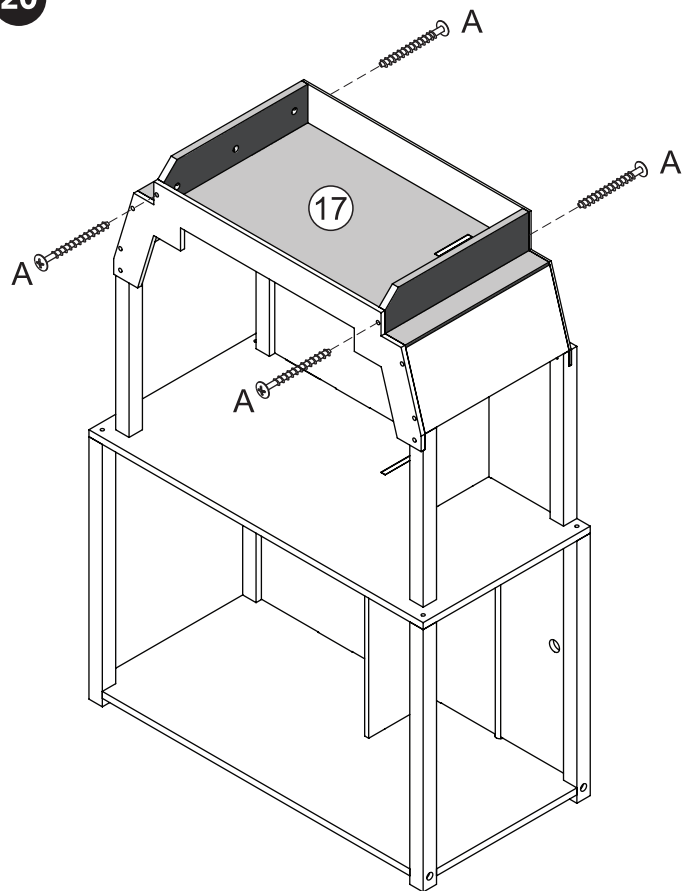

21

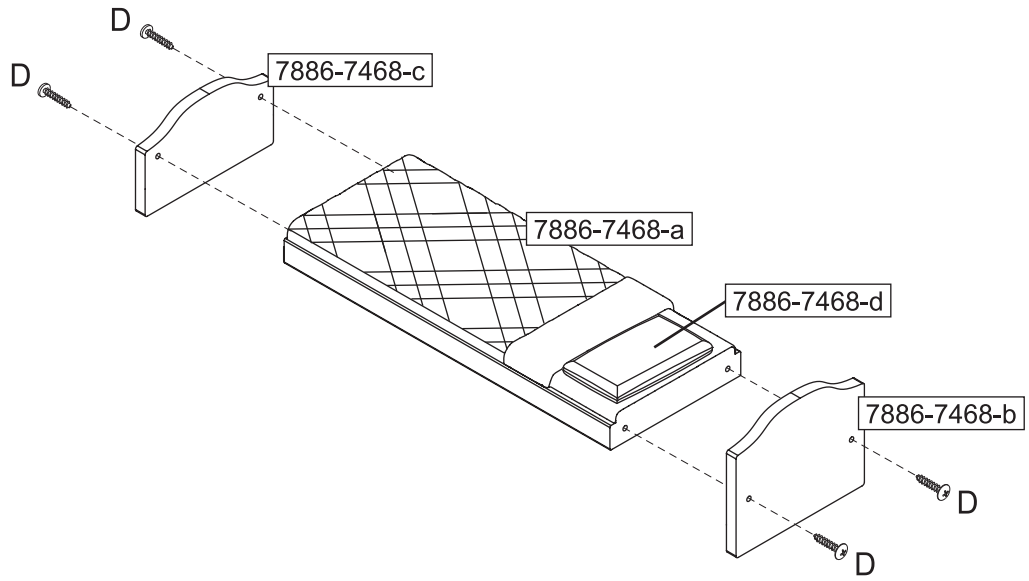

22 x 2

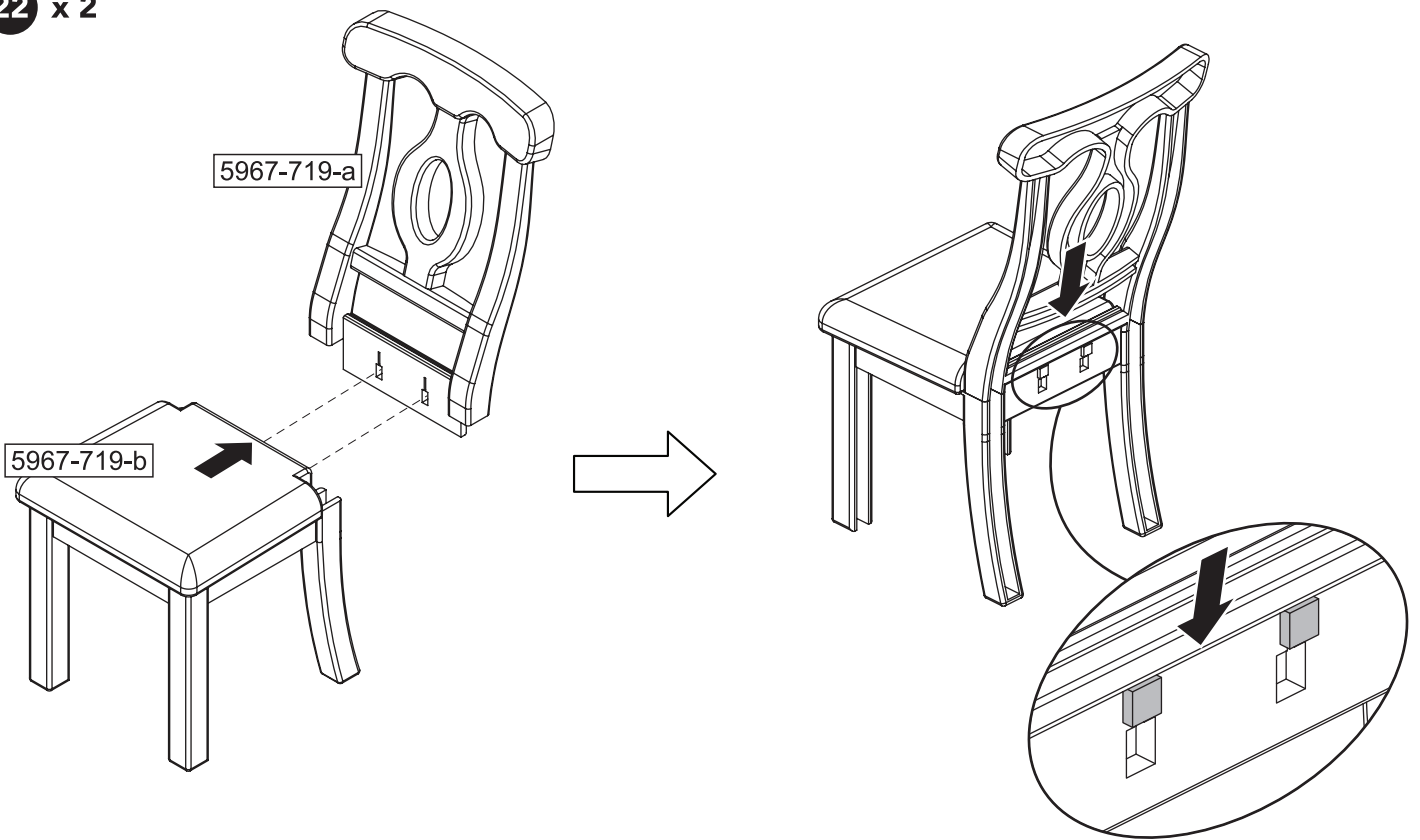

23

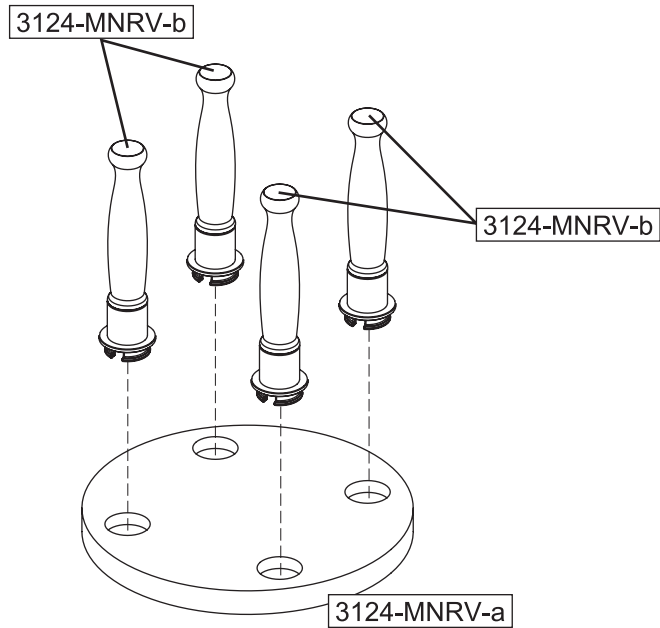

24

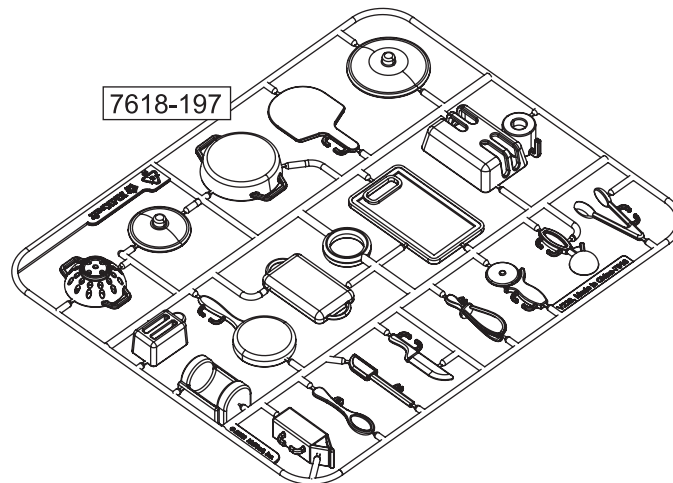

**ADULTS:** Fully remove parts from frame and discard the frame. File down any sharp points before giving parts to child.

**ADULTES :** Retirez entièrement les pièces du cadre et jetez le cadre. Limez toutes les parties pointues avant de donner les pièces à l'enfant.

**ADULTOS:** Retire completamente las piezas del marco y deseche el marco. Lime las puntas afiladas antes de dar las piezas al niño.

**ERWACHSENE:** Entfernen Sie die Teile vollständig vom Rahmen und entsorgen Sie den Rahmen.  
Feilen Sie alle scharfen Stellen ab, bevor Sie die Teile an Ihr Kind weitergeben.

**ADULTI:** Rimuovere completamente le parti dal telaio e gettare il telaio. Limare eventuali punti taglienti prima di consegnare i pezzi al bambino.

