



**INSTRUCTIONS D'ASSEMBLAGE
ASSEMBLY INSTRUCTIONS**

**BUREAU -
48" L / NATUREL / METAL BLANC**

**COMPUTER DESK -
48" L / NATURAL / WHITE METAL**



**POUR DE L'ASSISTANCE OU POUR COMMANDER
DES PIÈCES CONTACTEZ NOTRE DÉPARTEMENT
DE SERVICE À LA CLIENTÈLE.**

**FOR ASSISTANCE OR TO ORDER PARTS
CONTACT OUR CUSTOMER SERVICE DEPARTMENT**

LISTE DES PIÈCES PARTS LIST

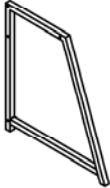
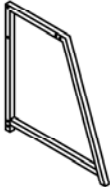
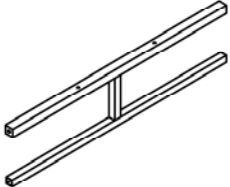
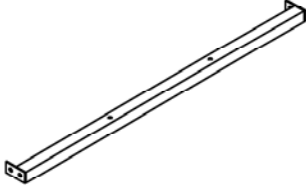
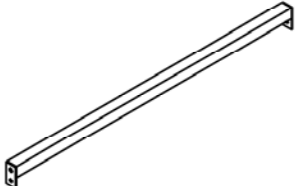
PIÈCE / PART #	IMAGE	DESCRIPTION	QTY / QTÉ
1		FRONT FACING RIGHT LEG PATTE AVANT DROITE	1
2		FRONT FACING LEFT LEG PATTE AVANT GAUCHE	1
3		STRETCHER CHÂSSIS	1
4		STRETCHER CHÂSSIS	1
5		CONNECTOR CONNECTEUR	1



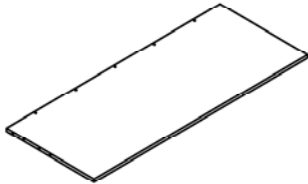
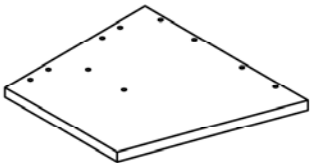
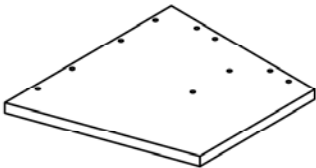
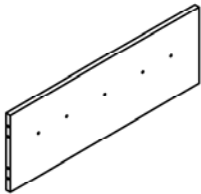
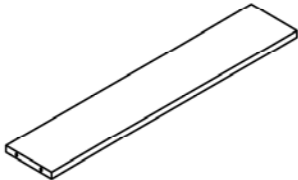

LISTE DES PIÈCES
PARTS LIST

PIÈCE / PART #	IMAGE	DESCRIPTION	QTY / QTÉ
6		DESK TOP SURFACE DU BUREAU	1
7		RIGHT SIDE FACING PANEL PANNEAU DE CÔTÉ DROIT	1
8		LEFT SIDE FACING PANEL PANNEAU DE GAUCHE	1
9		BACK PANEL PANNEAU ARRIÈRE	1
10		SHELF PANEL PANNEAU DE TABLETTE	1

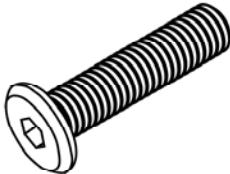
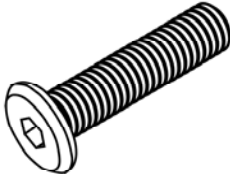

LISTE DES PIÈCES DE MONTAGE

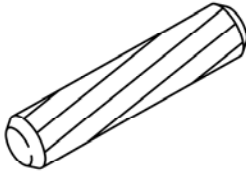
HARDWARE LIST

PIÈCE / PART #	IMAGE	DESCRIPTION	QTY / QTÉ
A		ASSEMBLING BOLT - Ø 1/4" X 1/2" BOULON D'ASSEMBLAGE - Ø 1/4" X 1/2"	4
B		ASSEMBLING BOLT - Ø 1/4" X 1 1/8" BOULON D'ASSEMBLAGE - Ø 1/4" X 1 1/8"	4
C		ASSEMBLING BOLT - Ø 1/4" X 1 1/2" BOULON D'ASSEMBLAGE - Ø 1/4" X 1 1/2"	8
D		ASSEMBLING SCREW - Ø 1/4" X 1 1/2" VIS D'ASSEMBLAGE - Ø 1/4" X 1 1/2"	6
E		WOOD DOWEL - Ø 3/8" X 1 1/4" GOUJON DE BOIS - Ø 3/8" X 1 1/4"	12

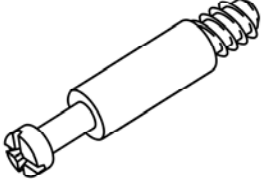

LISTE DES PIÈCES DE MONTAGE
HARDWARE LIST

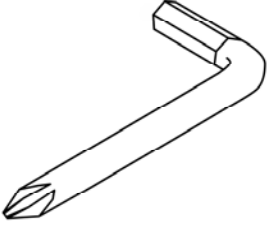
PIÈCE / PART #	IMAGE	DESCRIPTION	QTY / QTÉ
F		CAM LOCK SCREW - Ø 1/4" X 1 3/8" VIS CAM LOCK - Ø 1/4" X 1 3/8"	12
G		CAM LOCK CONNECTOR ÉCROU CAM LOCK	12
H		HEX KEY CLÉ HEXAGONALE	1

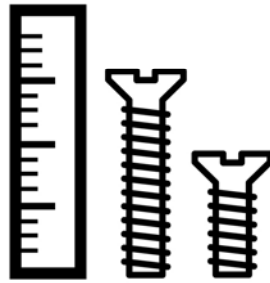

**OUTIL DE VÉRIFICATION DE DIMENSIONS DES PIÈCES
HARDWARE DIMENSIONS VERIFICATION TOOL**



ÉTAPE / STEP 1

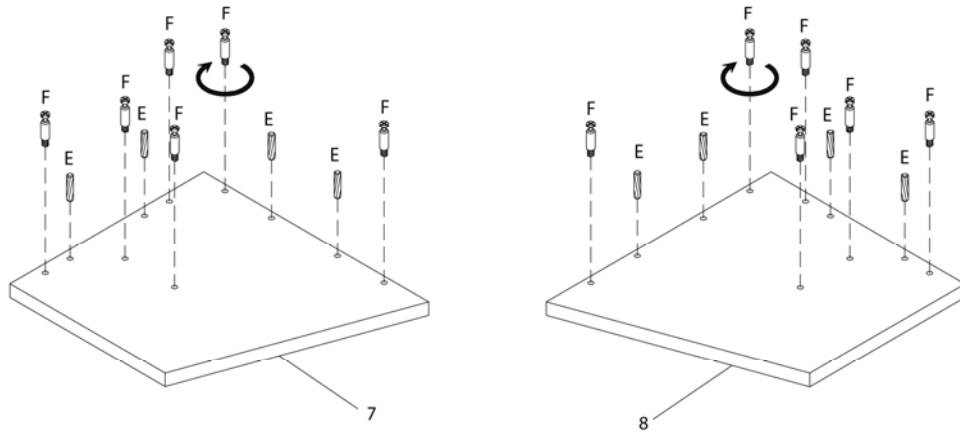

ÉTAPE / STEP 2

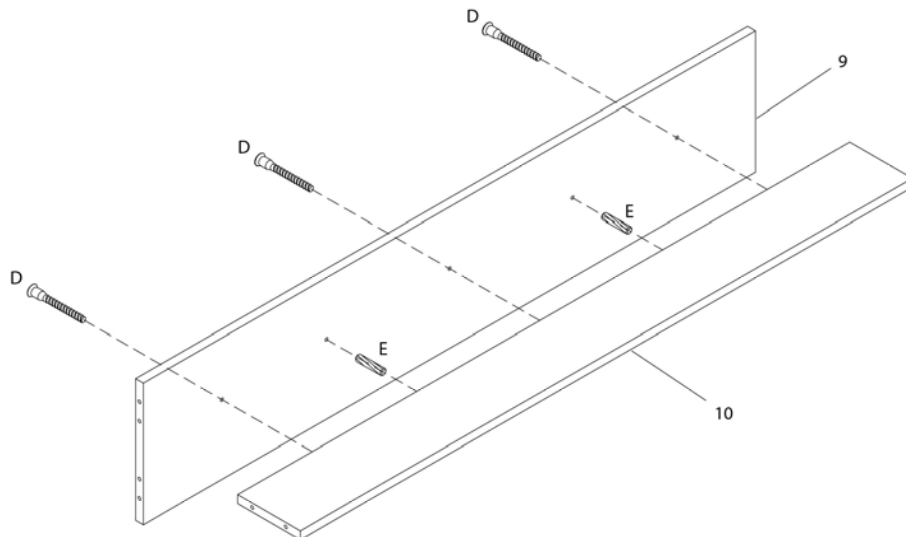

ÉTAPE / STEP 3

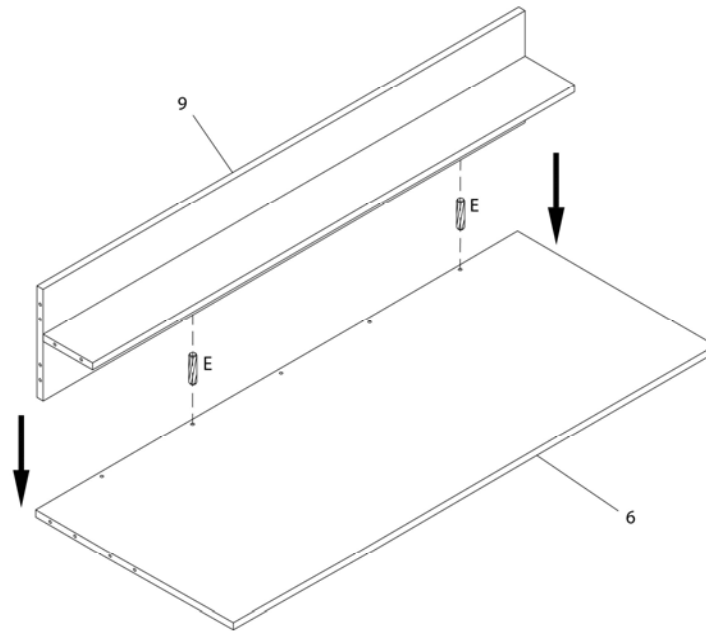

ÉTAPE / STEP 4

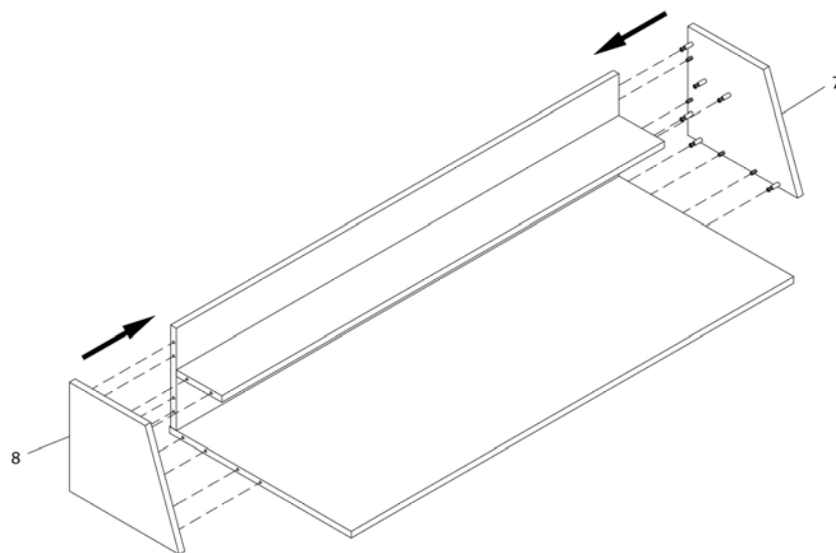

ÉTAPE / STEP 5

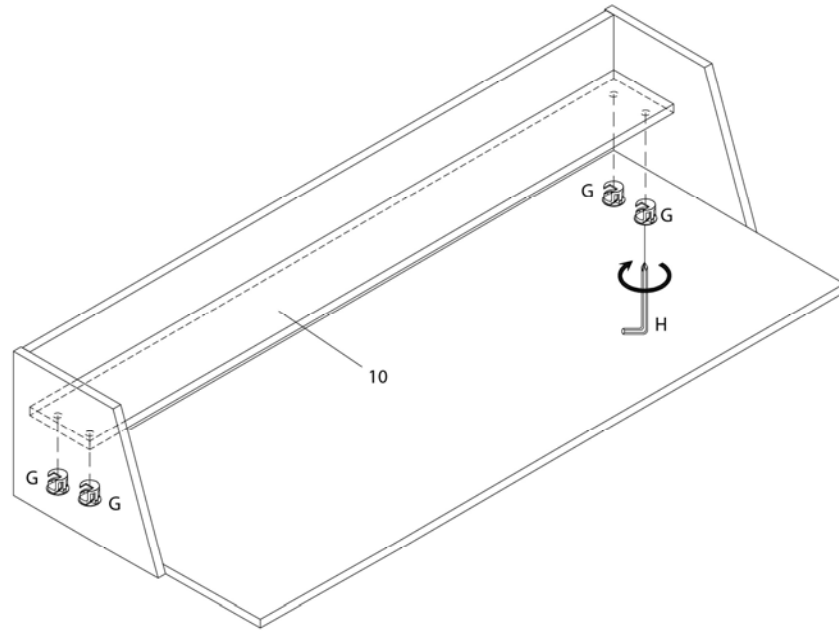

ÉTAPE / STEP 6

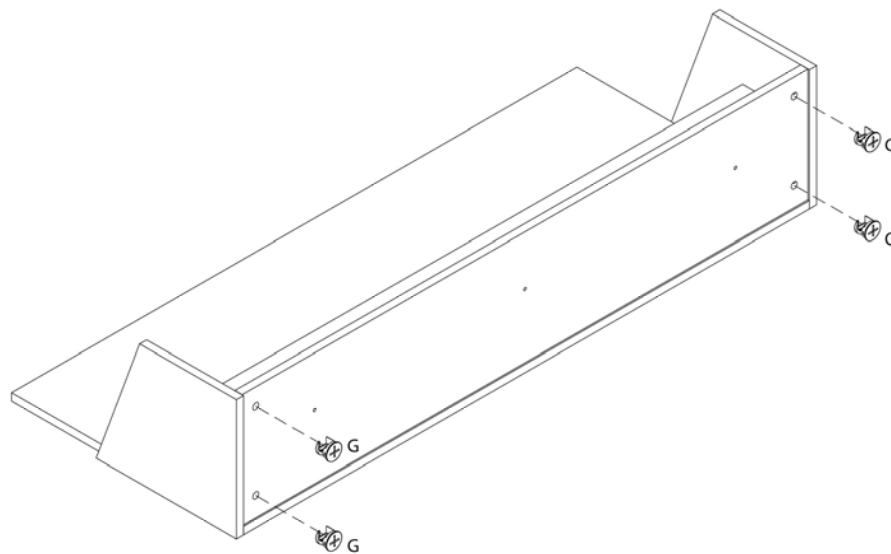

ÉTAPE / STEP 7

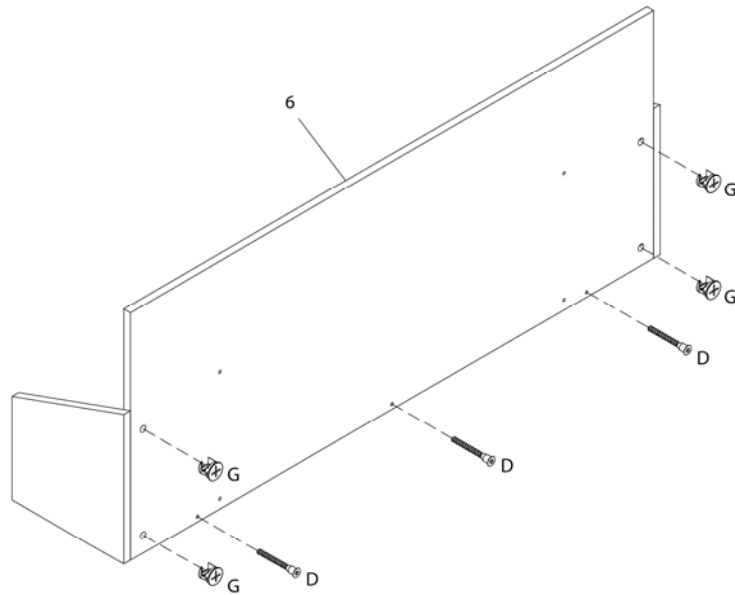

ÉTAPE / STEP 8

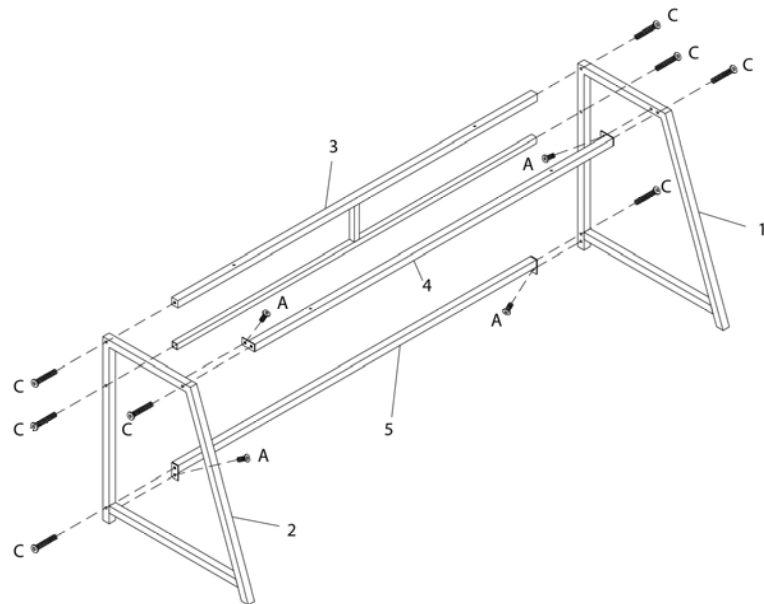

ÉTAPE / STEP 9

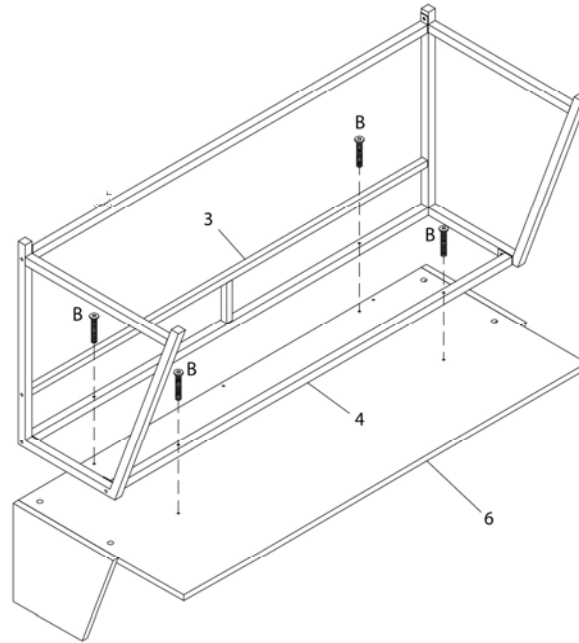

ÉTAPE / STEP 10

