

# *ASSEMBLY INSTRUCTIONS*



**WINE**  
**CABINET**

# ASSEMBLY INSTRUCTIONS

## ASSEMBLY TIPS:

1. Remove hardware from box and sort by size.
2. Please check to see that all hardware and parts are present prior to start of assembly.
3. Please follow attached instructions in the same sequence as numbered to assure fast & easy assembly.



### WARNING!

1. Don't attempt to repair or modify parts that are broken or defective. Please contact the store immediately.
2. This product is for home use only and not intended for commercial establishments.



ASSEMBLY TIME

90 MINUTES

## PARTS IDENTIFICATION

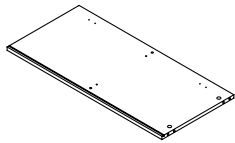
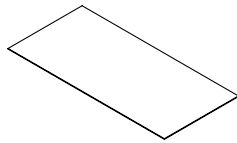
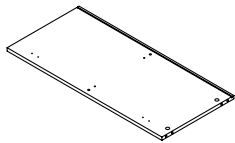
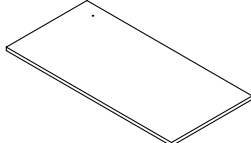
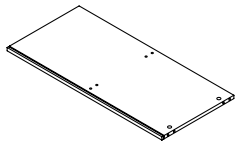
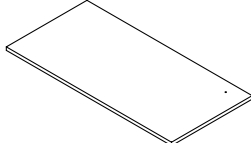
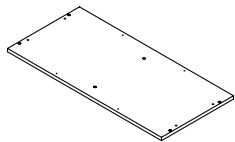
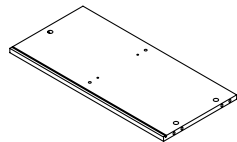
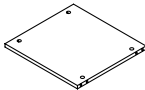
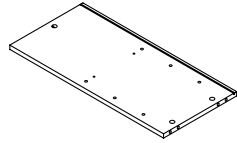
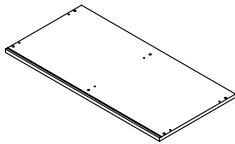
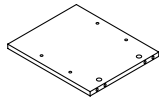
A	LEFT SIDE PANEL		1 PC	G	LOWER BACK PANEL		2 PCS
B	RIGHT SIDE PANEL		1 PC	H	LEFT DOOR		1 PC
C	MIDDLE DIVIDER PANEL		1 PC	I	RIGHT DOOR		1 PC
D	BOTTOM PANEL		1 PC	J	UPPER LEFT SIDE PANEL		1 PC
E	LOWER CROSS PANEL		2 PCS	K	UPPER RIGHT SIDE PANEL		1 PC
F	TOP PANEL		1 PC	L	UPPER DIVIDER PANEL		1 PC

### NOTE:

Phillips head screw driver is required in the assembly process; however, manufacturer does not provide this item.

M UPPER SMALL  
DIVIDER PANEL

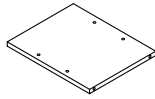

2 PCS

N UPPER  
CROSS PANEL

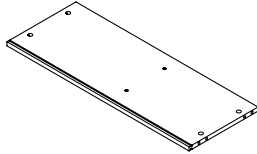

1 PC

O UPPER SMALL  
CROSS PANEL

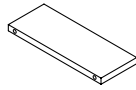

6 PCS

P UPPER SMALL  
TOP PANEL

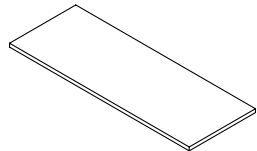

1 PC

Q MIDDLE  
BACK PANEL

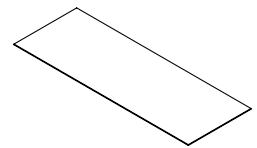

1 PC

R UPPER  
BACK PANEL

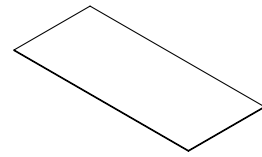

1 PC

S LEG FRAME

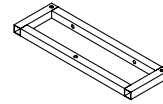

2 PCS

T UPPER  
CROSSBAR

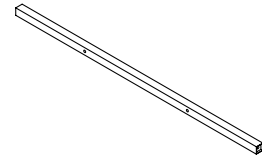

2 PCS

U LOWER  
CROSSBAR

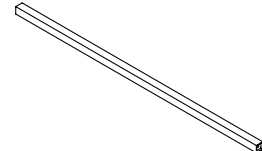

1 PC

V GLASS HOLDER

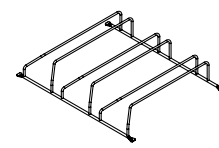









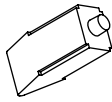

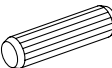
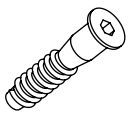
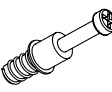
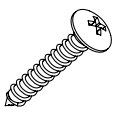

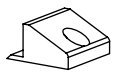
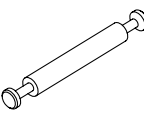

1 PC

**NOTE:**

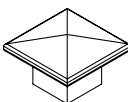
Phillips head screw driver is required in the assembly process; however, manufacturer does not provide this item.

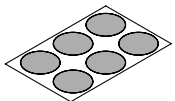
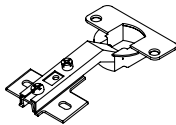
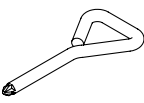
## HARDWARE IDENTIFICATION

<b>Z</b>							
NO	DESCRIPTION	FIGURE	Q'TY	NO	DESCRIPTION	FIGURE	Q'TY
1	GLUE 40g		1 PC	12	BOLT M6x43mm BLK		6 PCS
2	WOODEN DOWEL Ø8x30mm		48 PCS	13	BOLT Ø7x32mm BLK		4 PCS
3	CAM BOLT Ø7x35.5mm SR		22 PCS	14	SCREW Ø5x35mm BLK		4 PCS
4	CAM LOCK Ø15x12mm SR		26 PCS	15	FLOOR PROTECTOR 20x20mm		4 PCS
5	SCREW Ø4.5x42mm SR		8 PCS	16	ALLEN WRENCH 4mm SR		1 PC
6	WOODEN DOWEL Ø8x50mm		10 PCS	17	FIXER		6 PCS
7	CAM BOLT Ø7x63mm SR		2 PCS	18	FIXER SCREW Ø3x19mm SR		6 PCS
8	HANDLE BLK		2 PCS	19	SCREW Ø4x18mm SR		4 PCS
9	HANDLE BOLT BLK		2 PCS	20	STICKER Ø20mm		5 PCS
10	HINGE Ø35mm SR		4 PCS	21	SCREW DRIVER		1 PC
11	HINGE SCREW Ø4x15mm SR		16 PCS				

Z10 not included in blister packaging.

**NOTE:**

Phillips head screw driver is required in the assembly process; however, manufacturer does not provide this item.



## STEP 2

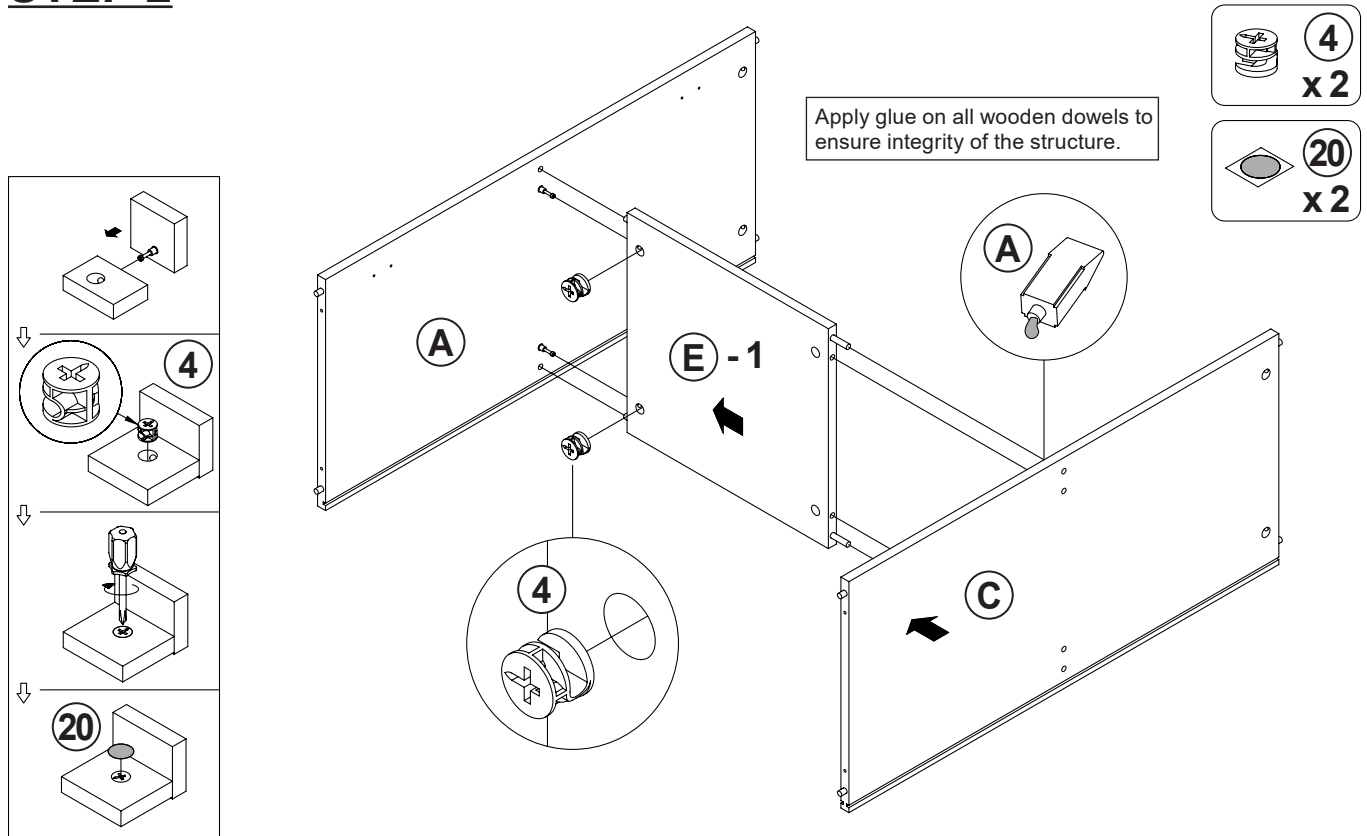

## STEP 3

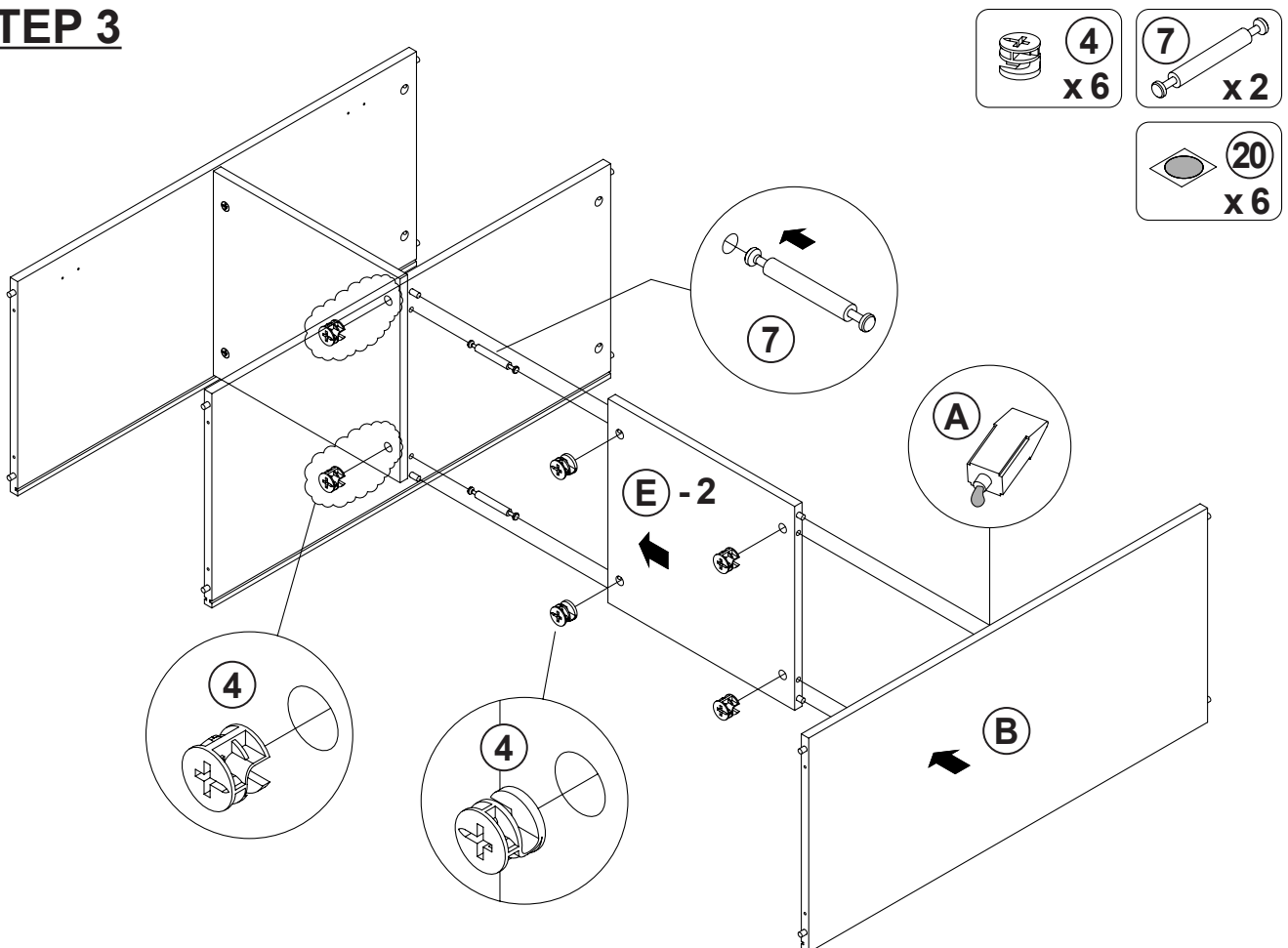

## STEP 4

Apply glue on all wooden dowels to ensure integrity of the structure.

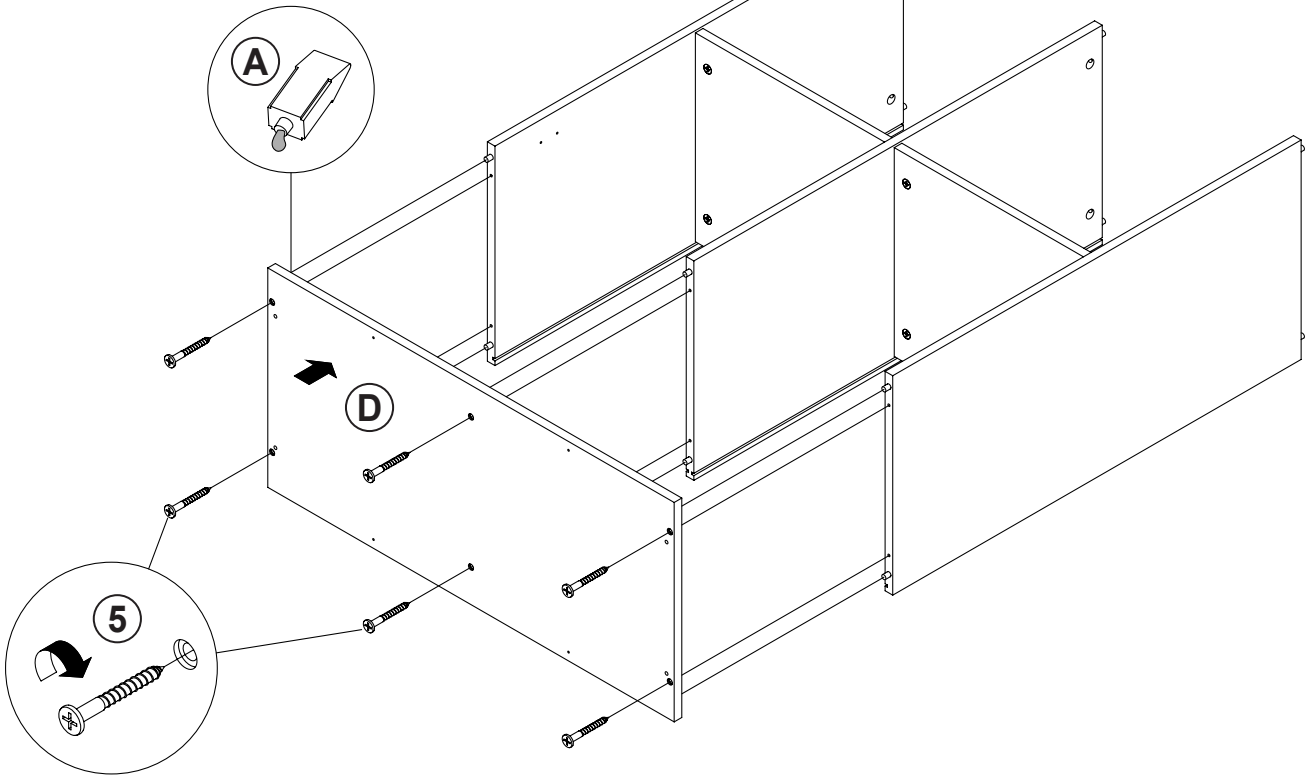
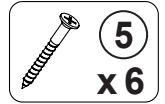

## STEP 5

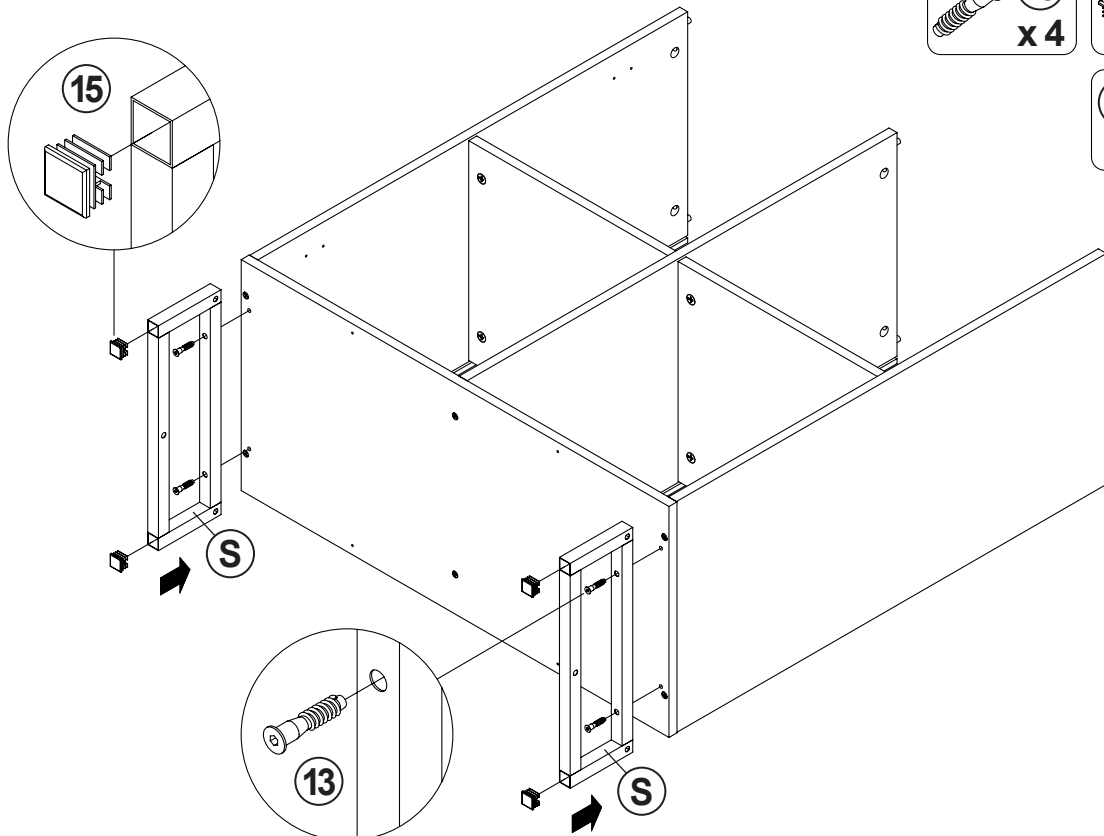
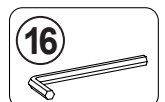
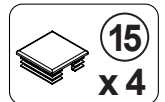
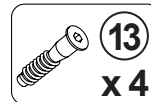

## STEP 6

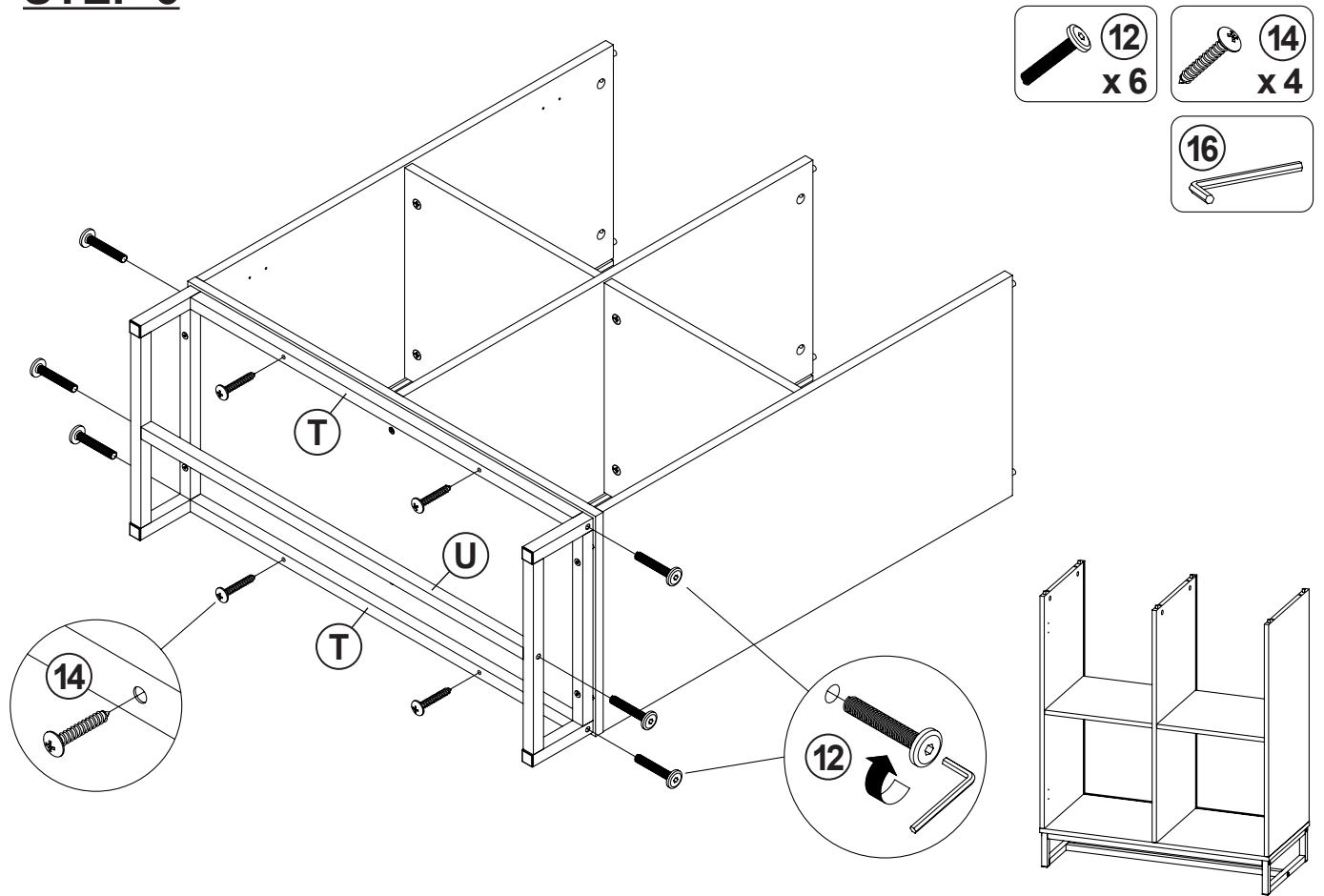

## STEP 7

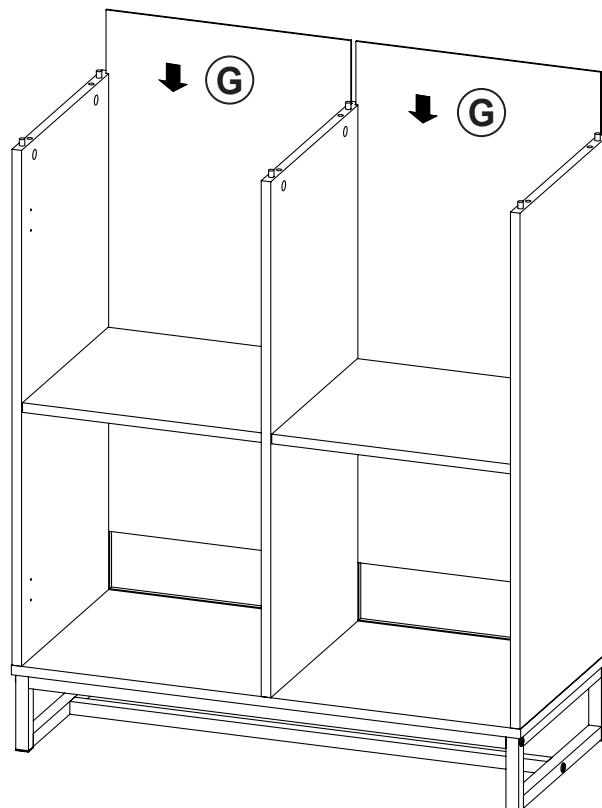

## STEP 8

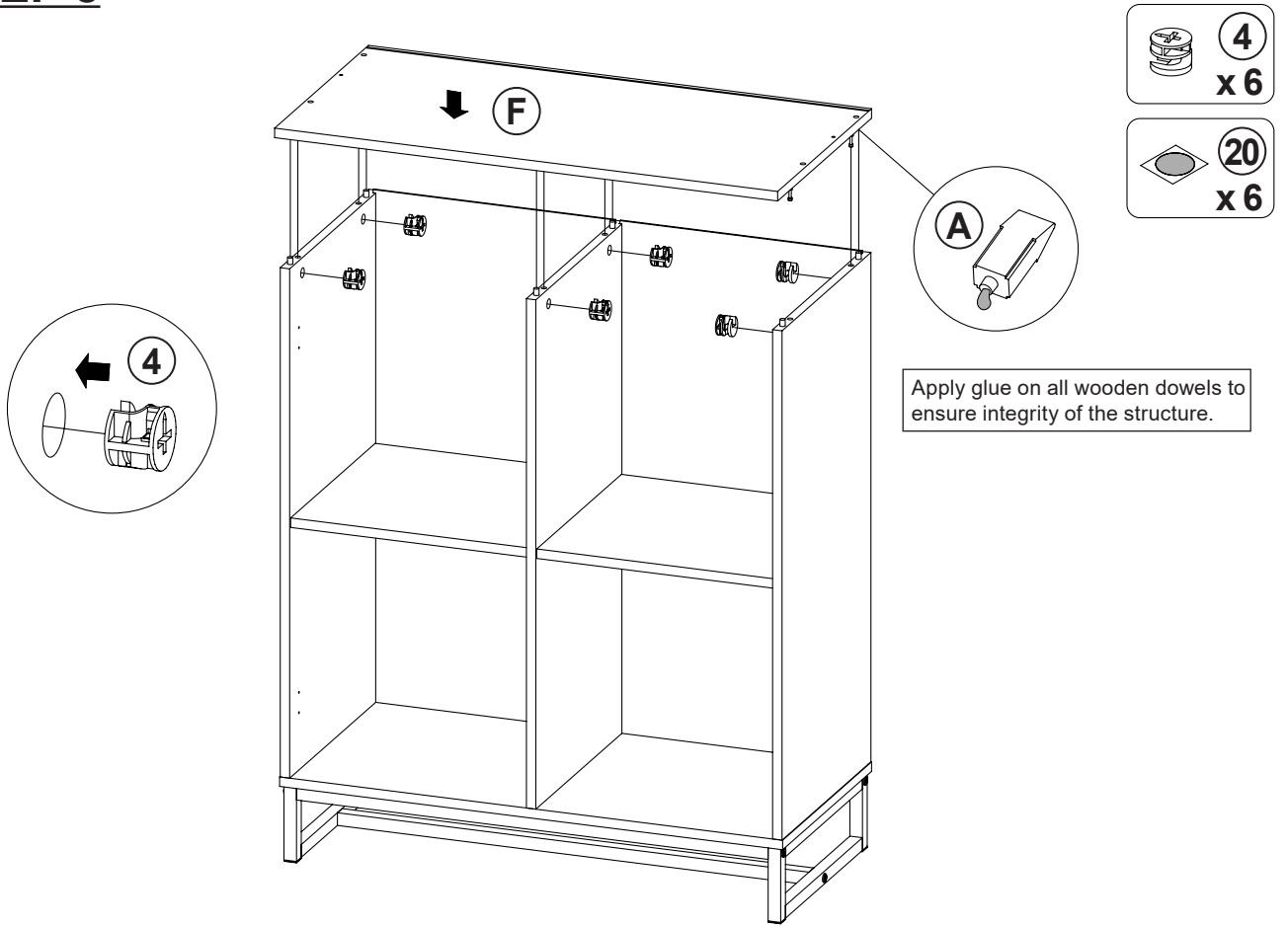

## STEP 9

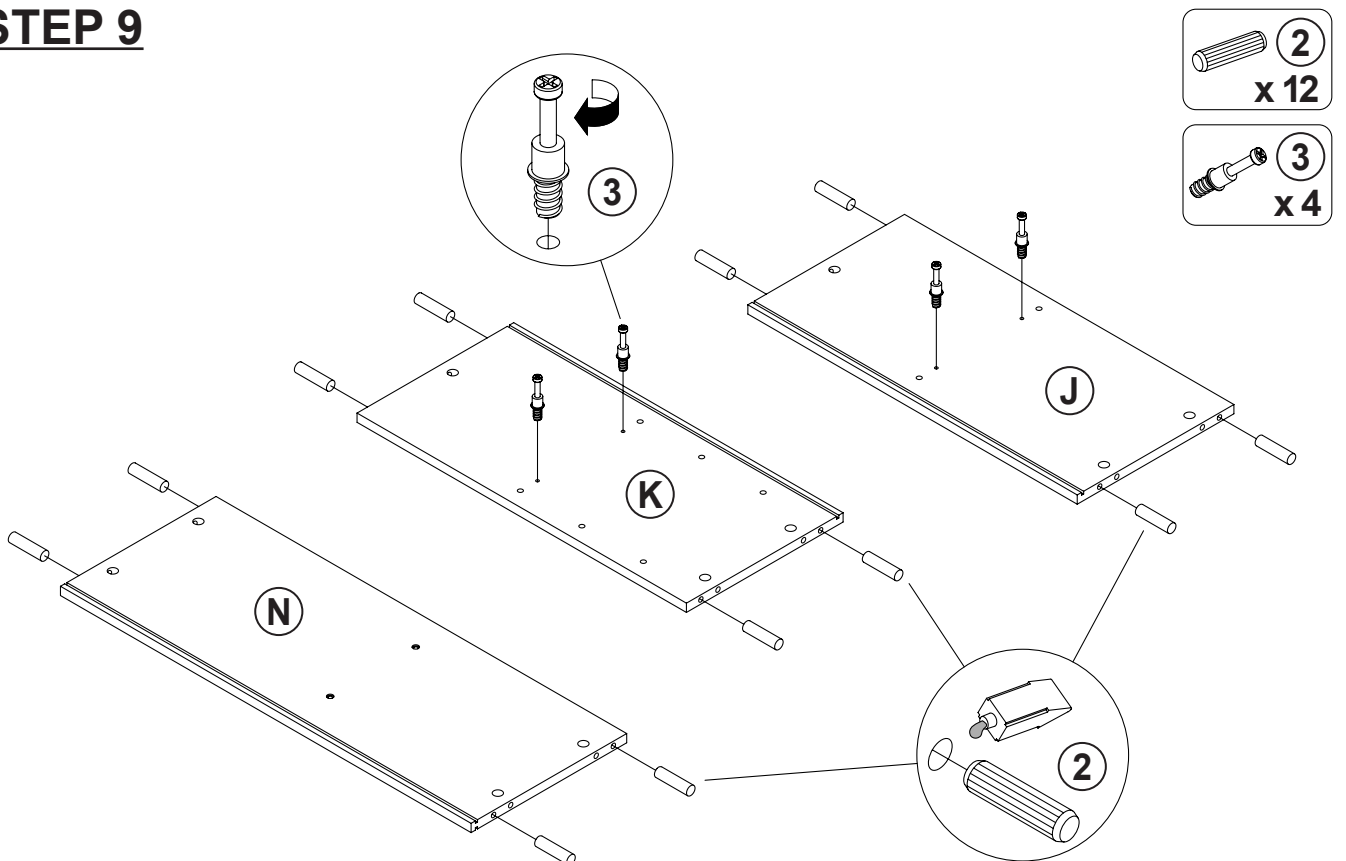

## STEP 10

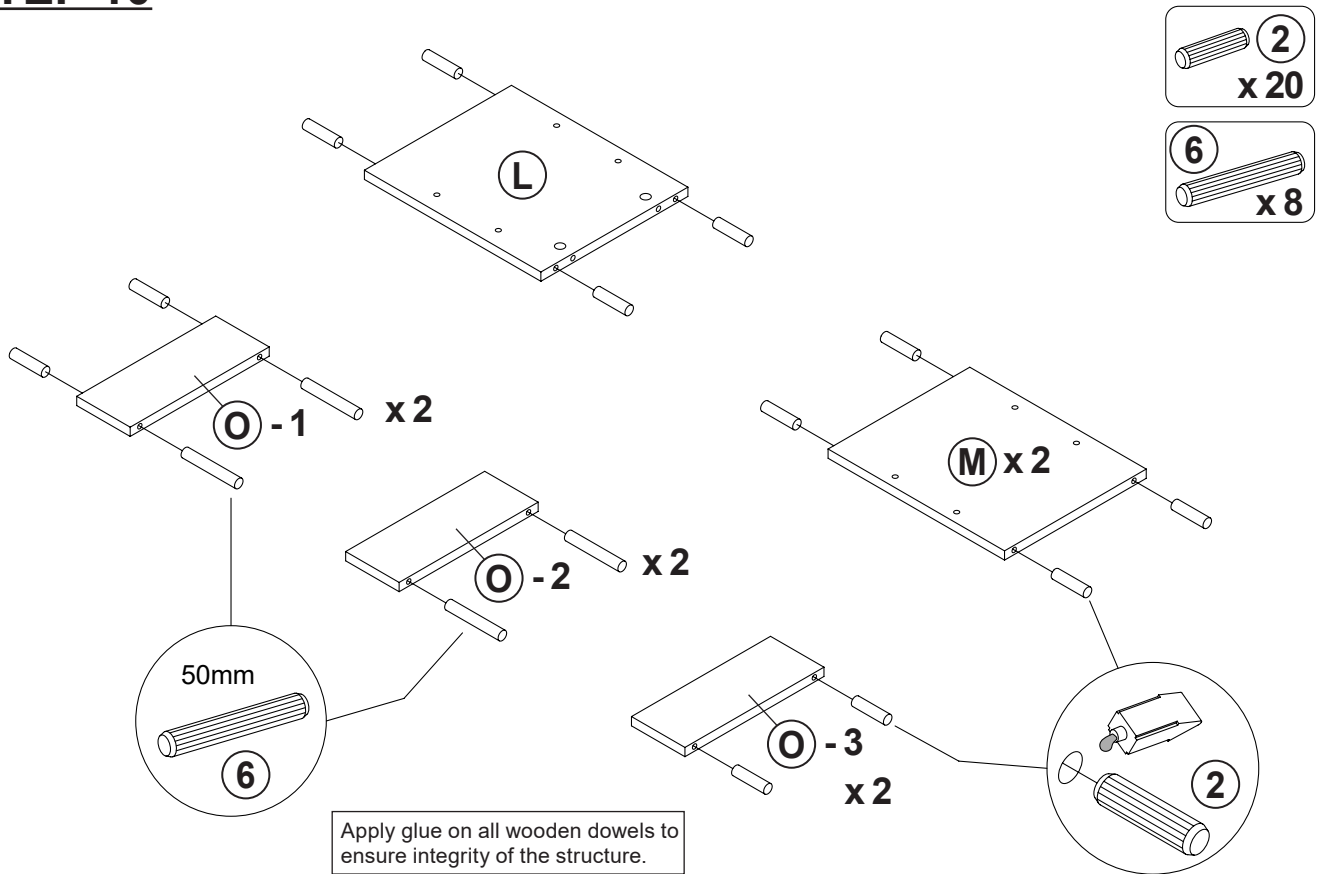

## STEP 11

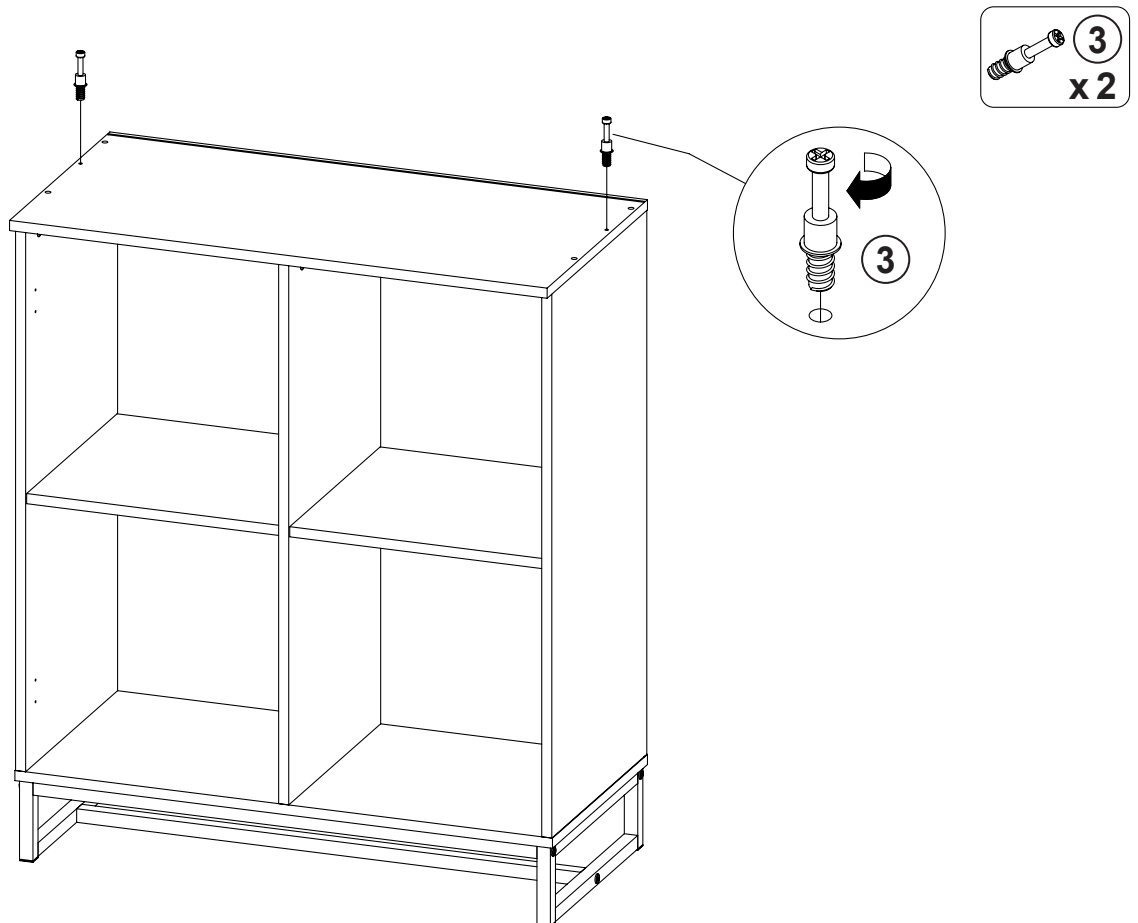

## STEP 12

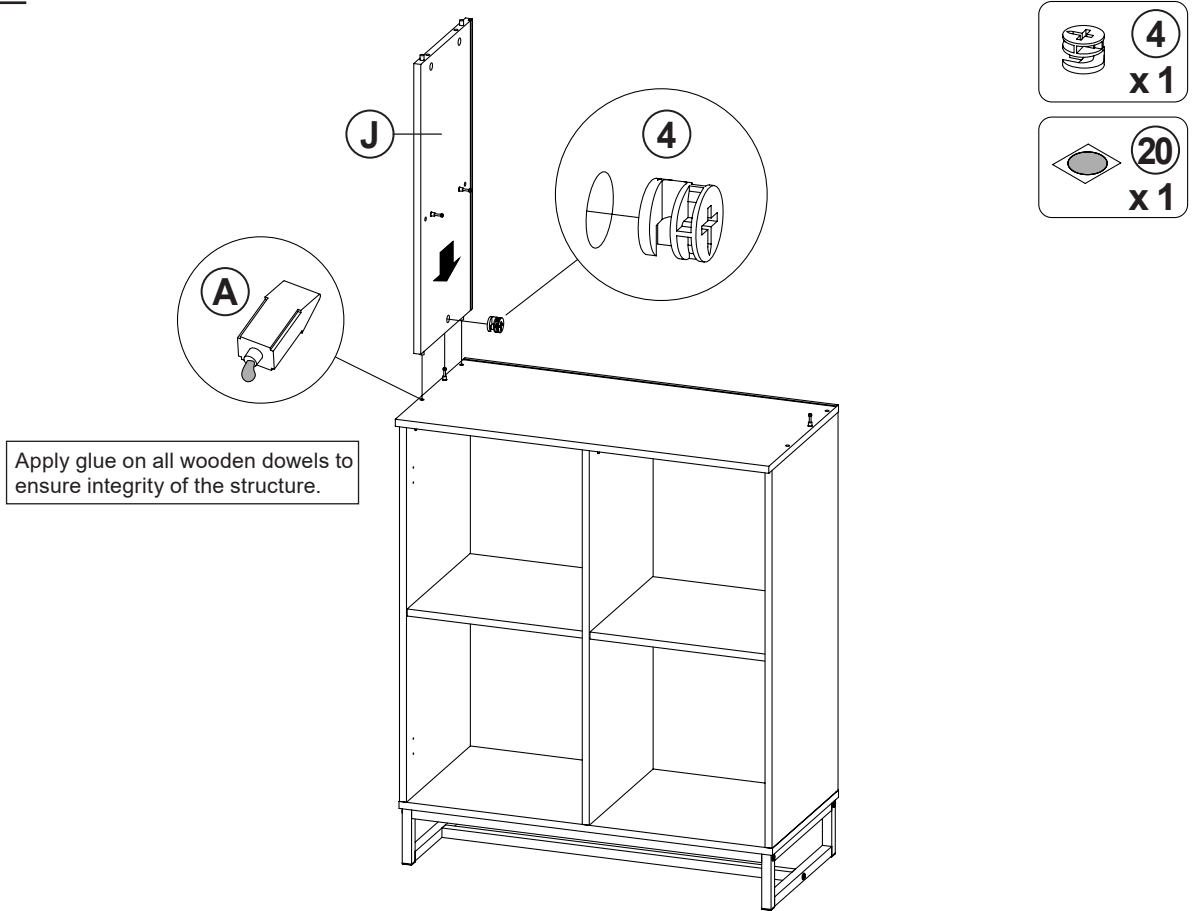

## STEP 13

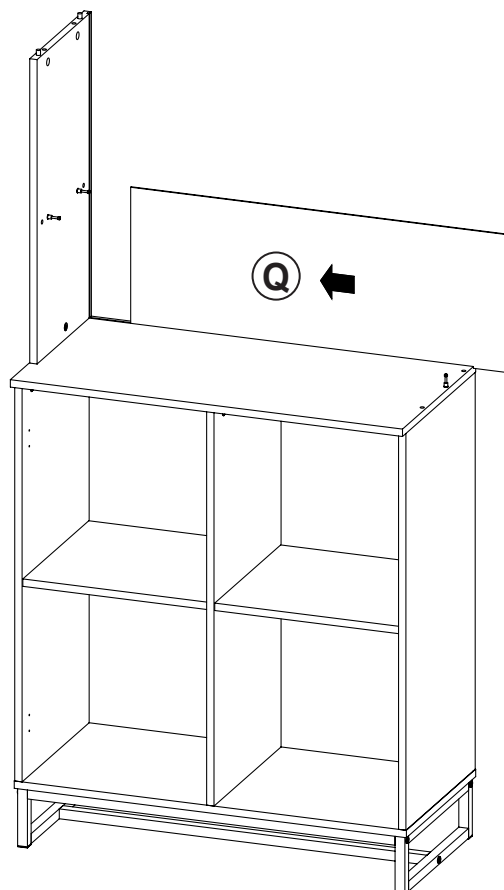

## STEP 14

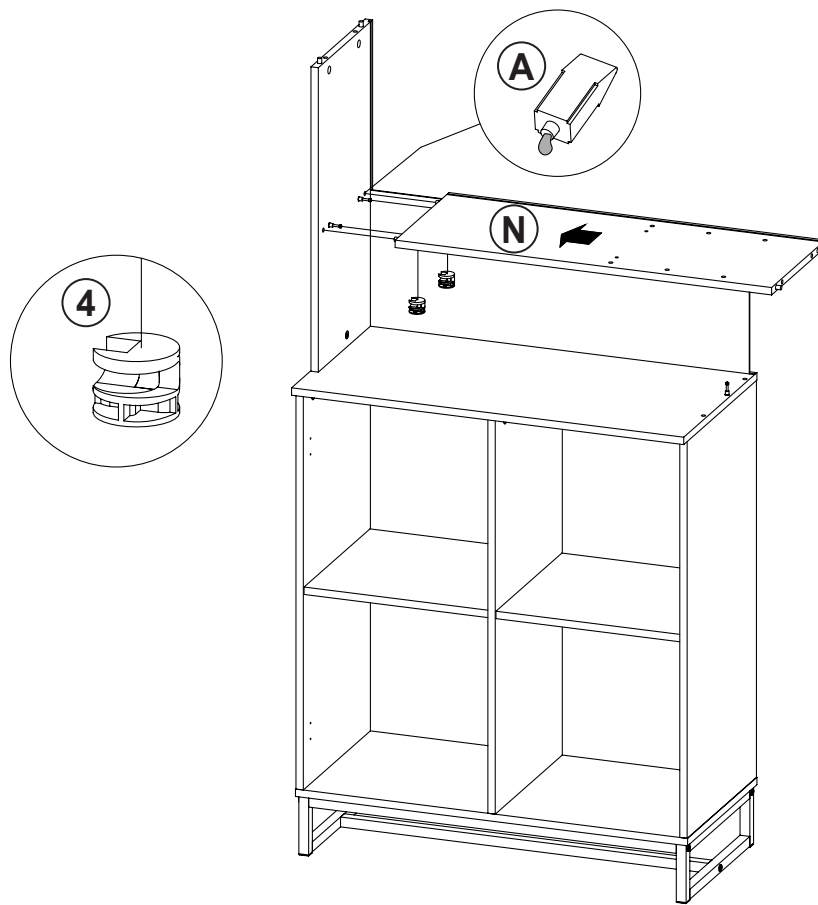

## STEP 15

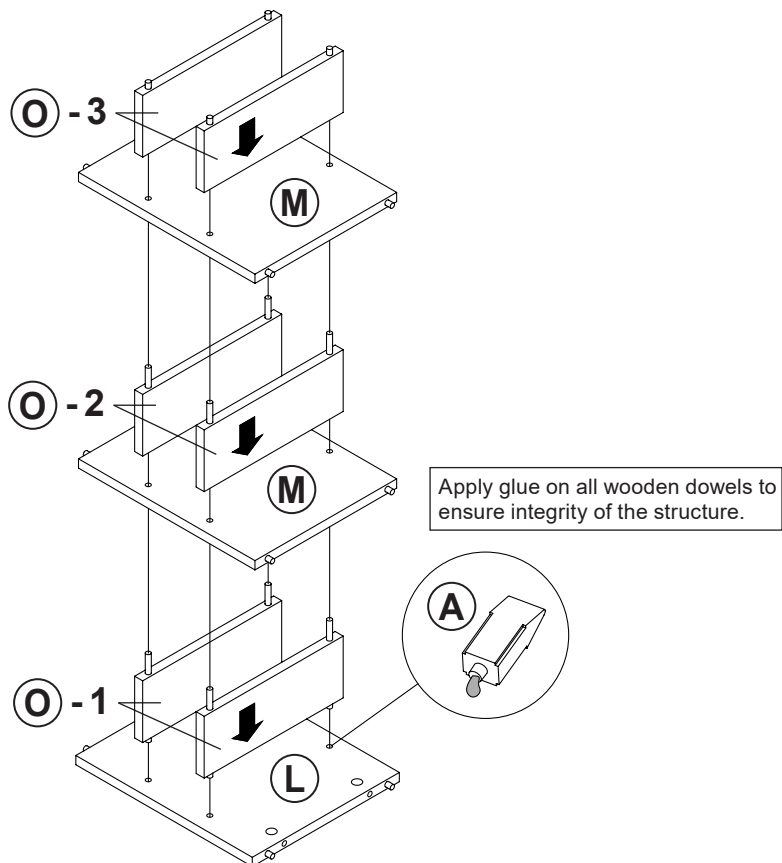

## STEP 16

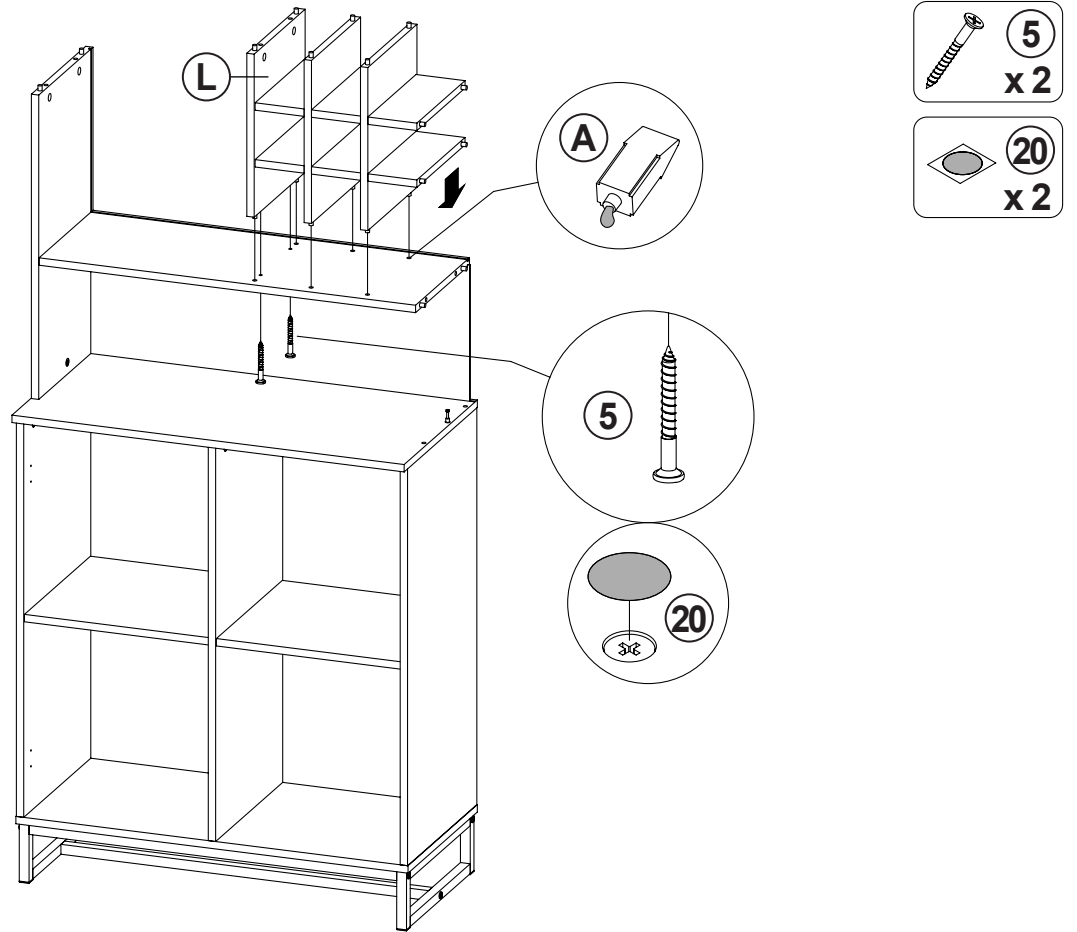

## STEP 17

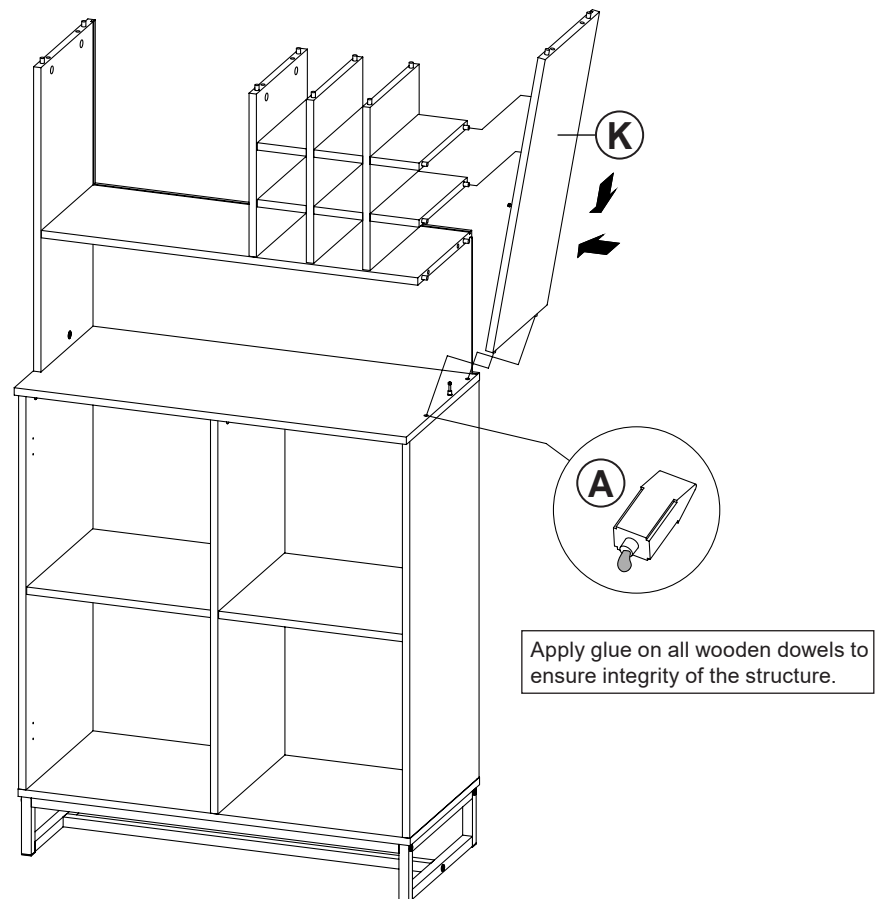

## STEP 18

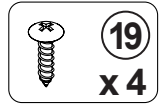
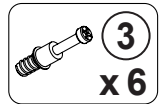
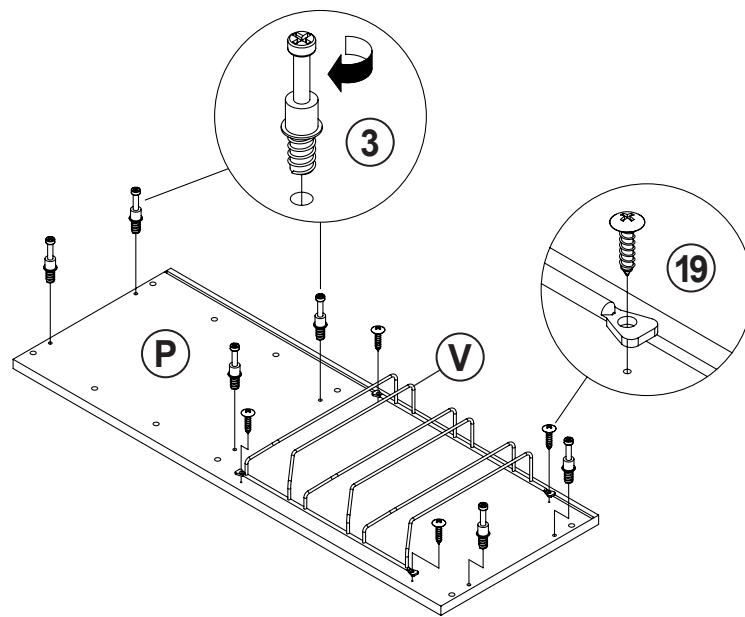

## STEP 19

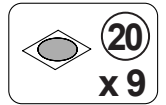
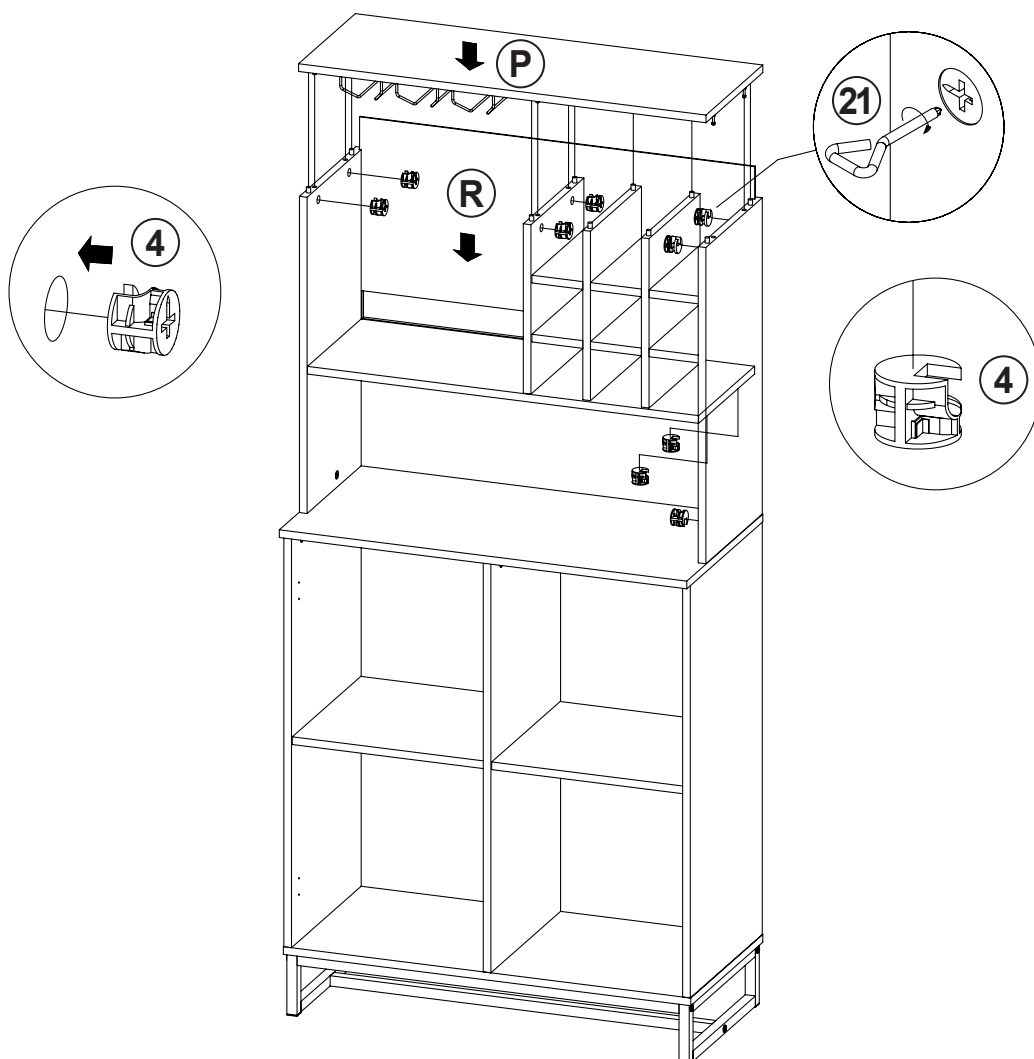

## STEP 20

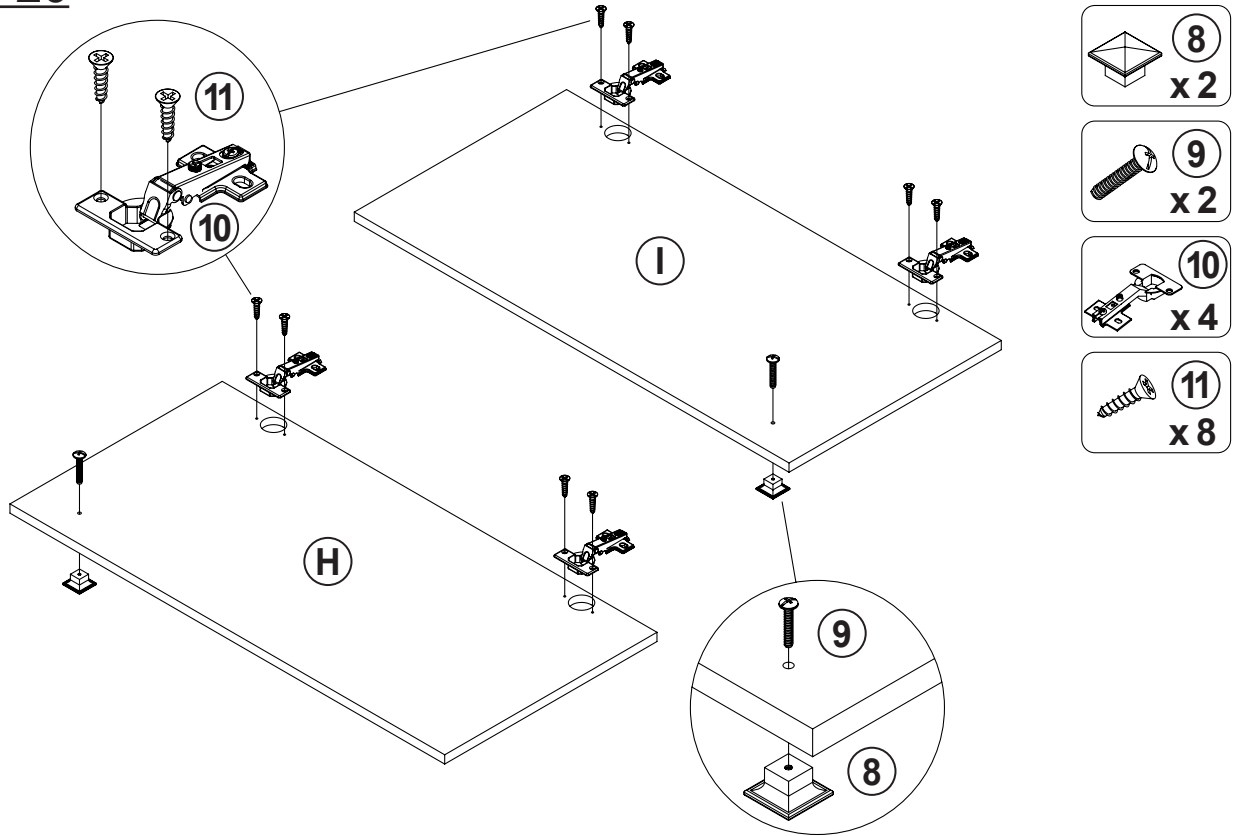

## STEP 21

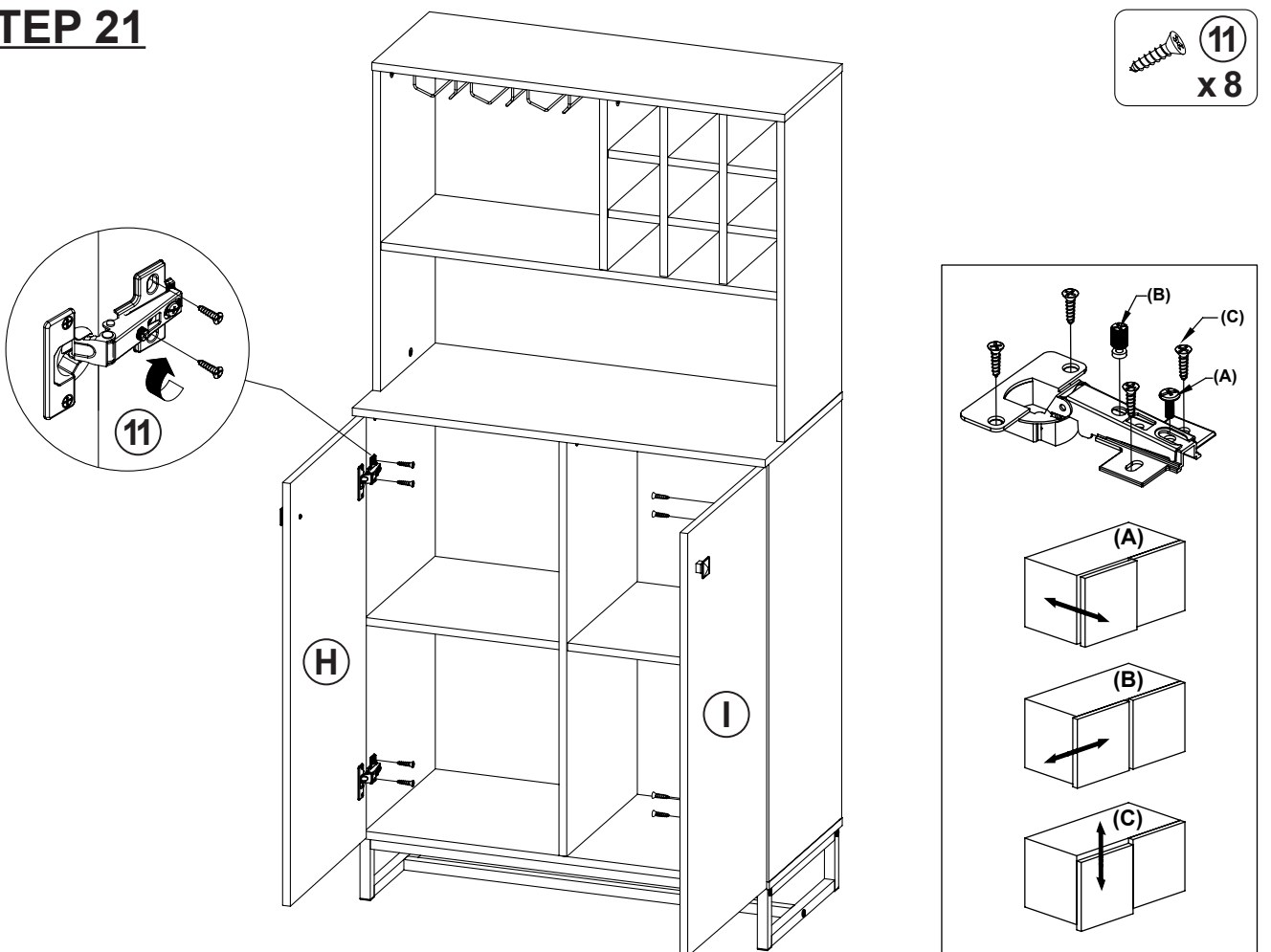

## STEP 22

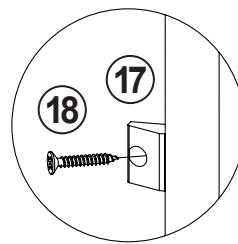
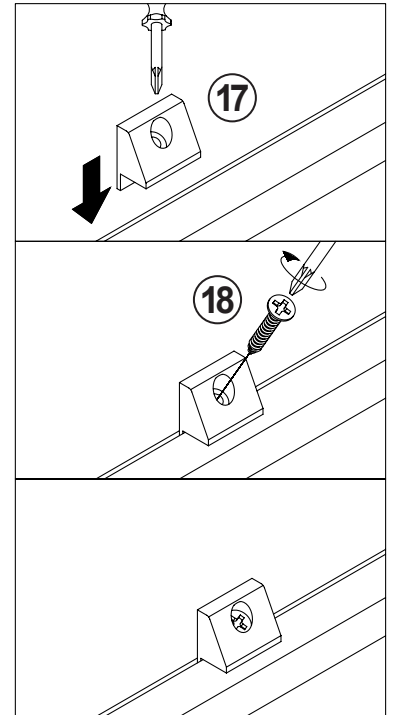
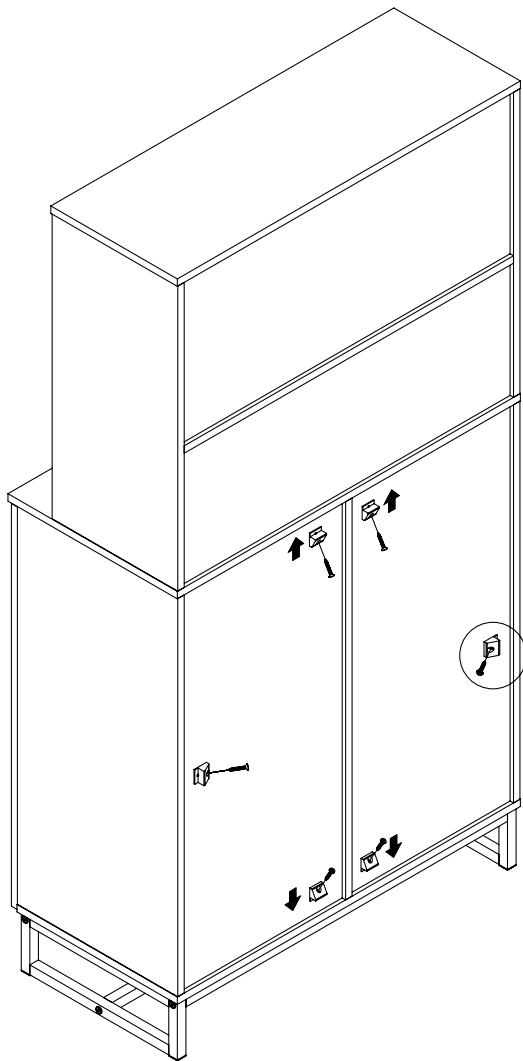

## STEP 23

COMPLETE

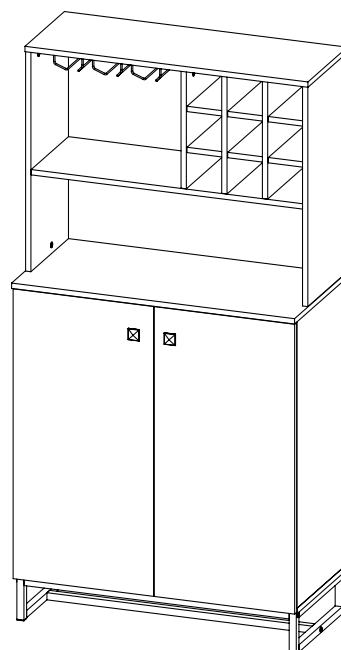



# ANTI-TIPPING INSTALLMENT INSTRUCTIONS

## FURNITURE TIPPING RESTRAINT

### WARNING

Injury may result from tipping furniture.  
This restraint may protect against tipping furniture.  
Do not allow children to climb on furniture.  
This restraint is not a substitute for proper adult supervision.  
Failure to detach this restraint before moving the furniture may result in injury and damage.

This restraint must be screwed to a wood stud on the wall, using the long screw provided.

### STEP 1

Secure the bracket to the back top of the unit, using the short screw provided, as shown in the drawing.

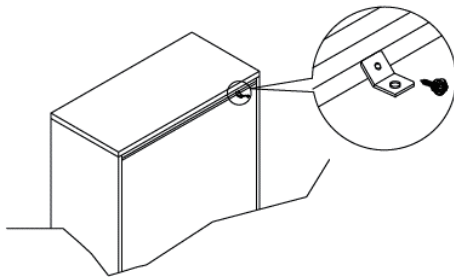

### STEP 2

Locate the wood stud on the wall, and secure the other bracket, 2 inches below the back of the unit.

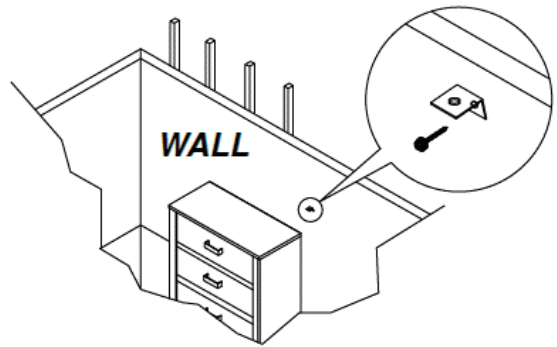

### STEP 3

Place the furniture into position so both mounting brackets are vertically in line. Lace the end of the restraint strap through the larger hole in each mounting bracket. Bring both ends together and slide the flat end through the locking end, and drag it through, until the slack is removed. Ensure that the strap is securely laced and locked.

