

# ASSEMBLY INSTRUCTIONS SHELF

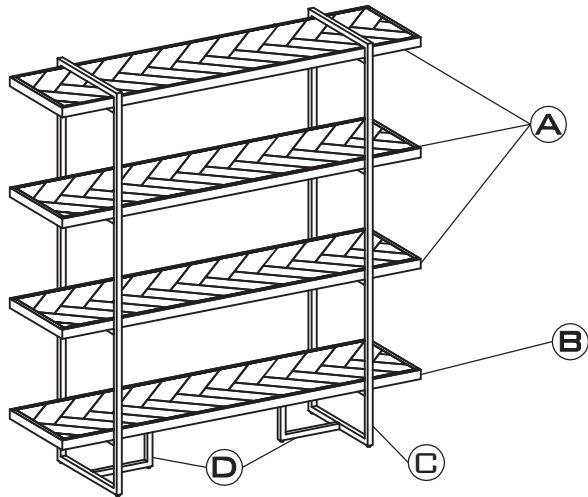

## PARTS CHECK LIST

CODE	COMPONENTS	QTY
(A)	TOP PANEL	x03
(B)	BOTTOM PANEL	x01
(C)	METAL LEG FRAME	x02
(D)	LEG FRAME	x02

## HARDWARE CHECK LIST

CODE	DESCRIPTION	QTY
01	LONG BOLT	x18
02	SHORT BOLT	x04
03	METAL BRACKET	x04
04	SCREW	x04
05	PLASTIC STRAP	x02
06	NYLON WALL STRAP	x02
07	ALLEN KEY	x01

- PLEASE DO NOT DISCARD ANY OF THE PACKAGING UNTIL YOU HAVE CHECKED ALL THE PARTS AND THE PACKS OF HARDWARE.  
 - BEFORE YOU BEGIN TO ASSEMBLE YOUR NEW PIECE OF FURNITURE, PLEASE CHECK TO ENSURE THAT ALL PARTS HAVE BEEN SUPPLIED.  
 - FOLLOW INSTRUCTIONS CLOSELY AS DEVIATION FROM THEM MAY VOID YOUR WARRANTY AND PRESENT A POSSIBLE SAFETY RISK.  
 - IT IS RECOMMENDED THAT ASSEMBLY IS DONE ON A SOFT SURFACE LIKE CARPET TO AVOID ANY DAMAGE.  
 - PERIODICALLY CHECK AND RE-TIGHTEN ANY FASTENERS. WIPE DOWN ALL SURFACES WEEKLY WITH A CLEAN CLOTH. DO NOT CLEAN ANY SURFACES WITH HARSH ABRASIVES OR CHEMICALS.

**TOOLS REQUIRED  
NOT SUPPLIED**

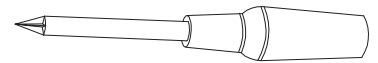

1.

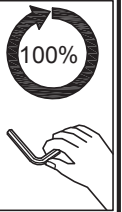
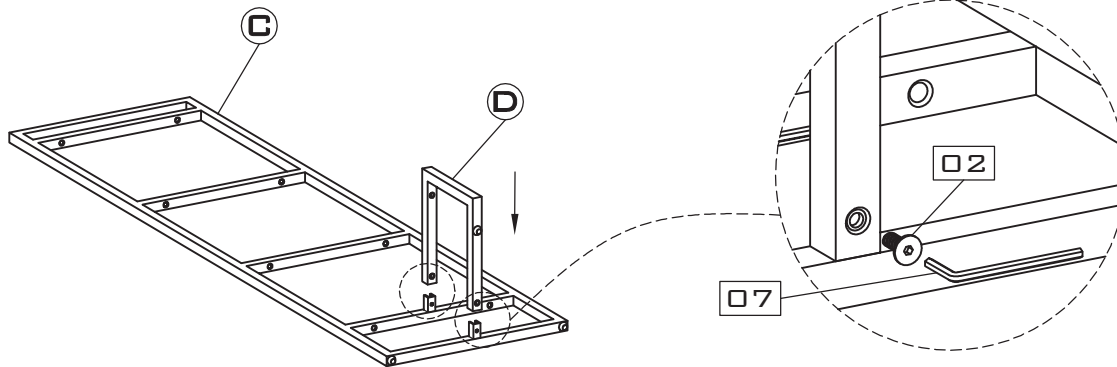

2.

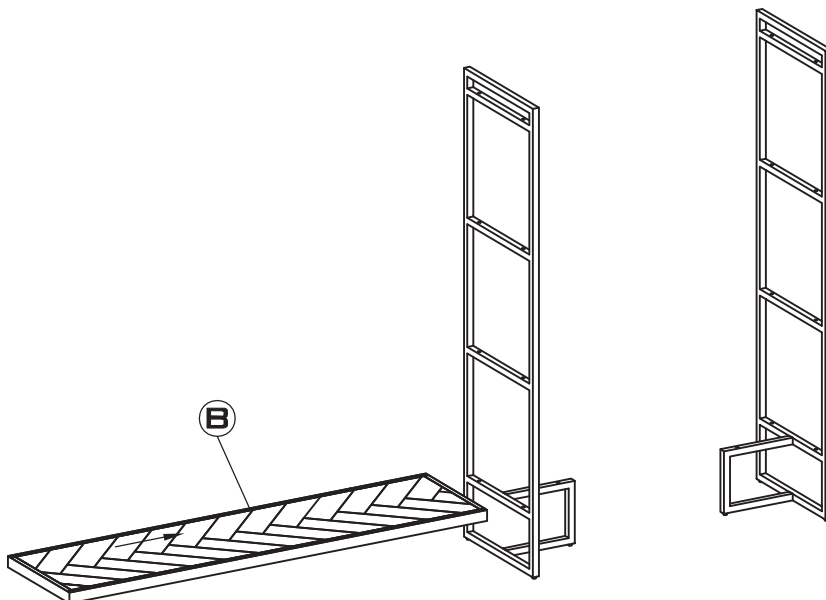

3.

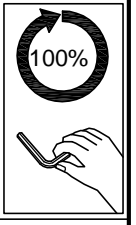
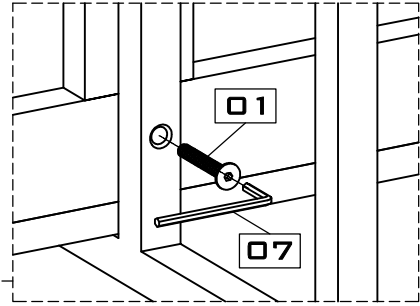
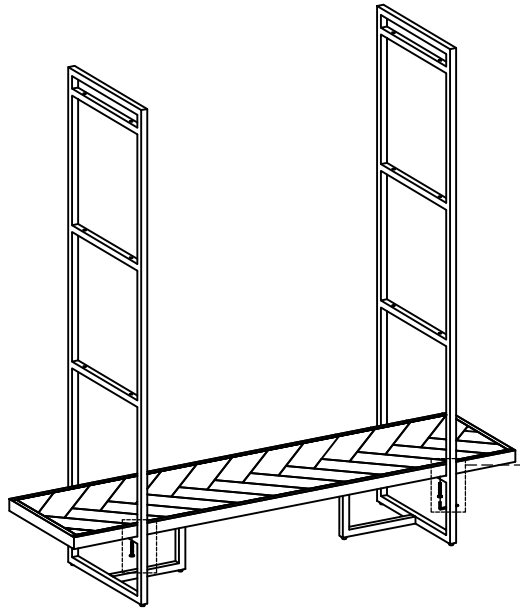

4.

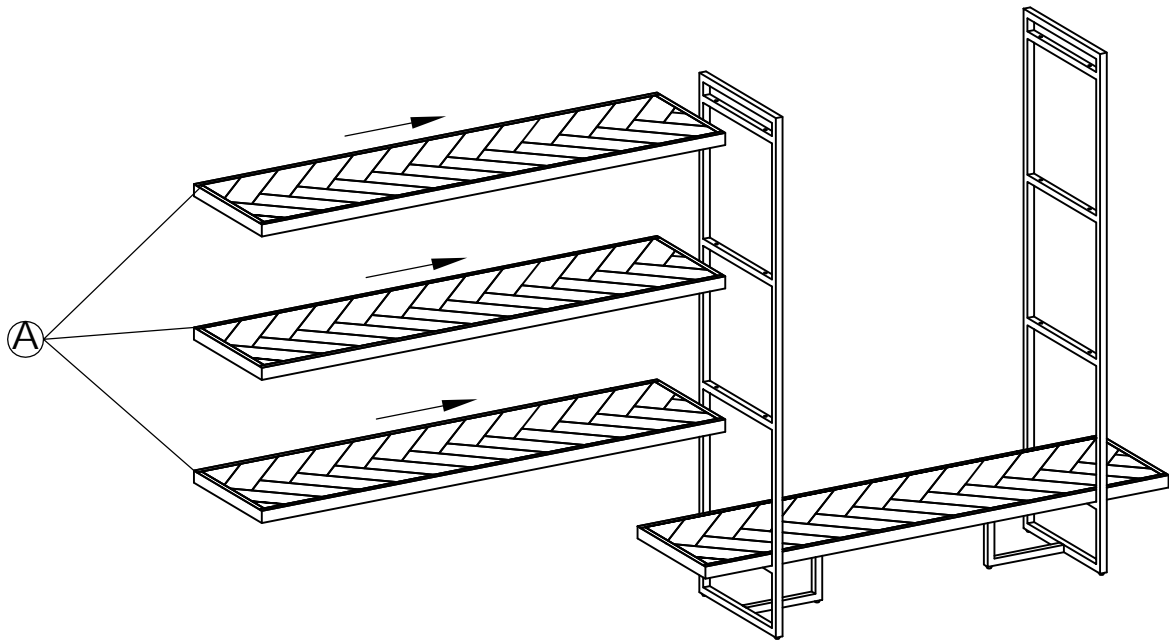

5.

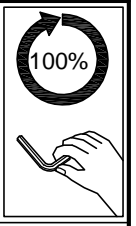
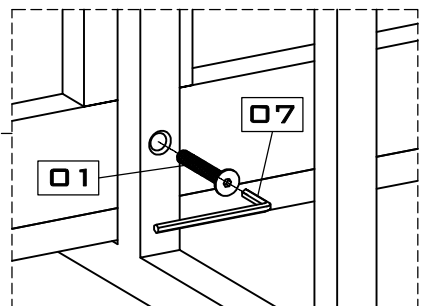
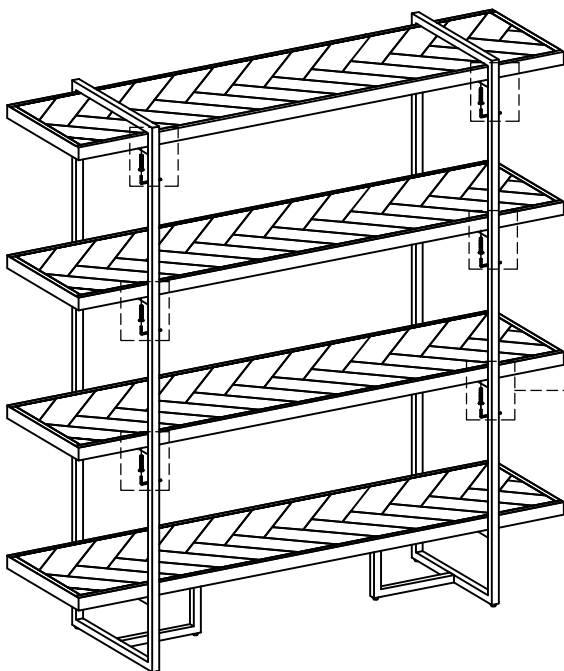

6.

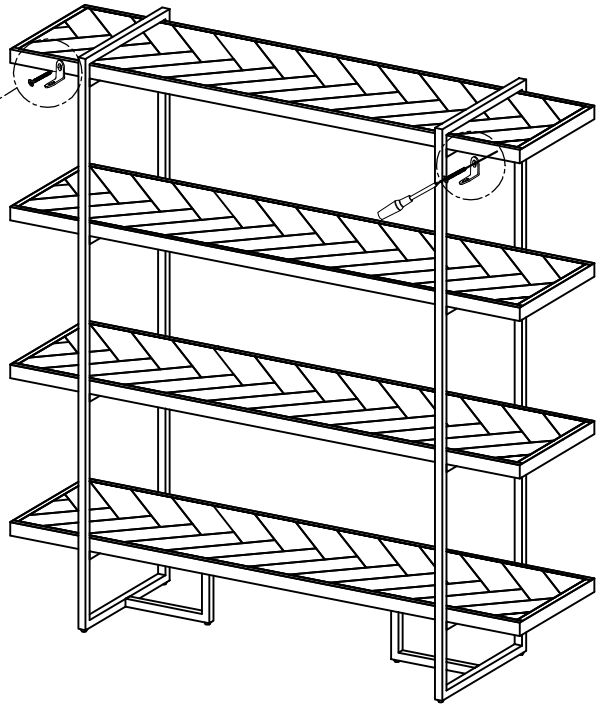
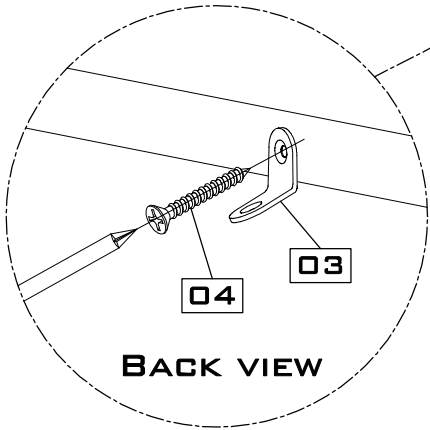

7.

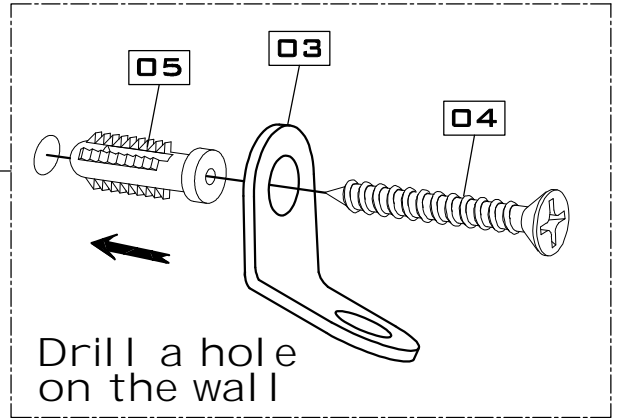
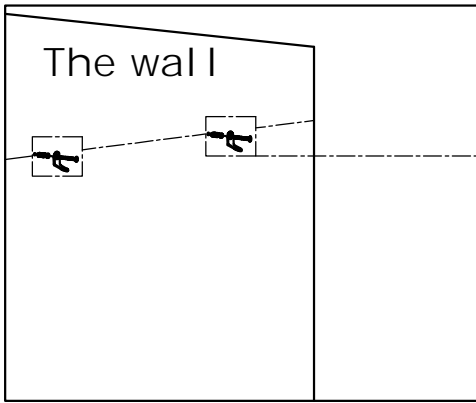

8.

