















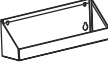

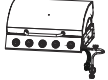















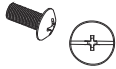



No.	#	QYT / CANT. / QTÉ	Description / Descripción / Description	Image / Imagen / Image
1	EJDB17H4B-RGC	1	Bottom shelf Estante inferior Etagere inferieure	
2	AJQPGDZ01	1	Screw bushing Buje del perno de fijación de la bombona Douille de vis	
3	07-QPG-05-SI	1	LP cylinder screw Perno de fijación de la bombona Vis de bouteille de gaz	
4	05-WXL-20	4	Caster Rueda Roulette	
5	EJCB03	1	Side panel Panel lateral Panneau latéral	
6	EJCB04-RGC	1	Side panel Panel lateral Panneau latéral	
7	EJHB024B	1	Rear panel Panel trasero Panneau arrière	
8	EJGDSJB01	2	Triangle support plate Placa de soporte triangular Plaque de support triangulaire	
9	EJQPDG02-RGC	1	LP cylinder barrier bar Barra de seguridad para la bombona de gas Barre de barrière de bouteille de gaz	
10	EJHL05H4B	1	Cart front beam Barra frontal del carro Poutre avant du chariot	
11	EJQPGRB01-DS1	1	Thermal baffle Deflector térmico Panneau isolant	
12	EJLTGDBL02	1	Grease tray bracket (L) Fijación de Bandeja de recojida de grasa (I) Support du Lèchefrite (G)	
13	EJLTGDBR02	1	Grease tray bracket (R) Fijación de Bandeja de recojida de grasa (D) Support du Lèchefrite (D)	
14	EJSM044B-RGC -SS4	1	Cabinet door (L) Puerta del armario (I) Porte d'armoire (G)	
15	EJSM044B-RGC -SS4	1	Cabinet door (R) Puerta del armario (D) Porte d'armoire (D)	

No.	#	QYT / CANT. / QTÉ	Description / Descripción / Description	Image / Imagen / Image
16	EJMGDPL01	1	Beam connector (L) Unión de la barra (I) Connecteur de faisceau (G)	
17	EJMGDPR01	1	Beam connector (R) Unión de la barra (D) Connecteur de faisceau (D)	
18	EJBJGL01	1	Basket Cesta Panier	
19	04-GBS-2-01-200 -PG	2	Door handle Tirador de la puerta Poignée de la porte	
20	04-BSZ-03-BK	4	Handle sleeve Base de encastre del tirador Manche de poignée	
21		1	Main body Cuerpo principal Corps principal	
22	ET30-L	1	Side shelf Bandeja lateral Étagère latérale	
23	EB30-R	1	Side burner shelf Base del quemador lateral Étagère du bruleur d'appoint	
24	06-XNZ-6-01	1	Knob base Base de mando de regulación de llama Base du bouton	
25	06-XNL-6-14-BK -RGC	1	Knob Mando de regulación de llama Bouton	
26	01-LTL-4-23-245 -SS4	1	Side burner Quemador lateral Bruleur d'appoint	
27	ELJYP034B-RGC -DS2	1	Crease tray Bandeja de recogida de grasa Lèche-frite	
28	07-GGL-38-SI	1	Grease cup holder Soporte de la taza de grasa Graisser le porte-gobelet	
29	ELYB02-LS4	1	Grease cup Depósito de recogida de grasa Bac à graisse	

No.	#	QYT / CANT. / QTÉ	Description / Descripción / Description	Image / Imagen / Image
30	EJLTGDPL-RGC	1	Main body cart joint (L) Junta del carro del cuerpo principal (I) Joint de chariot du corps principal (G)	
31	EJLTGDPR-RGC	1	Main body cart joint (R) Junta del carro del cuerpo principal (D) Joint de chariot du corps principal (D)	
32	ELFHB04H-RGC -SS4	1	Flame tamer (big) Regulador de llama (grande) Gros atténuateur de flamme	
33	ELFHB05-RGC	4	Flame tamer Regulador de llama Atténuateur de flamme	
34	03-ZTW-E-01 -TC4	3	Cooking grate Rejilla para asar Grille de cuisson	
35	ELBWW014B -SS4	1	Warming rack Rejilla para calentar Grille de réchauffement	
36	06-WDJ-3-03	1	Thermometer Termómetro Thermomètre	

No.	#	Image / Imagen / Image	No.	#	Image / Imagen / Image
A	M5x10	 x56	H	Stud with nut Espárrago con tuerca integrada Goujon avec écrou	 x4
B	Washer Arandela Rondelle	 x4	I	Washer Arandela Rondelle	 x1
C	M4x10	 x4	J	M5	 x3
D	M5x12	 x10	K	M4x8	 x6
E	Magnet Imán Aimant	 x1	L	Washer Arandela Rondelle	 x8
F	M6x15	 x22	M	M5x12	 x3
G	M5x5	 x3			

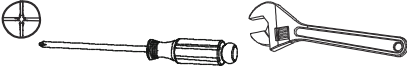
TOOLS REQUIRED / HERRAMIENTAS REQUERIDAS / OUTILS REQUIS		
Description / Descripción / Description		Image / Imagen / Image
Phillips screwdriver Destornillador phillips Tournevis phillips	Wrench Llave Clé	

Before beginning assembly, make sure all parts are present. If any parts are missing or damaged, do not attempt to assemble the products. Contact customer service for replacement parts via telephone or email.

- Tools needed (not included): Phillips screwdriver and wrench
- Approximate assembly time: 70 minutes
- Note: 1. The right and left sides of the grill are designed as if you are facing the front of the grill.  
2. Model shown for illustration purpose only, specific please in kind prevail.

---

Antes de comenzar el montaje, asegúrese de que todas las piezas estén presentes. Si falta alguna pieza o está dañada, no intente ensamblar los productos. Póngase en contacto con el servicio de atención al cliente para obtener piezas de repuesto por teléfono o correo electrónico.

- Herramienta necesaria (no incluido): Destornillador phillips y llave
- Tiempo aproximado de ensamblaje: 70 minutos
- Nota: 1. Los lados derecho e izquierdo de la parrilla están diseñados como si estuvieras frente a la parte delantera de la parrilla.  
2. El modelo que se muestra es sólo para fines ilustrativos, prevalecen los específicos en especie.

---

Avant de commencer l'assemblage, assurez-vous que toutes les pièces sont présentes. Si des pièces sont manquantes ou endommagées, n'essayez pas d'assembler les produits. Contactez le service de clientèle pour les pièces de rechange par téléphone ou par e-mail.

- Outils nécessaires (non inclus): Tournevis phillips et clé
- Temps nécessaire pour l'assemblage: 70 minutes
- Remarque: 1. Les côtés droit et gauche du gril sont conçus comme si vous faisiez face à l'avant du gril.  
2. Le modèle est présenté à des fins d'illustration uniquement, spécifiques en nature prévalent.

1 F   x2

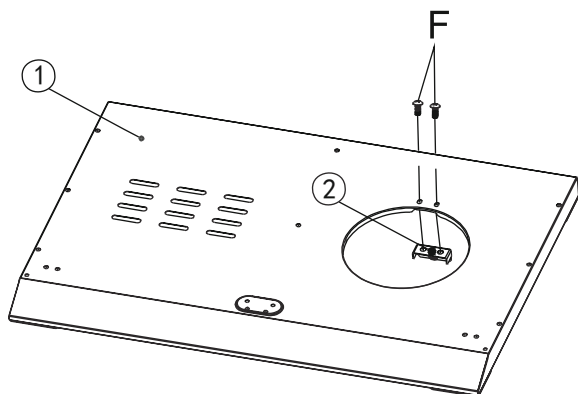

2

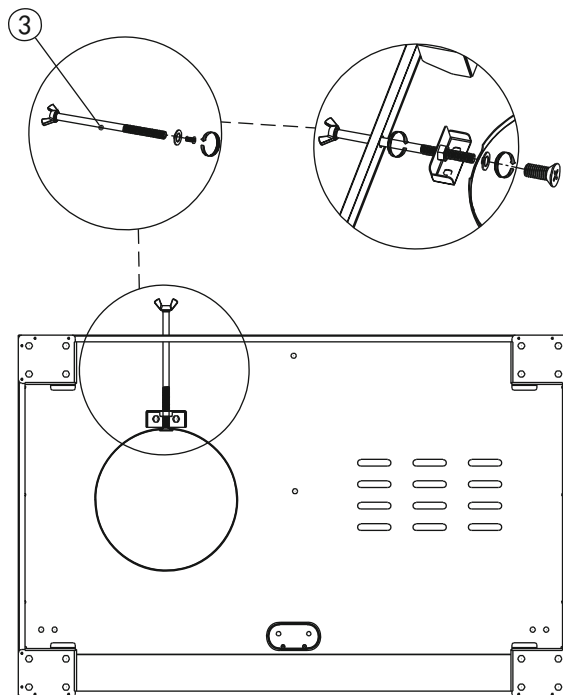

3 F   x16

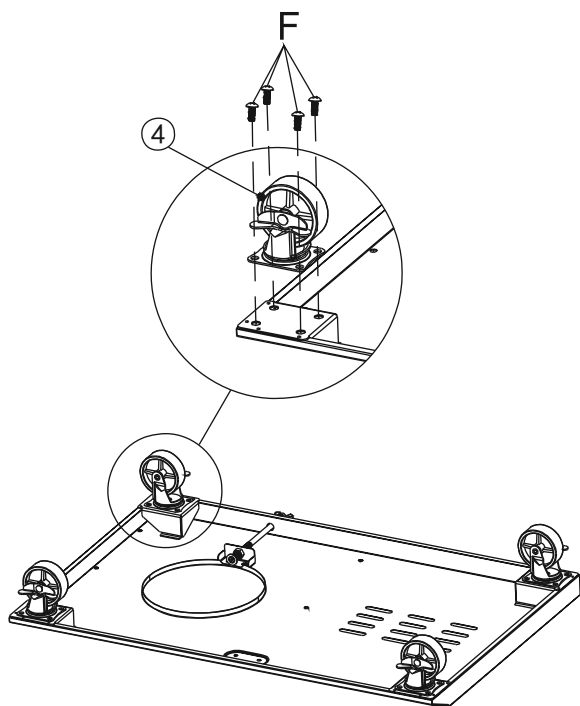

4 A   x4

- Do not secure the bolts until step 6.
- No apretar las tornillos hasta el paso 6.
- Ne pas fixez les boulons avant l'étape 6.

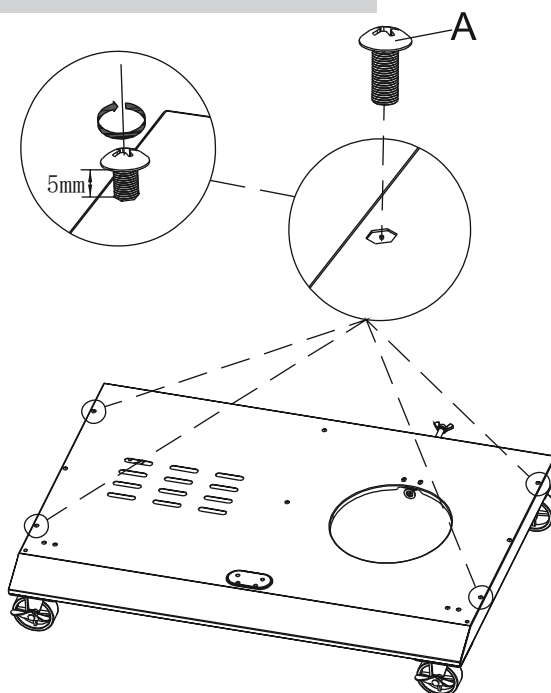

5

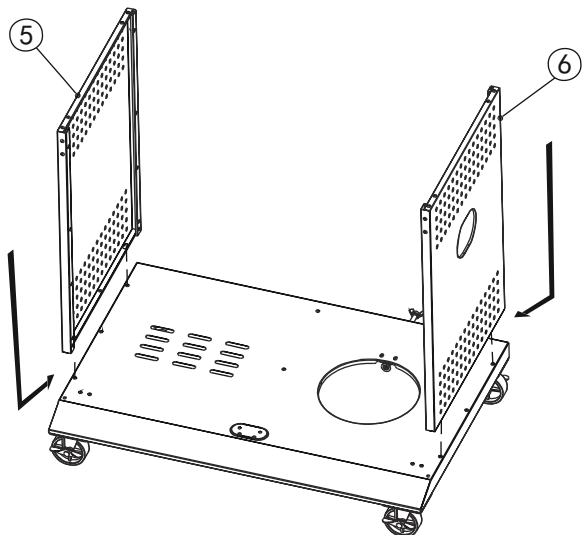

6

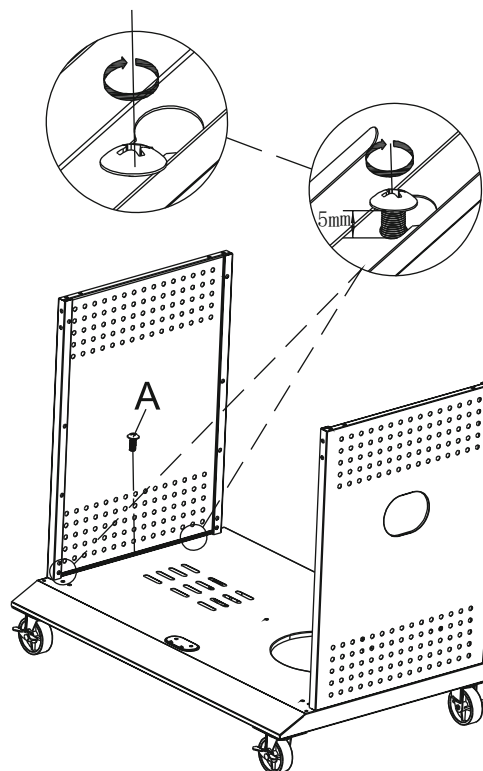
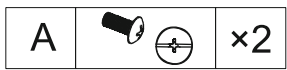

7

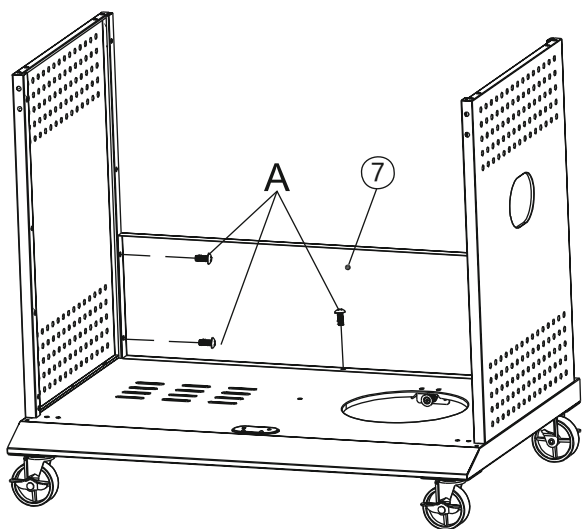

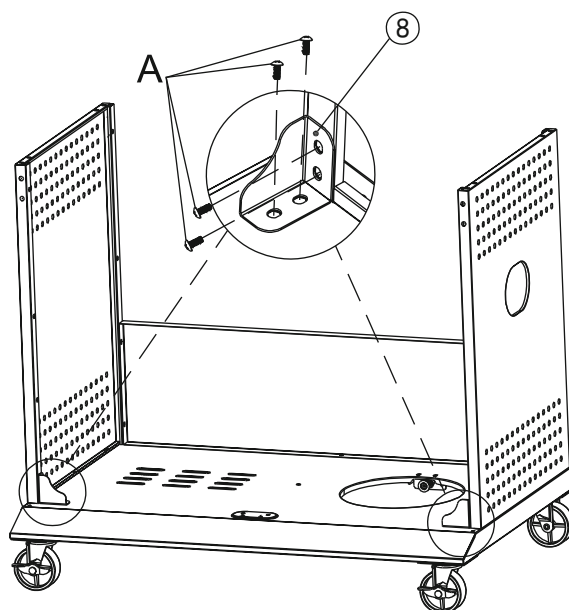

8



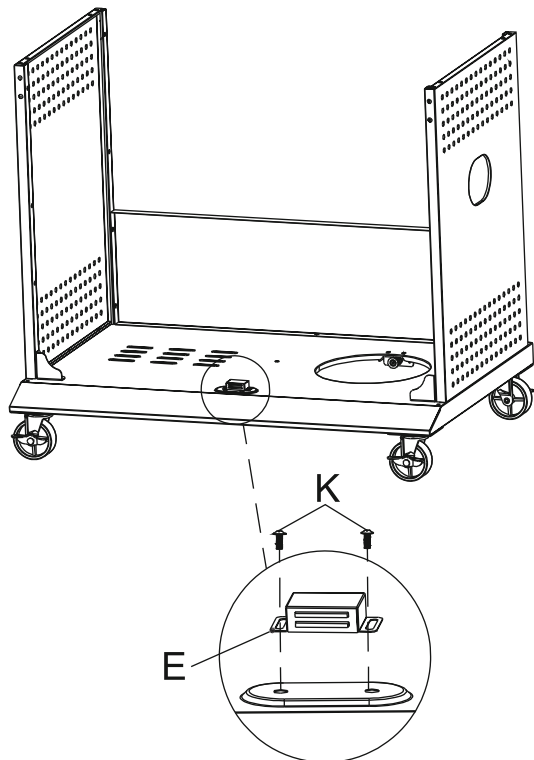

- 9** K  x2 E  x1

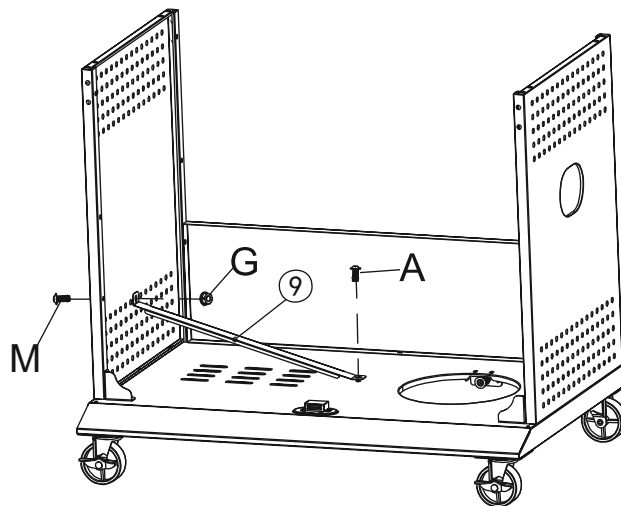

- 10** A  x1 G  x1  
M  x1



- 11** A  x2 D  x6

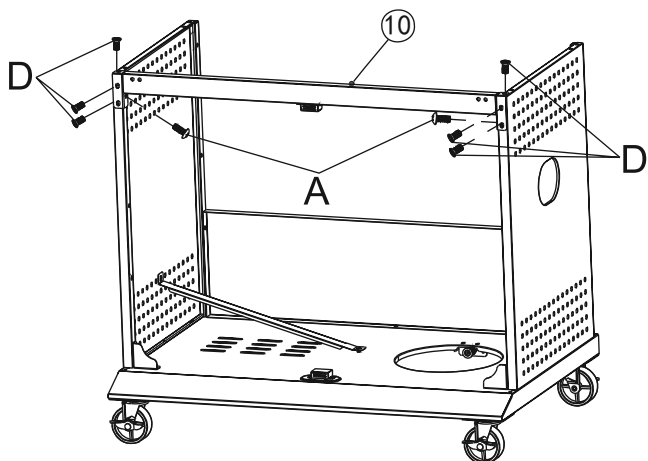

- 12** A  x2

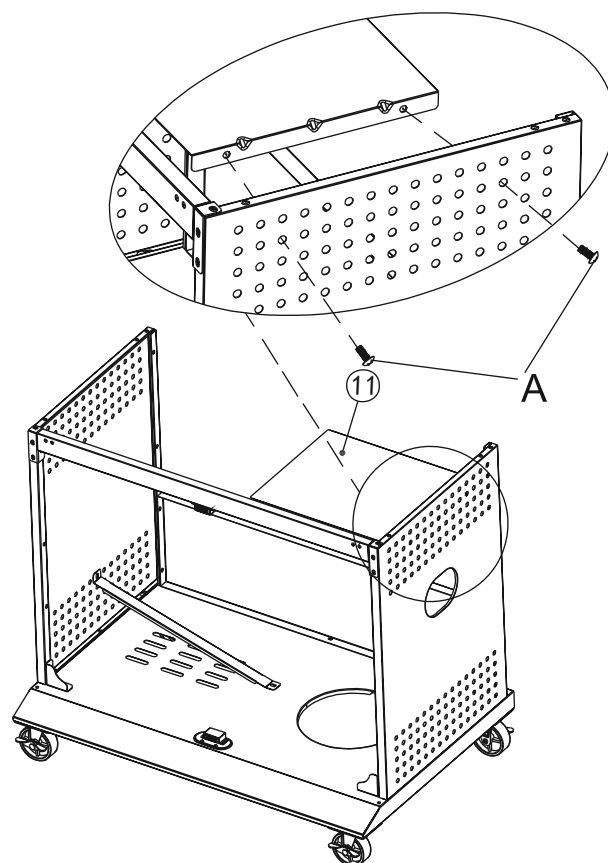

13 D  x4

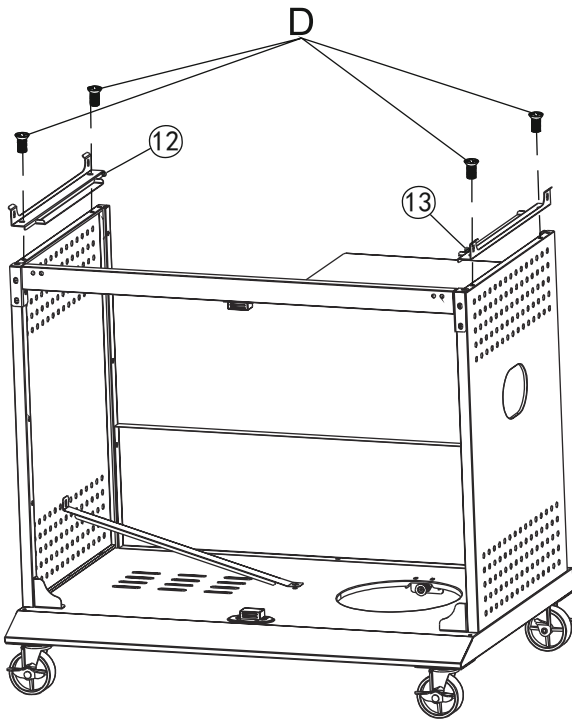

14 H  x4

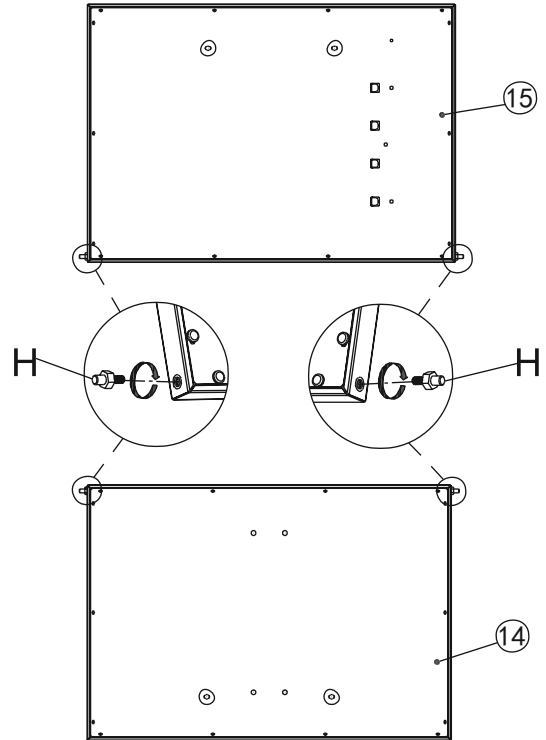

15

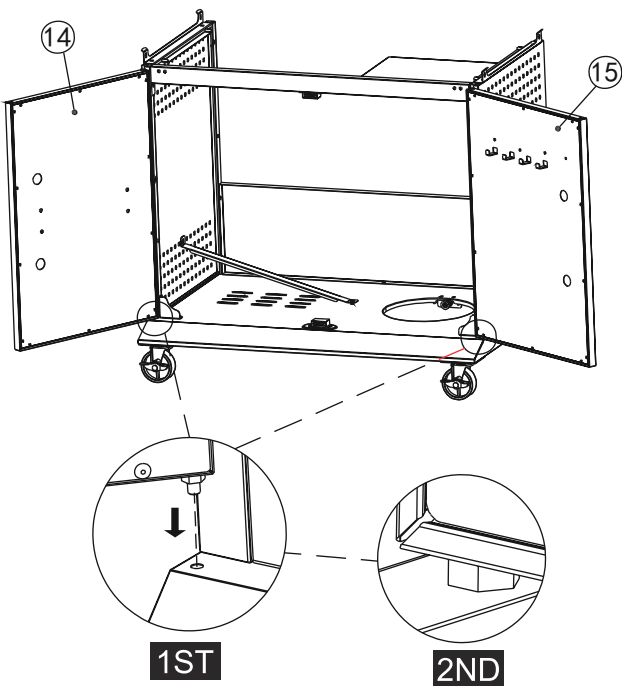

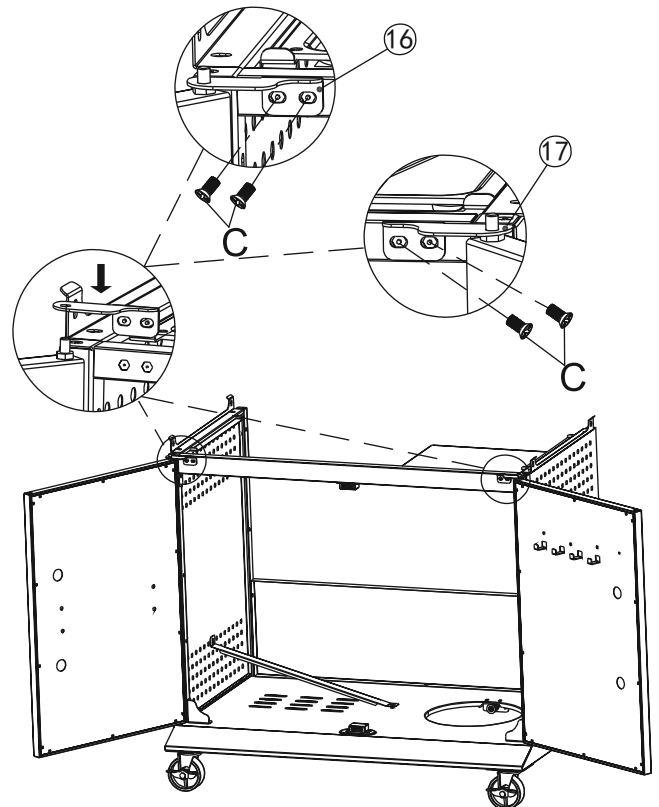

16 C  x4

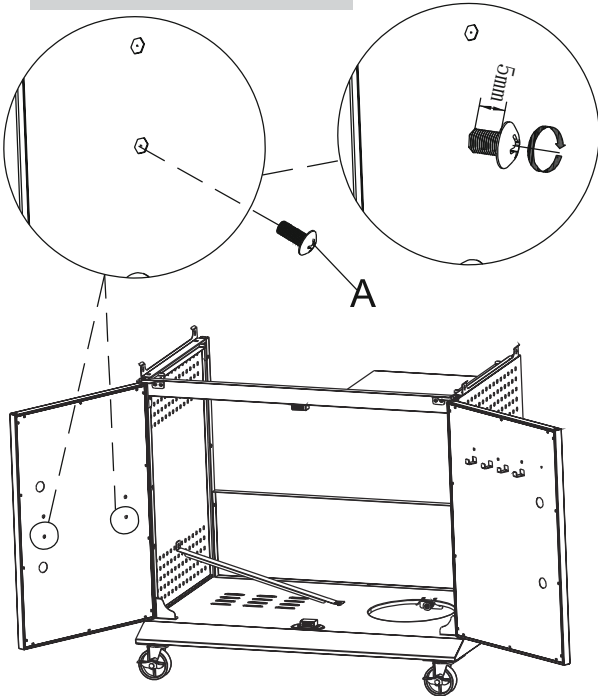

**17** A  ×2

- Do not secure the bolts until step 18.
- No apretar las tornillos hasta el paso 18.
- Ne pas fixez les boulons avant l'étape 18.



**18** A  ×2

**2ND**

- Secure
- Asegure
- Fixez

**1ST**

- Secure
- Asegure
- Fixez

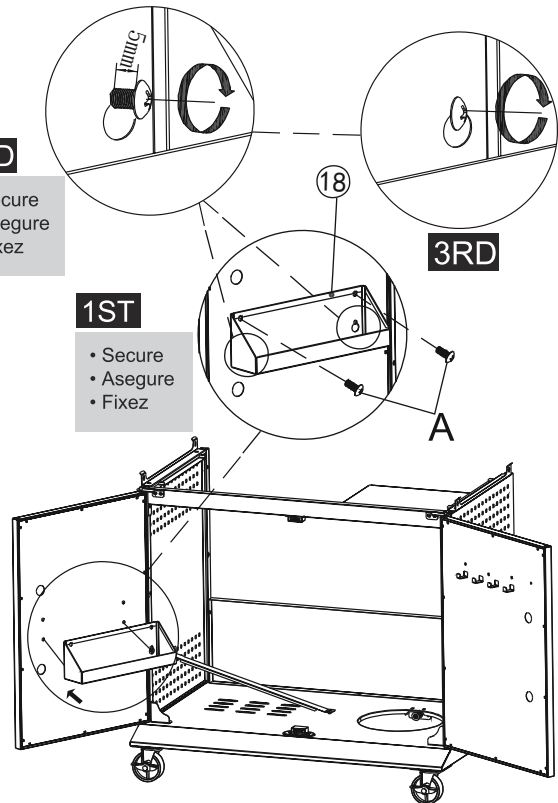

**19** B  ×4 F  ×4

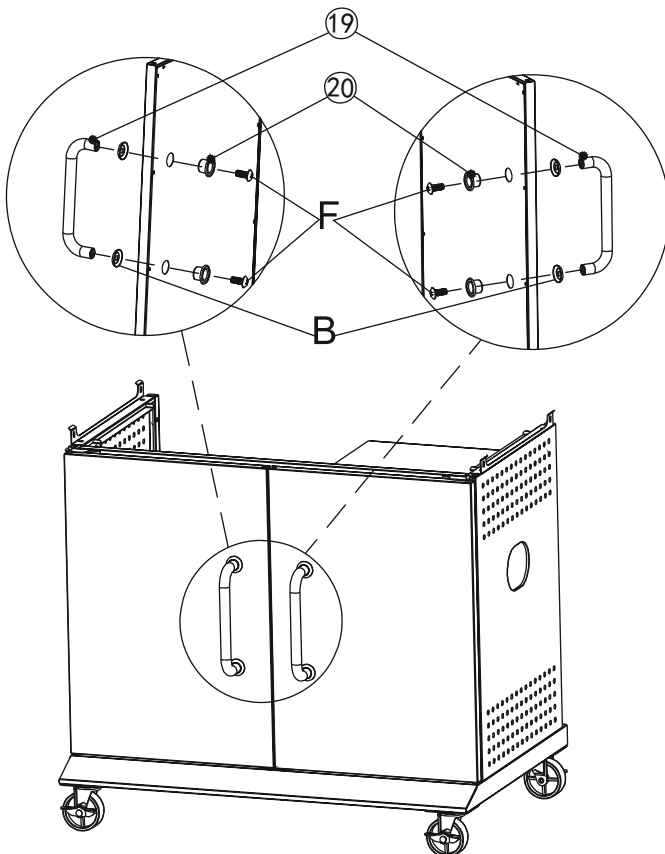

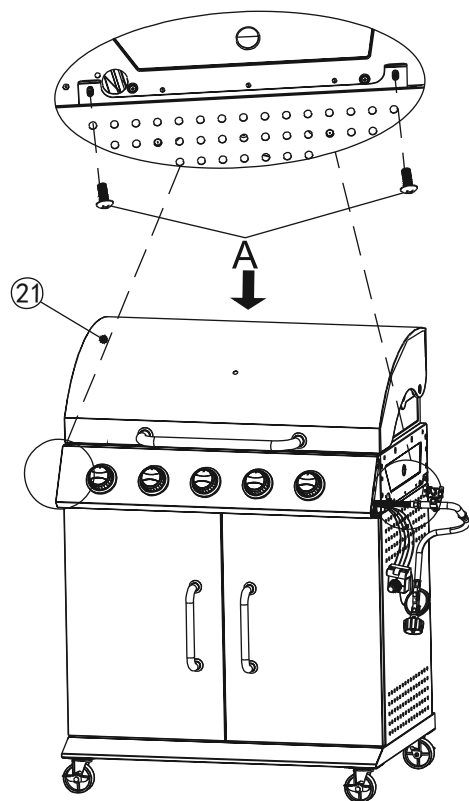

**20** A  ×4

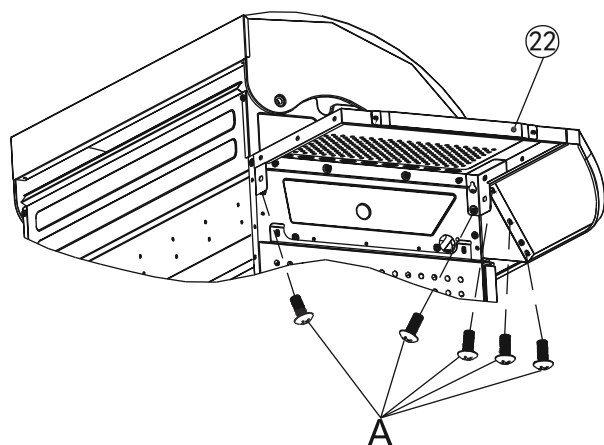

21 A   x5





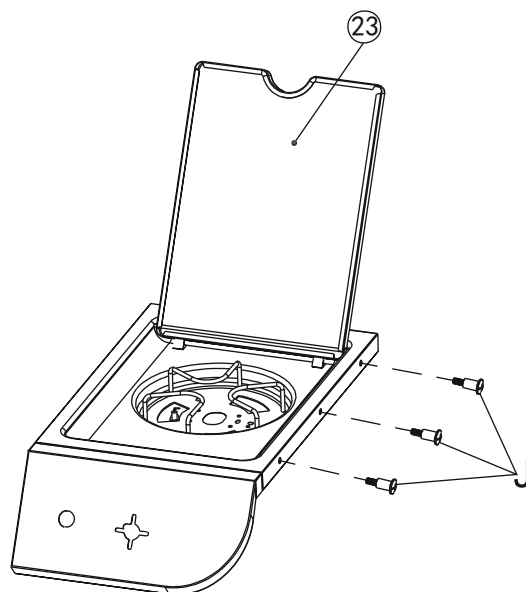

22 J   x3

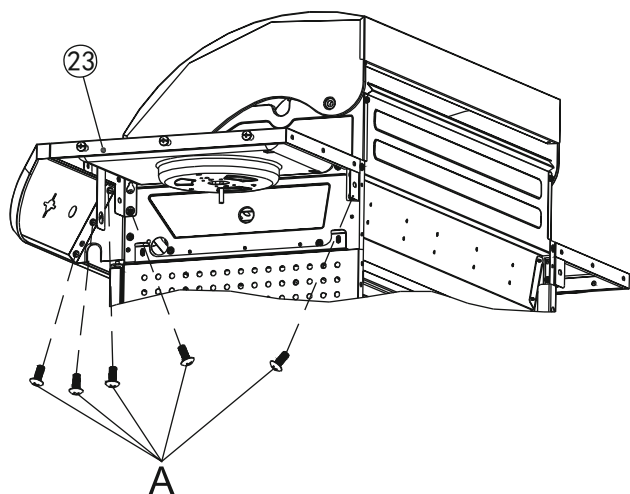

23 A   x5



24 A   x8 L   x8

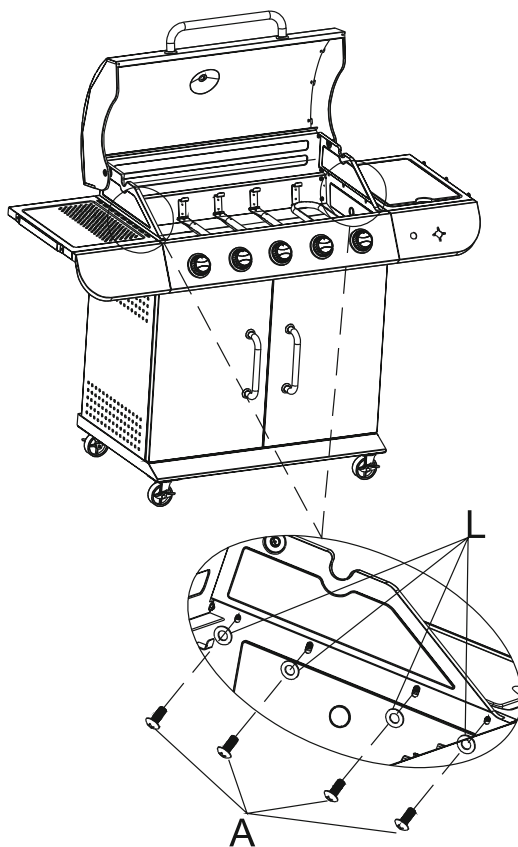

25

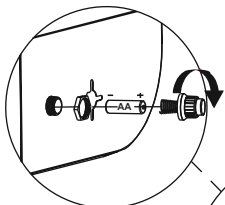
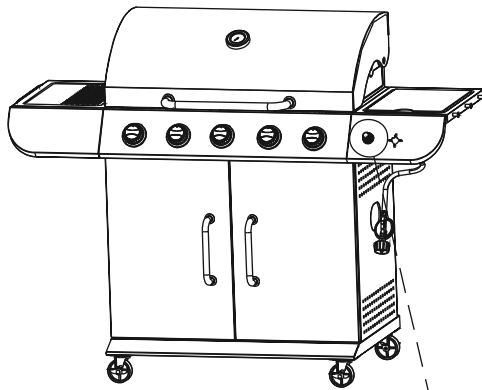

3RD

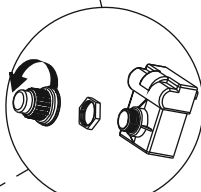

1ST

- AA battery not included.
- Pila AA no incluida.
- Pile AA non incluse.

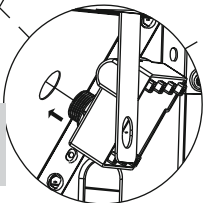

2ND

26

K  ×2

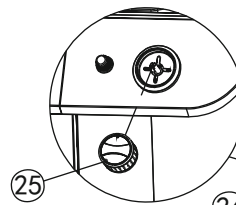
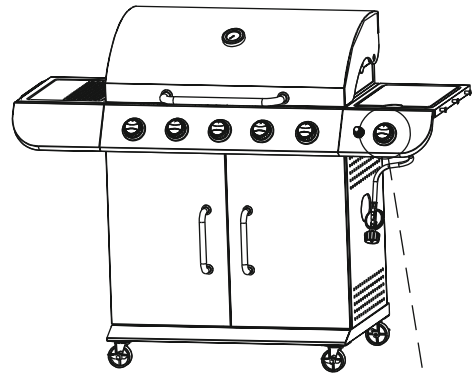

3RD

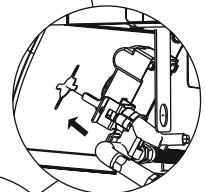

1ST

- Side burner valve
- Válvula de quemador lateral
- Vanne du brûleur latéral

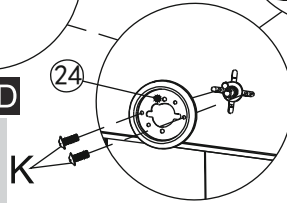

2ND

27

K  ×2

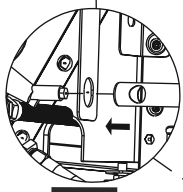
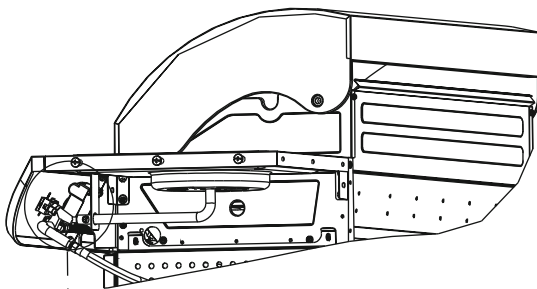

1ST



3RD

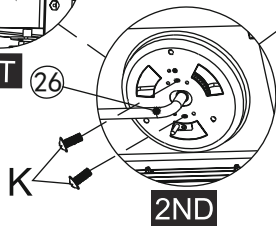

2ND

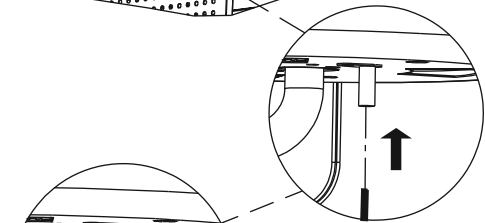
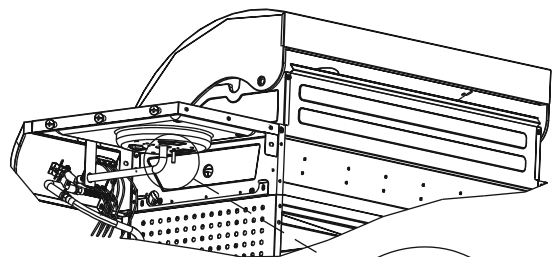

28

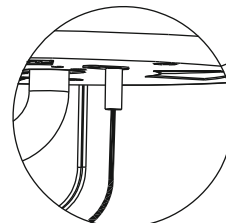

1ST



2ND

29 G  x2 M  x2

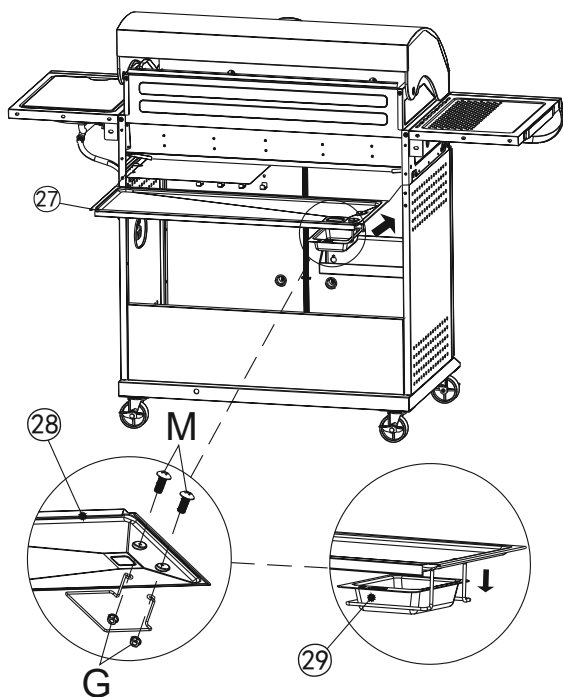

30 A  x6

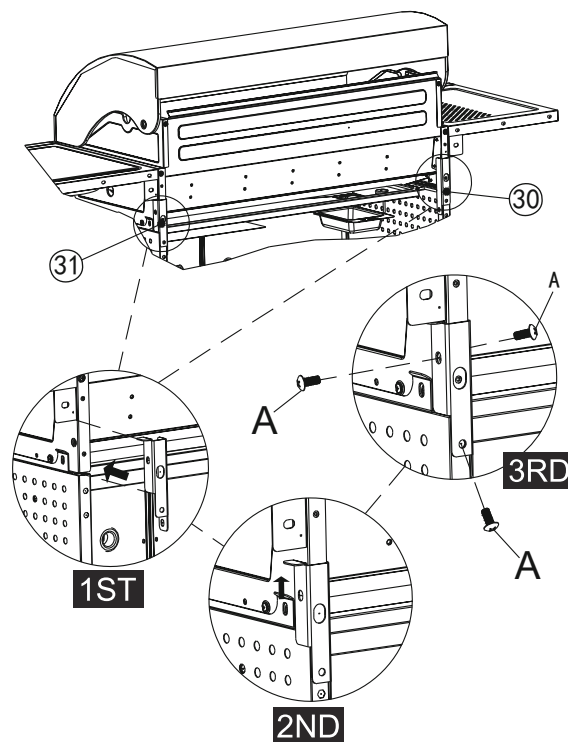

31

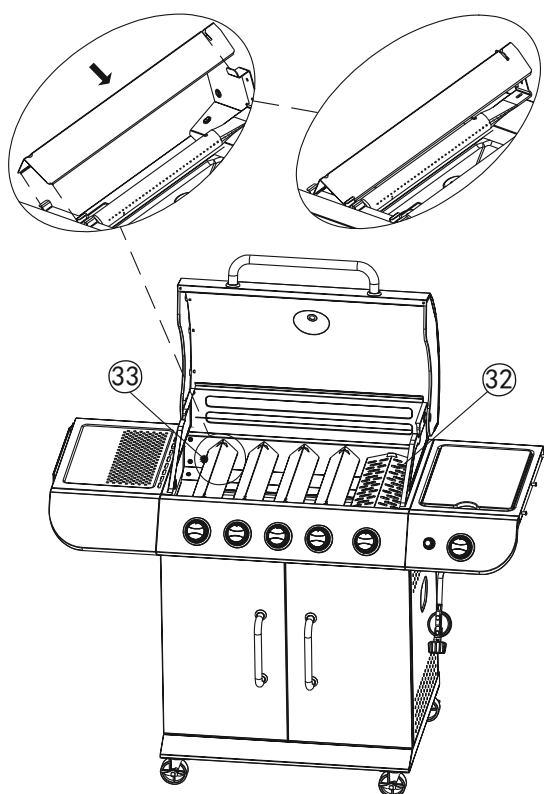

32

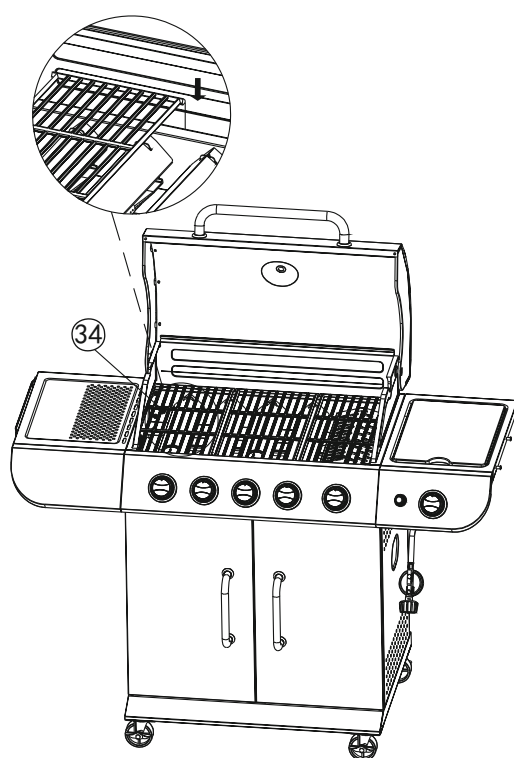

33

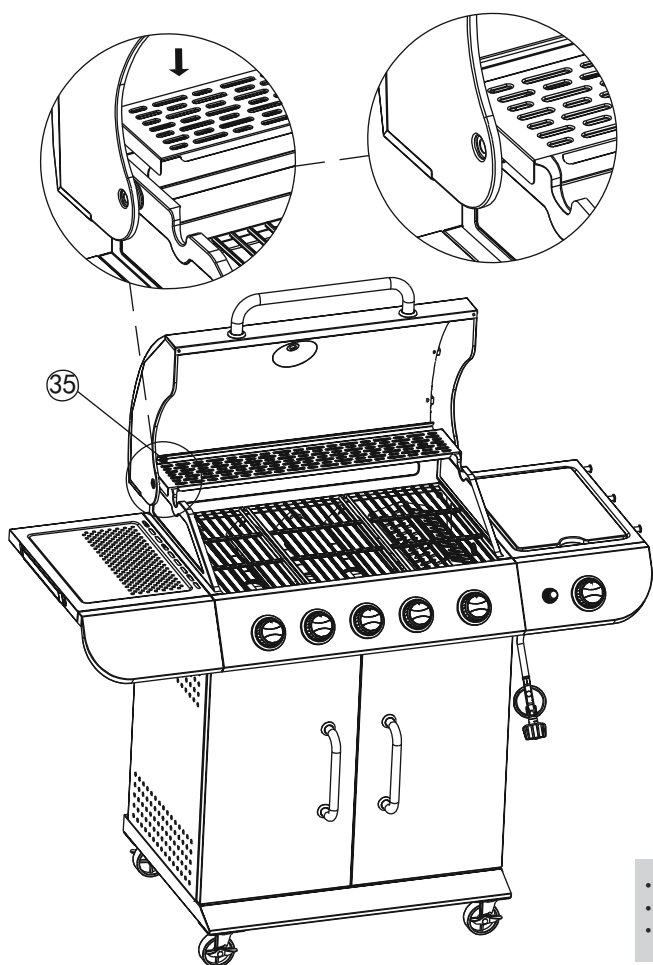

34

	⊙	⊙	×1
--	---	---	----

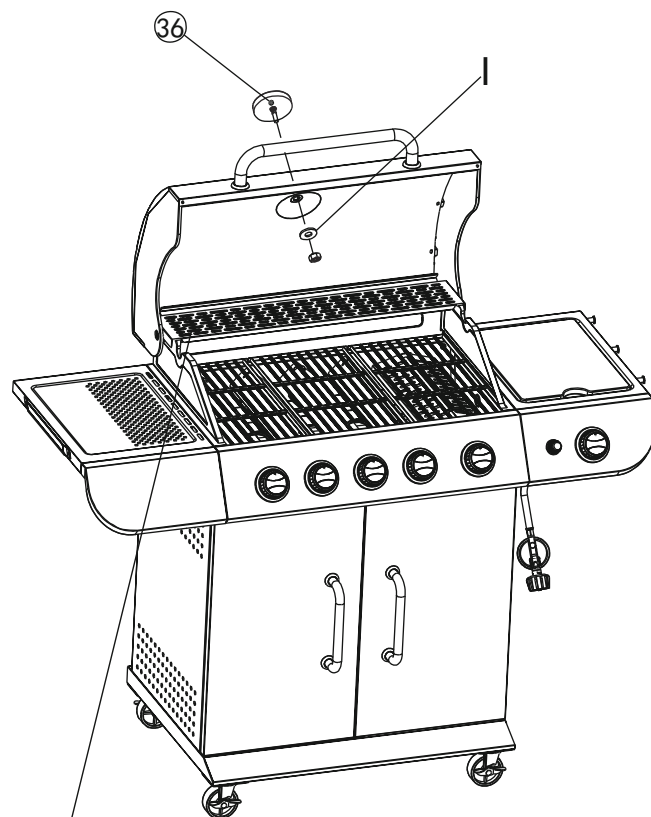

- Remove protective film from stainless steel warming rack before using.
- Retire la película protectora de la rejilla para calentarde acero inoxidable antes de usar.
- Retirez le film protecteur de la grille de réchauffement en acier inoxydable avant utilisation.

**Thank You  
For Choosing Us.**

**Any Problem!  
We Can Help!**

**Customer  
Service**

**1-800-618-6798**

**Monday to Friday ( 8:30 am - 5:00 pm EST )**

**[service@royalgourmetusa.com](mailto:service@royalgourmetusa.com)**