

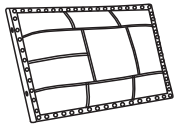









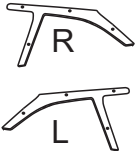

ASSEMBLY INSTRUCTIONS

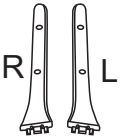
<p>Ax1</p> 	<p>Gx2</p> 
<p>Bx1</p> 	<p>Hx5</p>  <p>M6*50mm</p>
<p>Cx1(R&L)</p> 	<p>Ix9</p>  <p>M8*40mm</p>
<p>Dx1(R&L)</p> 	<p>Jx5</p>  <p>M8*60mm</p>
<p>Ex2</p> 	<p>Kx1</p> 
<p>Fx2</p> 	<p>Lx1</p> 

STEP:1 Assemble the left and right armrests
Connect Part(D) and Part (C) by tightening the screws(J) 80%

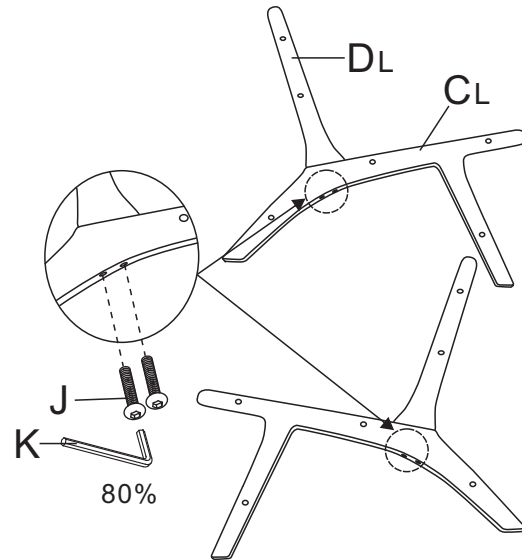

STEP:2 Connect Part(E) to the armrests
by tightening the screws(H) 80%

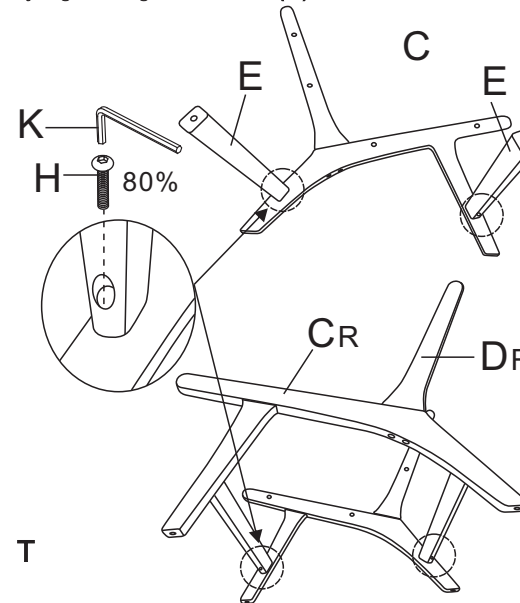

STEP:3 Connect the seat(B) to the armrests
by tightening the screws (I) 80%

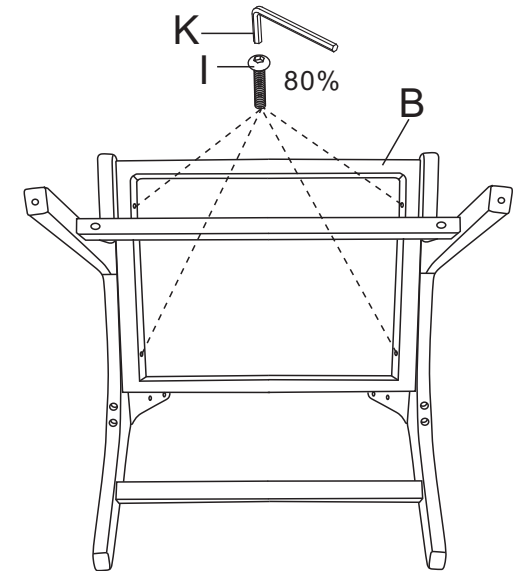

STEP:4 Assemble the backrest(A) to the
armrests by tightening the screws (I) 80%

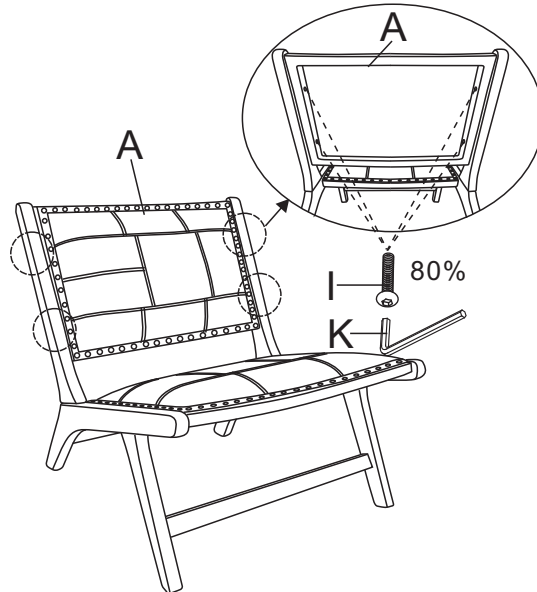

STEP:5 Tightening all the screws by 100%,
Put Part(G) and Part(F) to the bottom of the legs

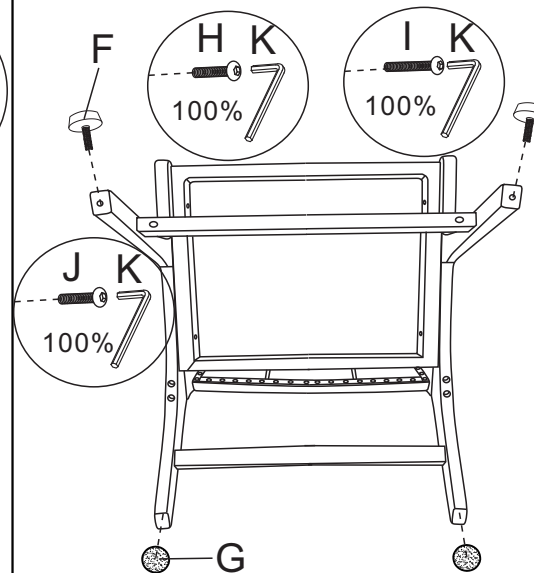

STEP:6

