

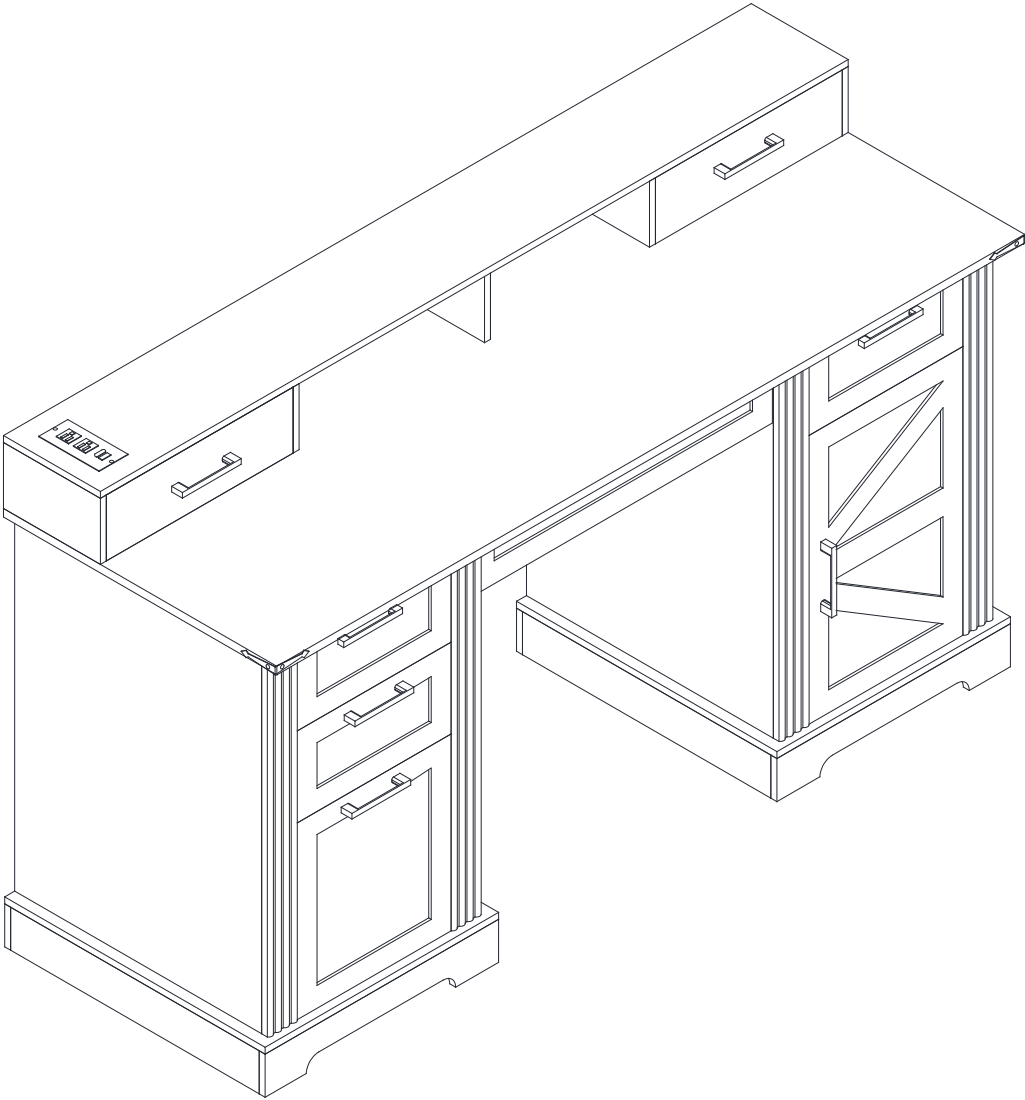

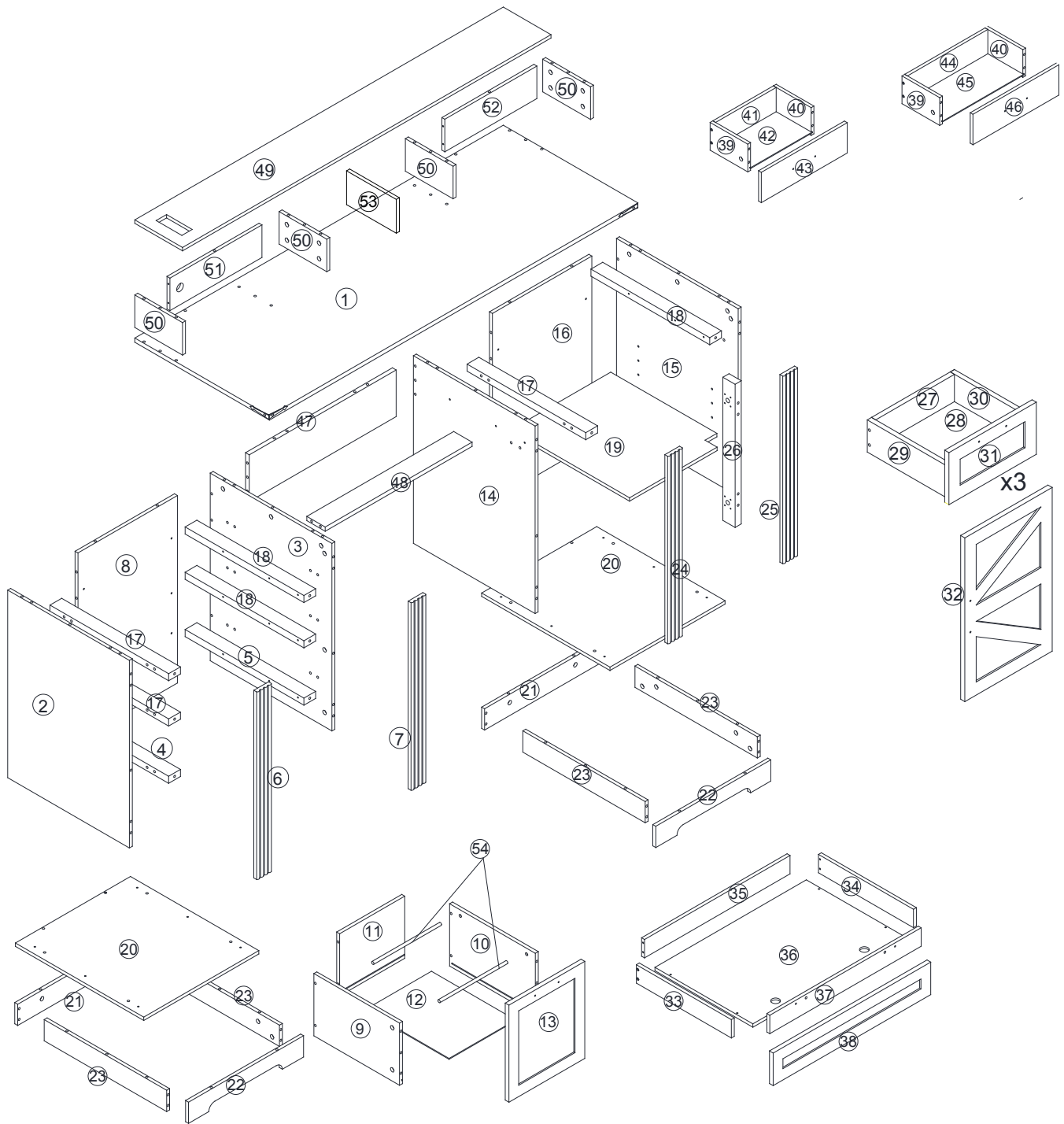







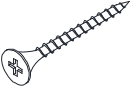
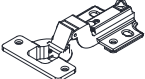

# ASSEMBLY INSTRUCTION



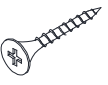
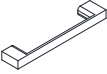
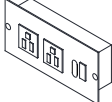

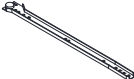
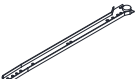
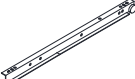
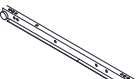
## Hardware List

 A x 130+2	 B x 130+2	 6x30 C x 104+2	 3.5x12 D x 60+2	 4x40 E x 52+2	 F x 2	 G x 2
 4x12 H x 22+2	 6x20 I x 2	 4x20 J x 3	 K x 7	 L x 1	 M x 4	 4x14 N x 14+1
 CL x 4	 CR x 4	 DL x 4	 DR x 4	 O x 2	 P x 2	

ASSEMBLY TOOLS REQUIRED(NOT INCLUDED)  
OUTILS DE MONTAGE NÉCESSAIRES (NON INCLUS)

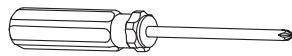



# STEP 1

A		24
---	---	----

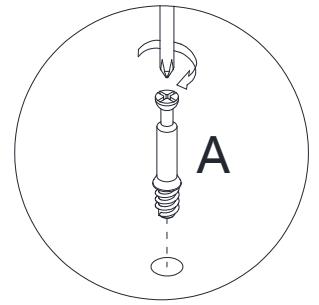
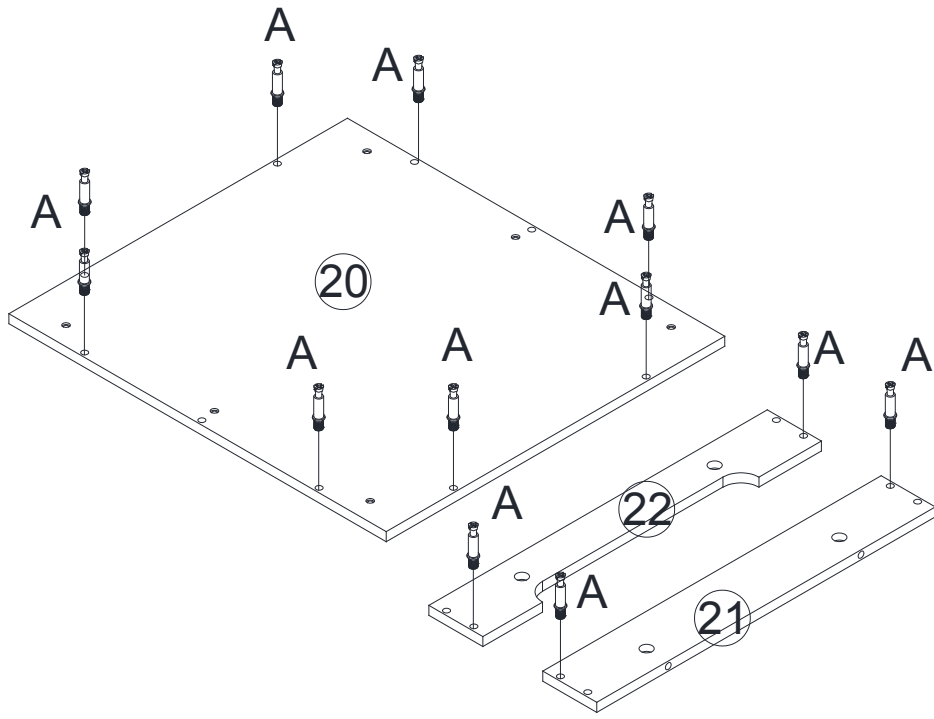
x2



# STEP 2

B		24
C		12

x2

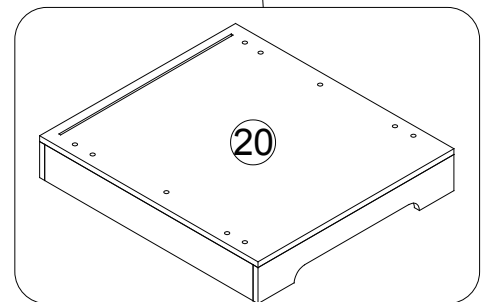
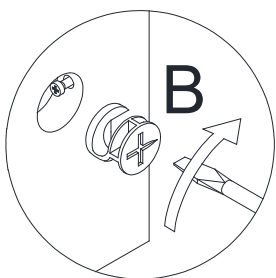
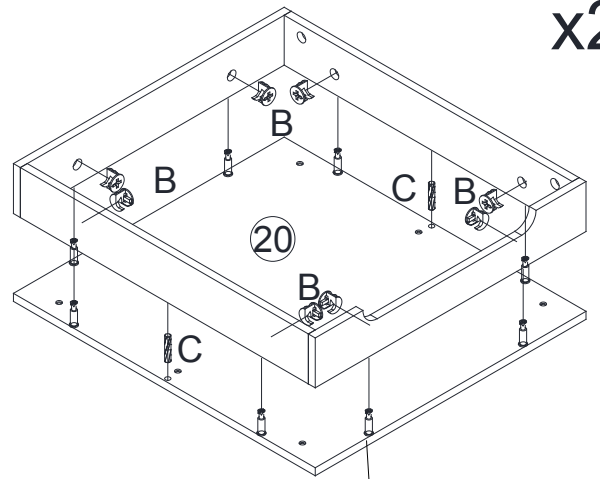
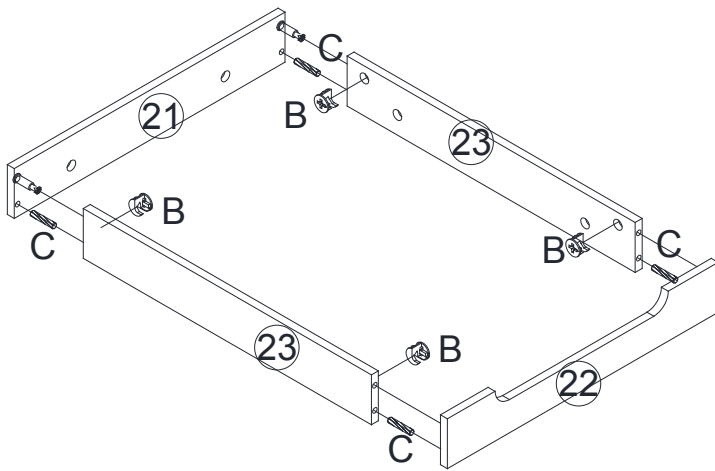

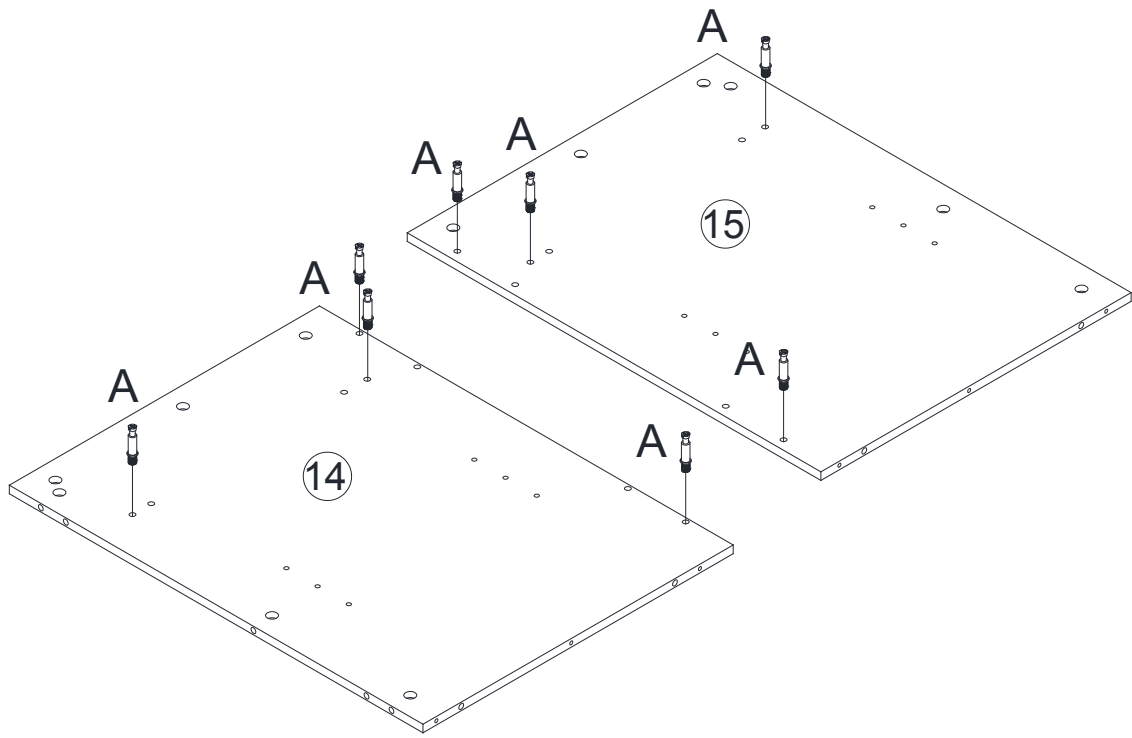

# STEP 3

A		8
---	---	---



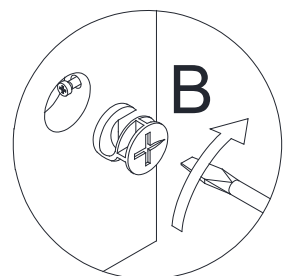
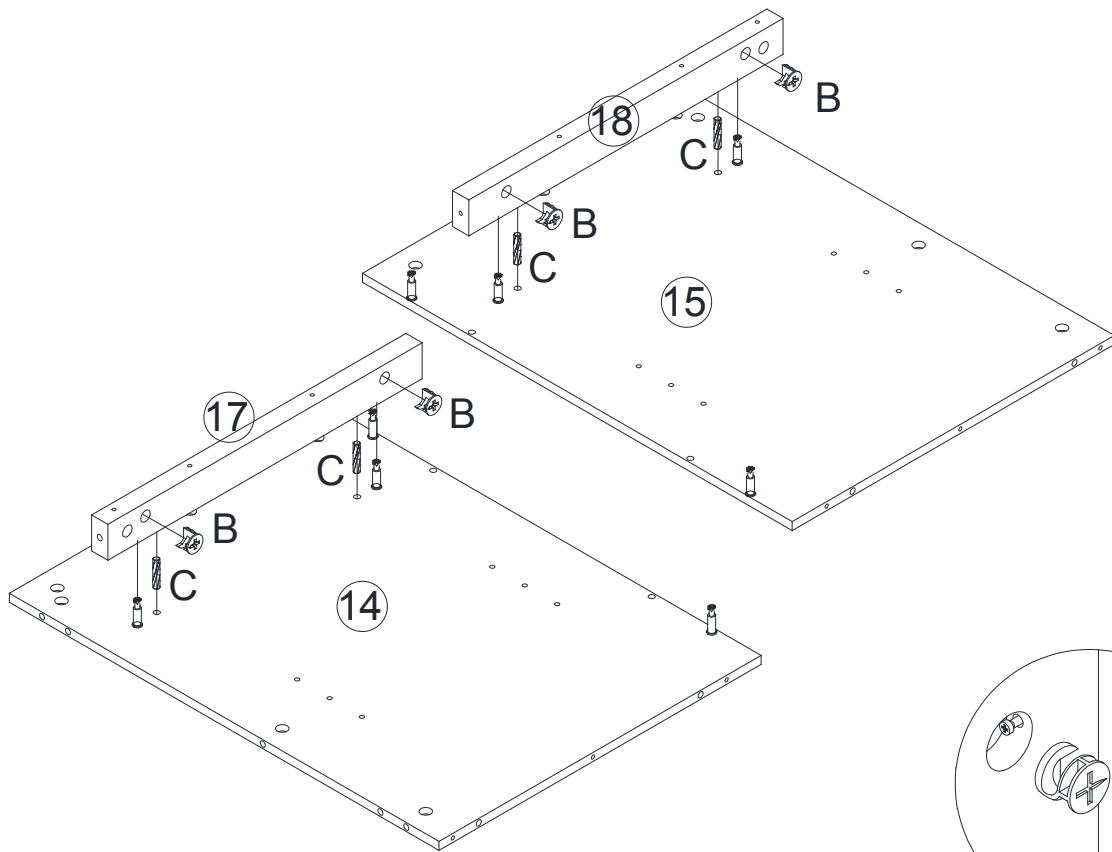

# STEP 4

B		4
C		4



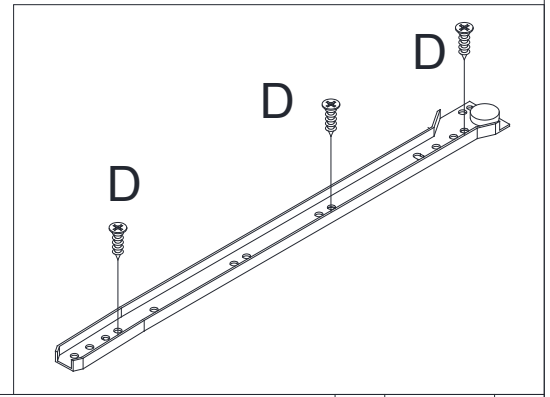
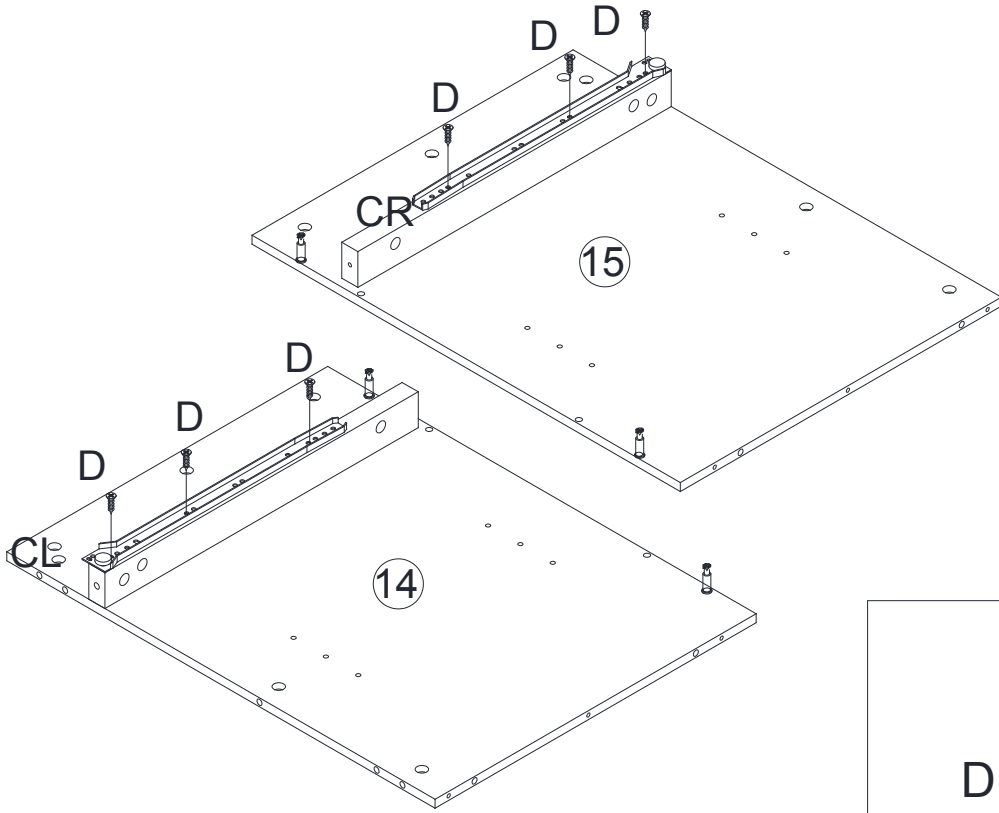

# STEP 5

D		6
CL		1
CR		1



# STEP 6

B		4
C		4

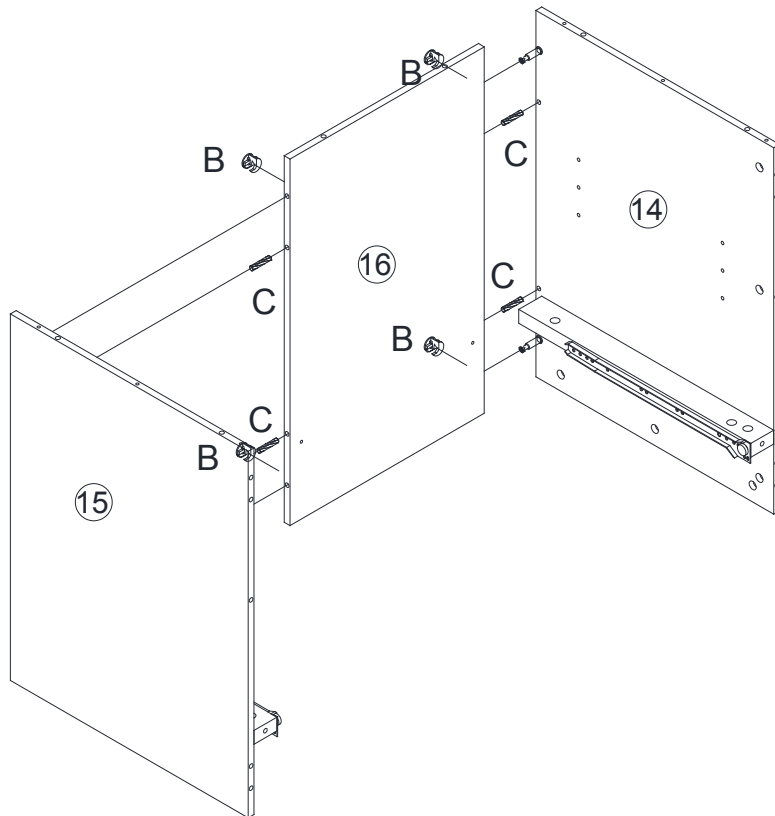

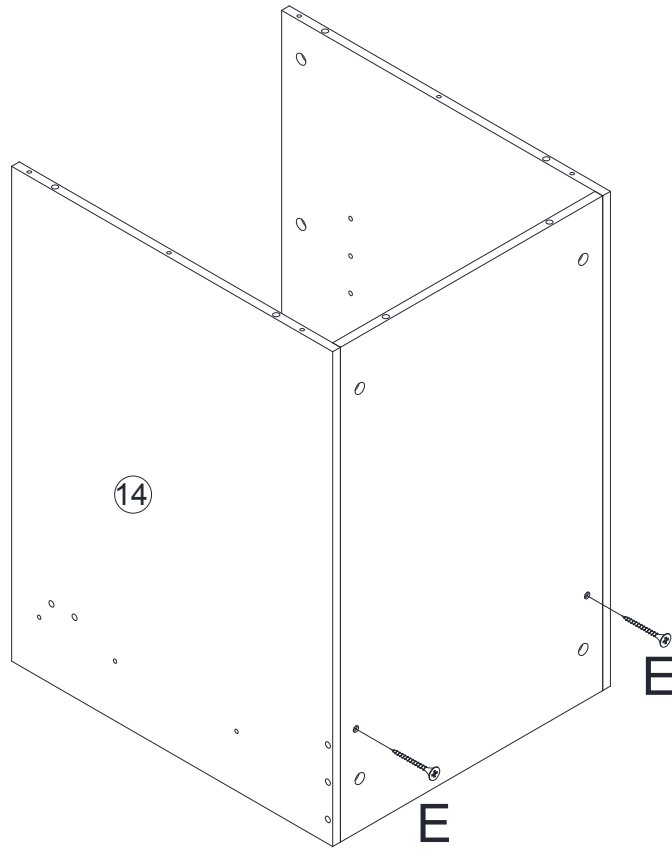

# STEP 7

E		2
---	---	---



# STEP 8

E		6
C		6

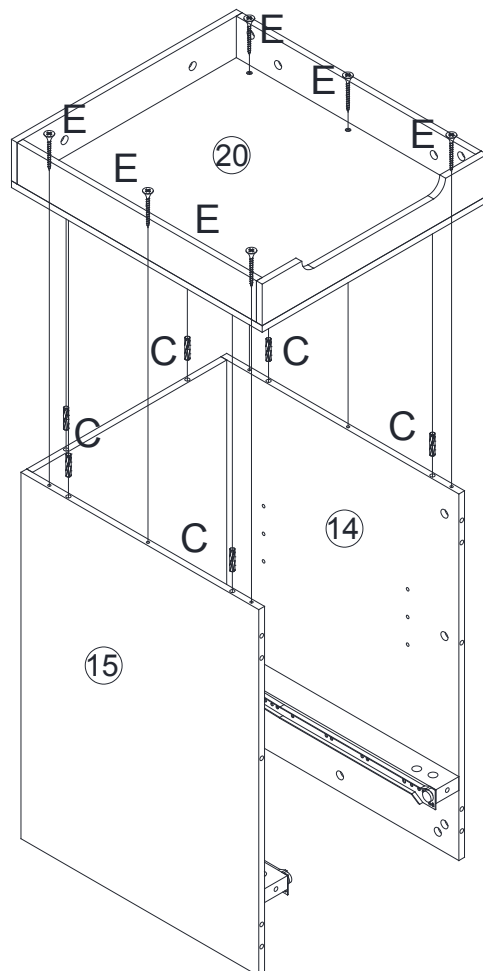

# STEP 9

A		22
---	---	----

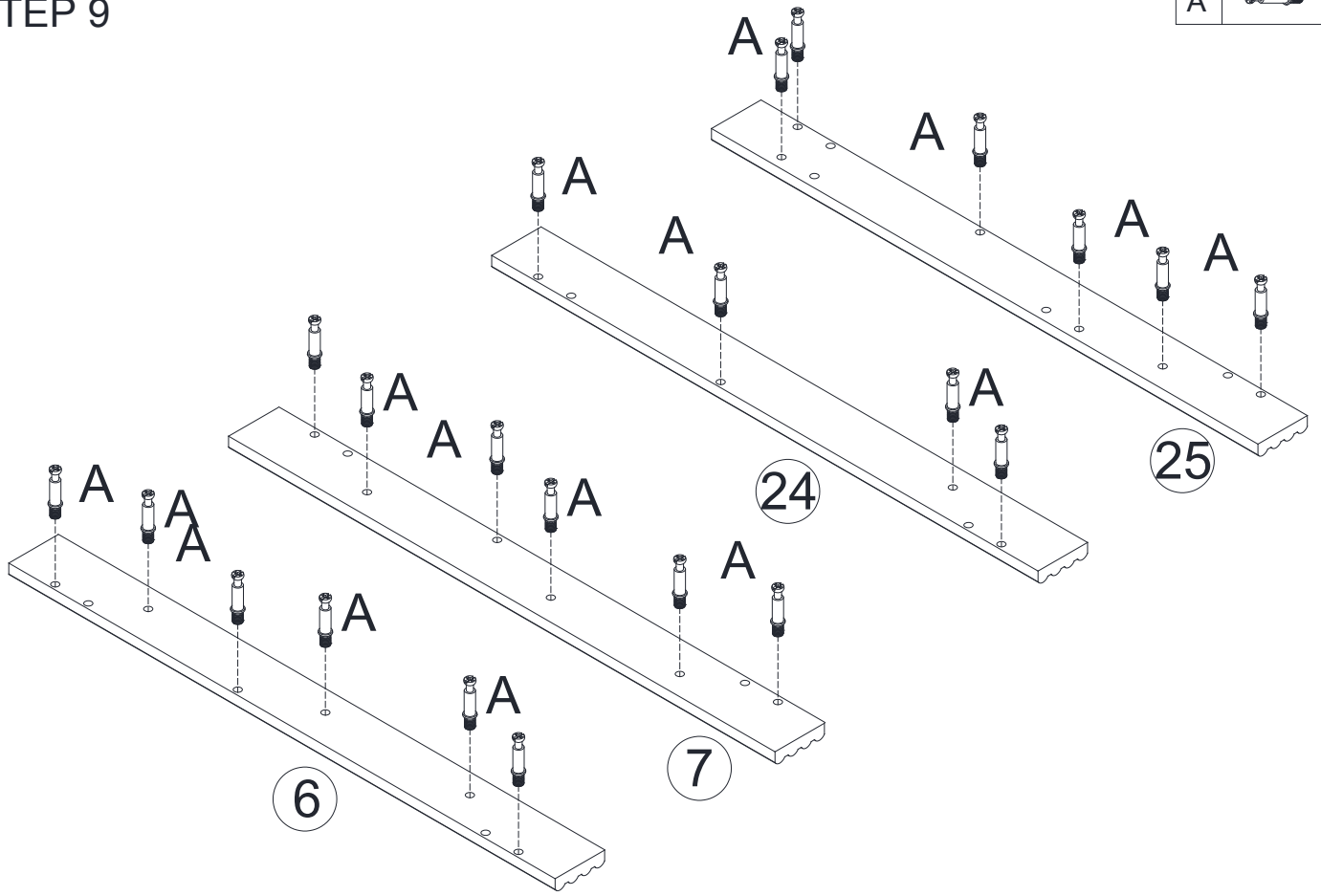

# STEP 10

B		10
C		6

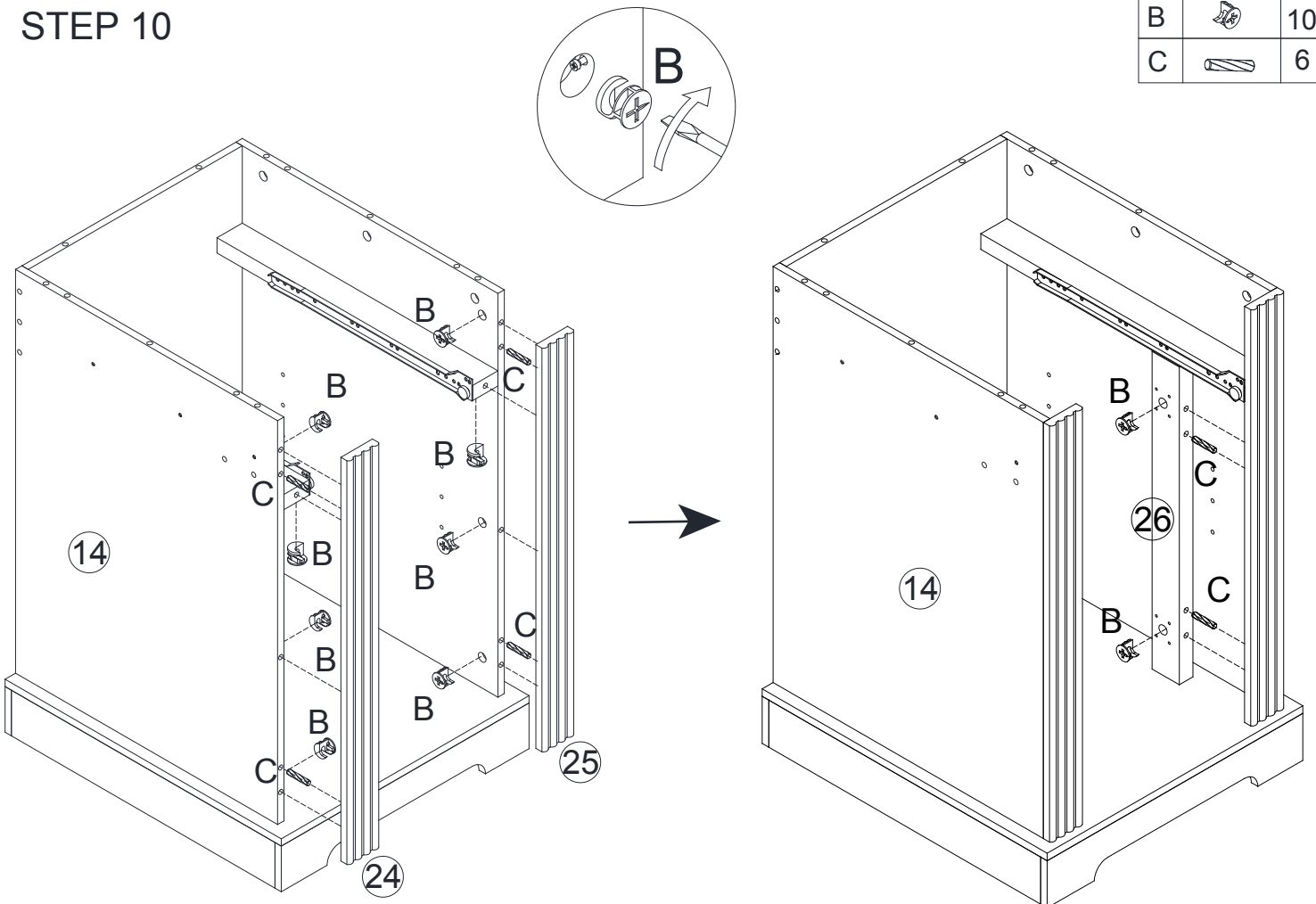

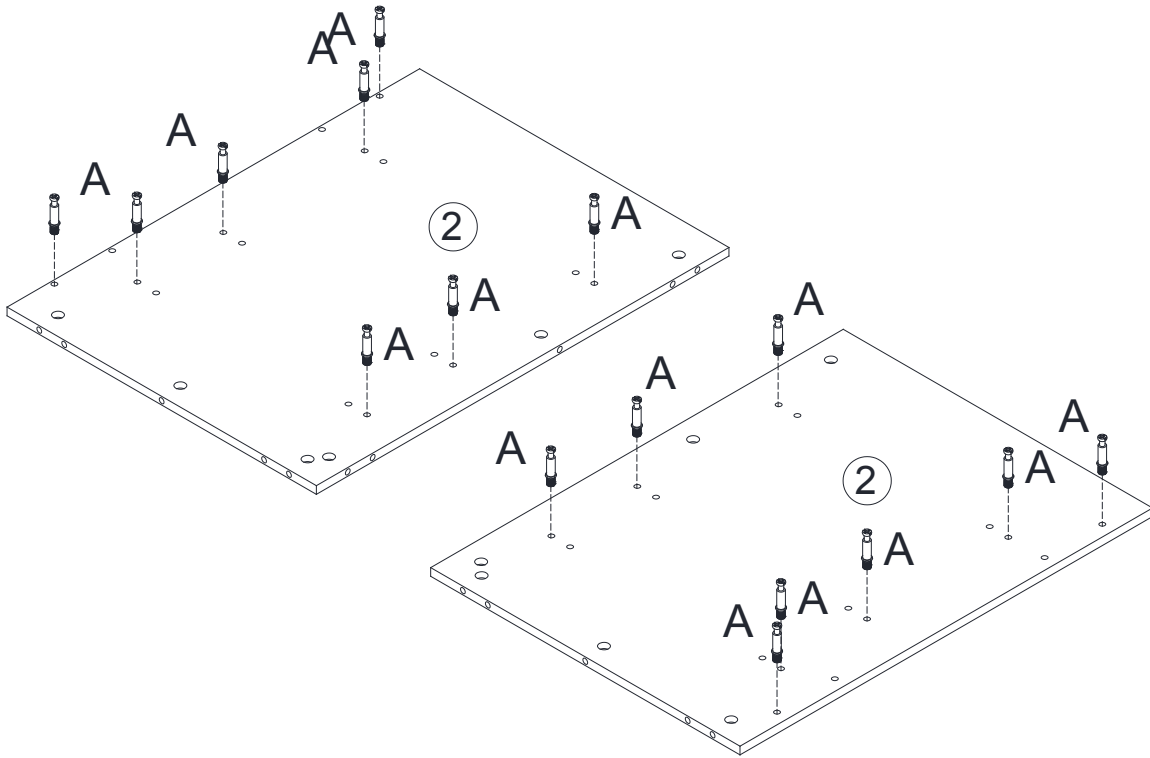

# STEP 11

A		16
---	---	----



# STEP 12

B		12
C		12

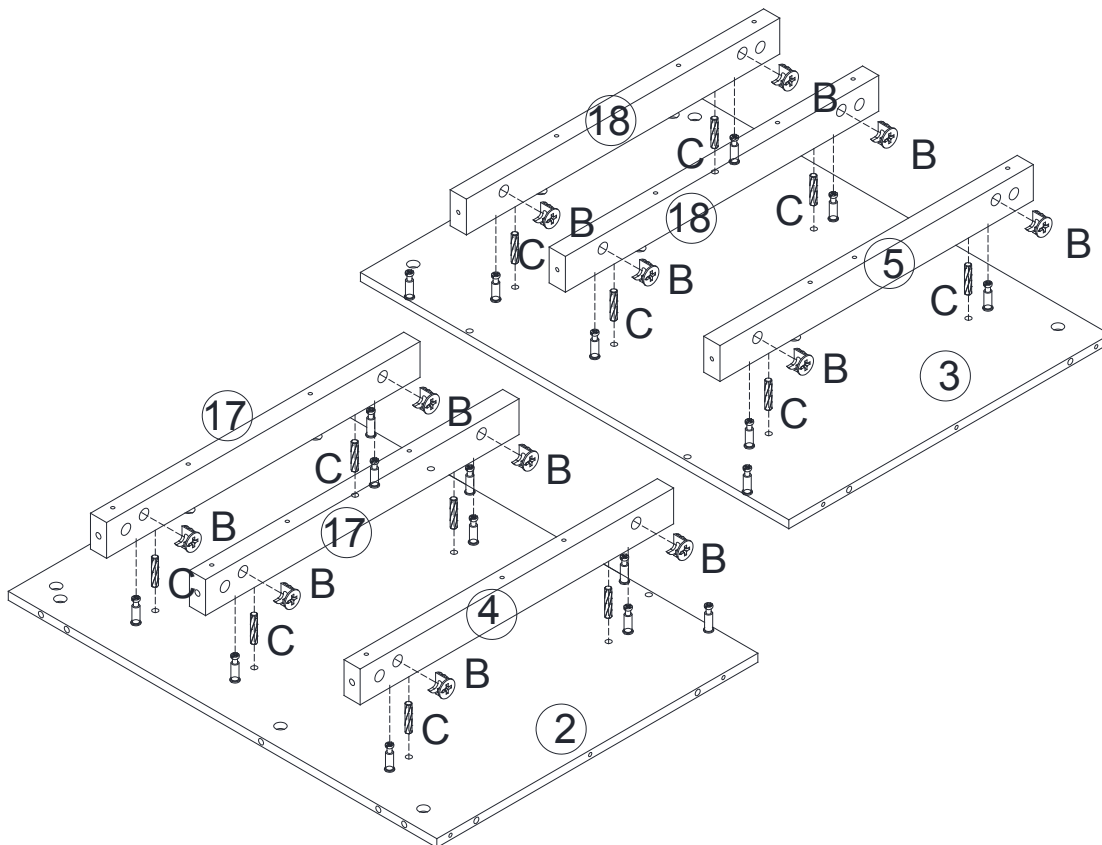



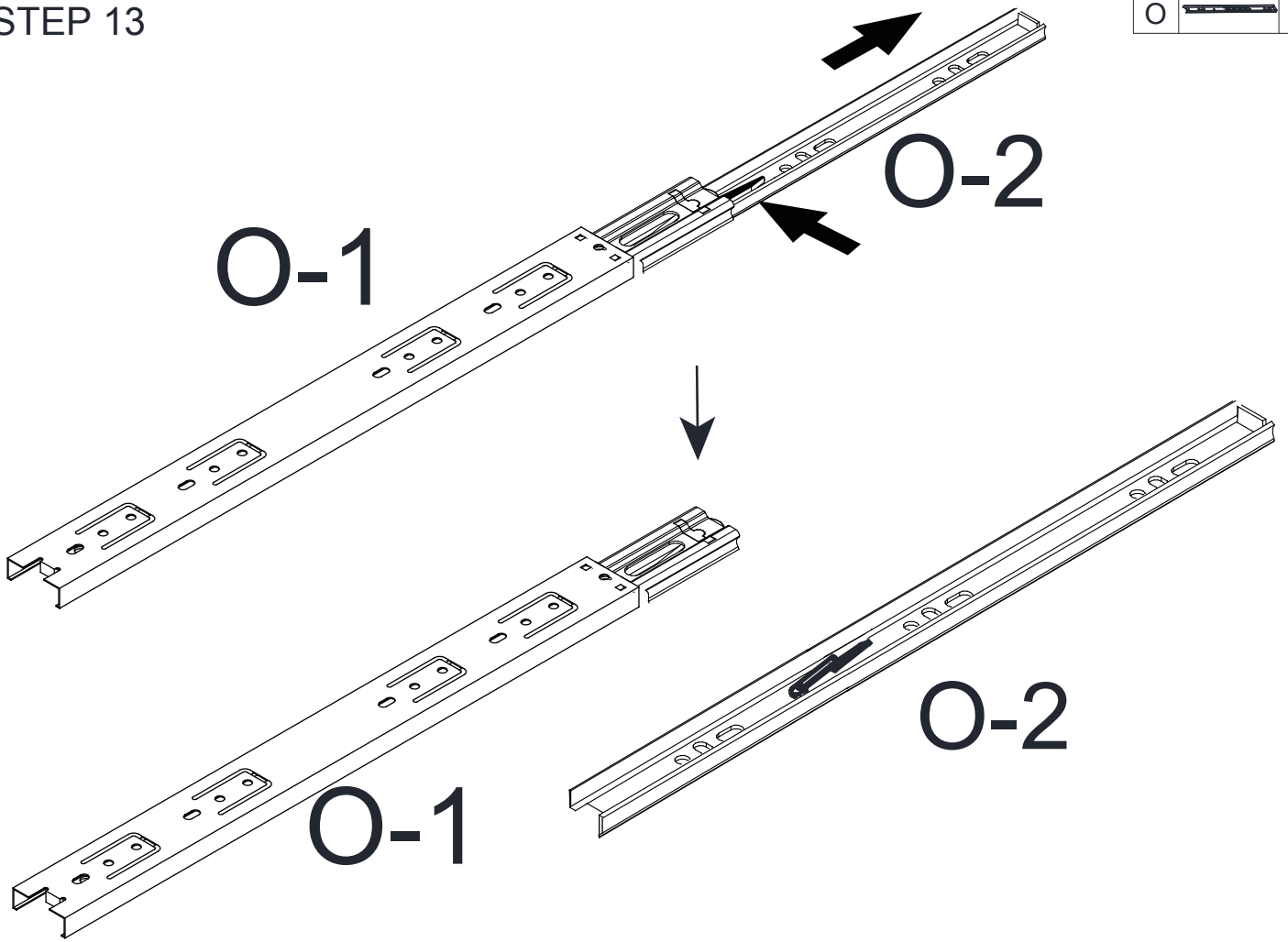

STEP 13

0  2



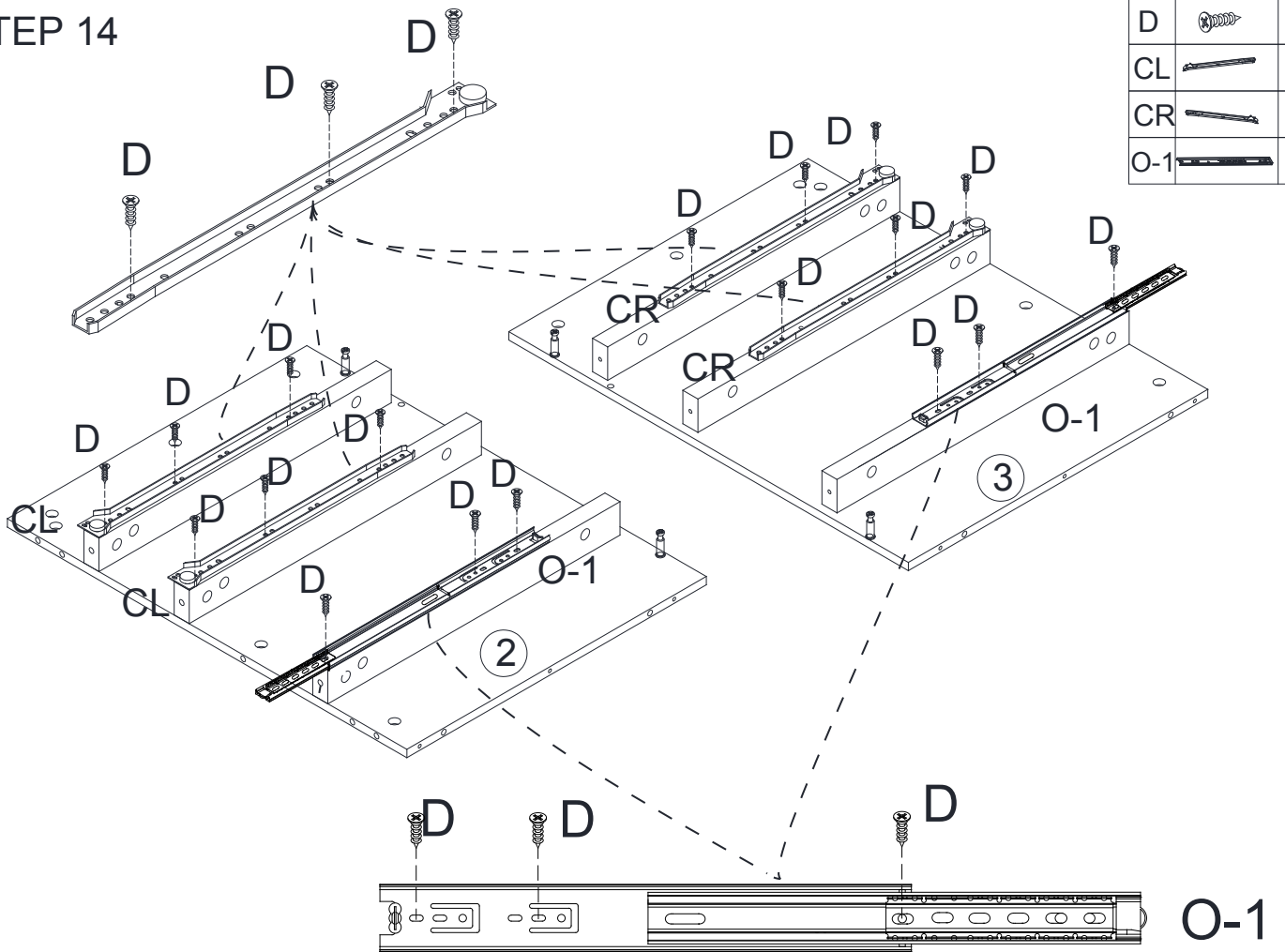

STEP 14

D		18
CL		2
CR		2
O-1		2



# STEP 15

B		4
C		4

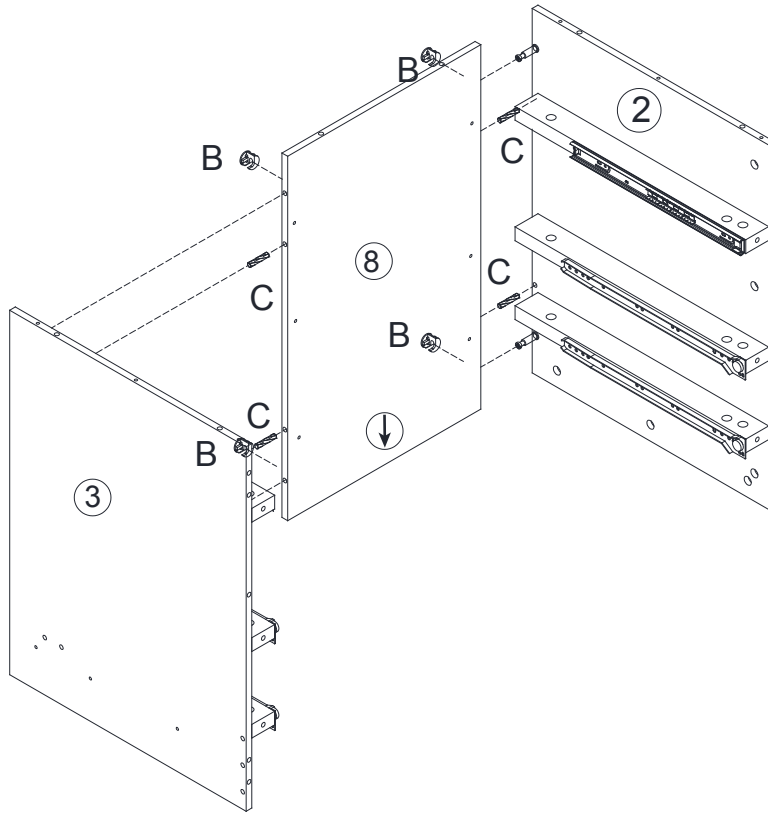

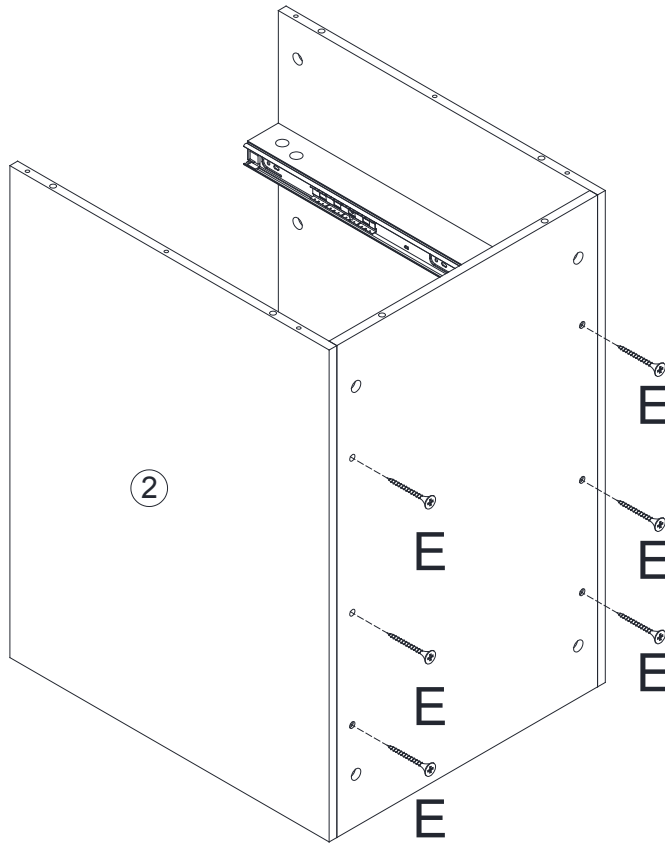

# STEP 16

E		6
---	---	---



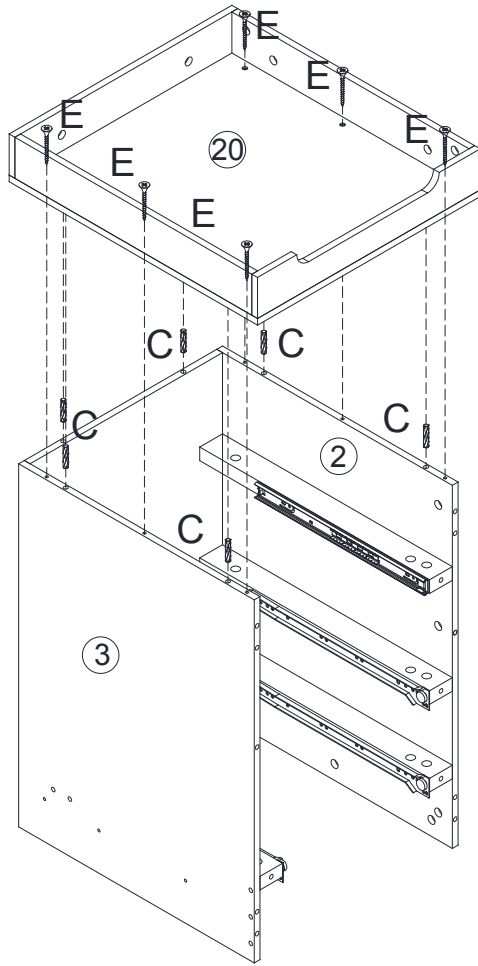

# STEP 17

E		6
C		6





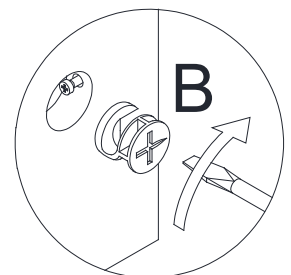
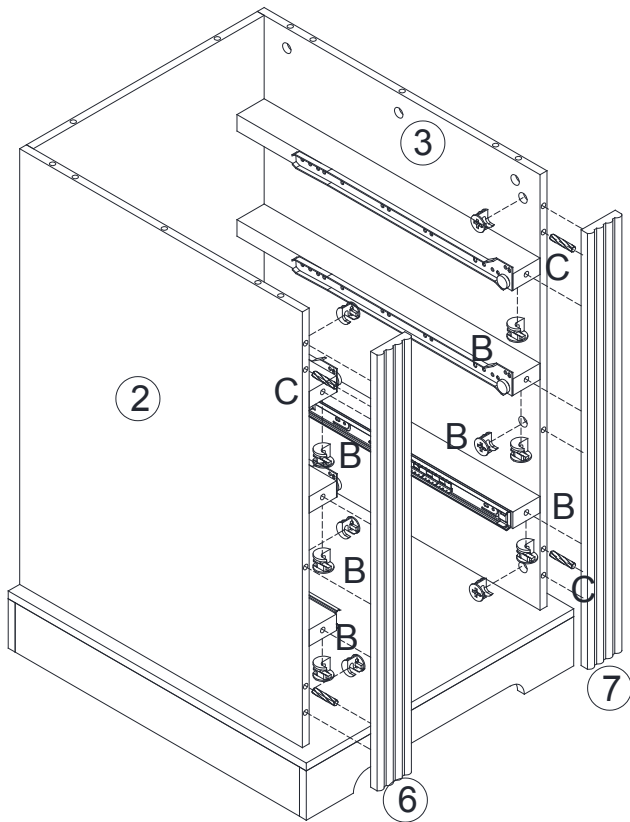

# STEP 18

B		12
C		4



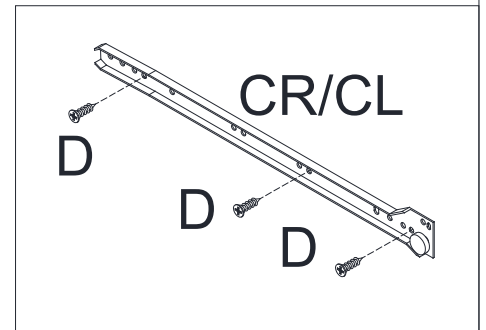
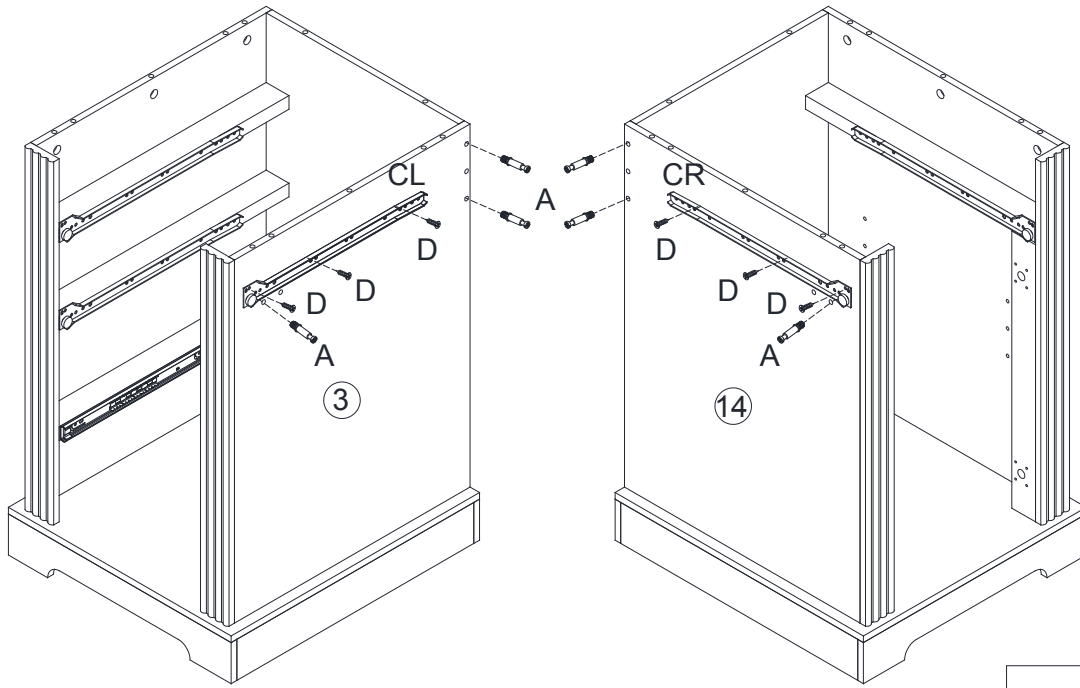

# STEP 19

A		6
D		6
CL		1
CR		1



# STEP 20

B		6
C		4

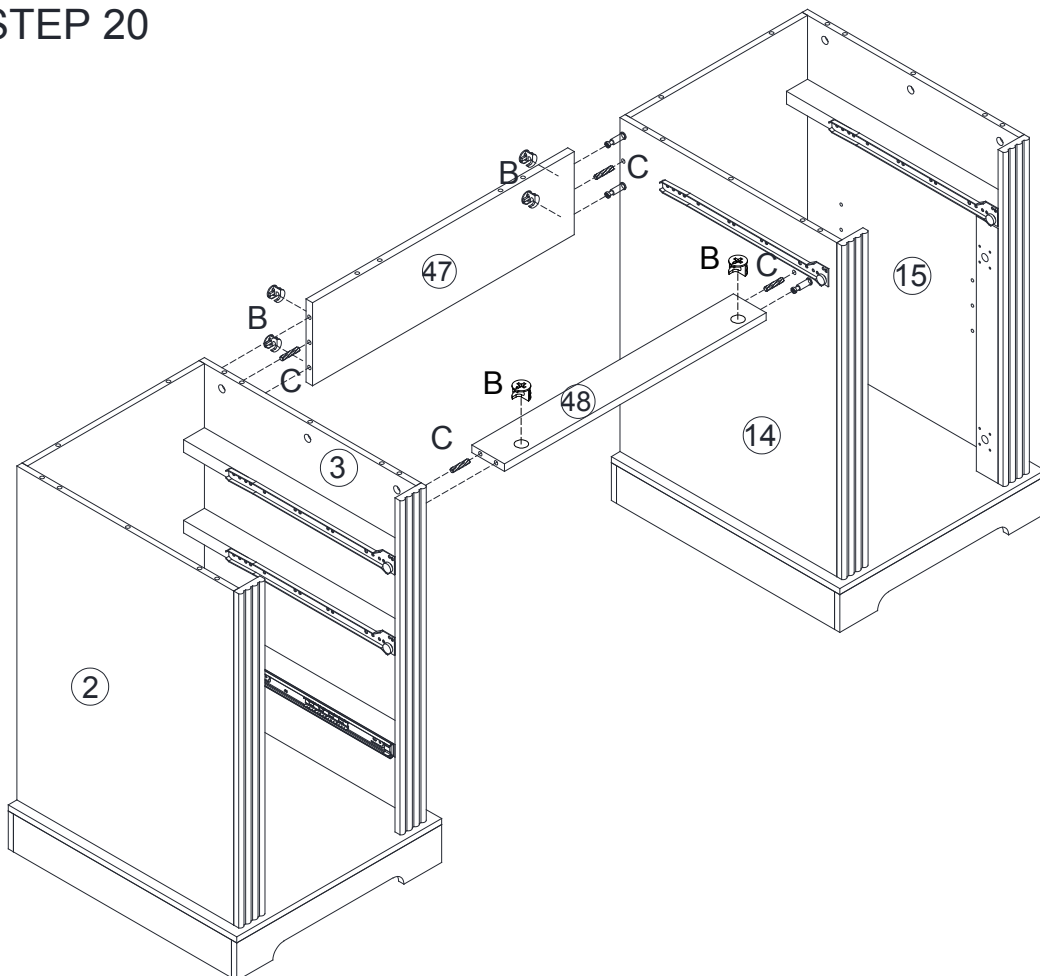

# STEP 21

A		24
---	---	----

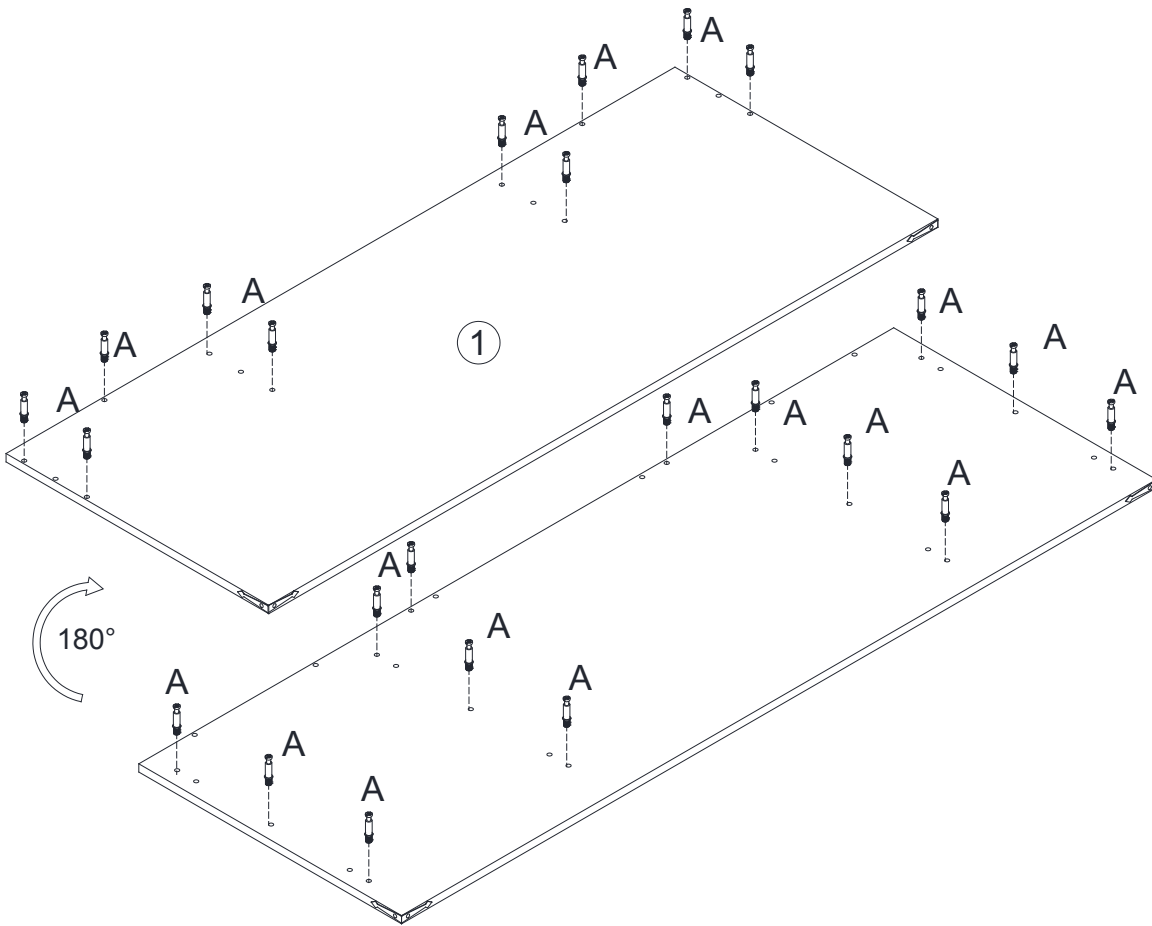

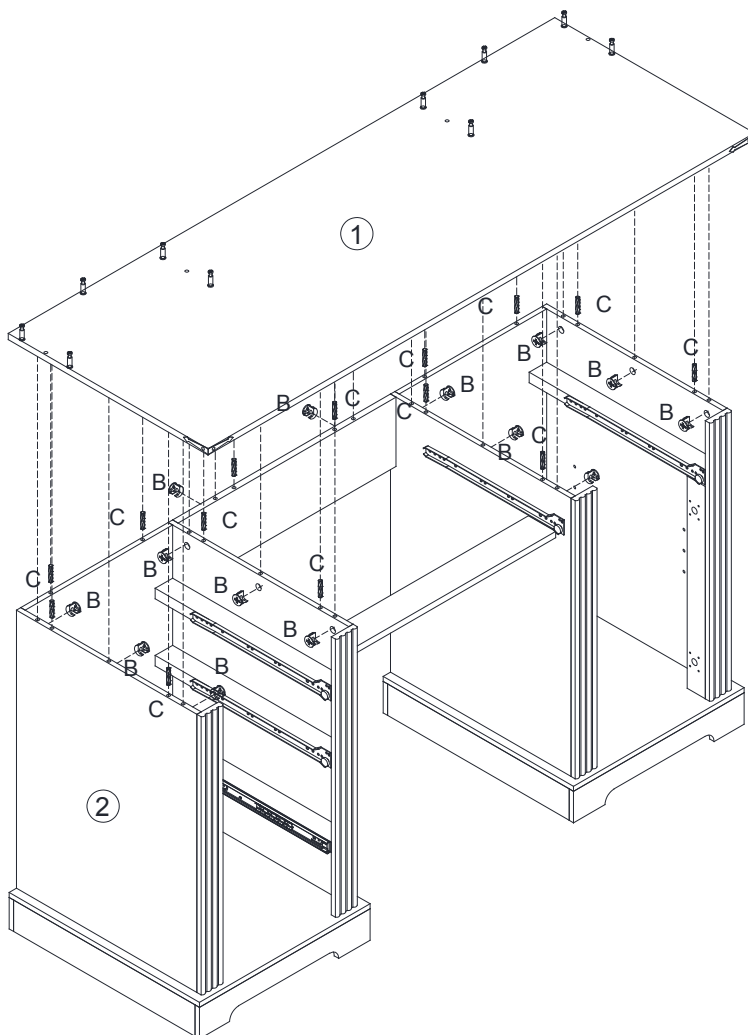

# STEP 22

B		14
C		14



# STEP 23

B		10
C		12

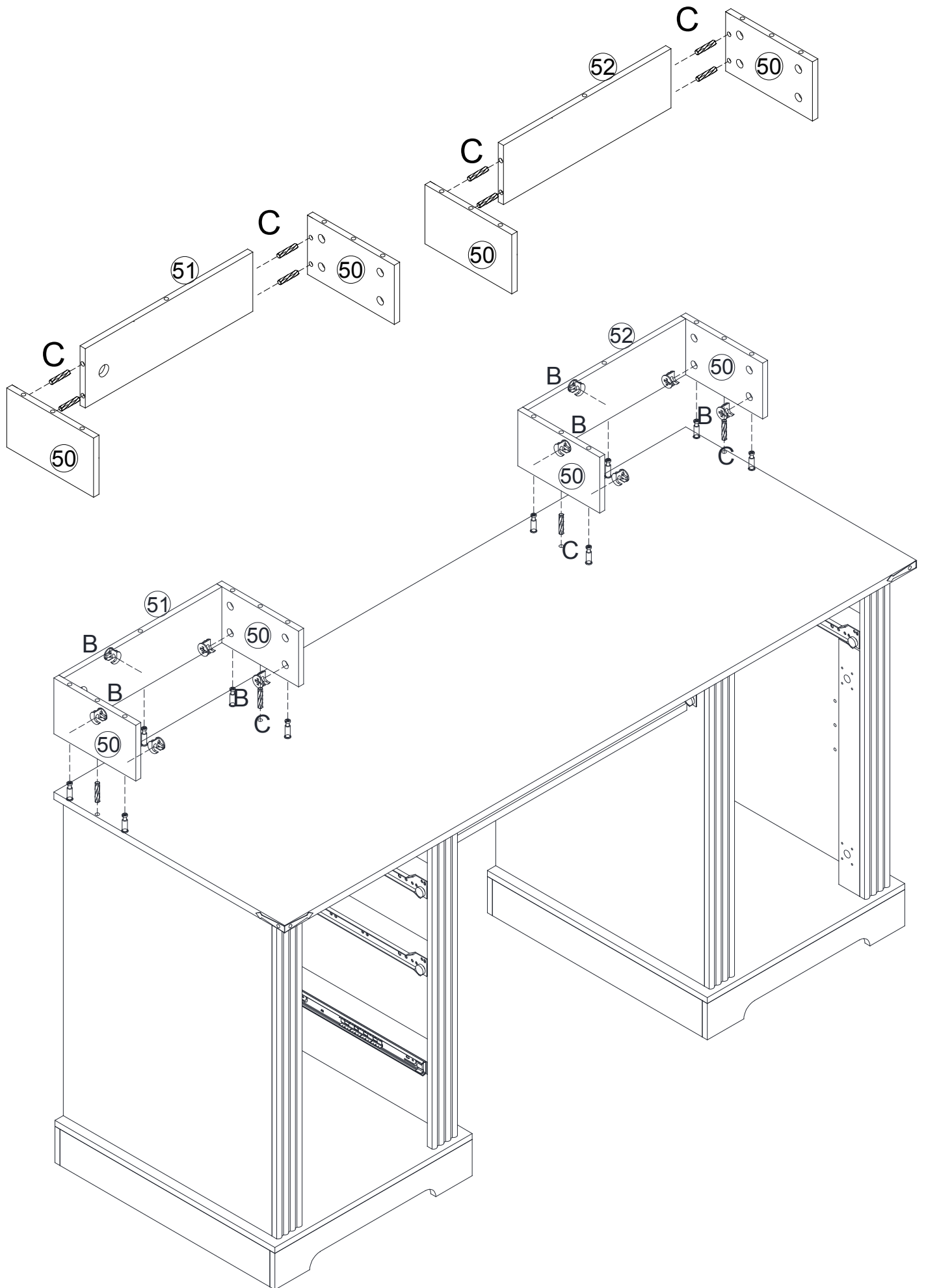

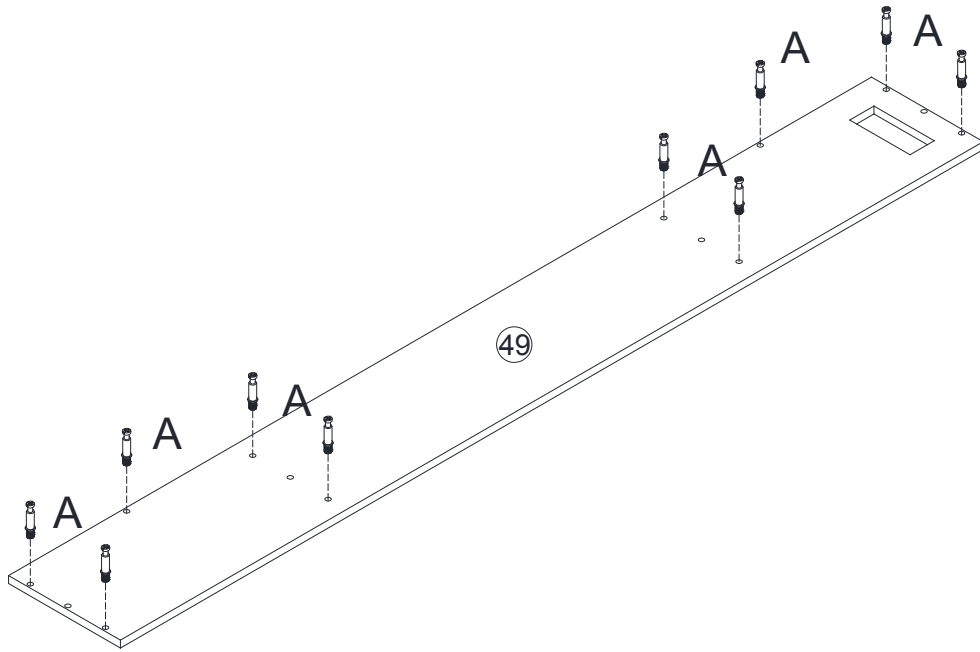

# STEP 24

A		10
---	---	----







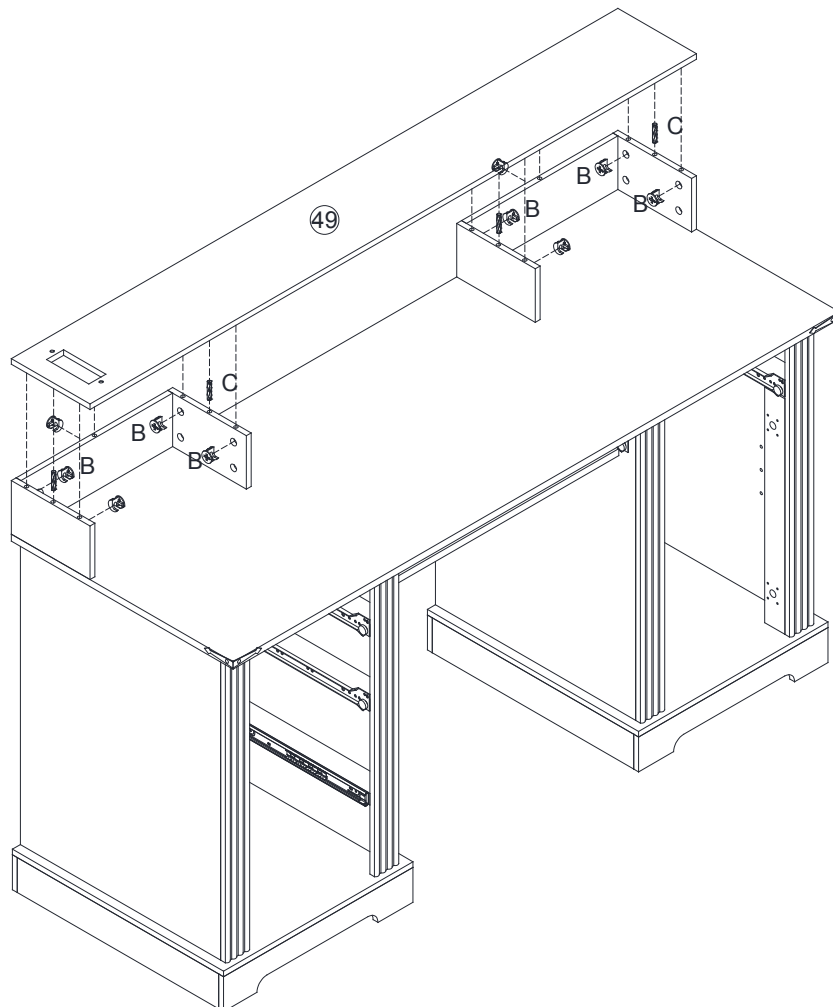



# STEP 25

B		10
C		4



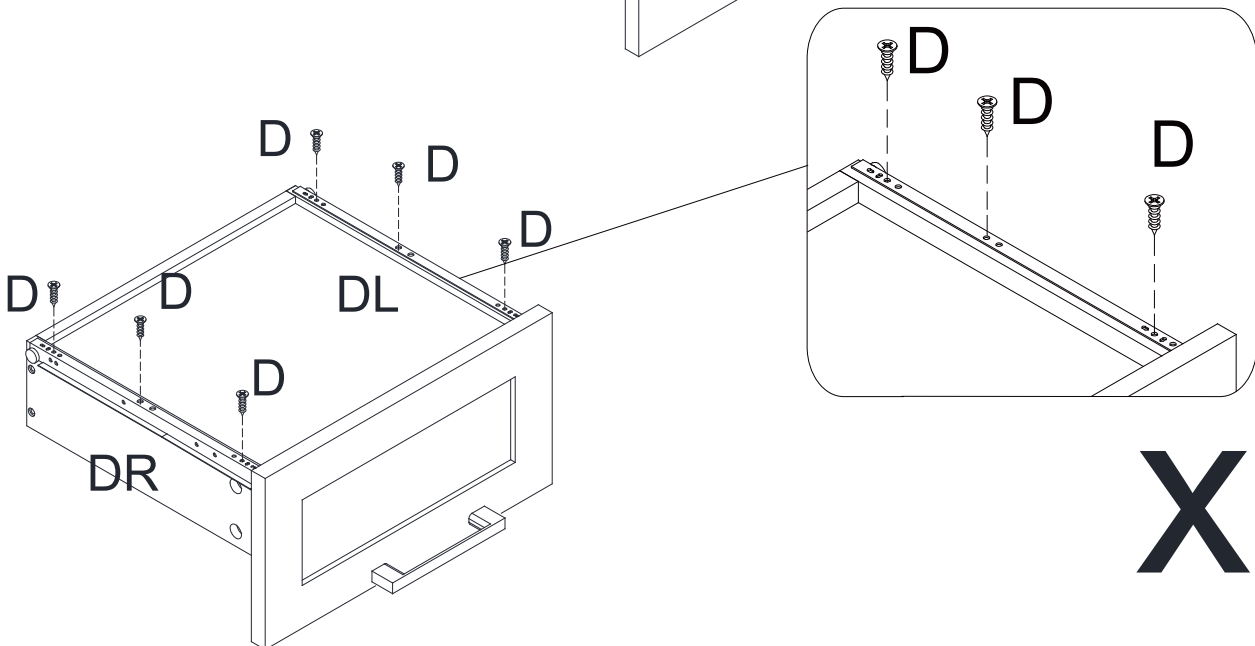
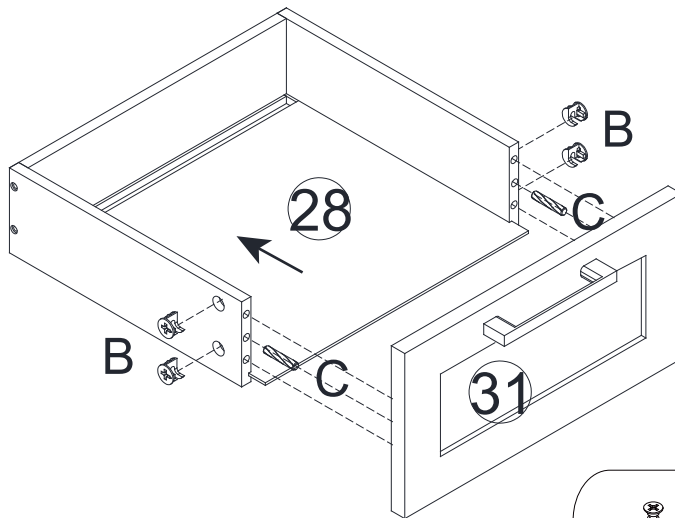
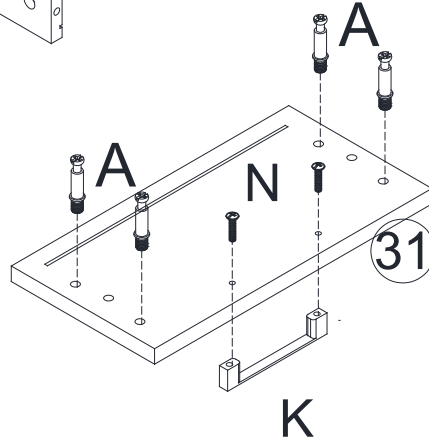
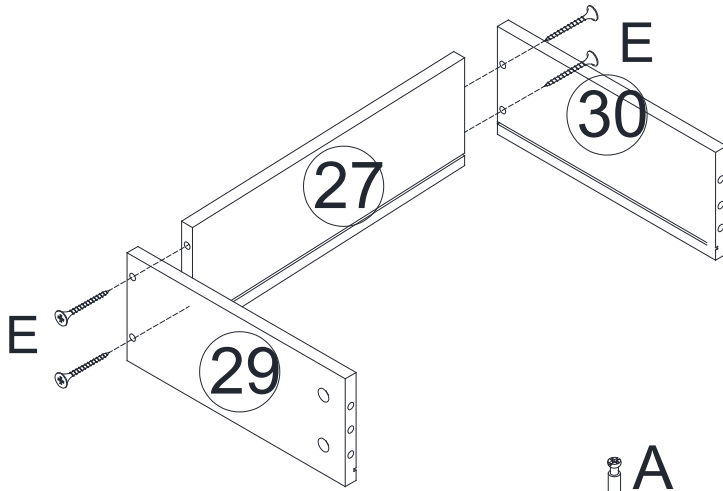

# STEP 26

N		6	A		12
C		6	B		12
K		3	D		18
			E		12
			DL		3
			DR		3



**x3**

# STEP 27

H		2
L		1

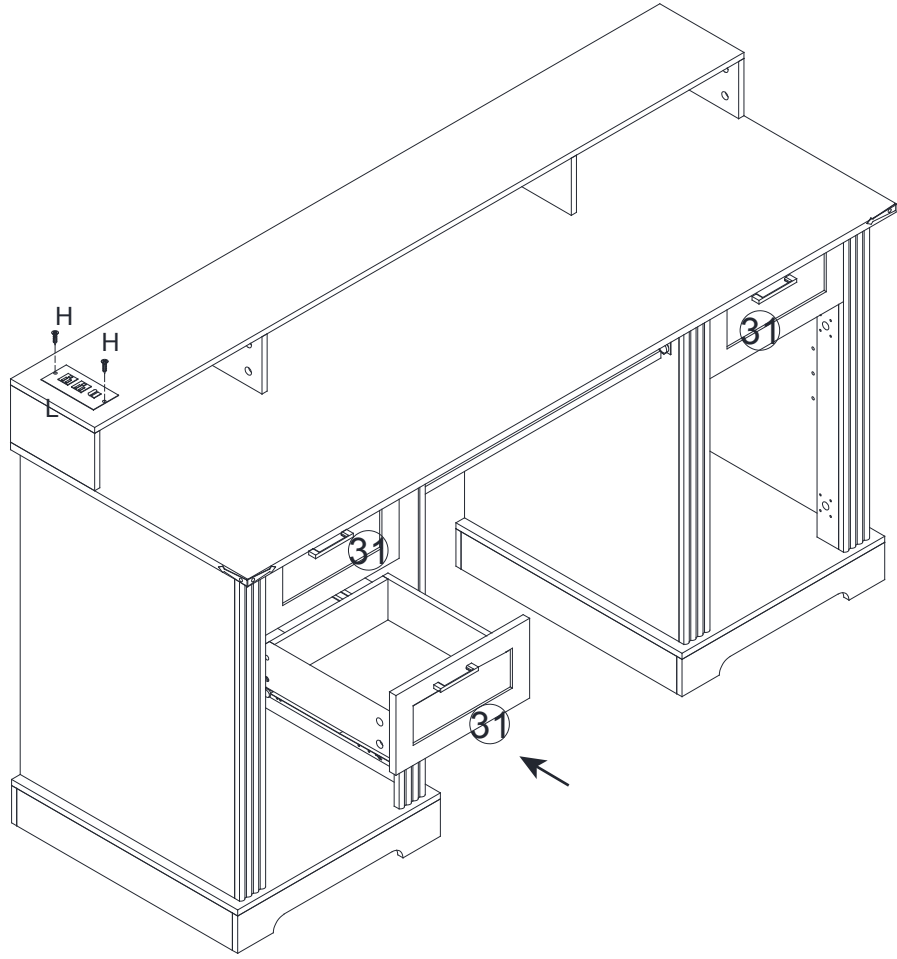
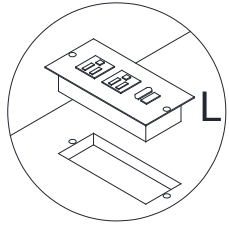

# STEP 28

M		4
---	---	---

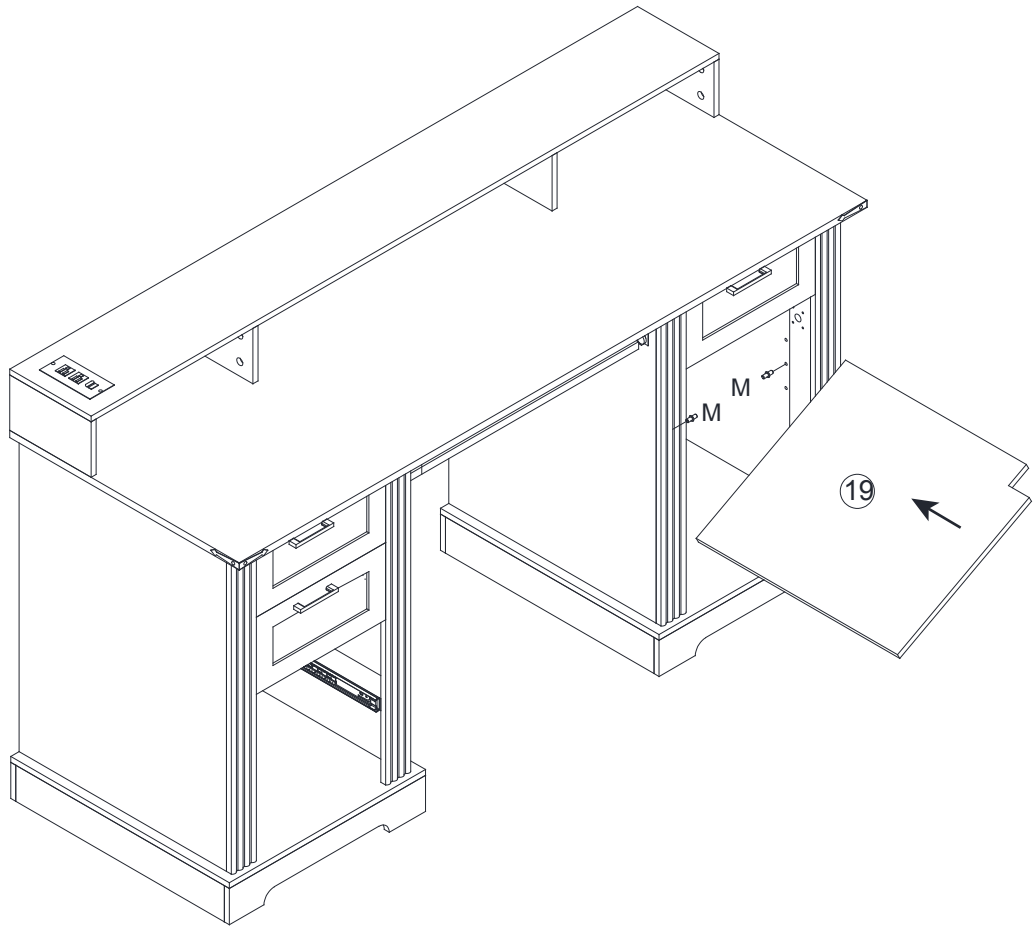





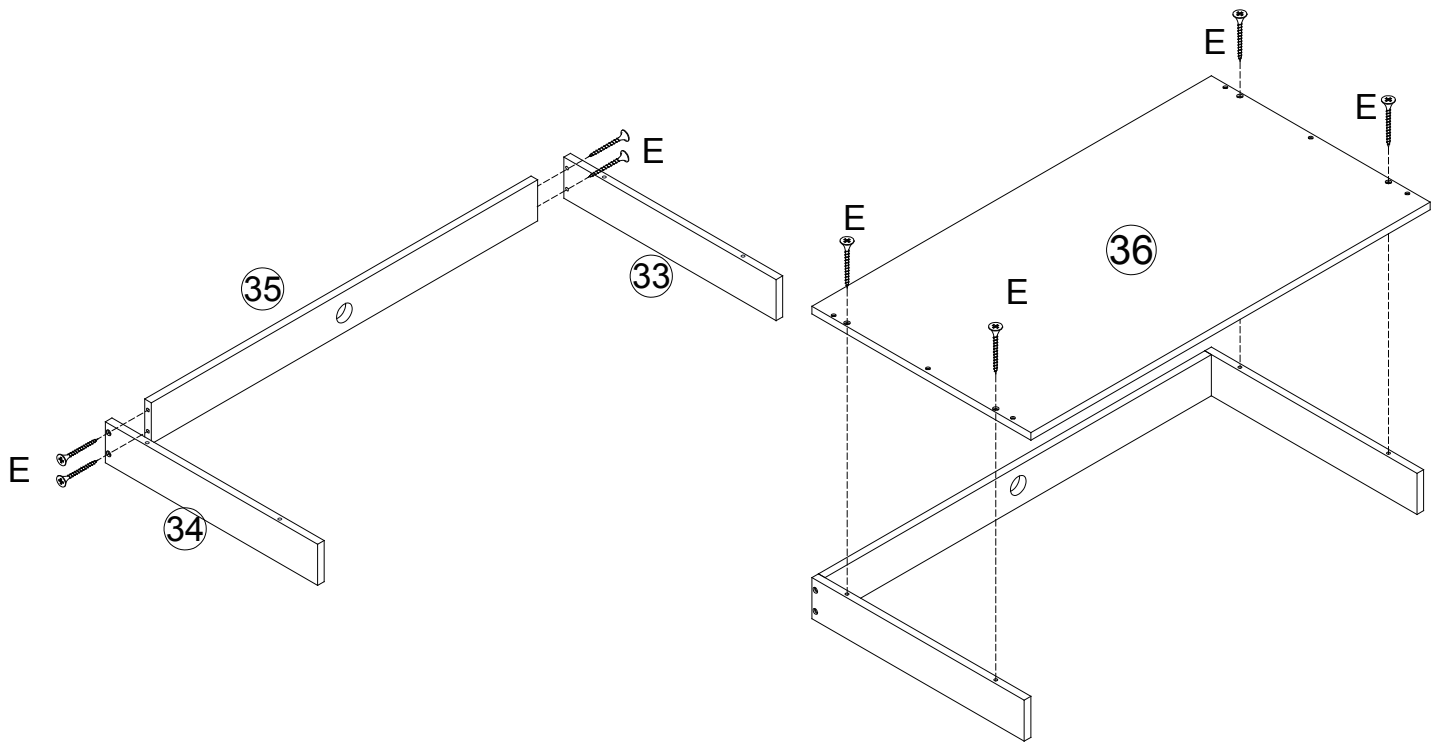

# STEP 29

E  8



# STEP 30

I		2
G		2
H		8
J		3
DL		1
DR		1
D		6

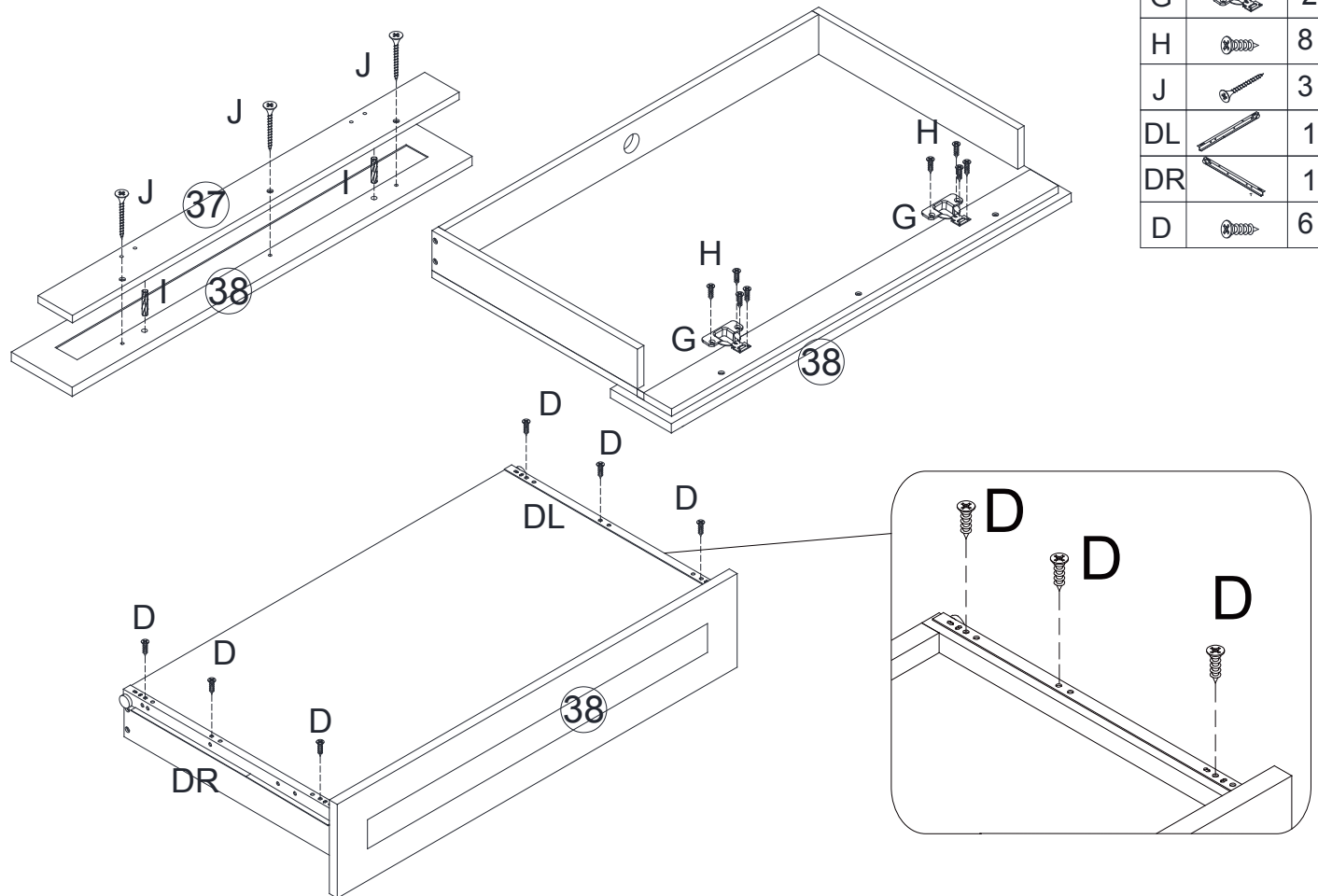



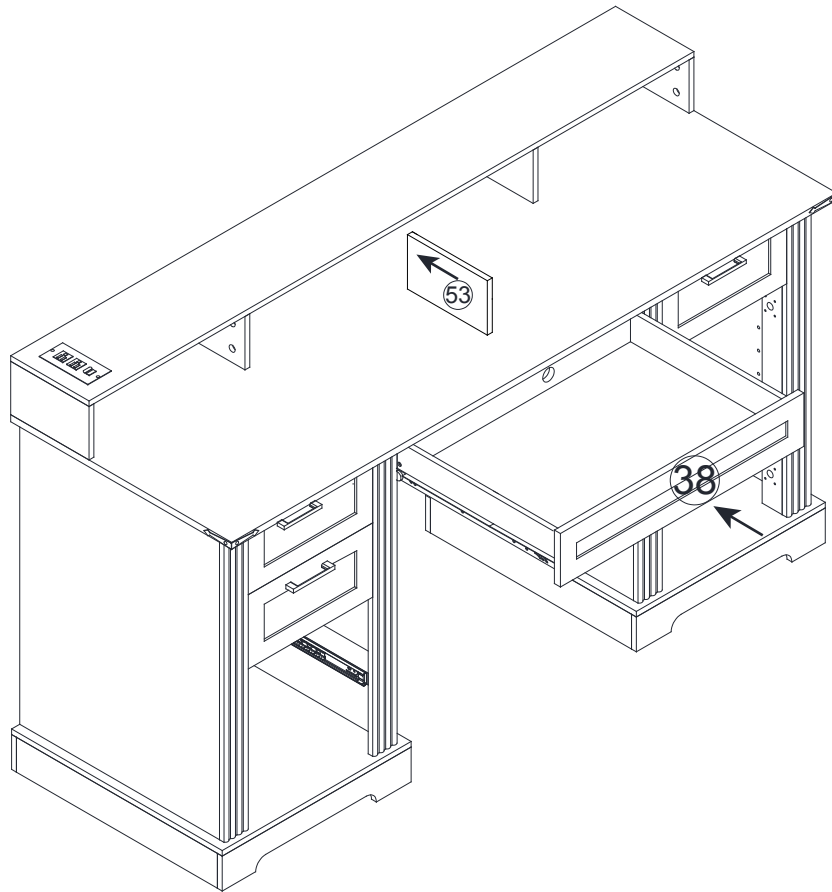

# STEP 31

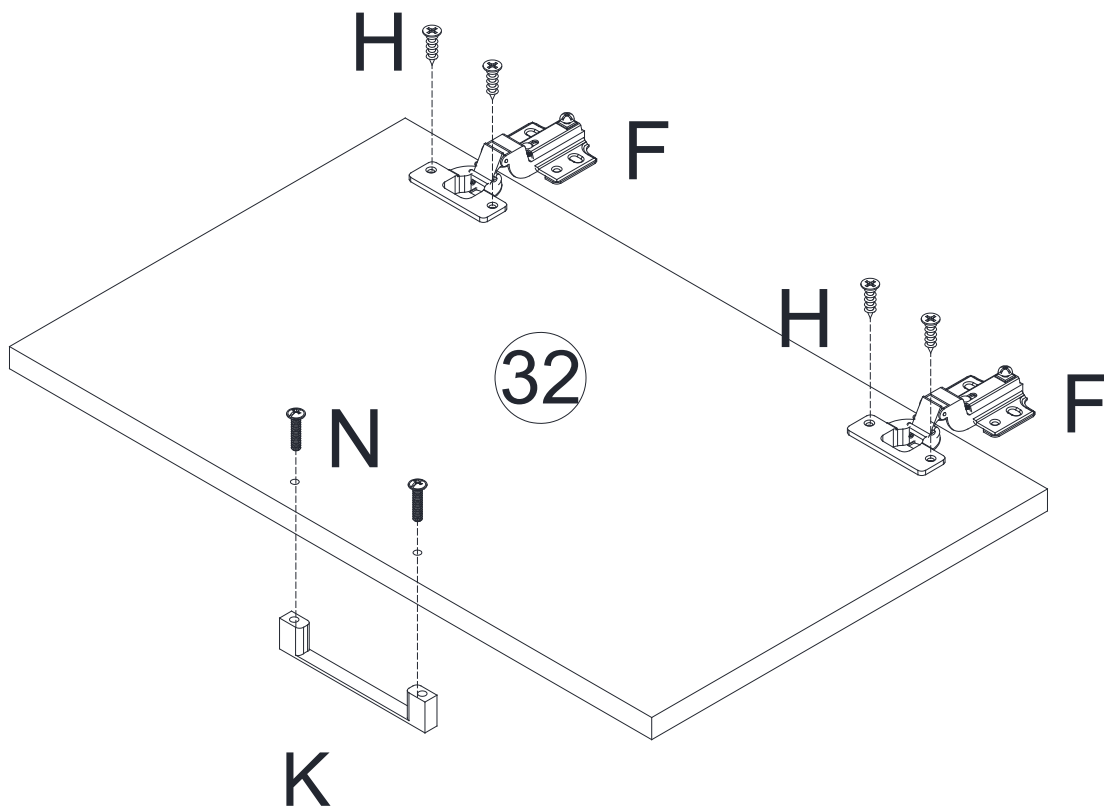

# STEP 32





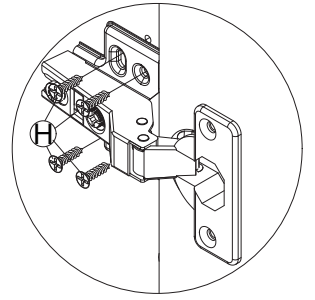
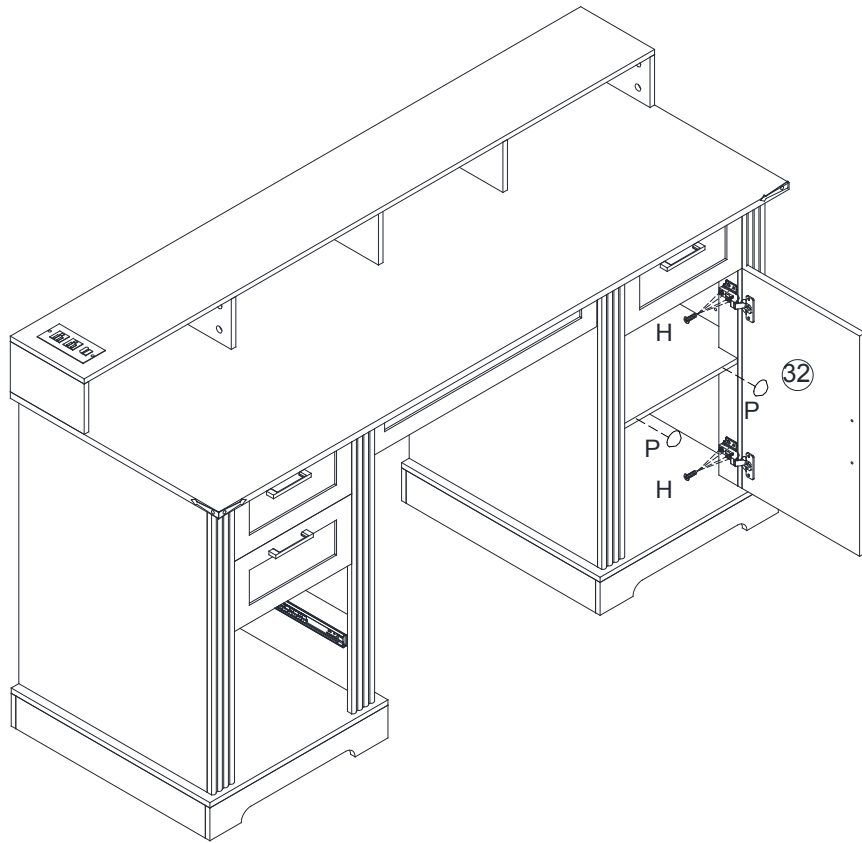

H		4
F		2
N		2
K		1

# STEP 33

H		8
P		2



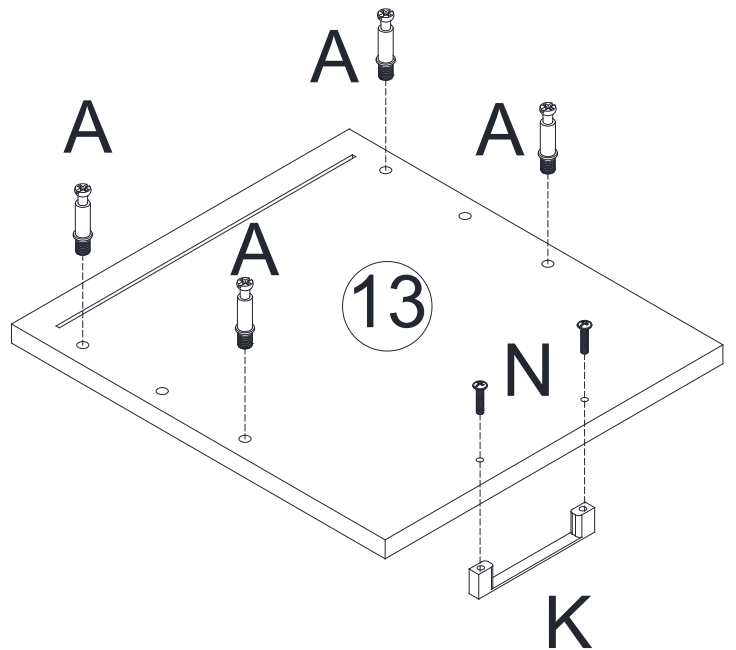
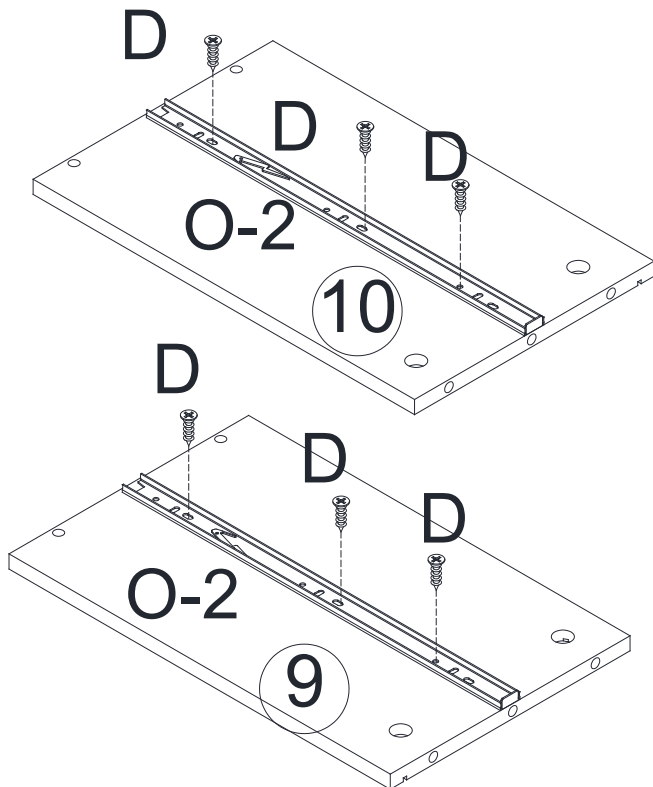

# STEP 34

N		2
K		1
A		4
D		6
O-2		2







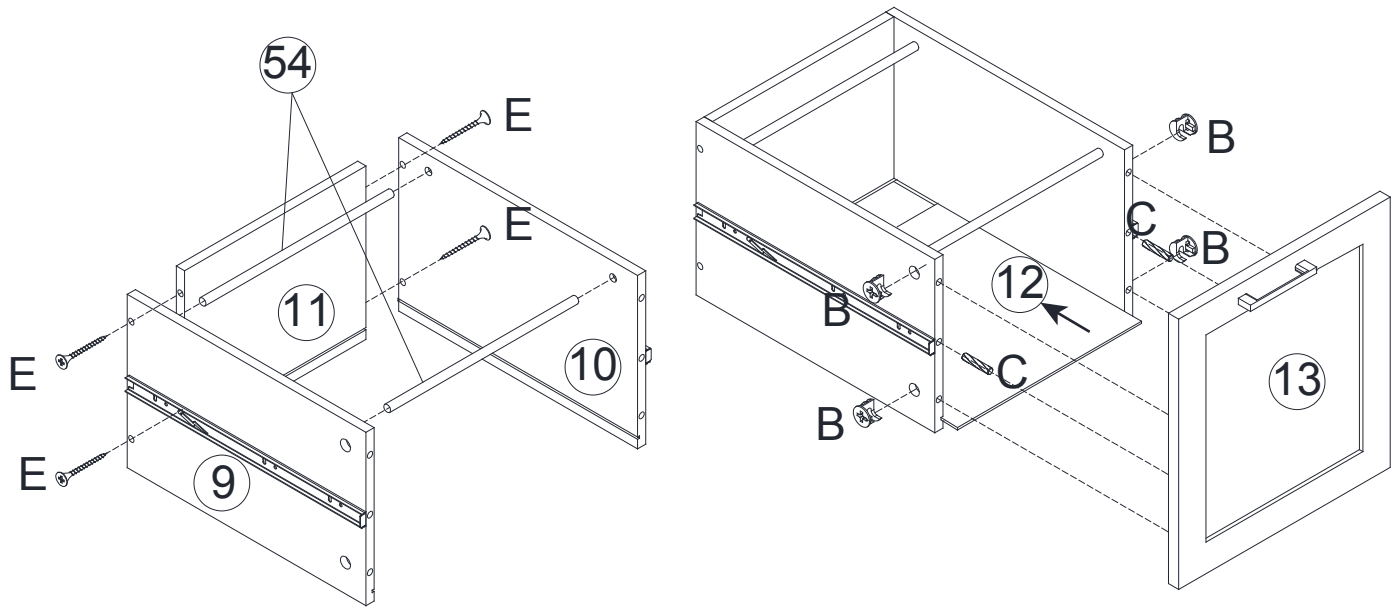

# STEP 35

B		4
E		4
C		2



# STEP 36

A		2
B		2
E		4
N		2
C		2
K		1

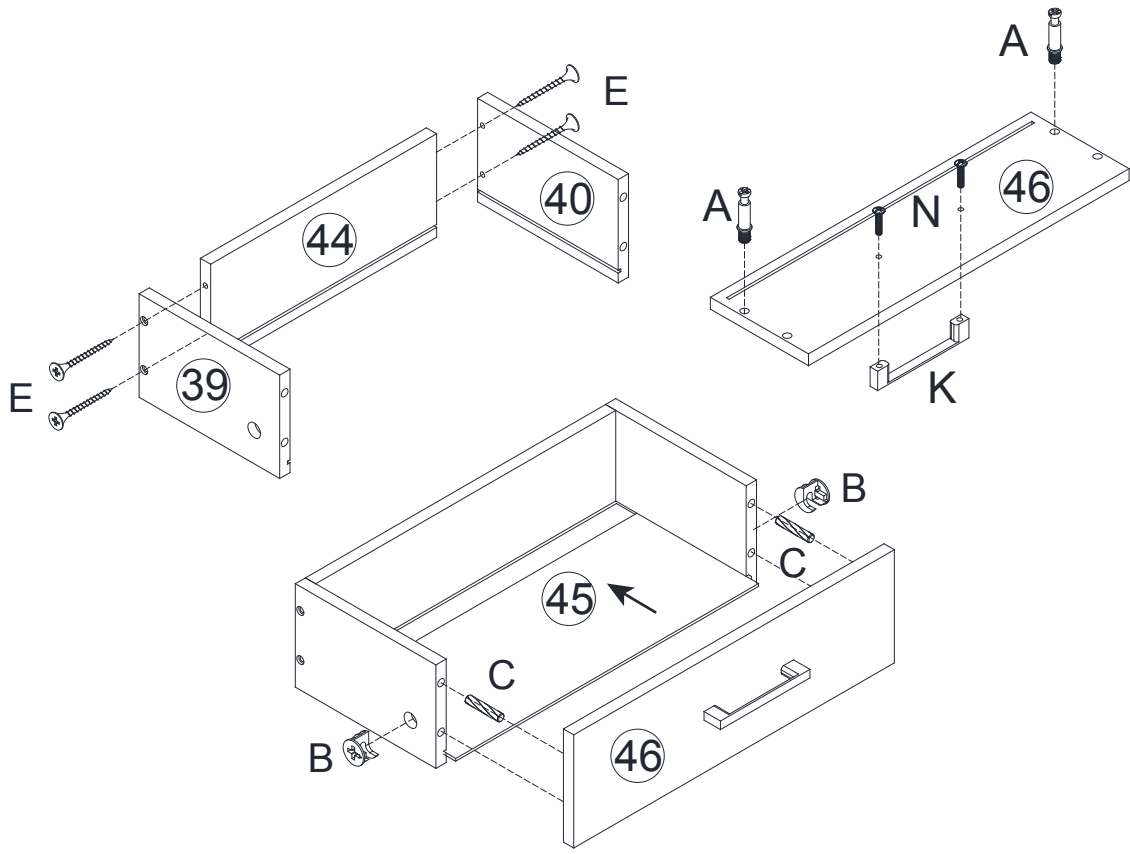

# STEP 37

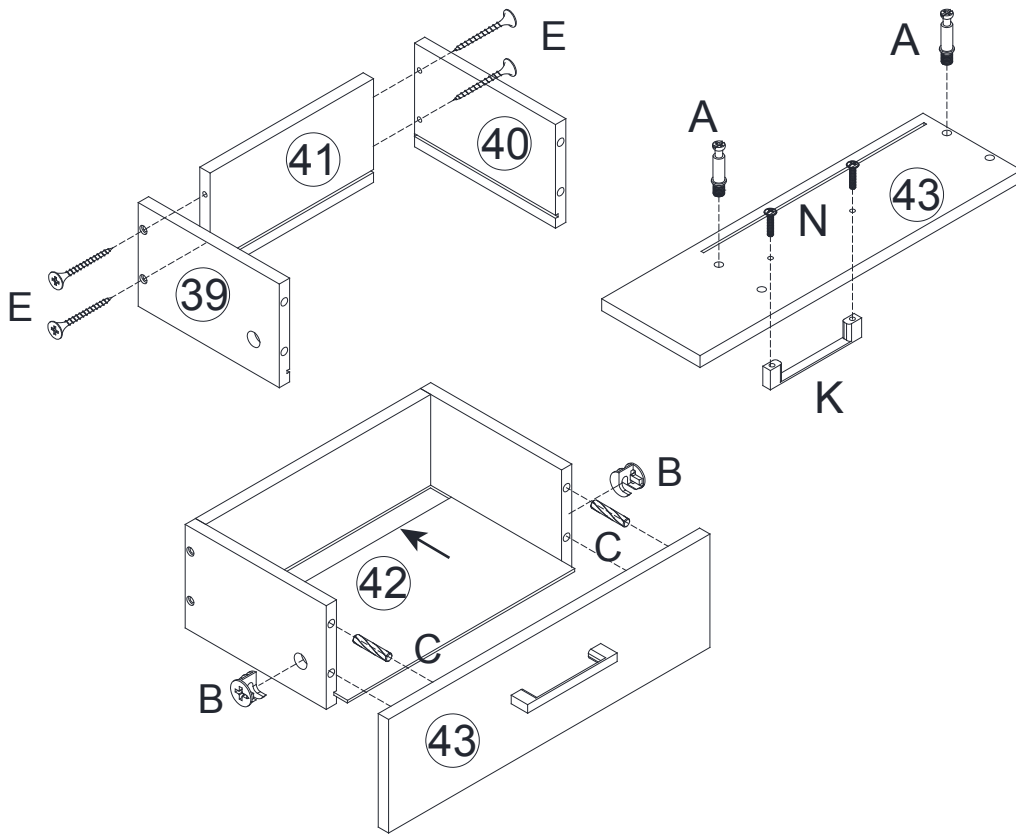

A		2
B		2
E		4
N		2
C		2
K		1

# STEP 38

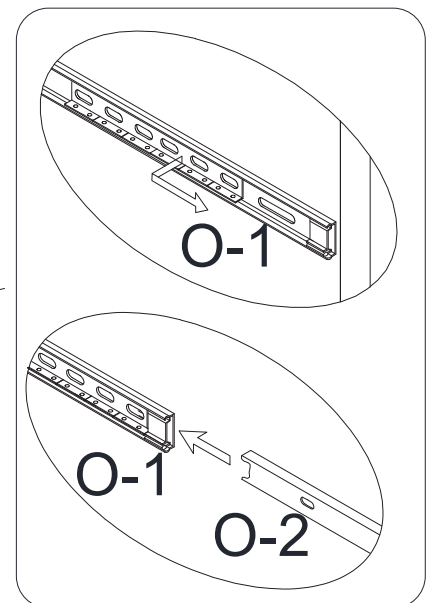
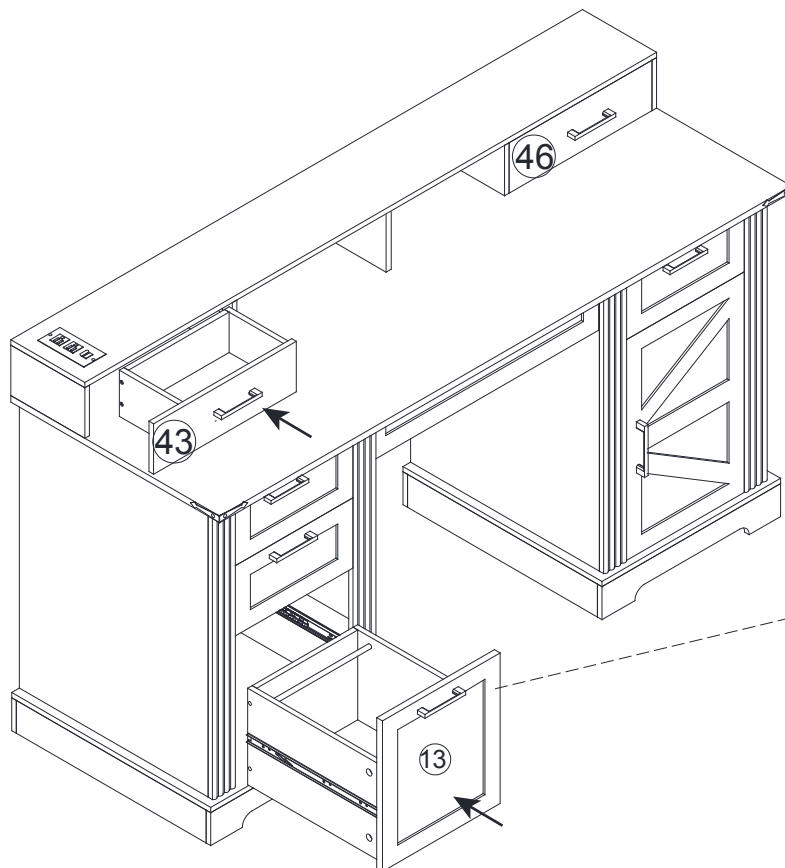

COMPLETE:

