

Furniture of America®

Assembly Instructions

For more information contact our team: service.ec@foagroup.com

CM-BK929-VN

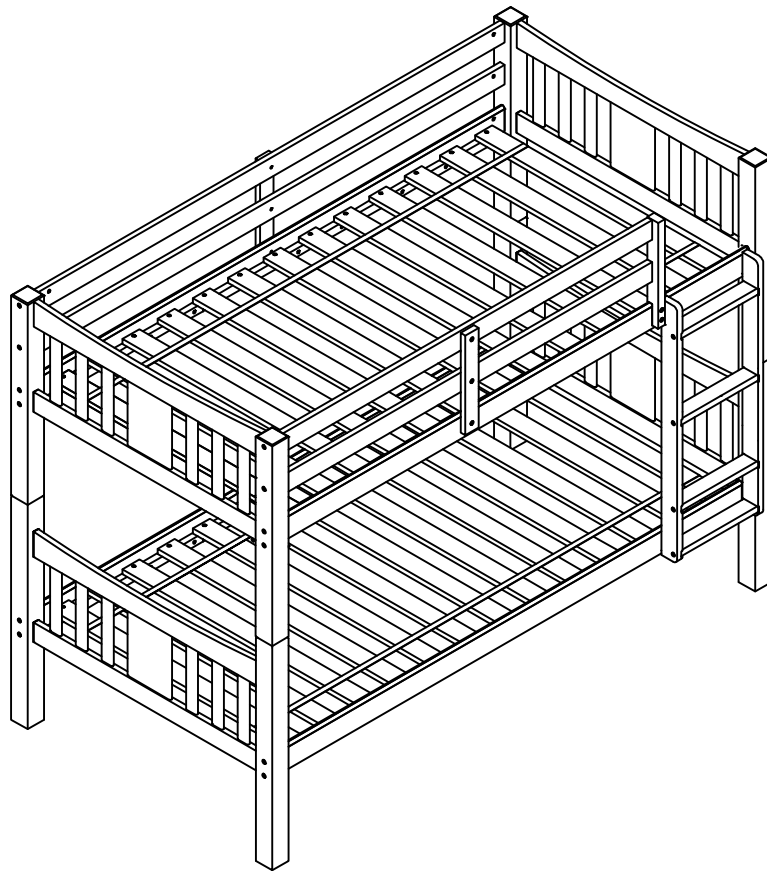

ASSEMBLY RATING

The Assembly Rating is a 5-point system that shows the degree of effort needed in assembling a specific product (with 1 being easy and 5 being difficult). For some products, two persons are recommended.

EASY  DIFFICULT

Tools Required For Assembly:

Allen Wrench

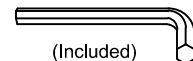

(Included)

Phillips Screwdriver



(Not Included)



2 PERSONS RECOMMENDED

ASSEMBLY & CARE ADVICE

FOR YOUR FURNITURE TO LAST, CORRECT ASSEMBLY AND PROPER MAINTENANCE ARE NECESSARY. PLEASE FOLLOW THE INFORMATION PROVIDED BELOW TO FULLY ENJOY YOUR FURNITURE.

BASIC ASSEMBLY TECHNIQUES

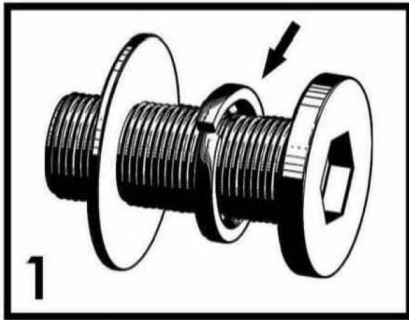

When lock or spring washer is used in an assembly, please make sure the lock or spring washer is placed between the larger flat washer and the head of the screw or bolt.

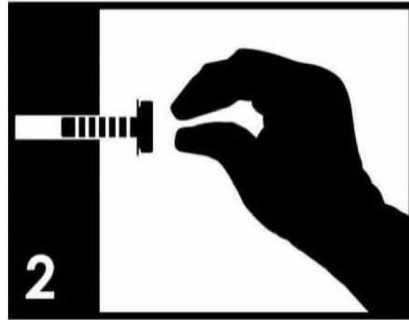

Position each part correctly and insert screws or bolts into their respective holes by hand tighten or using the proper hand tool. Only tighten when step is completed or when instructed to do so.

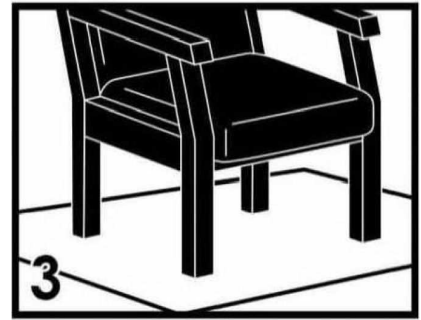

Use cardboard or carpet area when assembling furniture to prevent scratches. Make sure the furniture rests on a flat and level surface with each leg evenly touching the floor. No dragging of products/parts.

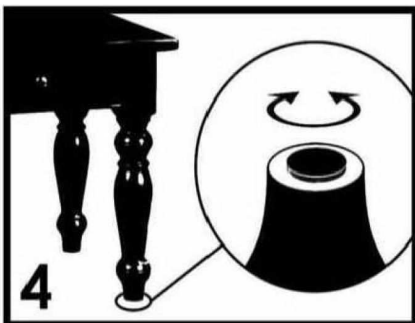

Some furniture comes with height adjustment knobs underneath each leg. To lower or to raise each leg, you need to turn clockwise or counterclockwise, respectively.

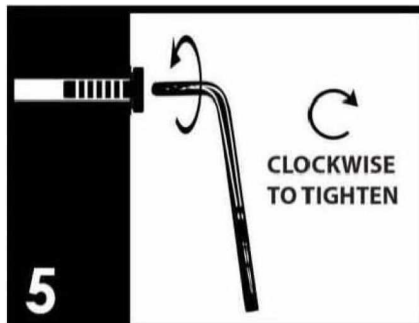

Make sure all parts are properly aligned, then use the appropriate hand tool to completely tighten the bolts or screws. Do not use power tools and do not overtighten.

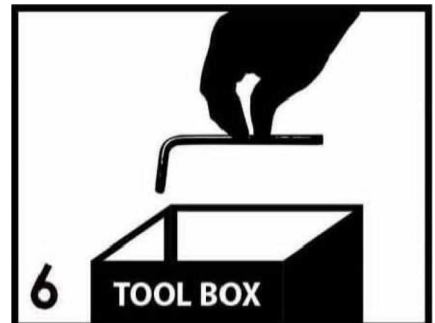

Save the instructions and store the Allen wrench or any supplied tool for later maintenance. After two weeks, check and tighten any loose hardware and repeat again every six months thereafter.

IT IS THE USER'S RESPONSIBILITY TO MAINTAIN THE FURNITURE. THE HARDWARE MAY LOOSEN OVER TIME AND MAY CAUSE THE FURNITURE TO BE WOBBLY AND UNABLE TO SUPPORT ITS INTENDED WEIGHT CAPACITY. THIS MAY LEAD TO COLLAPSE AND MAY CAUSE SERIOUS INJURY.

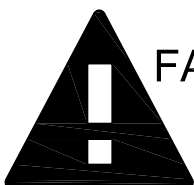

FAILURE TO FOLLOW THE GUIDELINES ABOVE MAY RESULT IN INJURY AND/OR PROPERTY DAMAGE.

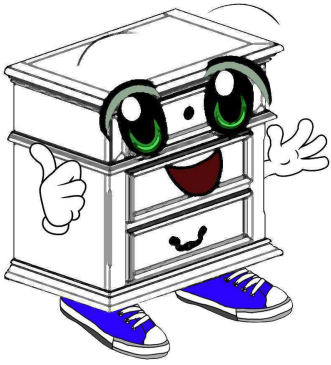

Before you begin, please read Page 2 of "Assembly and Care Advice".

And remember, do not tighten until each step is completed or instructed.

Parts List

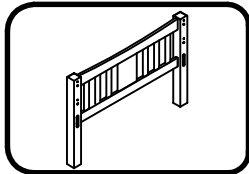

#1 x 1pc
Upper Headboard

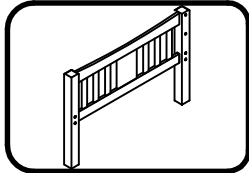

#2 x 1pc
Upper Footboard

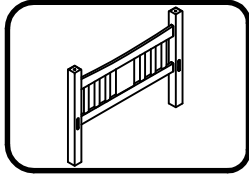

#3 x 2pcs
Lower Head & Footboard

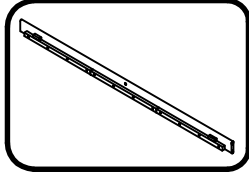

#4 x 1pc
Upper Side Rail (Back)

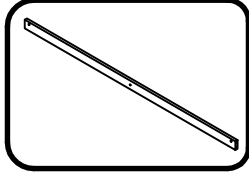

#5 x 2pcs
Long Guard Rail

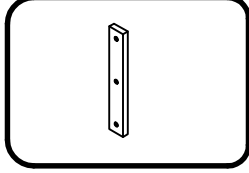

#6 x 2pcs
Vertical Guard Rail Support

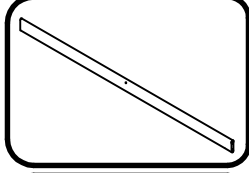

#7 x 1pc
Upper Side Rail (Front)

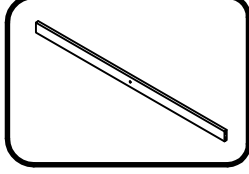

#8 x 2pcs
Short Guard Rail

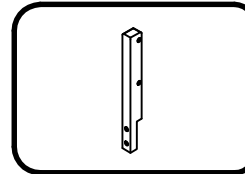

#9 x 1pc
Front Guard Rail Support

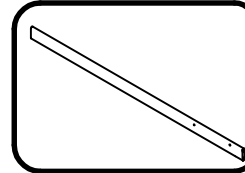

#10 x 1pc
Lower Side Rail (front)

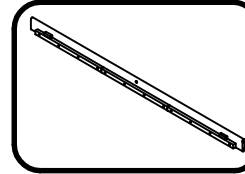

#11 x 1pc
Lower Side Rail (back)

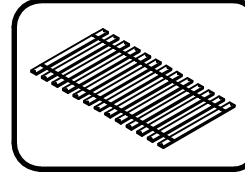

#12 x 2 set
Upper & Lower Slat

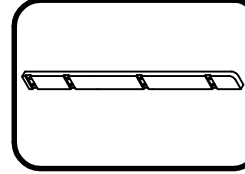

#13 x 1pc
Left Side Rail Ladder

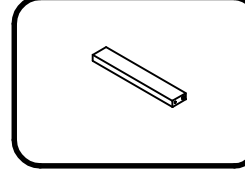

#14 x 4pcs
Step Ladder

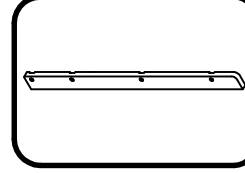

#15 x 1pc
Right Side Rail Ladder

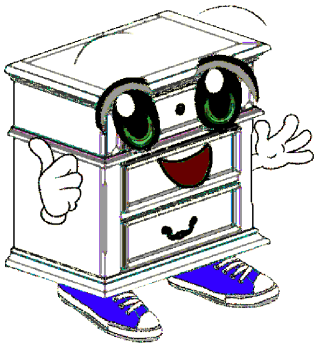

Before you begin, please read Page 2 of "Assembly and Care Advice".

And remember, do not tighten until each step is completed or instructed.

Hardware List

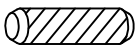

#A x 16pcs
Dowel $\text{\O}3/8"$ x 1-9/16"



#G x 24pcs
Barrel Nut 1/4" x 13 (9.5mm)



#B x 22pcs
Long Bolt 1/4" x 4-3/4"



#H x 8pcs
Wood Screw 1/4"x2-9/16"



#C x 2pcs
Long Bolt 1/4" x 3-1/16"

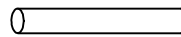

#I x 4pcs
Metal Pin $\text{\O}9.5$ x3-9/16"



#D x 4pcs
Short Bolt 1/4" x 1-9/16"



#J x 52pcs
Wood Screw $\text{\O}3/16"$ x 35mm

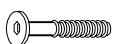

#E x 2pcs
Short Bolt 1/4" x 1-3/8"



#K x 1pc
Allen Wrench M4

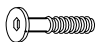

#F x 6pcs
Short Bolt 1/4" x 1-3/16"

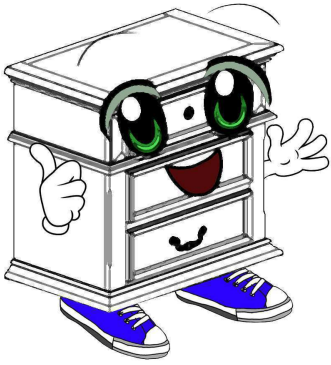

Before you begin, please read Page 2 of "Assembly and Care Advice".

And remember, do not tighten until each step is completed or instructed.

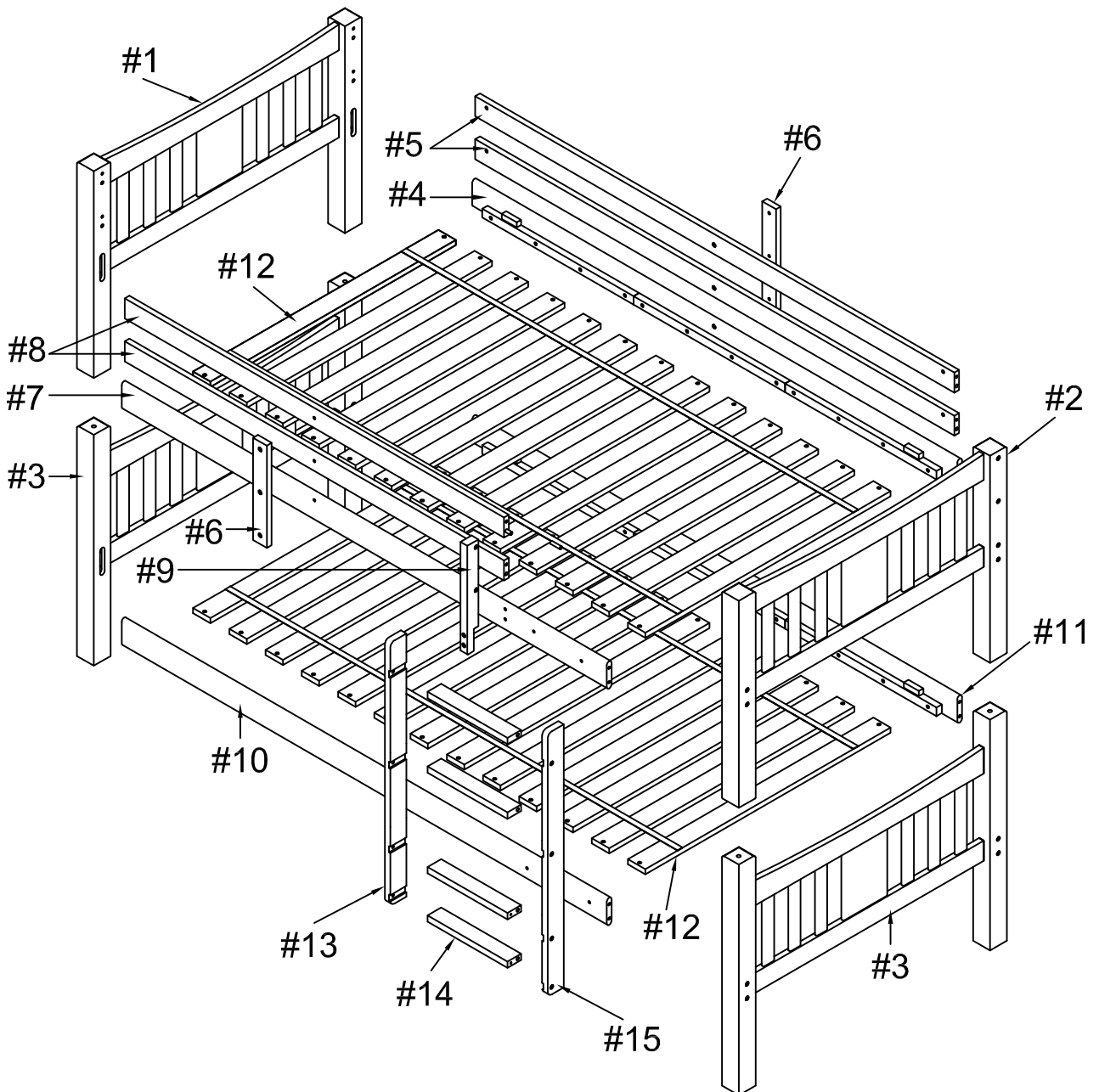



#B x 8pcs
#G x 8pcs

2. Insert 2 barrel nuts (#G) into the pre-drilled holes located on the inner side of each rail end, then 2 long bolts (#B) into the holes along each side of the headboard/footboard. Lock bolt with nut by using the Allen wrench (#K).

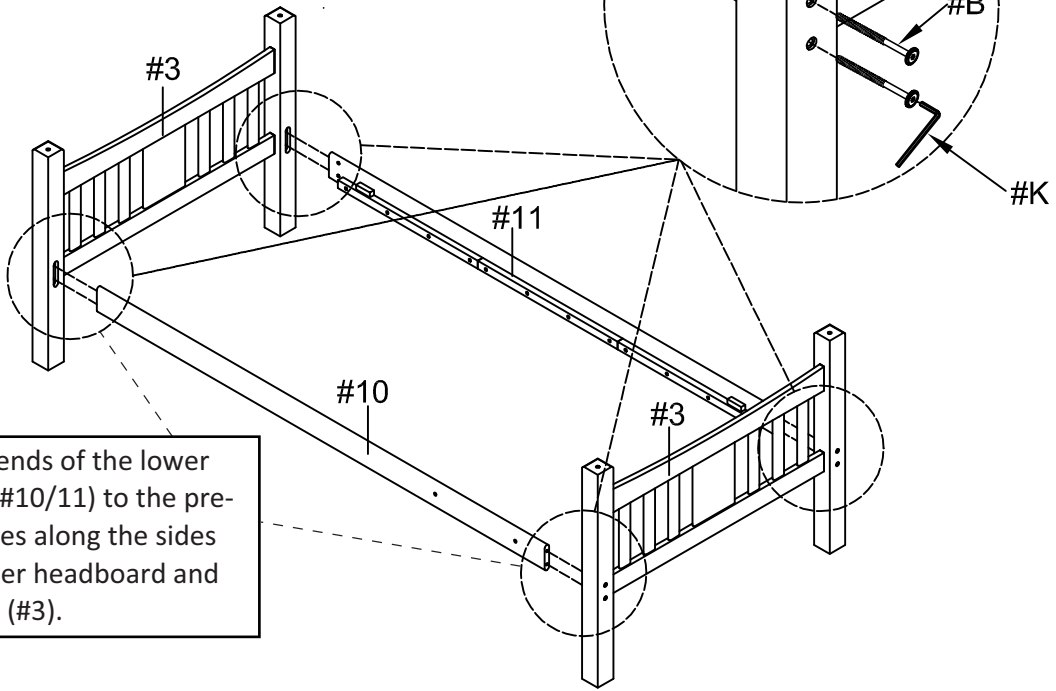

1. Align the ends of the lower side rails (#10/11) to the pre-drilled holes along the sides of the lower headboard and footboard (#3).



#A x 4pcs
#B x 8pcs
#F x 3pcs
#G x 8pcs

4. Align the vertical guard rail support (#6) to the pre-drilled holes along the center of the rails. Insert 3 short bolts (#F) and secure using the Allen wrench (#K).

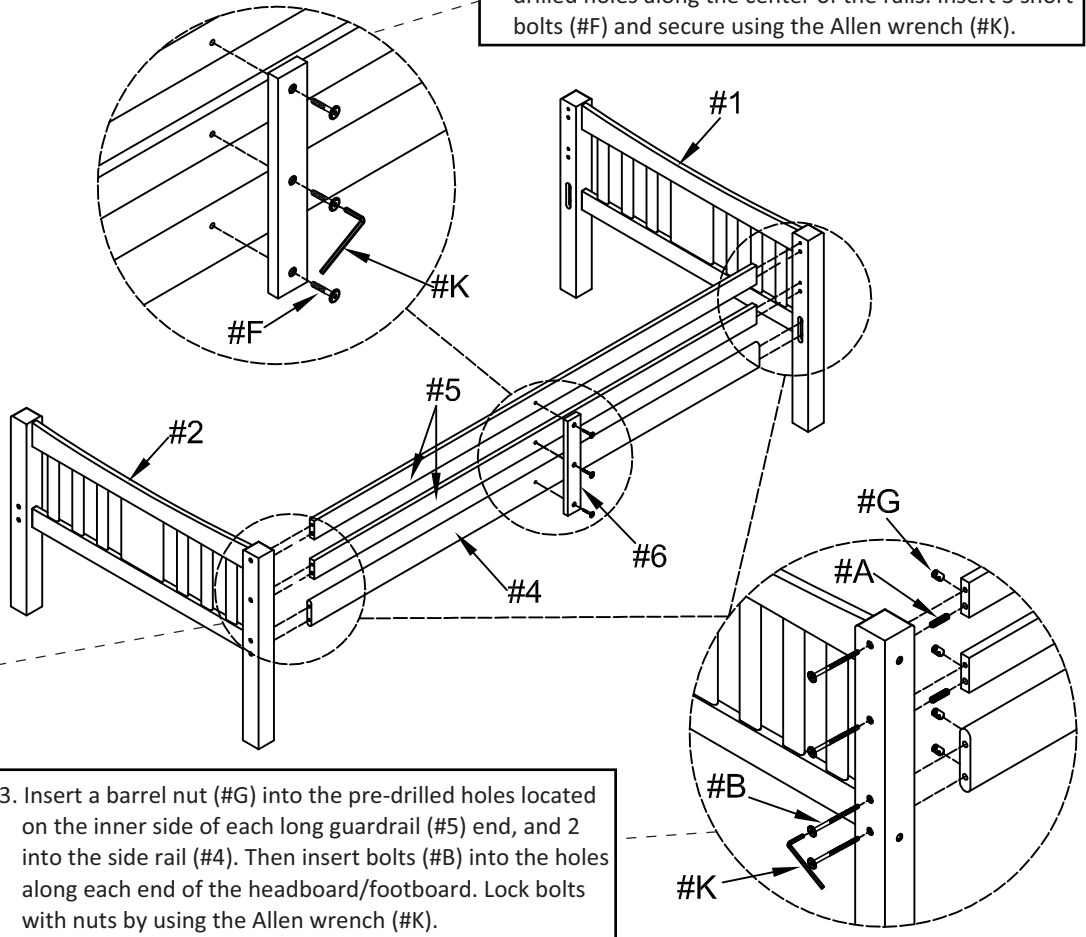

1. Insert a dowel (#A) into each end of the long guardrails (#5). Align the ends of 2 long guard rails (#5) to the top holes and the ends of the upper side rail (#4) to bottom holes along the sides of the upper footboard (#2) and upper headboard (#1)

3. Insert a barrel nut (#G) into the pre-drilled holes located on the inner side of each long guardrail (#5) end, and 2 into the side rail (#4). Then insert bolts (#B) into the holes along each end of the headboard/footboard. Lock bolts with nuts by using the Allen wrench (#K).



#3

Align the short guard rails (#8) to the pre-drilled holes along the side of the upper headboard/footboard (#1/2). Insert a bolt (#B) and barrel nut (#G) into each, secure using the Allen wrench.

Align the front guard rail support (#9) to the other ends of the short guard rail (#8) and to the side of the upper side rail (#7). Insert bolts and nuts.

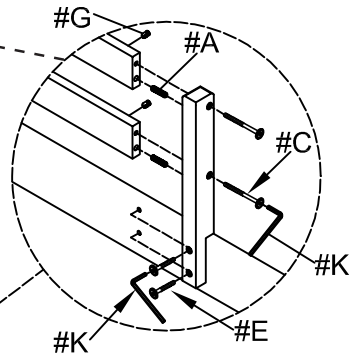

- #A x 4pcs
- #B x 6pcs
- #C x 2pcs
- #E x 2pcs
- #F x 3pcs
- #G x 8pcs

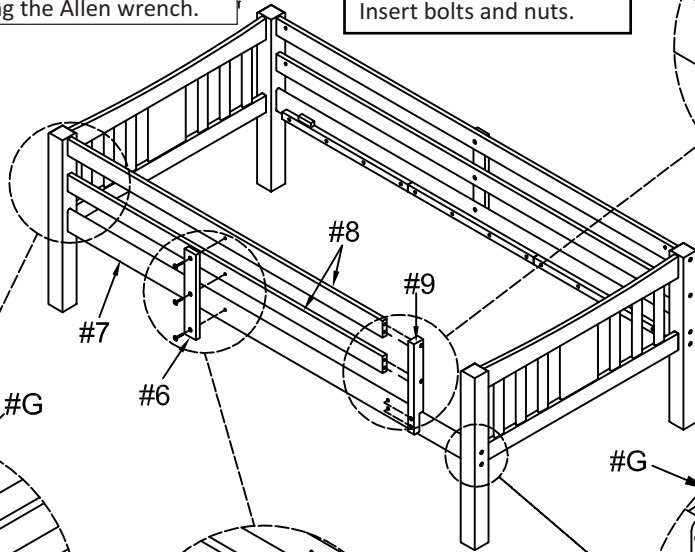

Align the upper side rail (#7) to the pre-drilled holes along the side of the upper headboard/footboard (#1/2). Insert 2 bolts (#B) and 2 barrel nuts (#G) secure using the Allen wrench.

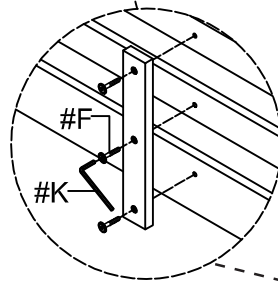
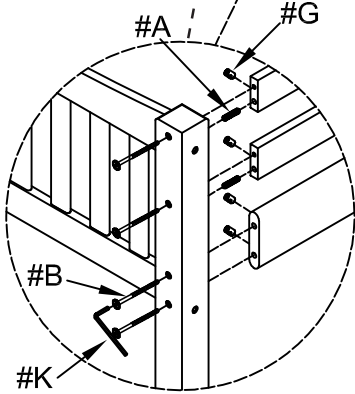

Align the vertical guard rail support (#6) to the center pre-drilled holes of (#7) and (#8). Then insert 3 bolts (#F) and secure using the Allen wrench.

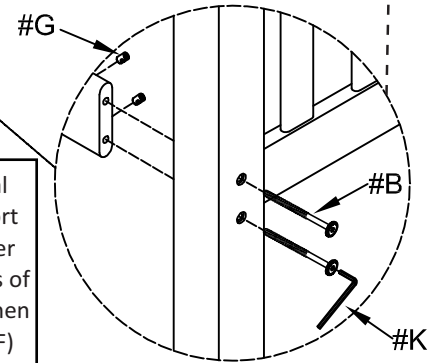

#4

#I x 4pcs

1. Insert a metal pin (#I) into the pre-drilled holes located on the top corners of the lower headboard & footboard.

2. With the help of another person, carefully place the top bunk bed onto the metal pins (#I).

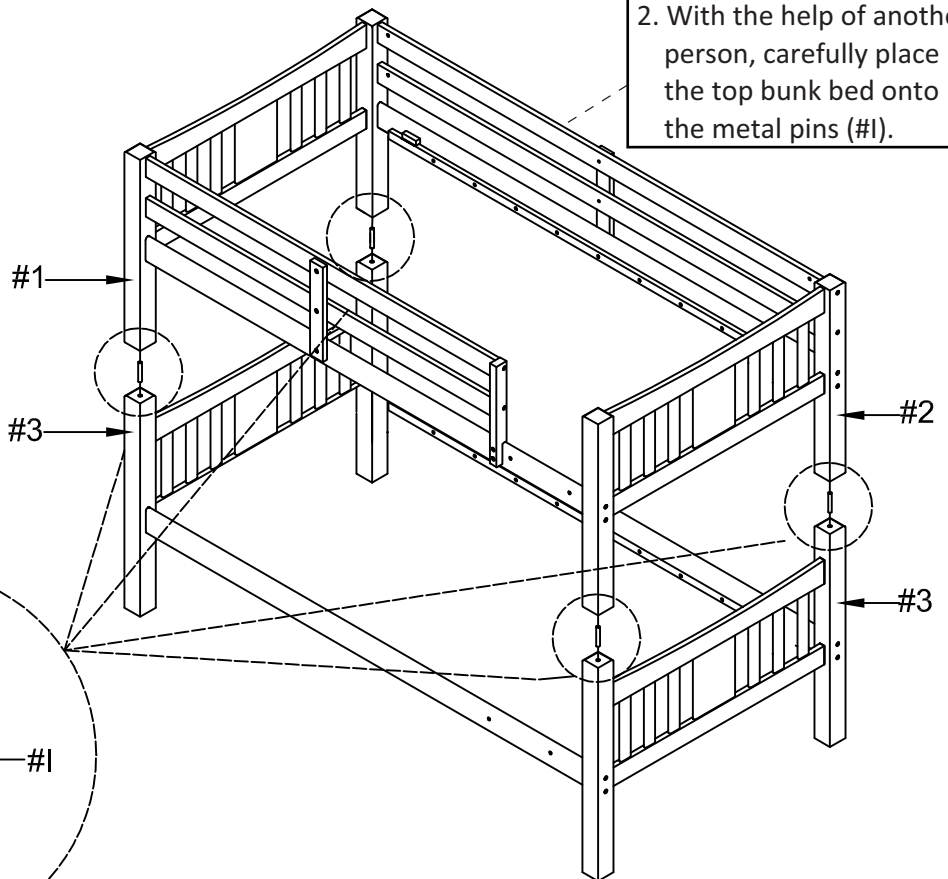
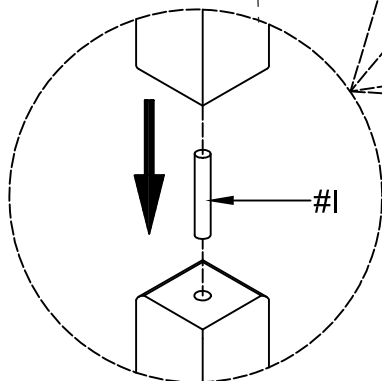



1. Insert a dowel (#A) into the larger pre-drilled holes on each end of the steps (#14). Align those ends of the steps (#14) to the slots along the sides of the left side rail ladder (#13) and right side rail ladder (#15). Then push dowels (#A) into those side rails.

#A x 8pcs
#H x 8pcs

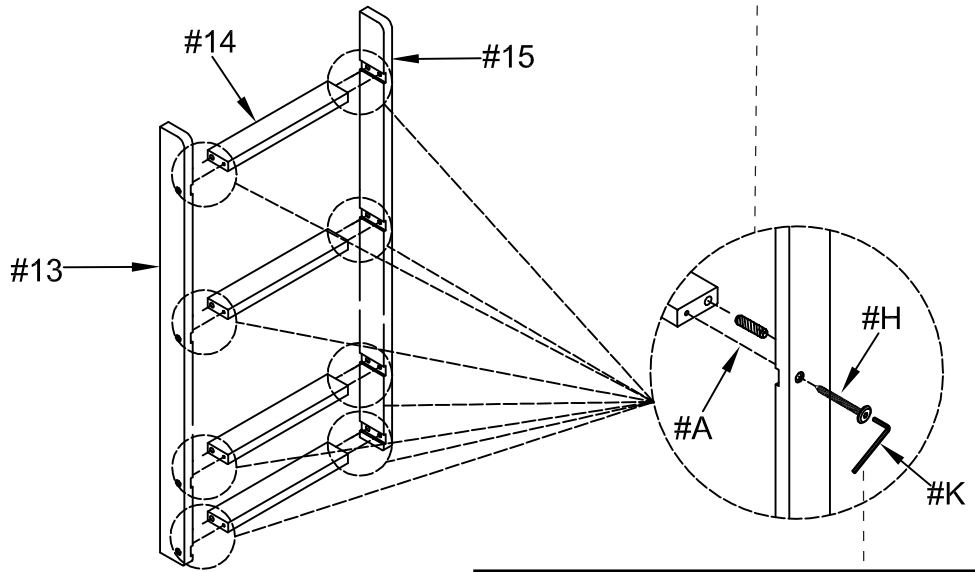

2. Insert a wood screw (#H) into each pre-drilled hole located along the outer sides of the side rails and secure using the Allen wrench (#K).



#D x 4pcs

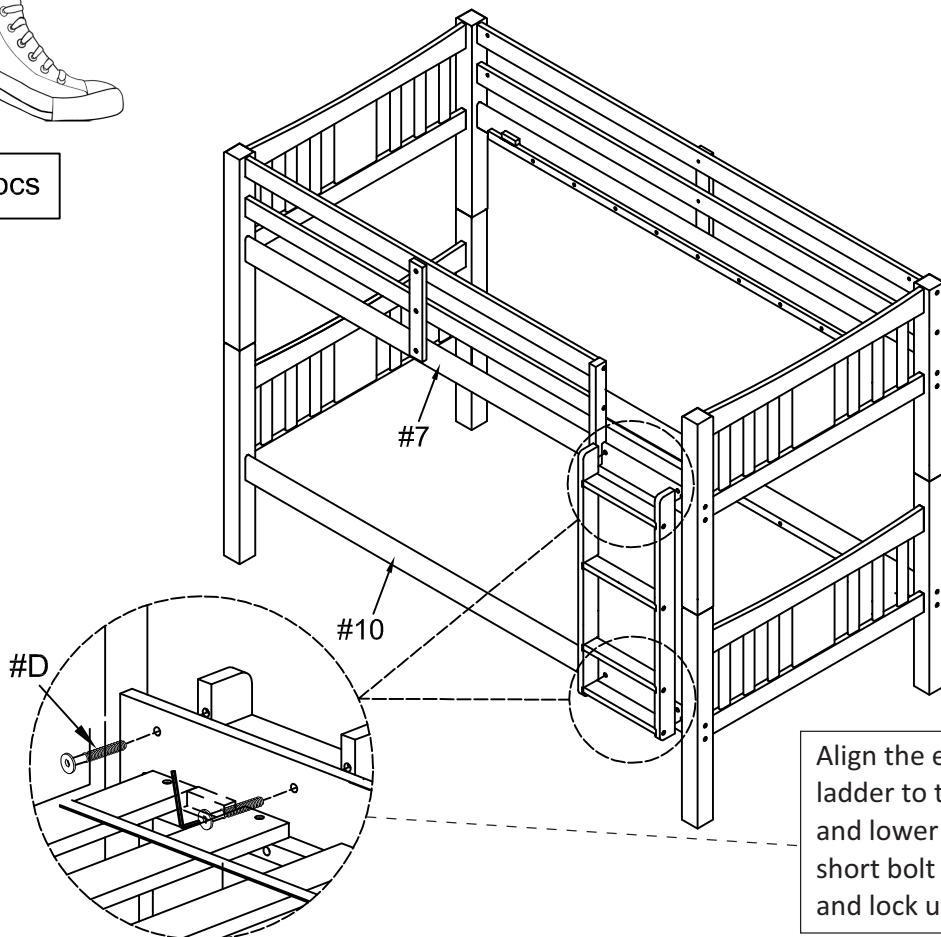

Align the ends of the completed ladder to the upper side rail (#7) and lower side rail (#10). Insert a short bolt (#D) from within the rails and lock using the Allen wrench (#K).



#J x 52pcs

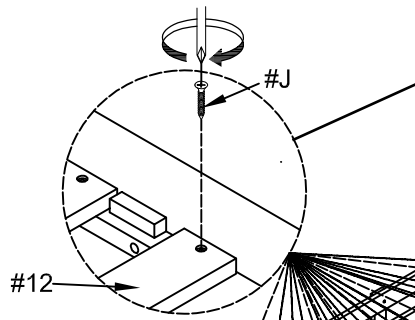

Align the ends of the upper slats (#12) to the pre-drilled holes along the inner side of the upper side rails. Insert a wood screw (#J) into each end and secure using a Phillips screwdriver.

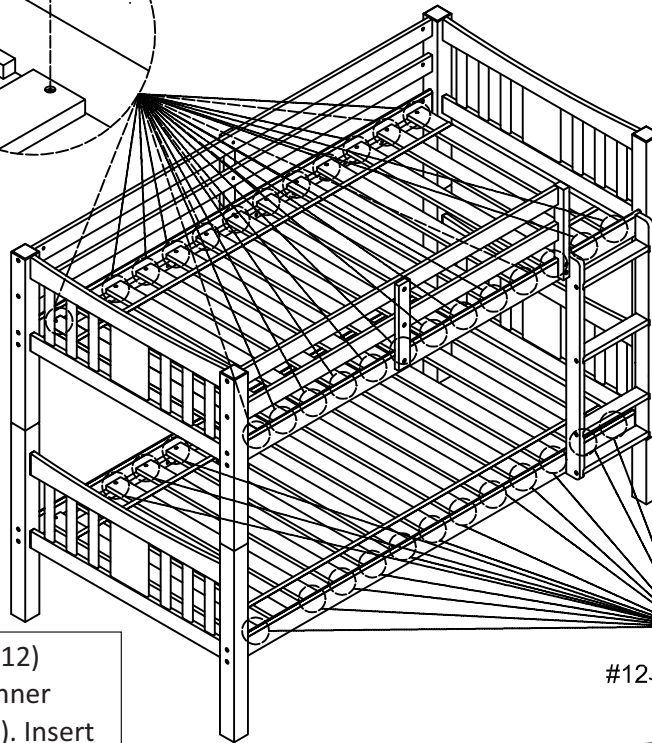

Align the ends of the lower slats (#12) to the pre-drilled holes along the inner side of the lower side rails (#10/11). Insert a wood screw (#J) into each end and secure using a Phillips screwdriver.

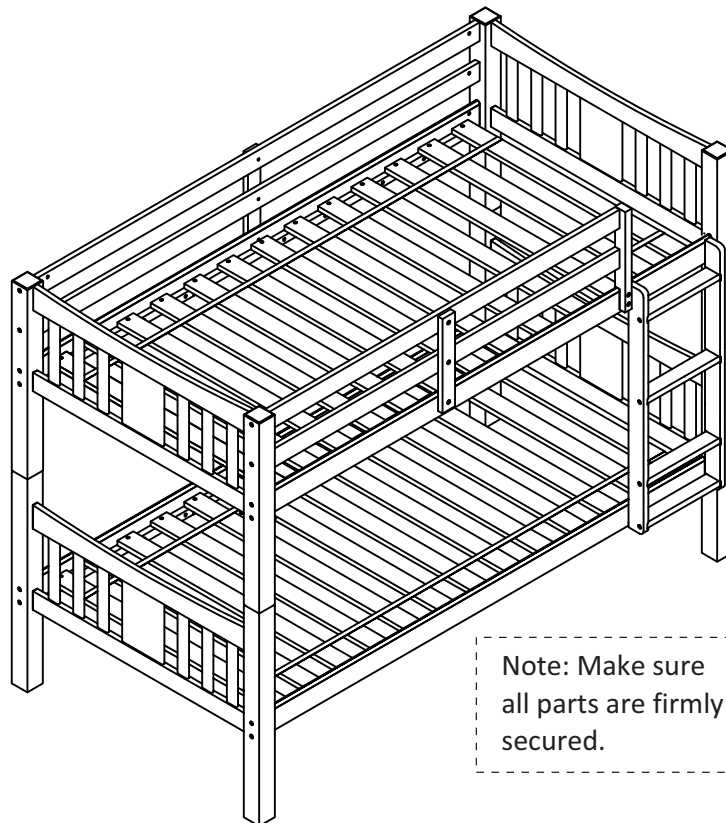
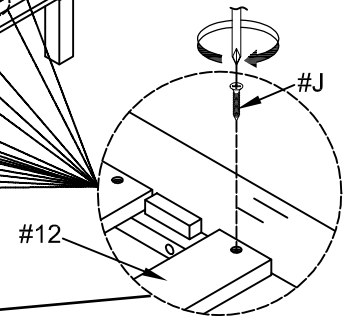

Note: Make sure all parts are firmly secured.

ASSEMBLY IS COMPLETED

Safety Warnings for Bunk beds

1. Read and follow the information on the WARNINGS shown on the end structure of the upper bunk and on the carton.
2. Do not remove warning label from the bed.
3. Keep these instructions for future reference.
4. **IMPORTANT: Must use Bunkie mattress or Bunkie board.** The proper sizes for the **UPPER/LOWER TWIN - SIZE** Bunkie mattress or Bunkie board should be 74" long and 37 $\frac{1}{2}$ " - 38 $\frac{1}{2}$ " wide with no more than 6" thickness and for the **UPPER/LOWER FULL- SIZE** should be 74" long and 53"-54" wide with no more than 8" thickness.
5. Surface of mattress must be at least 5 inches (127mm) **BELOW** the upper edge of guardrails.
6. The **MAXIMUM** weight capacity for the upper bunk is not to exceed 175 lbs.
7. Do not allow children under 6 years of age to use the upper bunk.
8. Periodically check and ensure that the guardrails, ladder, handle and other components are in their proper position, free from damage, and that all connectors are tightened and secured.
9. **DO NOT** allow horseplay, rough playing or jumping on the beds and do not allow playing or hiding under the beds.
10. Always use the ladder for entering or leaving the upper bunk.
11. Do not use substitute parts. Contact the manufacturer or dealer for replacement parts.
12. Use of a nightlight may provide added safety precaution for a person using the upper bunk.
13. Always use the guardrails on both sides of the upper bunk.
14. If the bunk bed will be placed next to a wall, the guardrail that runs the full length of the bed should be placed against the wall to prevent entrapment between the bed and the wall.
15. The use of water or sleep flotation mattresses is prohibited.
16. No more than one person is allowed on the upper bunk at all times.



WARNING: STRANGULATION HAZARD

Never attach or hang objects to any part of the bunk bed that are not designed for use with the bed. Objects such as hanger, hook, belt, bag, rope, string, etc. Should not be used on or around the bunk bed.