

# DINING CHAIR

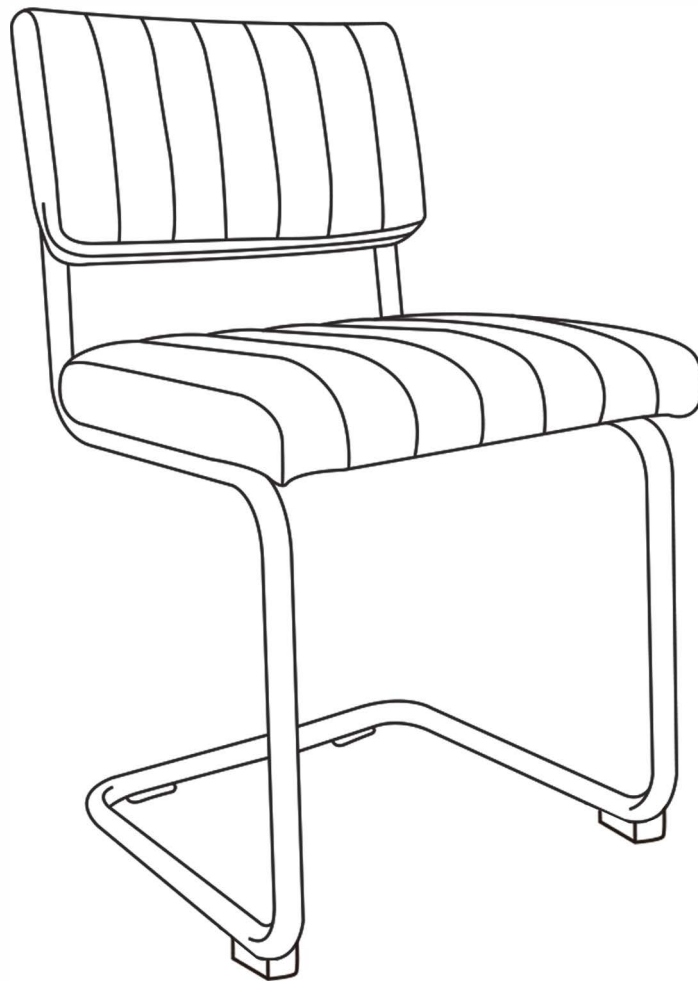

## ASSEMBLY INSTRUCTION

**HALF HOUR**  
ASSEMBLY TIME

**2 PEOPLE**  
REQUIRED FOR ASSEMBLY

**1 X 1 M**  
FLOOR SPACE REQUIRED

## SAFETY PRECAUTIONS







PLEASE READ ALL INSTRUCTIONS CAREFULLY BEFORE ASSEMBLING AND USING THE PRODUCT.

1. Please check all parts are present. You can prepare multi-function rechargeable screwdriver (not included) for Allen head screws to speed up your assembly.
2. For ease and speed of assembly. We recommend that you should identify all parts required for assembly before commencing each step.
3. Please ensure that you have sufficient space and people to assemble your product safely, perfectly on a flat surface.
4. We recommend that all assembled parts should be placed near from the assembly location to avoid loss or forgetting while assembling.
5. For larger items, we recommend that should be assembled where they are expected to be placed to minimize unnecessary movement.
6. It's recommended that the floor should be covered with cardboard or plastic to avoid damage.
7. In each step, do not tighten bolts/screws completely until all bolts/screws are lined up and tightened 80% separately. Do not over tighten bolts/screws to avoid stripping.
8. Do not stand on the product. Do not use the product as a step ladder.
9. This product is intended for indoor, household use, please do not put it outdoors on rainy days.

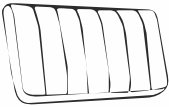
### Assembly tip!

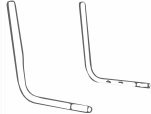
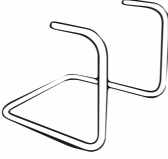
If it will seem like the holes on steel tubes don't line up with the cushion or the back at first but they do. You have to assemble one side and then have someone push the other side to line up with the cushion (or back) holes as you screw them in. This is what makes these chairs so sturdy!

## PARTS AND HARDWARE LIST

				 M6*40mm	 M6*45mm	
A*1	B*1	C*2	D*1	E*4	F*4	G*1

## ASSEMBLY STEPS

**Assembly tip:** If it will seem like the holes on steel tubes don't line up with the cushion or the back at first but they do. You have to assemble one side and then have someone push the other side to line up with the cushion (or back) holes as you screw them in. This is what makes these chairs so sturdy!

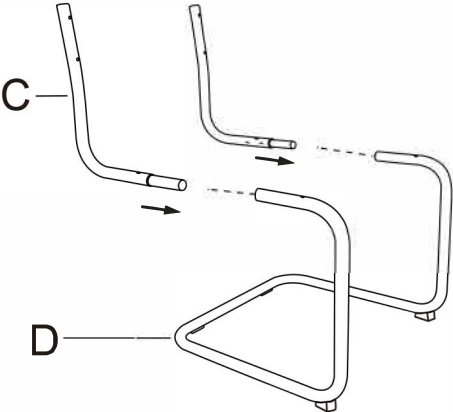
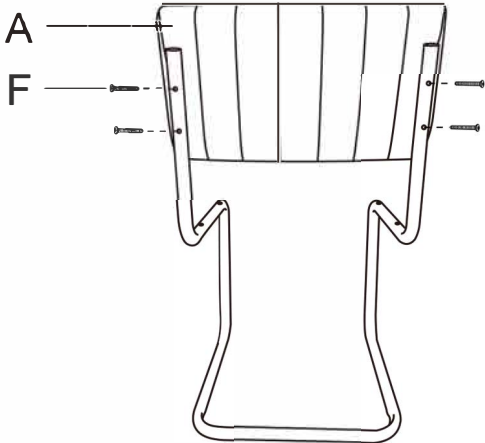
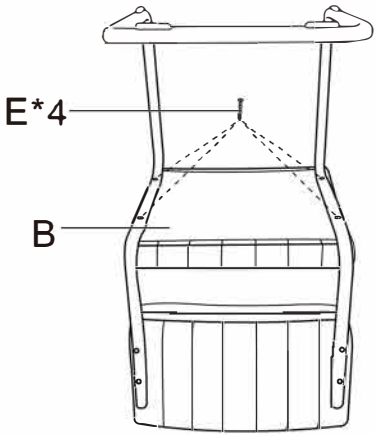
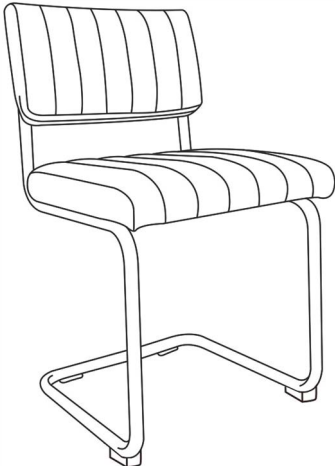
 <p><b>STEP 1.</b> Insert frame parts (C) into the holes of part (D) as shown.</p>	 <p><b>STEP 2.</b> All bolts/screws are lined up and inserted into the holes, attach back part (A) to the metal unit part (F) assembled as shown, secure it well by using bolt and wrench.</p>
 <p><b>STEP 3.</b> All bolts/screws are lined up and inserted into the holes, attach seat cushion (B) to the metal unit part (E*4) assembled as shown, secure it well by using bolt and wrench.</p>	 <p><b>STEP 4.</b> Finished chair</p>

## WARRANTY TERMS & CONDITIONS

1. We provide warranty for the product one year.
2. The warranty period starts on delivery date.
3. If the product has quality problem, contact us and we promise we will solve it for you.

## CORRECT SITTING POSITION

