

ASSEMBLY INSTRUCTIONS

DO NOT FULLY TIGHTEN SCREWS AND BOLTS UNTIL THE ENTIRE ITEM IS COMPLETELY ASSEMBLED

PART LIST

(A) Back Assembly
(1pc)

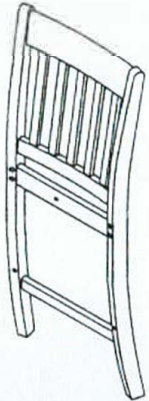

(B) Seat Assembly
(1pc)

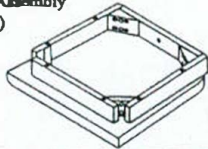

(C) Front Leg - Left & Right (2pcs)

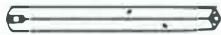

(D) Front Stretcher
(1pc)



(E) Side Stretcher - Left
(1pc)



(F) Side Stretcher - Right
(1pc)



HARDWARE LIST

Long Bolt



(1) $\varnothing 1/4" \times 75\text{mm}$
(4pcs)

Medium Bolt



(2) $\varnothing 1/4" \times 60\text{mm}$
(4pcs)

Short Bolt



(3) $\varnothing 1/4" \times 40\text{mm}$
(1pc)

Flat Washer



(4) $\varnothing 1/4" \times 19\text{mm}$
(9pcs)

Spring Washer



(5) $\varnothing 1/4" \times 13\text{mm}$
(9pcs)

Allen Key



(6) 4 mm (1pc)

Wood Screw



(7) $\varnothing 4\text{mm} \times 38\text{mm}$
(6pcs)

TOOL REQUIRED



Screw Driver (Not Provided)

Step 1

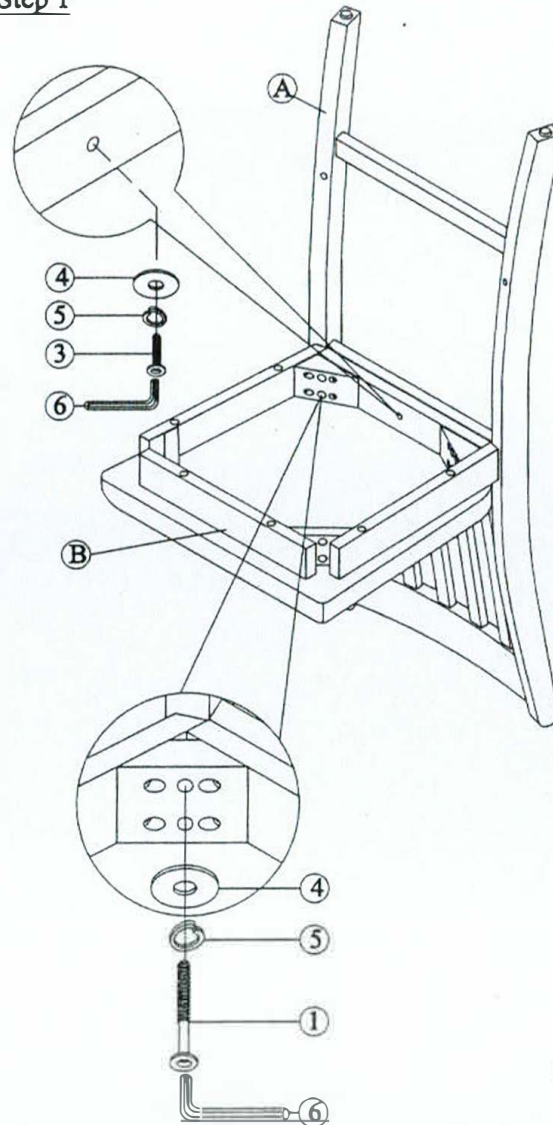

Step 2

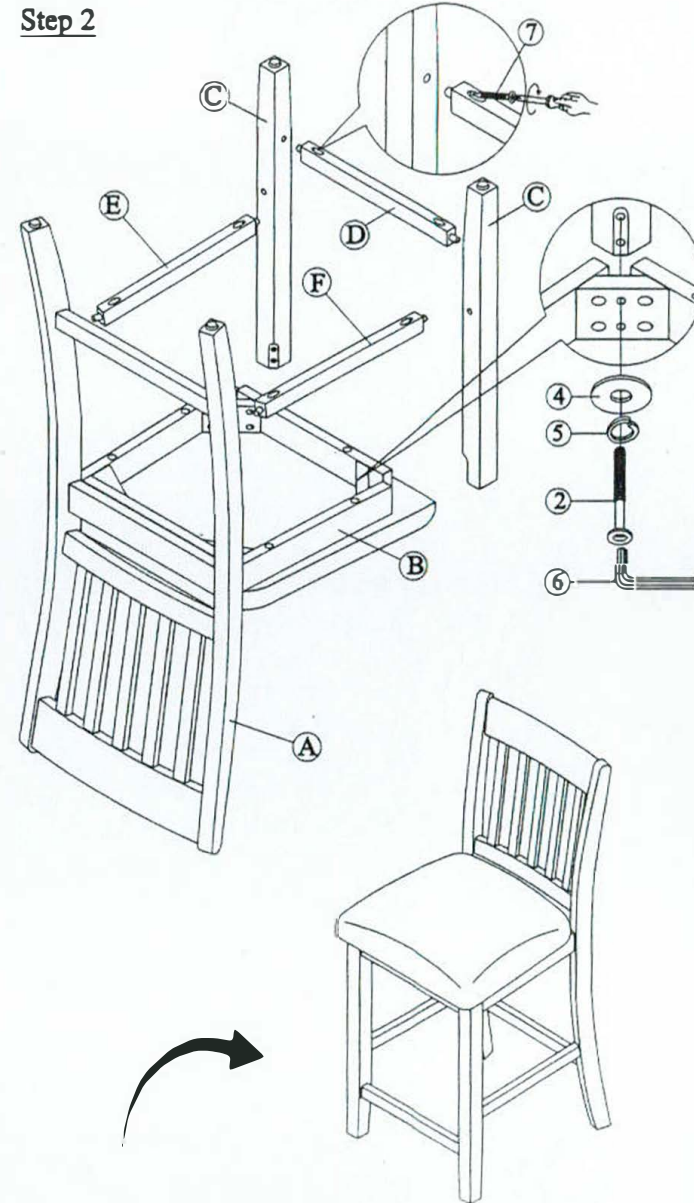

ASSEMBLY INSTRUCTIONS

DIMENSIONS :
L42" x W42" x H.36"

PART LIST

(A) 1pc
Top Assembly

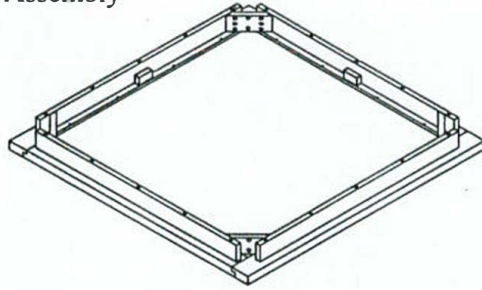

(B) 4pcs
Leg

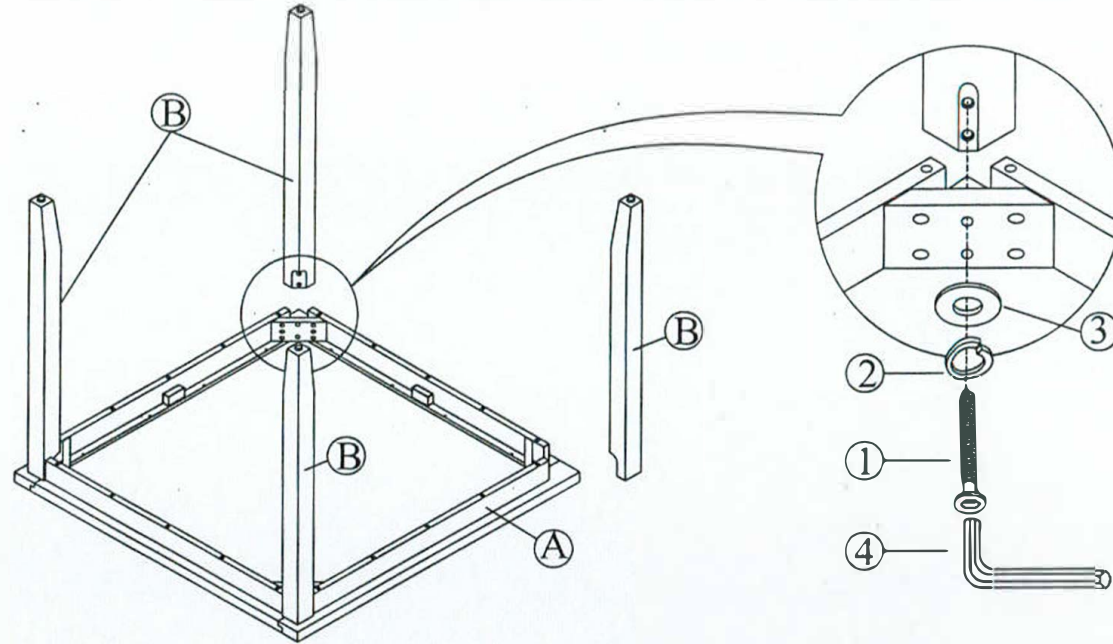

HARDWARE LIST

TEAR OFF THE PLASTIC PROTECTIVE FILM ON TABLE TOP WITH GENTLY

Hex Nut



(1) Ø5/16" x 70mm
(8pcs)

Spring Washer



(2) Ø5/16" x 13mm
(8pcs)

Flat Washer



(3) Ø5/16" x 19mm
(8pcs)

Allen Key



(4) 4mm (1pc)

