

Assembly Instructions

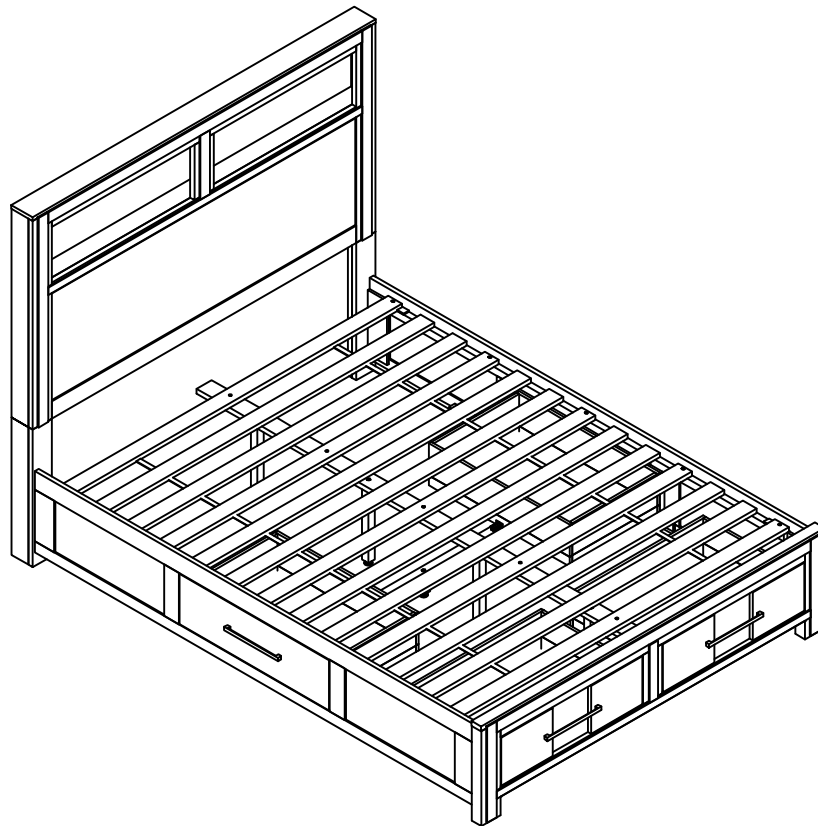

ASSEMBLY RATING

The Assembly Rating is a 5-point system that shows the degree of effort needed in assembling a specific product (with 1 being easy and 5 being difficult). For some products, two persons are recommended.

EASY  DIFFICULT

Tools Required For Assembly:

Allen Wrench

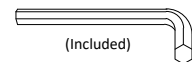

Phillips Screwdriver

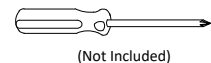

2 PERSONS RECOMMENDED

ASSEMBLY & CARE ADVICE

FOR YOUR FURNITURE TO LAST, CORRECT ASSEMBLY AND PROPER MAINTENANCE ARE NECESSARY. PLEASE FOLLOW THE INFORMATION PROVIDED BELOW TO FULLY ENJOY YOUR FURNITURE.

BASIC ASSEMBLY TECHNIQUES

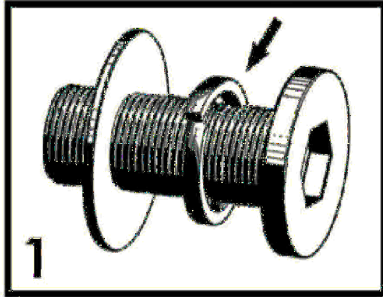

1
When lock or spring washer is used in an assembly, please make sure the lock or spring washer is placed between the larger flat washer and the head of the screw or bolt.

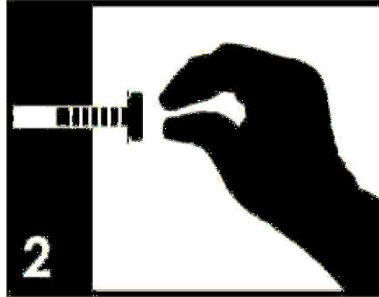

2
Position each part correctly and insert screws or bolts into their respective holes by hand tighten or using the proper hand tool. Only tighten when step is completed or when instructed to do so.

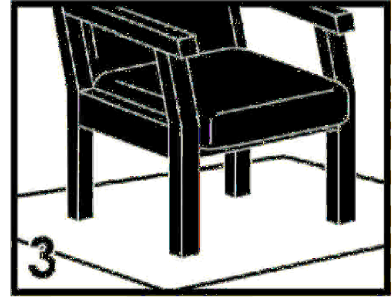

3
Use cardboard or carpet area when assembling furniture to prevent scratches. Make sure the furniture rests on a flat and level surface with each leg evenly touching the floor.

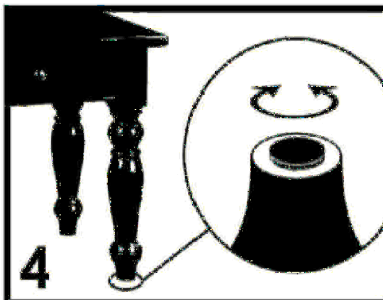

4
Some furniture comes with height adjustment knobs underneath each leg. To lower or to raise each leg, you need to turn clockwise or counterclockwise, respectively.

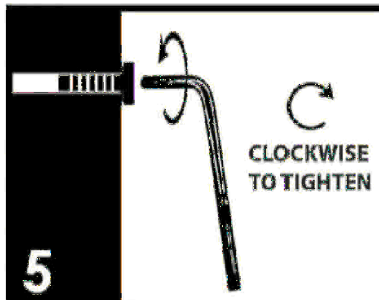

5
Make sure all parts are properly aligned, then use the appropriate hand tool to completely tighten the bolts or screws. Do not use power tools and do not overtighten.

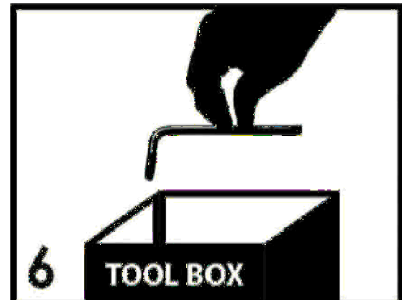

6
Save the instructions and store the Allen wrench or any supplied tool for later maintenance. After two weeks, check and tighten any loose hardware and repeat again every six months thereafter.

IT IS THE USER'S RESPONSIBILITY TO MAINTAIN THE FURNITURE. THE HARDWARE MAY LOOSEN OVER TIME AND MAY CAUSE THE FURNITURE TO BE WOBBLY AND UNABLE TO SUPPORT ITS INTENDED WEIGHT CAPACITY. THIS MAY LEAD TO COLLAPSE AND MAY CAUSE SERIOUS INJURY.



FAILURE TO FOLLOW THE GUIDELINES ABOVE MAY RESULT IN INJURY AND/OR PROPERTY DAMAGE.

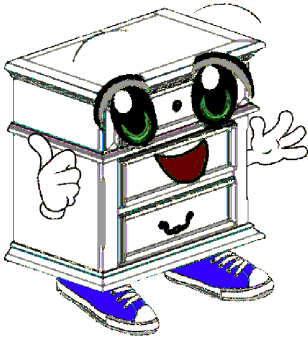

Before you begin, please read Page 2 of "Assembly and Care Advice".

And remember, do not tighten until each step is completed or instructed.

Parts List

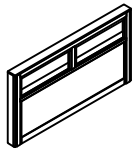

#1 x 1pc
Headboard

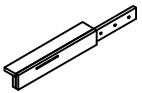

#2 x 2pcs
Headboard Leg(L&R)

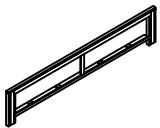

#3 x 1pc
Footboard

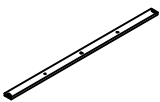

#4 x 1pc
Footboard Drawer Support Slat



#5 x 1pc Ø5/16"
Footboard Drawer Support Leg
65x30x30mm



#6 x 2pcs
Drawer Slide Rail

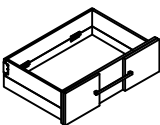

#7 x 2pcs
Footboard Drawer

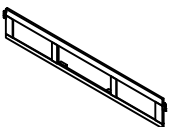

#8 x 2pcs
Side Rails

Hardware List

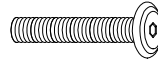

#A x 6pcs
Bolt Ø5/16" x 1-3/8"



#B x 6pcs
Lock Washer Ø5/16"

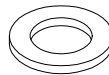

#C x 14pcs
Flat Washer Ø5/16"



#D x 1pc
Allen key M4



#E x 8pcs
Bolt Ø1/4" x 1-5/8"



#F x 8pcs
Lock washer Ø1/4"



#G x 17pcs
Screw #4 x 30mm



#H x 24pcs
Screw #4 x 10mm

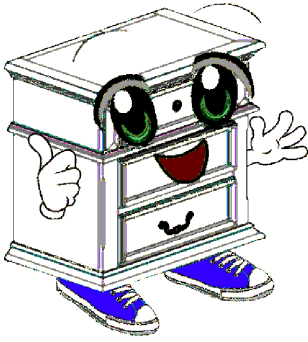

Before you begin, please read Page 2 of "Assembly and Care Advice".

And remember, do not tighten until each step is completed or instructed.



#9 x 1pc
Rail Drawer Support Slat

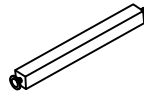

#13 x 4pcs Ø5/16"
Slat support leg 310x30x30mm



#10 x 1pc Ø5/16"
Rail Drawer Support Leg
60x30x30mm

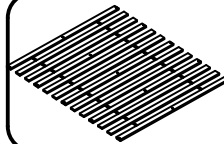

#14 x 1set
Slat (13 pcs)

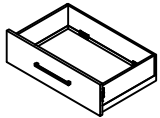

#11 x 2pcs
Rail Drawer



#12 x 1pc
Center Support

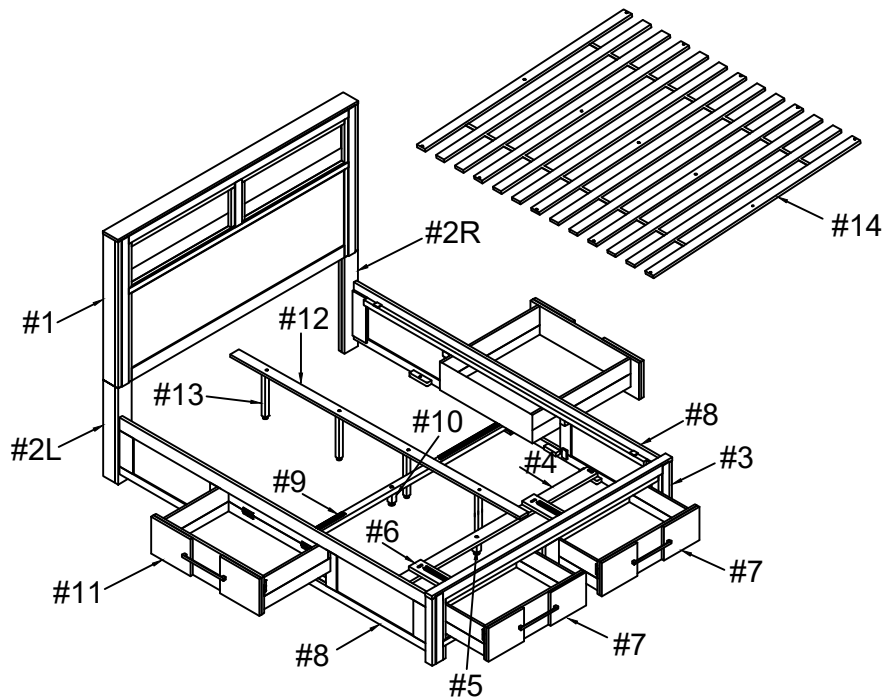



#1

Prepare 6 bolts assembly by inserting lock washer (#B), then flat washer (#C) onto bolts (#A). Align HB legs (#2R/L) to the holes of the headboard (#1). Secure by using bolts (#A).

#A x 6pcs
#B x 6pcs
#C x 6pcs

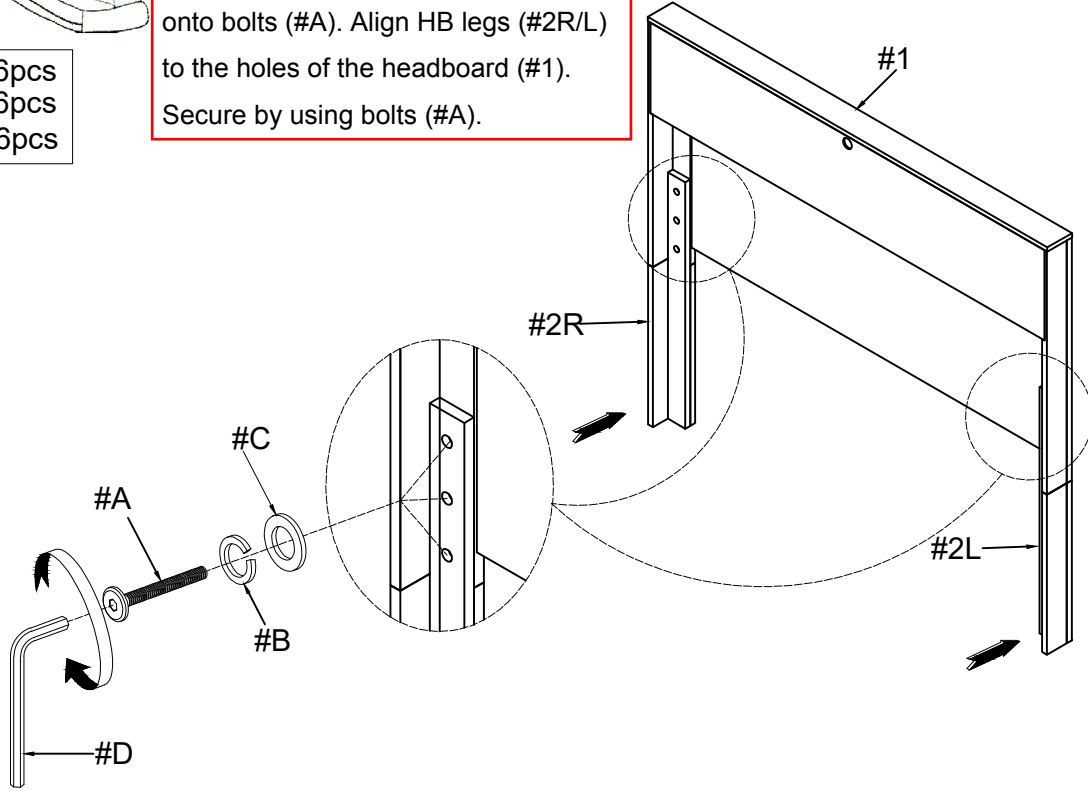

#2

Align and hook the side rails (#8) to the latch of the headboard (#1) and footboard (#3). Make sure it is firmly in place.

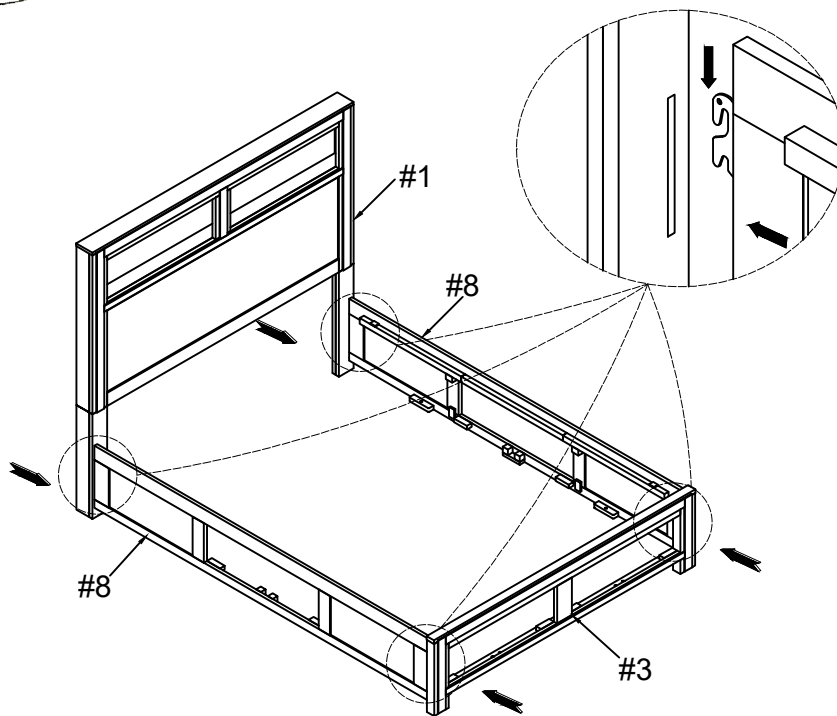



Attach support legs (#5) to the holes of the support slat (#4). Adjust the leveler on the support legs (#5) according to ground level.

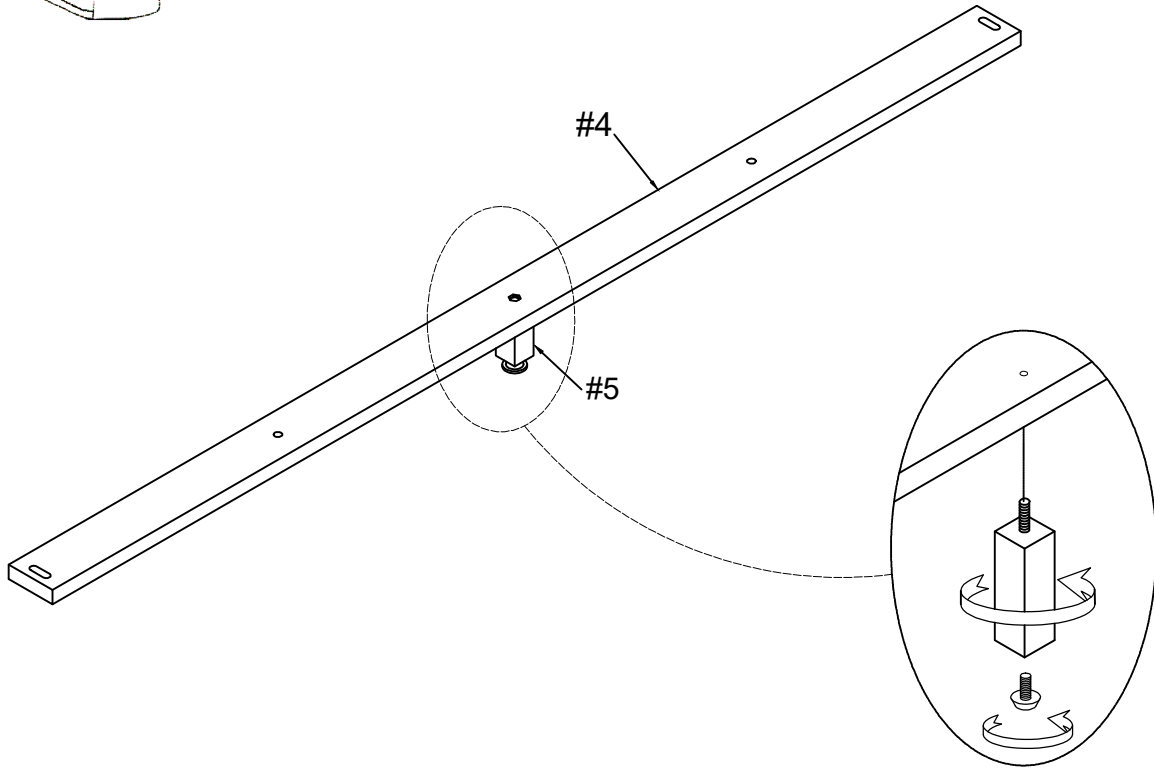

#E x 2pcs
#F x 2pcs
#C x 2pcs

Prepare 2 bolts assembly by inserting lock washer (#F), then flat washer (#C) onto bolts (#E). Align support slat (#4) to the side rails (#8), then secure by using bolts (#E).

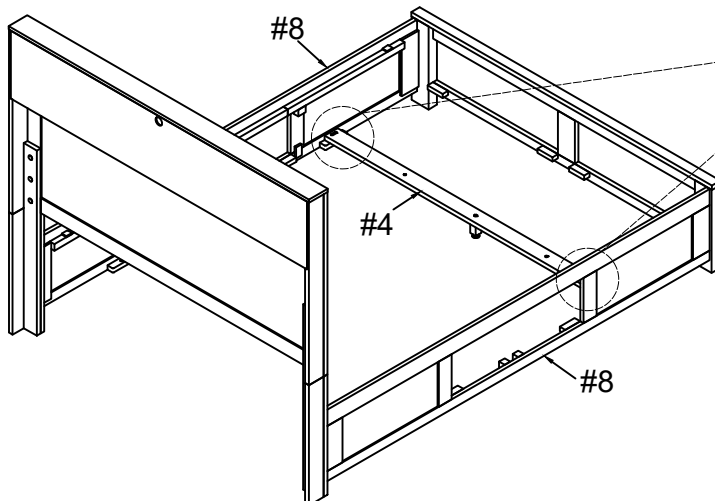
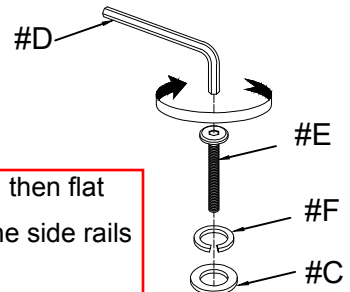



#E x 6pcs
 #F x 6pcs
 #C x 6pcs

Prepare 6 bolts assembly by inserting lock washer (#F), then flat washer (#C) onto bolts (#E). Align drawer rails (#6) to the holes of the footboard (#3) and support slat (#4). Secure by using bolts (#E).

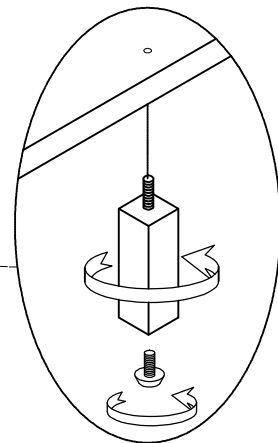
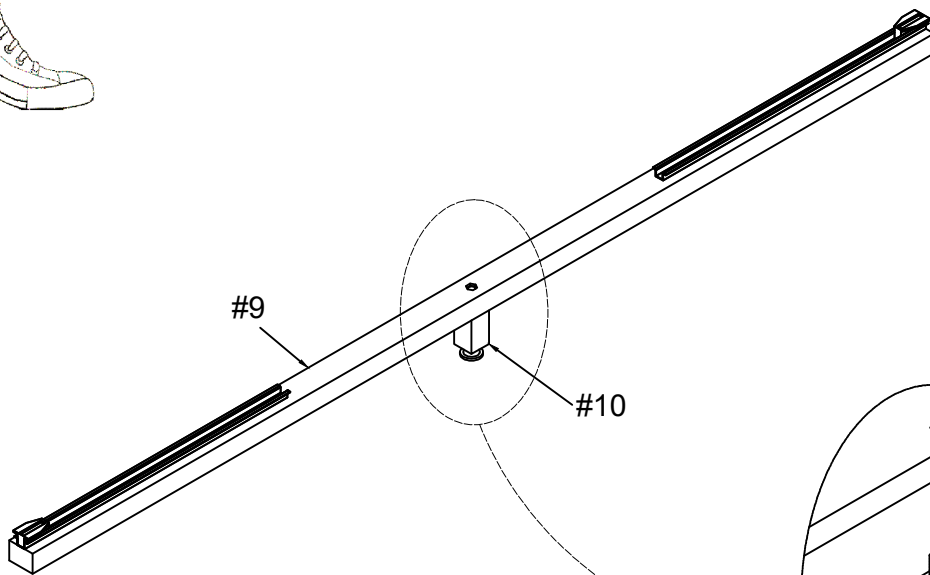
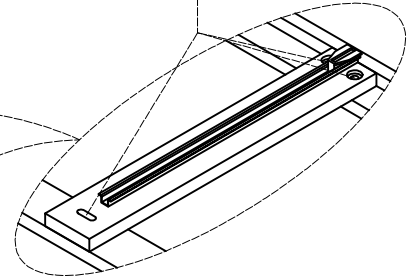
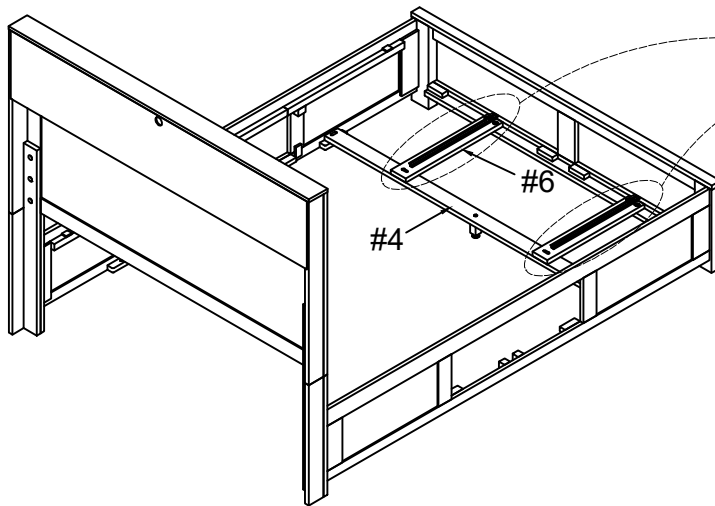
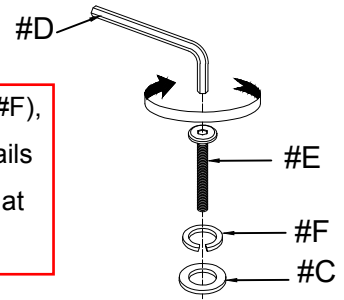

Attach support leg (#10) to the hole of the drawer support slat (#9).
 Adjust leveler of the support leg (#10) according to ground level.



#7

Align drawer support slat (#9) to the side rails (#8), then secure by using screws (#G).

#G x 2pcs

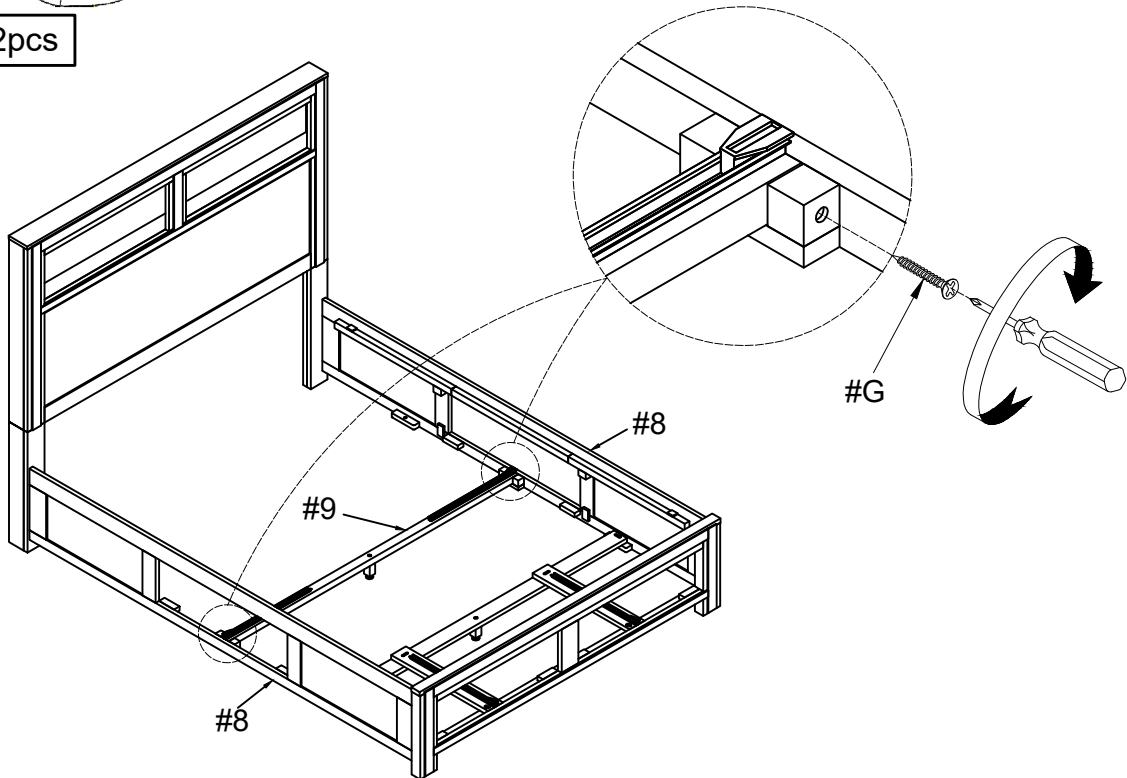

#8

Align and attach support legs (#13) to the holes of the center support (#12). Adjust the levelers of the support legs (#13) according to ground level.

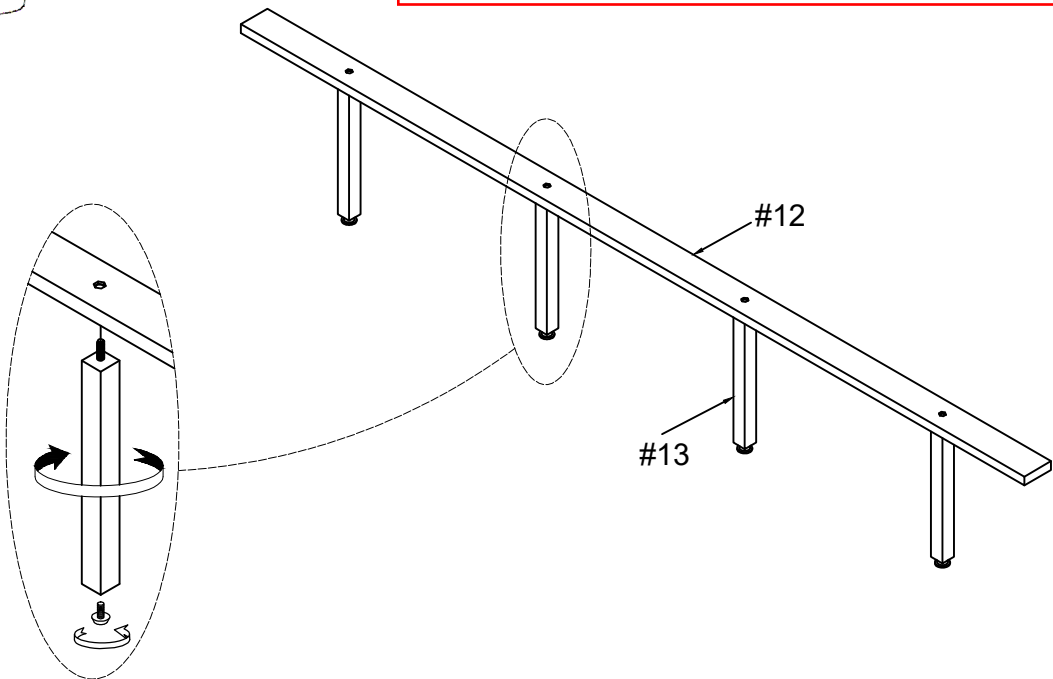



#9

Align slats (#14) to the side rails (#8), then secure by using screws (#G).

#G x 15pcs

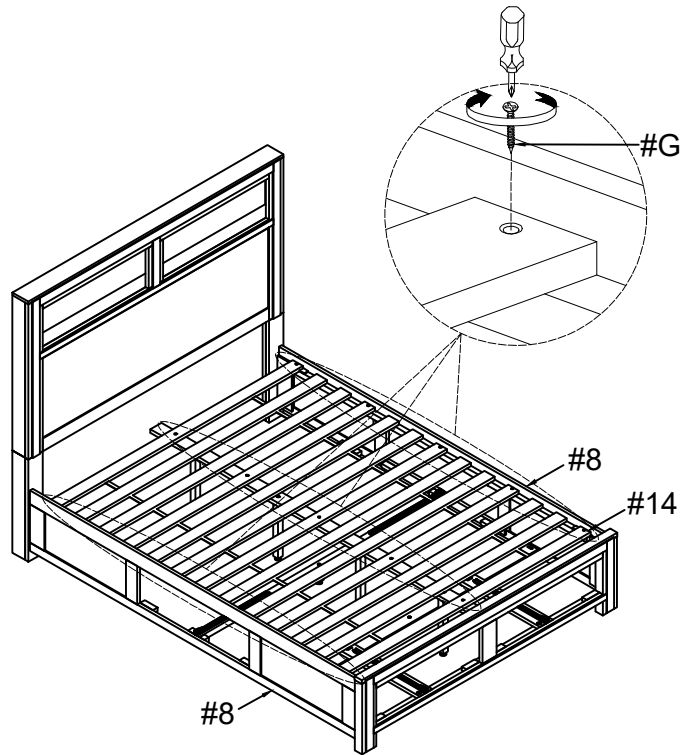

#10

Unfold the drawers (#7,11), then secure the drawers (#7,11) by using screws (#H)

#H x 6pcs

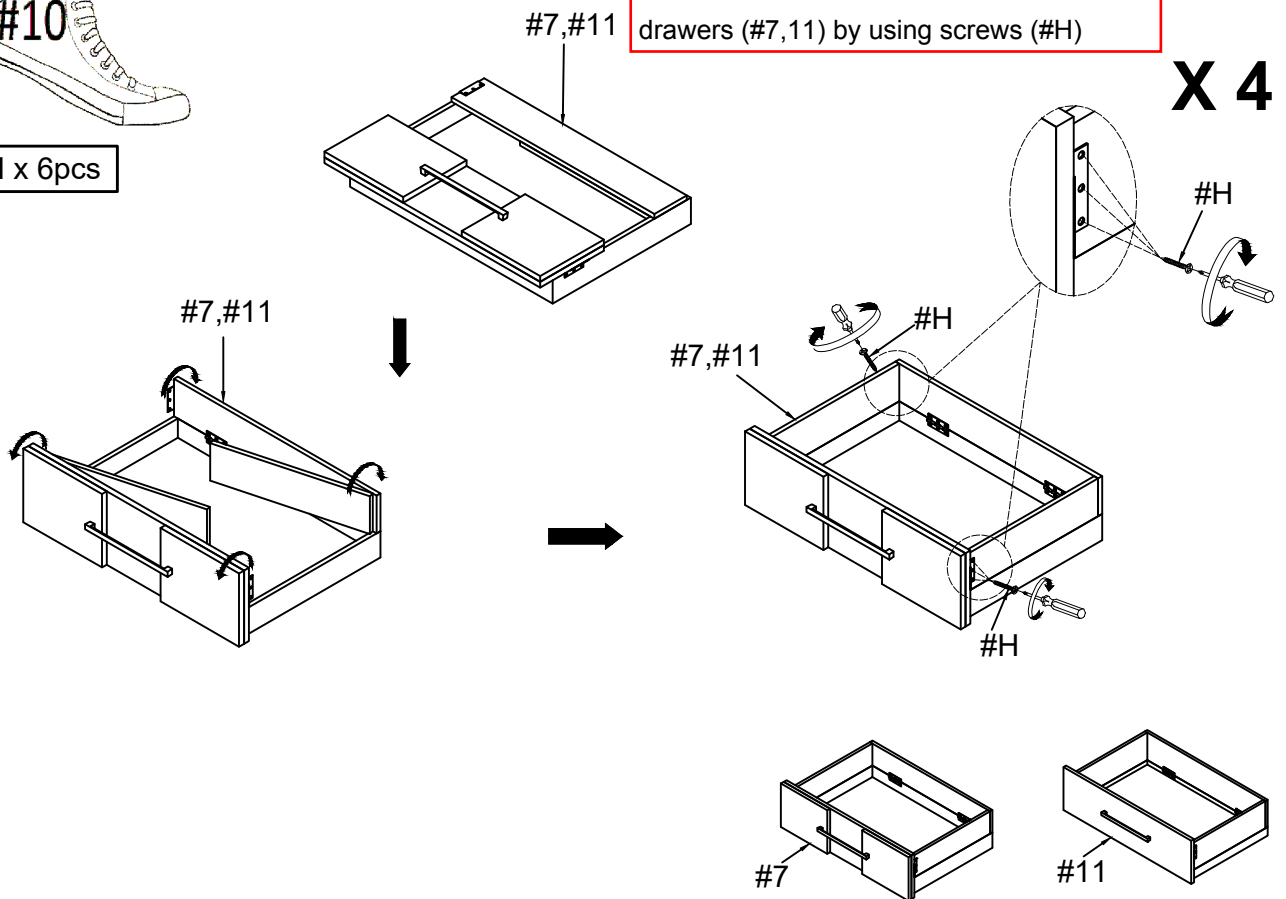

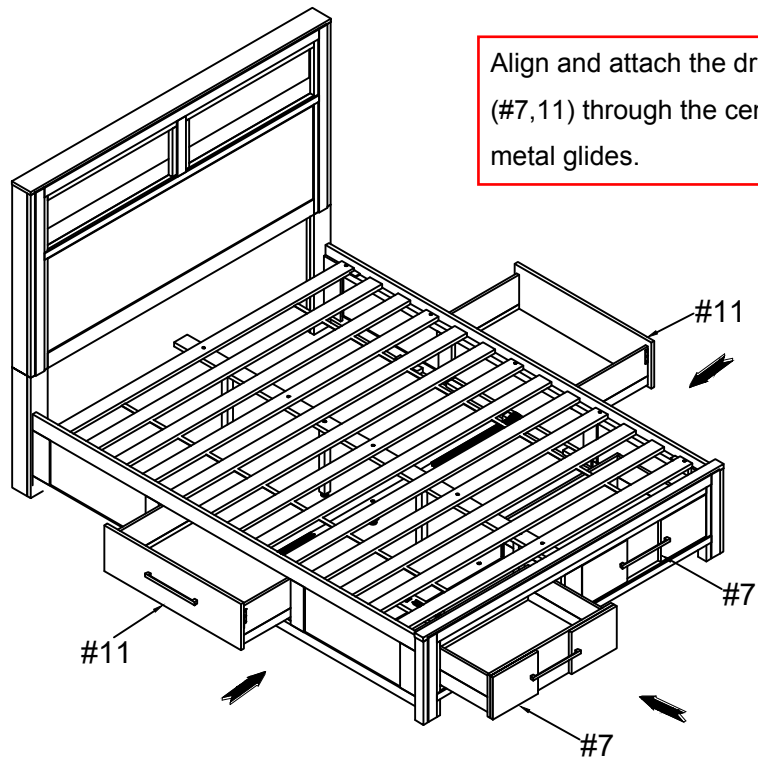

Align and attach the drawers (#7,11) through the center metal glides.

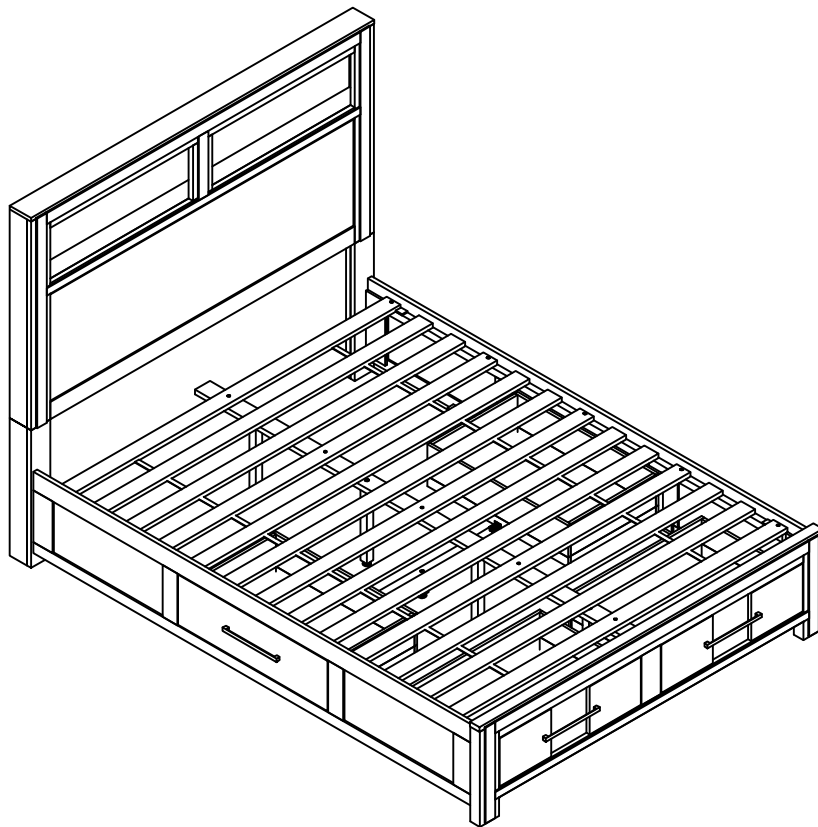

ASSEMBLY IS COMPLETED