

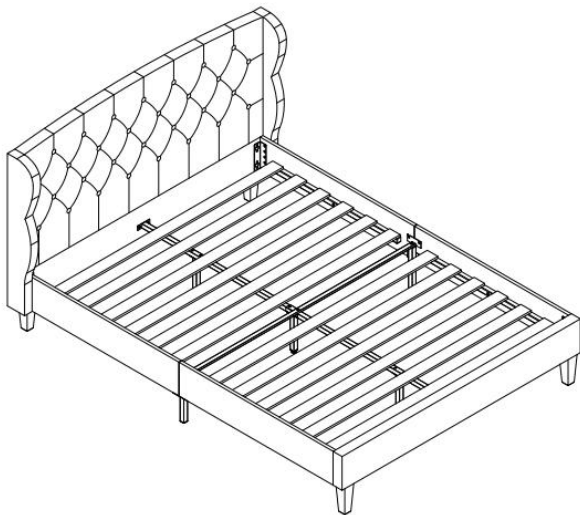









QUEEN BED

Before you start, here are some helpful advice:

1. We suggest you spend a short time reading through this leaflet and then follow the simple step-by-step instructions.
2. Owing to the size and weight of the bed, we recommend that it is assembled by two adults, on a carpeted or padded area, in the room that it is intended for. Approximate assembly time: 30 minutes.
3. Please do not use any tools other than those provided or recommended in these instructions.
4. Please do not throw away any of the packaging or the instruction until you have checked all the components and hardware and the furniture is fully assembled. Please ensure that the packaging is disposed of in a safe and environmentally friendly way.
5. Assemble all components loosely until advised to tighten. Depending on use, it may be necessary to tighten the components from time to time, so please save the tools that have been provided.
6. Please keep all the fitting out of reach of children.



Hardware:

A.		Bolt M8x20mm	x18
B.		Bolt M8x25mm	x12
C.		Bolt M8x45mm	x9
D.		Bolt M8x60mm	x1
E.		Nut M8	x6
I.		Connection plate	x4
J.		Flat Washer	x4
L.		Allen Wrench	x1
M.		Spanner Wrench	x1

Components:

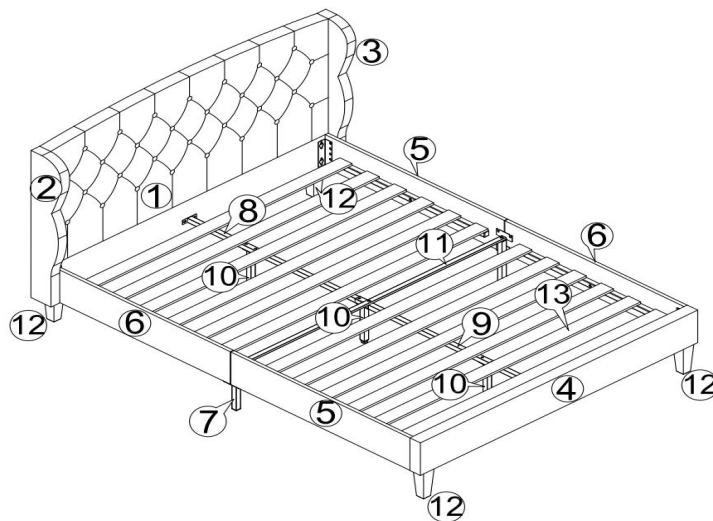

1. Headboard	x1	2. Left Ear	x1	3. Right Ear	x1	4. Footboard	x1	5. Side Rail	x2
6. Side Rail	x2	7. Side Support Leg	x2	8. Center Cross -back	x1	9. Center Cross -front	x1		
10. Center Support Leg	x3	11. Cross Bar	x1	12. Leg	x4	13. Slats	x2		

QUEEN BED

STEP 1:

1. Attach **Left Ear (2)** to the left of the **Headboard (1)** by using 2 pieces of **Bolts (C)** from back as shown.
2. Repeat the same step to assemble **Right Ear (3)** to the **Headboard (1)** as shown.
3. Use **Allen Wrench (L)** to tighten all **Bolts (C)** clockwise as shown.
4. Tighten 2 pieces of **Legs (12)** to the bottom of **Headboard (1)** with 2 pieces of **Flat washers (J)** clockwise until secure by hand as shown.
5. Repeat the same step to assemble 2 pieces of **Legs (12)** to the **Footboard (4)**.

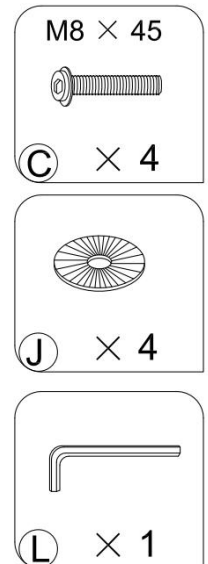
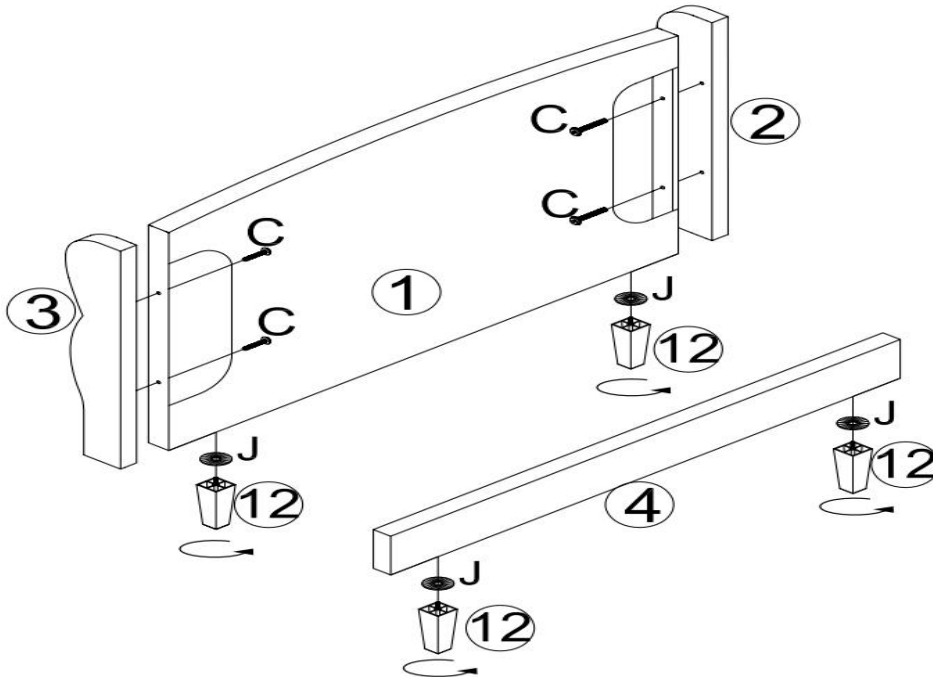

Hardware & Tools required

STEP 2:

1. Attach the 2 pieces of **Side Rails (5)** to the 2 pieces of **Side Rails (6)** by using 2 pieces of **Side Support Legs (7)** with 8 pieces of **Bolts (A)** as shown
2. Attach 2 pieces of **Connection plates (I)** to 2 pieces of **Side Rails (5)** by using 4 pieces of **Bolts (A)** as shown.
3. Attach 2 pieces of **Connection plates (I)** to 2 pieces of **Side Rails (6)** by using 4 pieces of **Bolts (A)** as shown.
4. Use **Allen Wrench (L)** to tighten all **Bolts (A)** clockwise as shown.

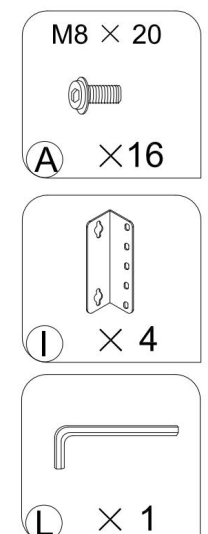
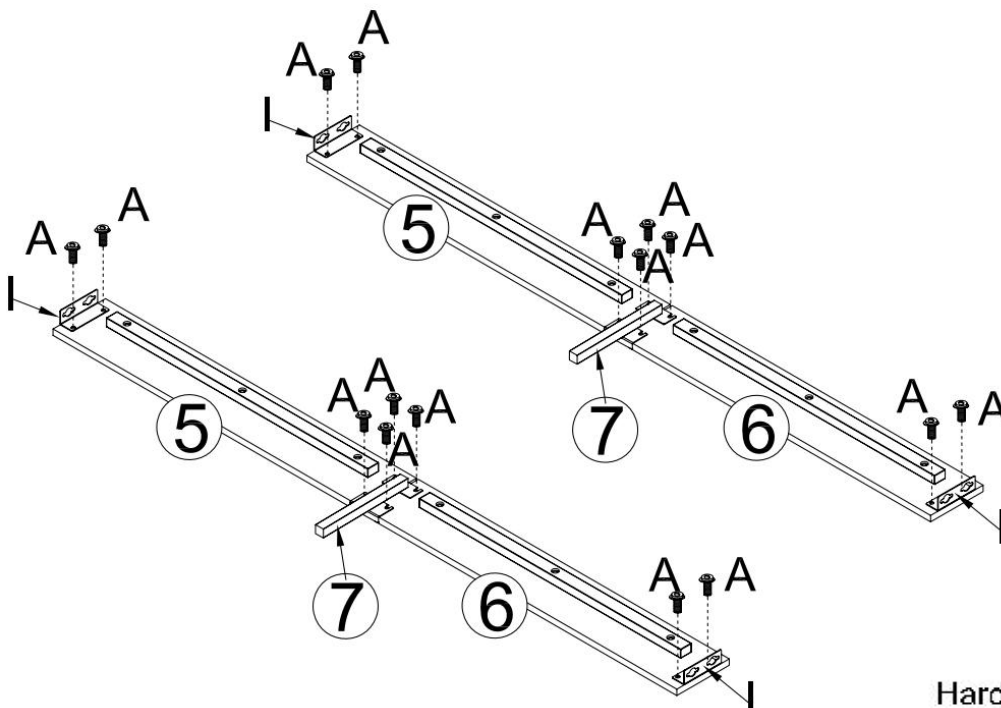

Hardware & Tools required

QUEEN BED

STEP 3:

1. Attached the 2 pieces of assembled **Side Rails (5&6)** to the **Headboard (1)** and **Footboard (4)** by using 4 pieces of **Bolts (B)** as shown.
2. Use **Allen Wrench (L)** to tighten all **Bolts (B)** clockwise as shown.

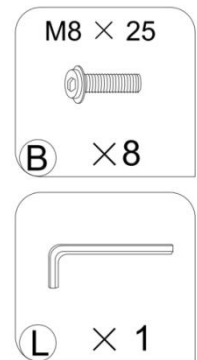
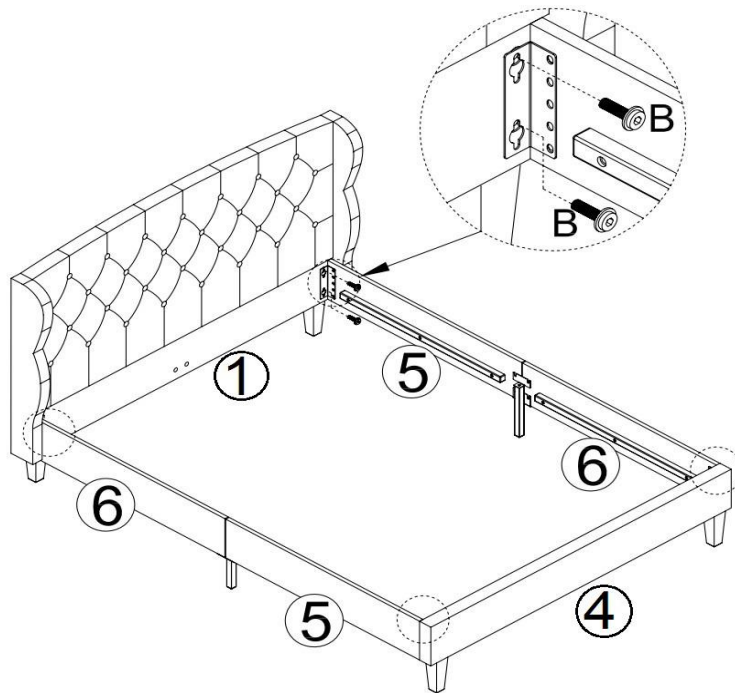

Hardware & Tools required

STEP 4:

1. Attach one of the leg of the **Center Support Leg (10)** to the **Center Cross-Front (9)** and the **Cross Bar (11)** by using 1 piece of **Bolt (D)** and **Bolt (C)** then affix 2 pieces of **Nuts (E)** on each bolt as shown.
2. Attach the other legs on each end of the **Center Cross-Front (9)** and **Center Cross - Back (8)** by using 2 pieces of **Bolt (C)** then affix 2 pieces of **Nuts (E)** on each bolt as shown."
3. Use **Allen Wrench (L)** and **Spanner Wrench (M)** to tighten all **Bolts (C&D)** and **Nuts (E)** clockwise as shown.

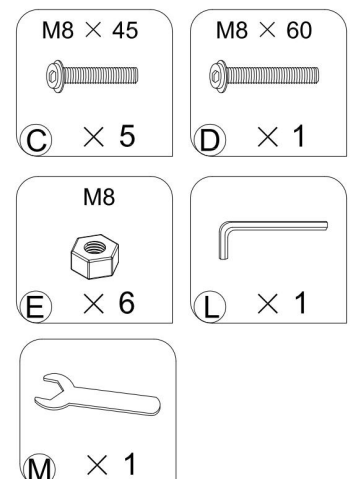
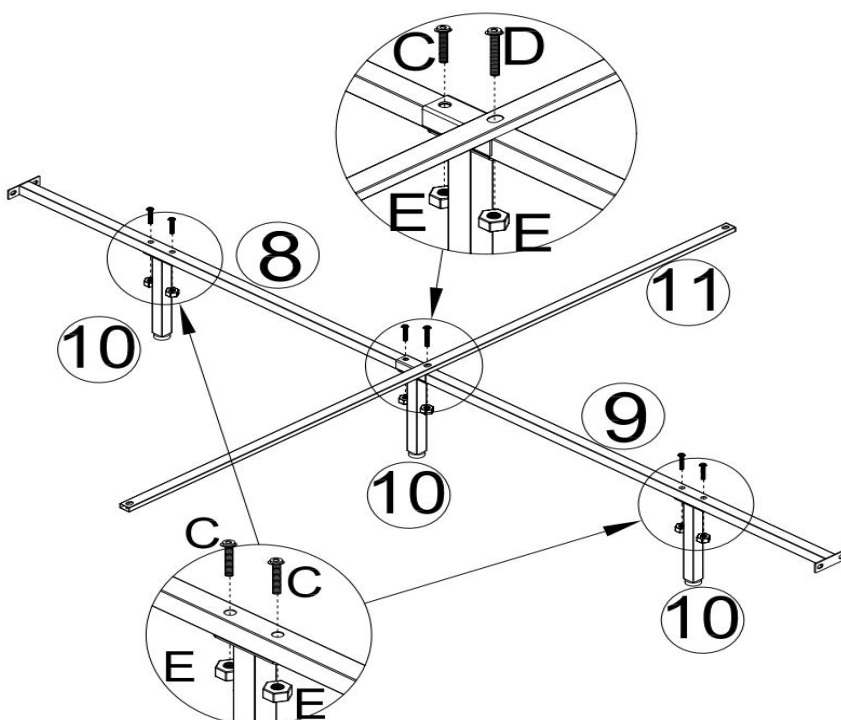

Hardware & Tools required

QUEEN BED

STEP 5:

1. Put the assembled Cross Center & Cross Bar from step 4 to the assembled Side Rails from step 3.
2. Attach **Center cross-back (8)** to the **Headboard (1)** by using 2 pieces of **Bolts (B)** as shown.
3. Attach **Center cross-front (9)** to the **Footboard (4)** by using 2 pieces of **Bolts (B)** as shown.
4. Attach **Cross bar (11)** to the 2 pieces of **Side Rails (5 & 6)** by using 2 pieces of **Bolts (A)** as shown.
5. Use **Allen Wrench (L)** to tighten all **Bolts (A)** and **Bolts (B)** clockwise as shown.

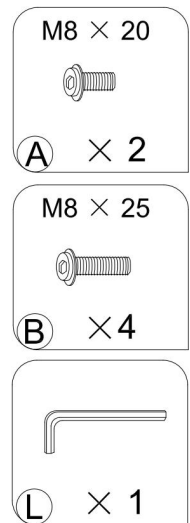
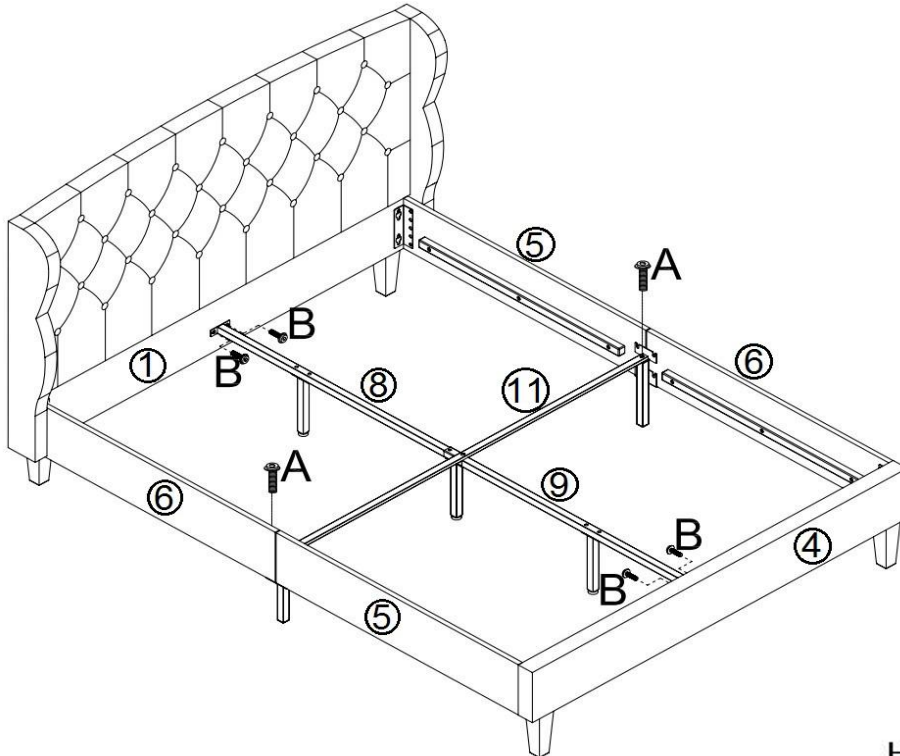

Hardware & Tools required

STEP 6:

Put 2 pieces of **Slats (13)** on the assembled bed in Step 5 as shown.

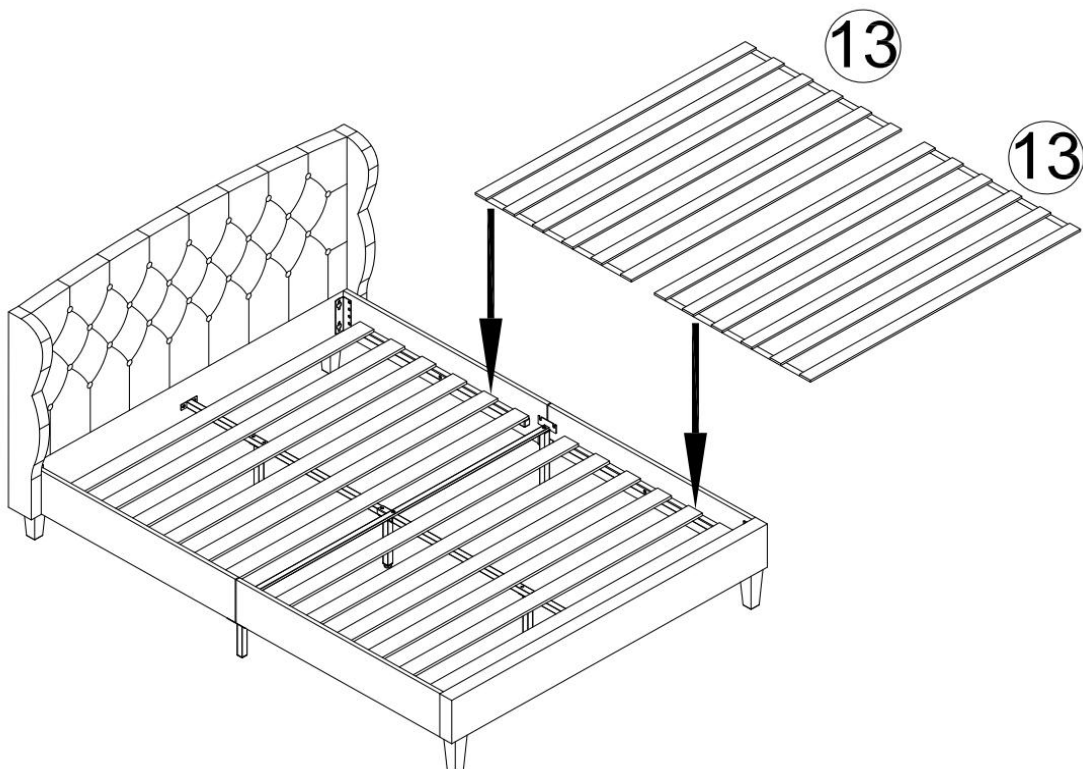

Assembly is complete, your queen bed is ready to be used now!