

Recommended Maximum Weight

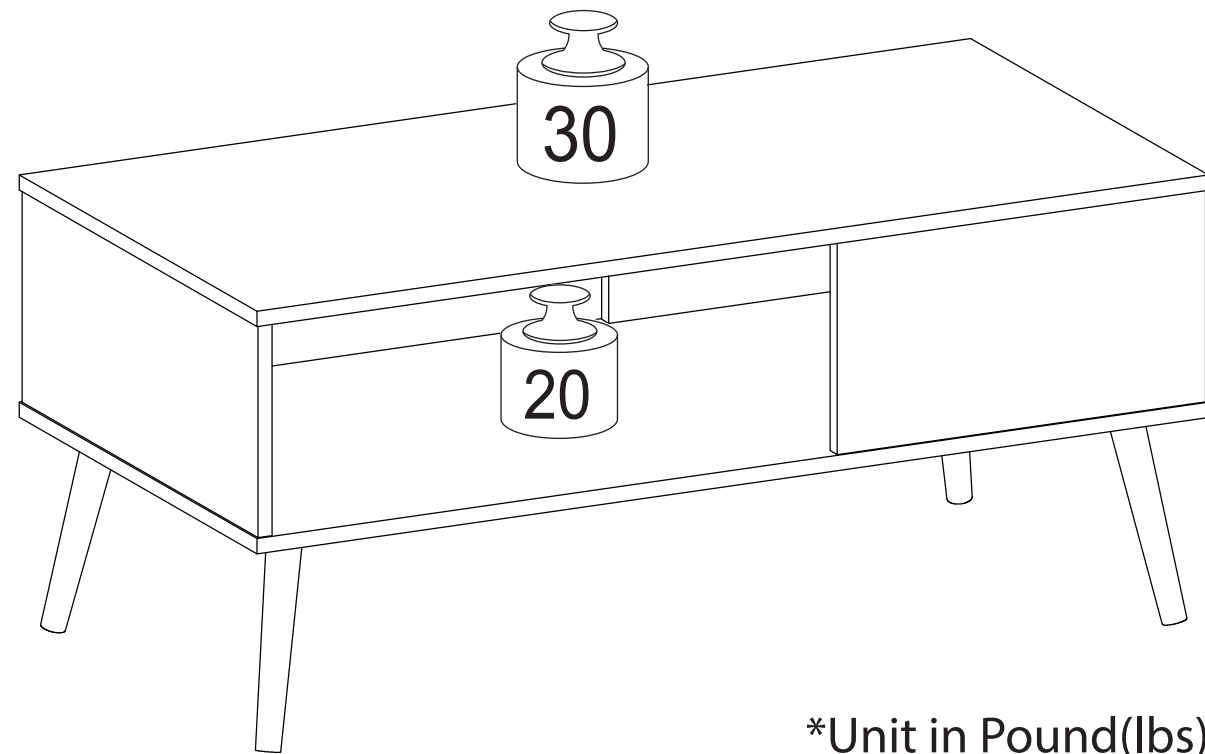

*Unit in Pound(lbs)



WARNING:

>This unit has been designed to support the maximum loads shown. Exceeding these load limits could cause sagging, instability, product collapse, and/or serious injury.

>DO NOT allow children to climb on unit.

>DO NOT sit on the product.

00:20

Approx. 20 minutes



Recomm. 1 Person

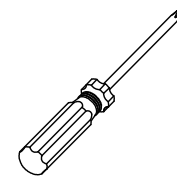





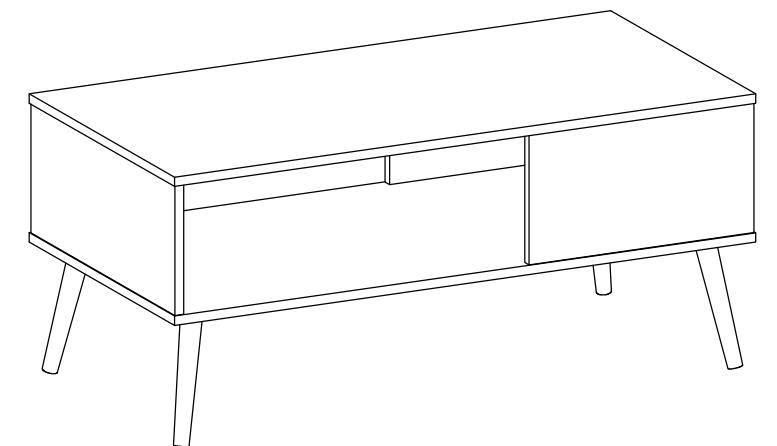

Tools Required

Assembly Instruction

Coffee Table with Wood Legs



HARDWARE & PARTS LIST

NO	HARDWARE LIST	QTY
1	MINIFIX  	6sets
2	LONG SCREW 	6pcs
3	DOWEL 	12pcs
4	WOODEN LEG 	4pcs
5	METAL SUPPORT PLATE 	4pcs
6	SHORT SCREW 	20pcs

NO	PARTS LIST	QTY
A	TOP PANEL	1pc
B	BOTTOM PANEL	1pc
C	CENTER PANEL	1pc
D	SIDE PANEL	2pcs

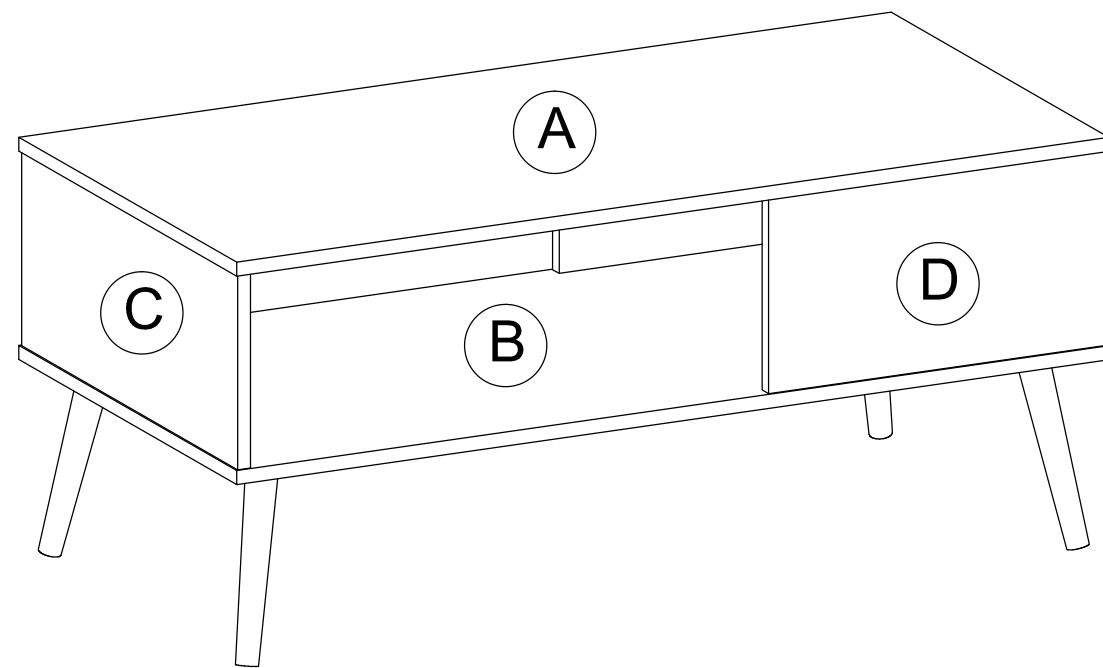

STEP 8

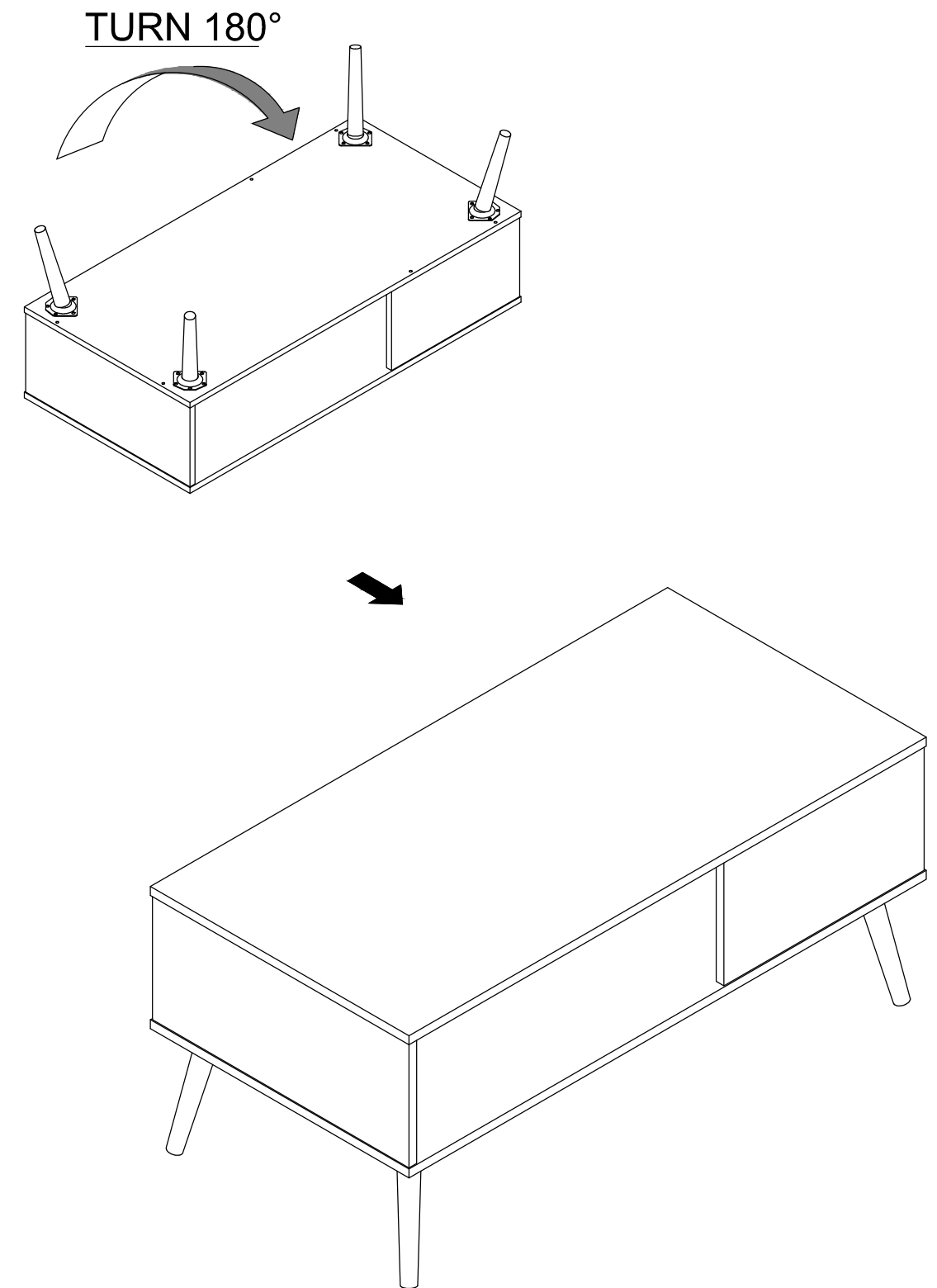

USEFUL HINTS BEFORE YOU START:

1. Read each step carefully before starting.
2. It is important that each step is performed in correct order to avoid difficulties.
3. Identify, sort and count the parts before assembly.
4. Assemble your furniture on packaging cardboard to prevent scratch or damage.
5. Clean the product with mild cleanser using soft damped cloth. Do not use harsh or abrasive cleanser.
6. Using incompatible hardware might cause damage to product.

STEP 6

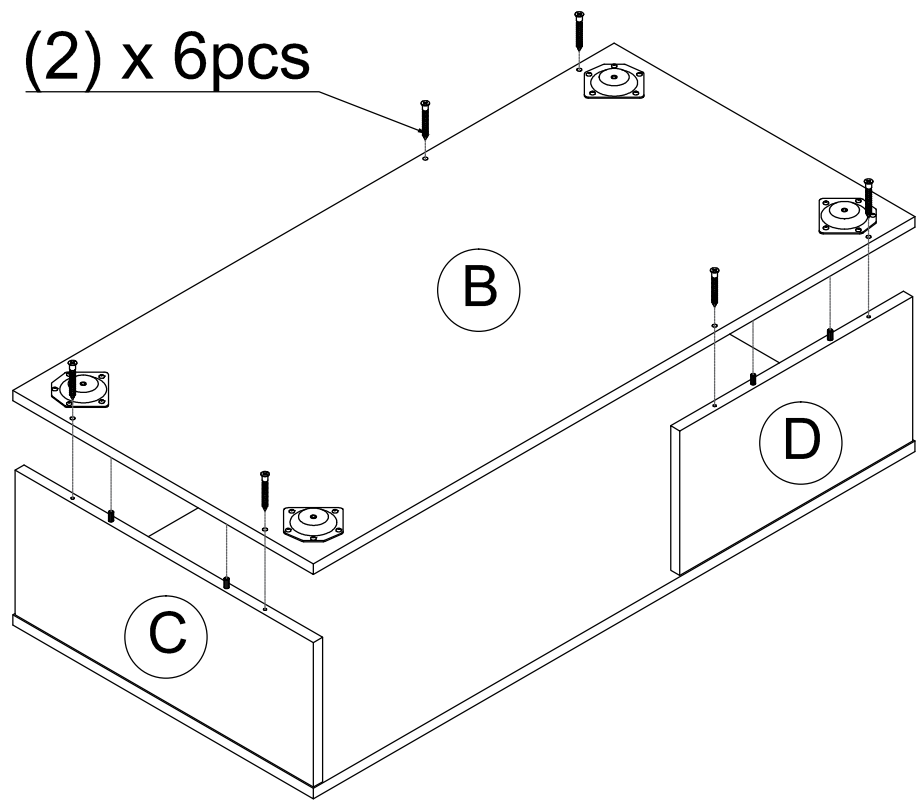

STEP 7

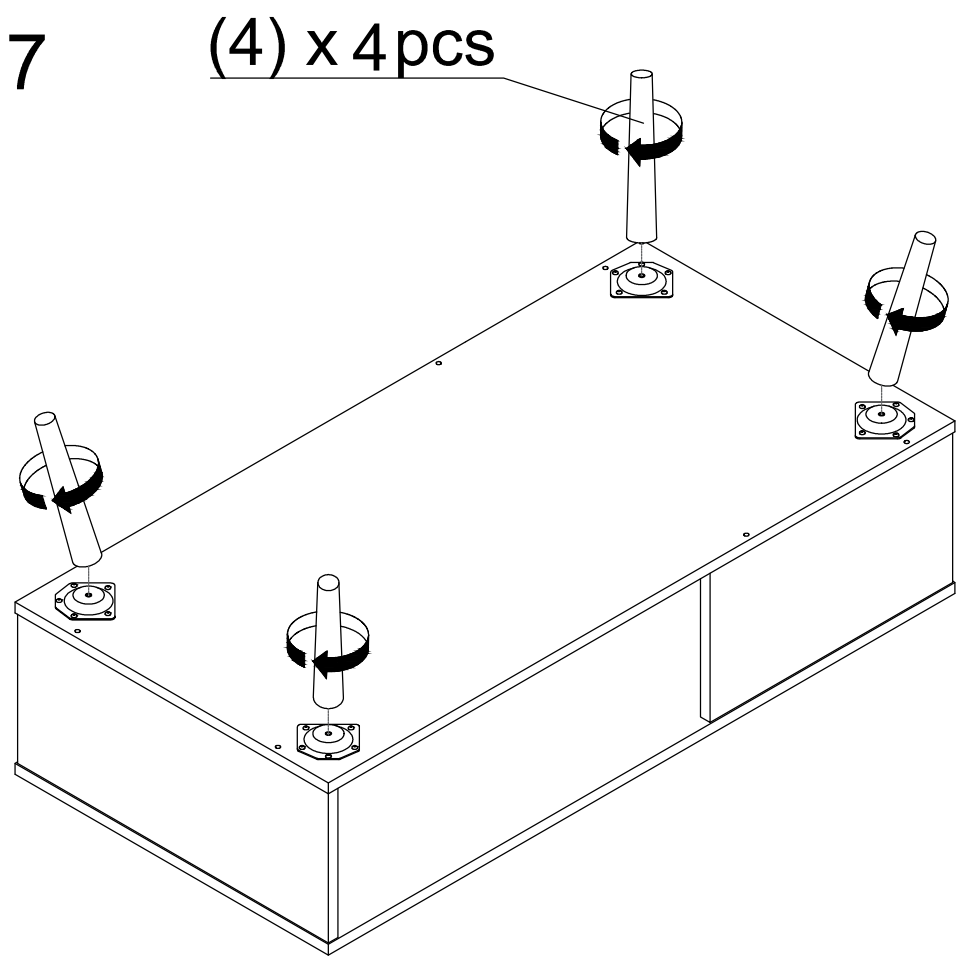

ASSEMBLY INSTRUCTIONS

BEFORE YOU BEGIN, PLEASE READ ASSEMBLY INSTRUCTIONS CAREFULLY, FOLLOW THEM STEP BY STEP.

STEP 1

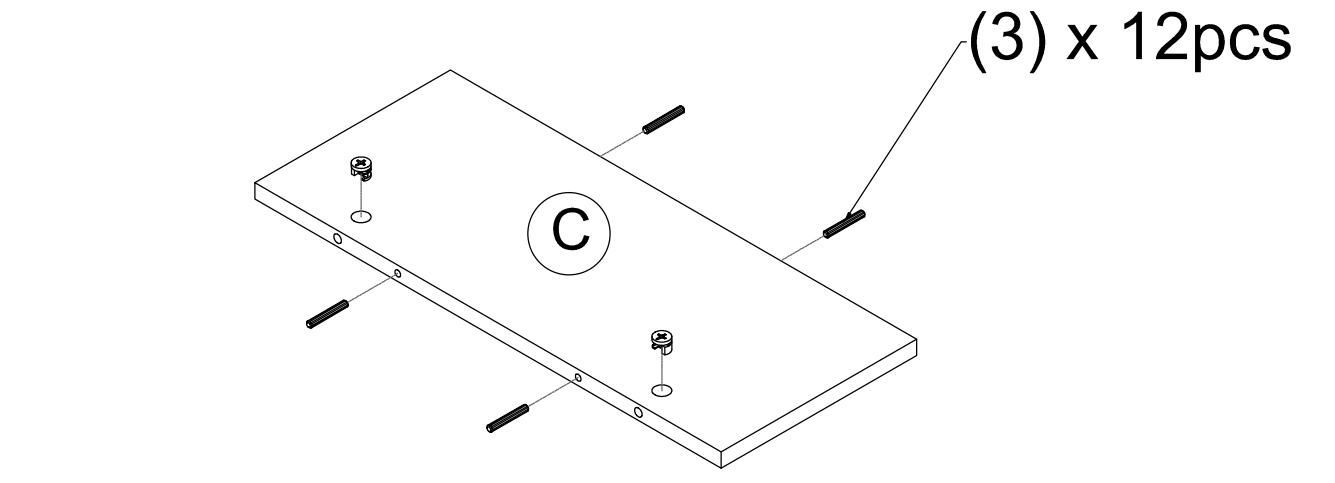

(1b) x 6pcs

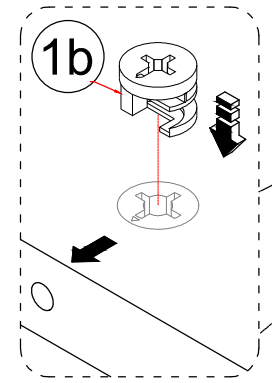
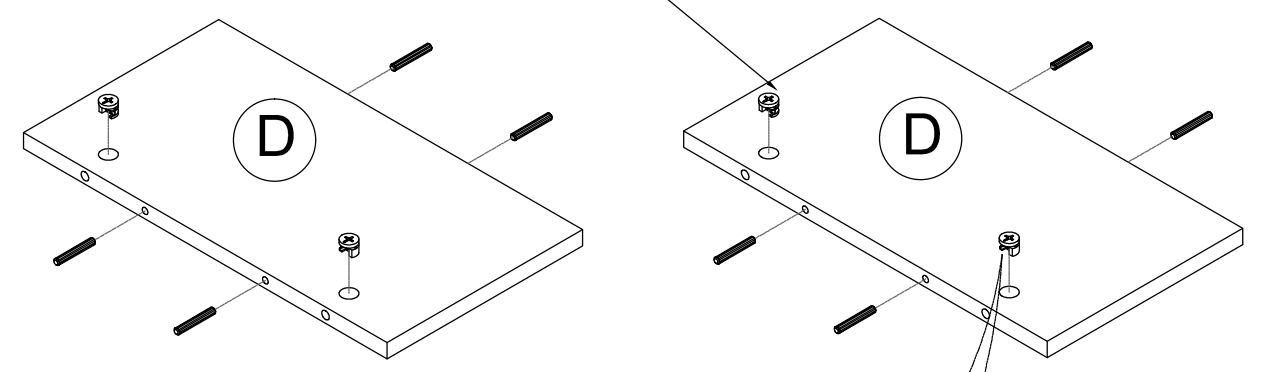

Arrow facing outward

STEP 2

(6) x 20 pcs

(5) x 4 pcs

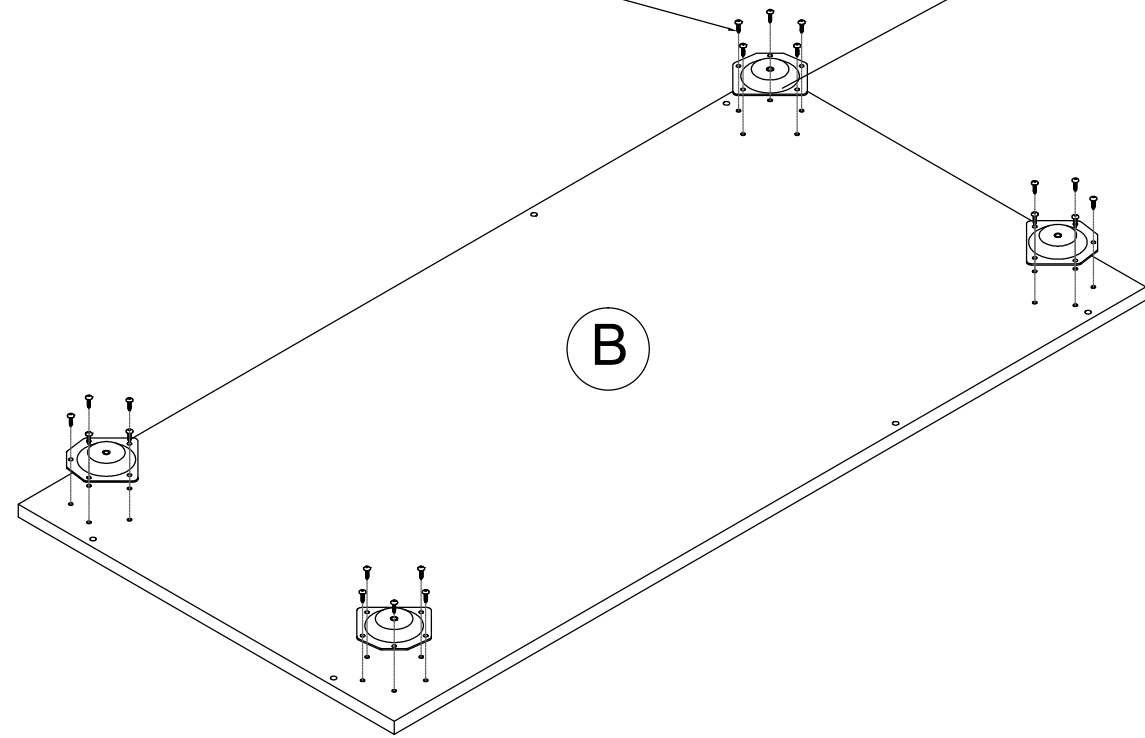

STEP 4

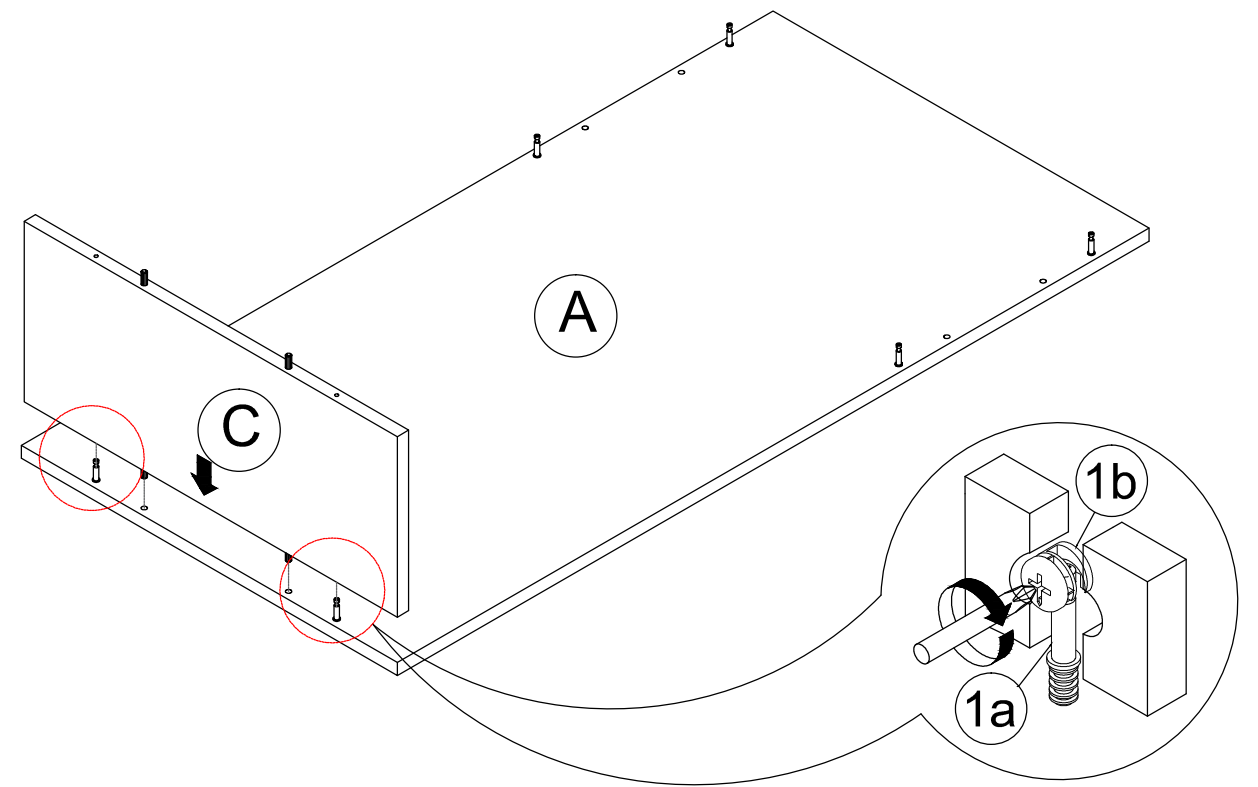

STEP 3

(1a) x 6 pcs

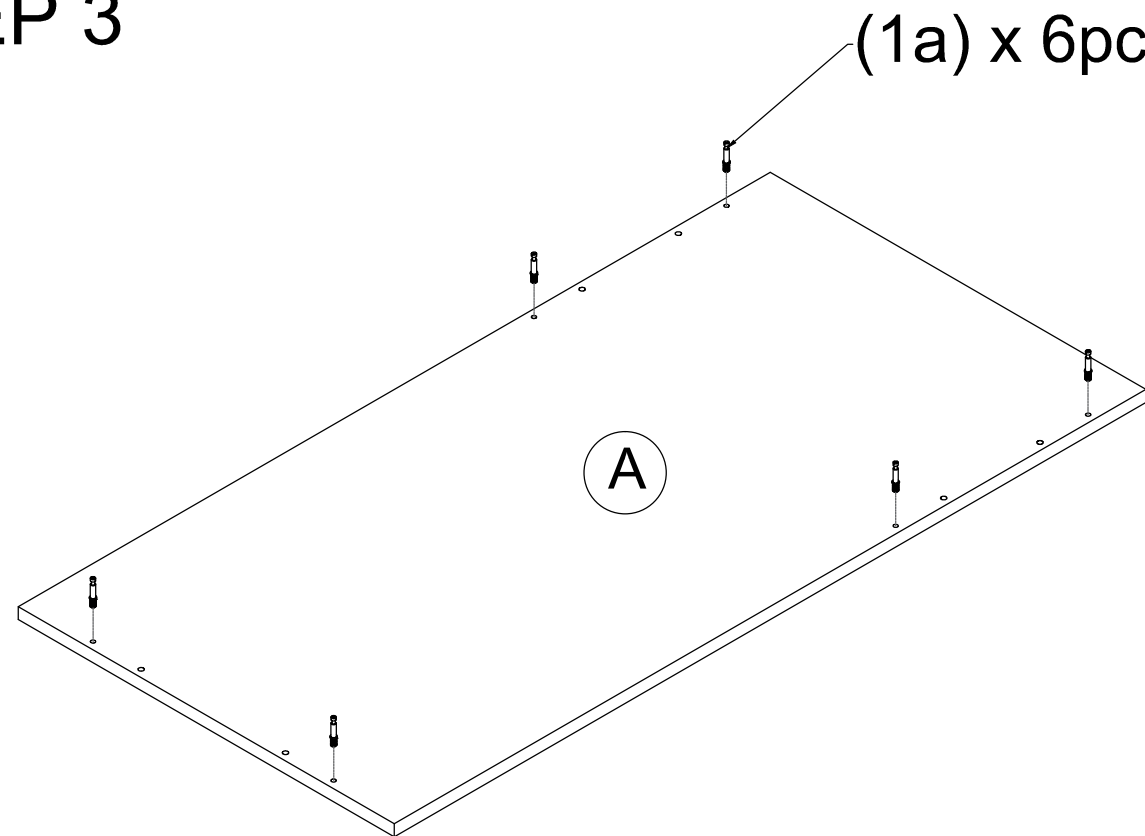

STEP 5

