

Assembly Instructions

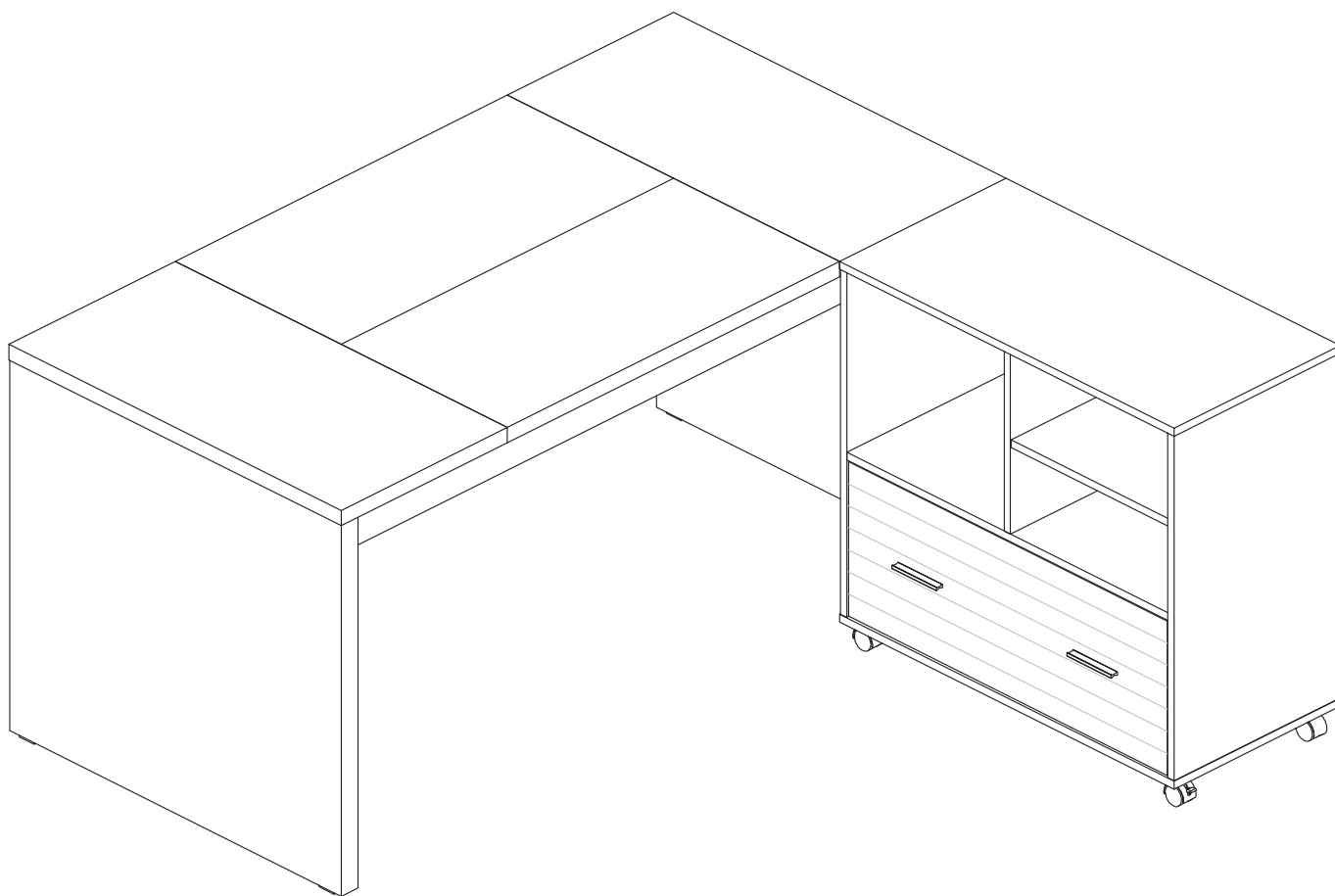

Executive Desk

Your satisfaction is our top priority. If you encounter any issues with this product, such as missing or damaged parts, we're here to help. Please retain the original packaging and take photos of the packaging and the product, then contact us as soon as possible.

Warm Tips

1. Carefully read these instructions and keep them for future reference.
2. Check the parts list and confirm everything's there before starting assembly.
3. When assembling, put all parts on a soft, smooth surface like a carpet to avoid scratches.
4. Don't fully tighten screws until all parts are confirmed in place to avoid misalignment.

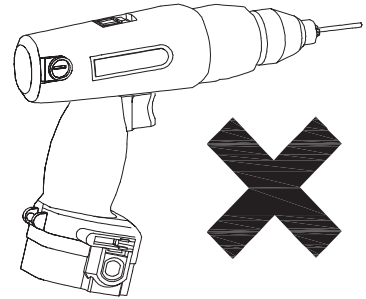
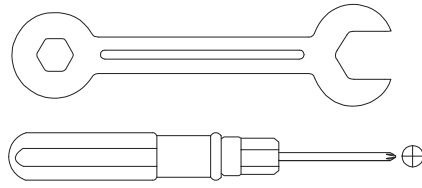
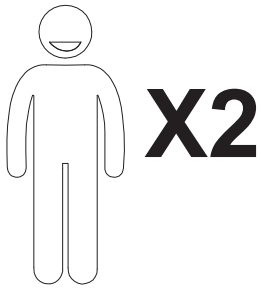

We recommend using hand tools for assembly.

If an electric screwdriver is used, reduce power and torque to avoid damage to the product.

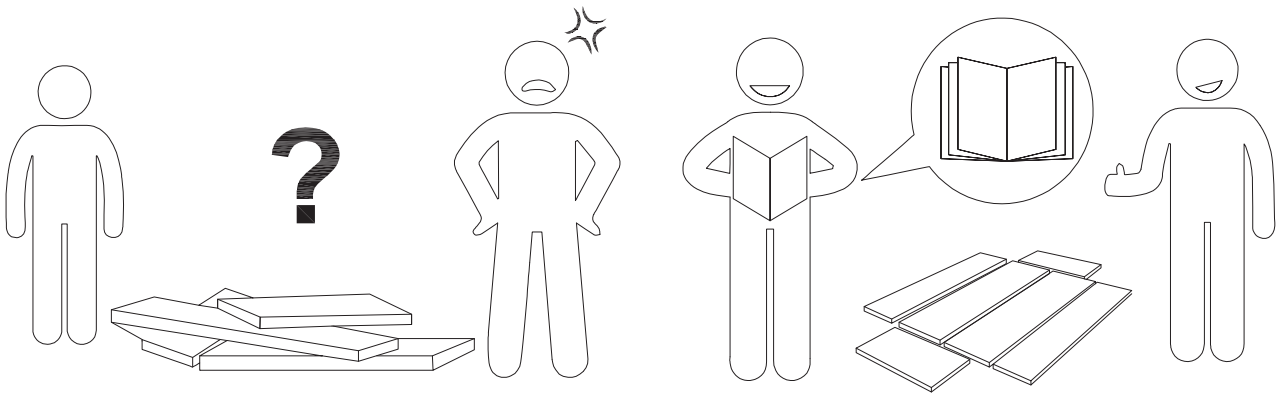

AVOID SCRATCHES

In order to avoid scratching, this furniture should be assembled on a soft surface, such as a rug.

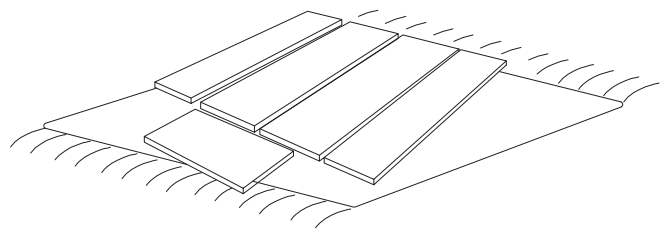
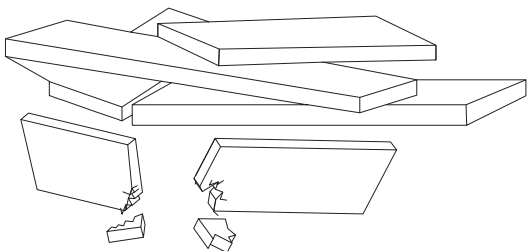

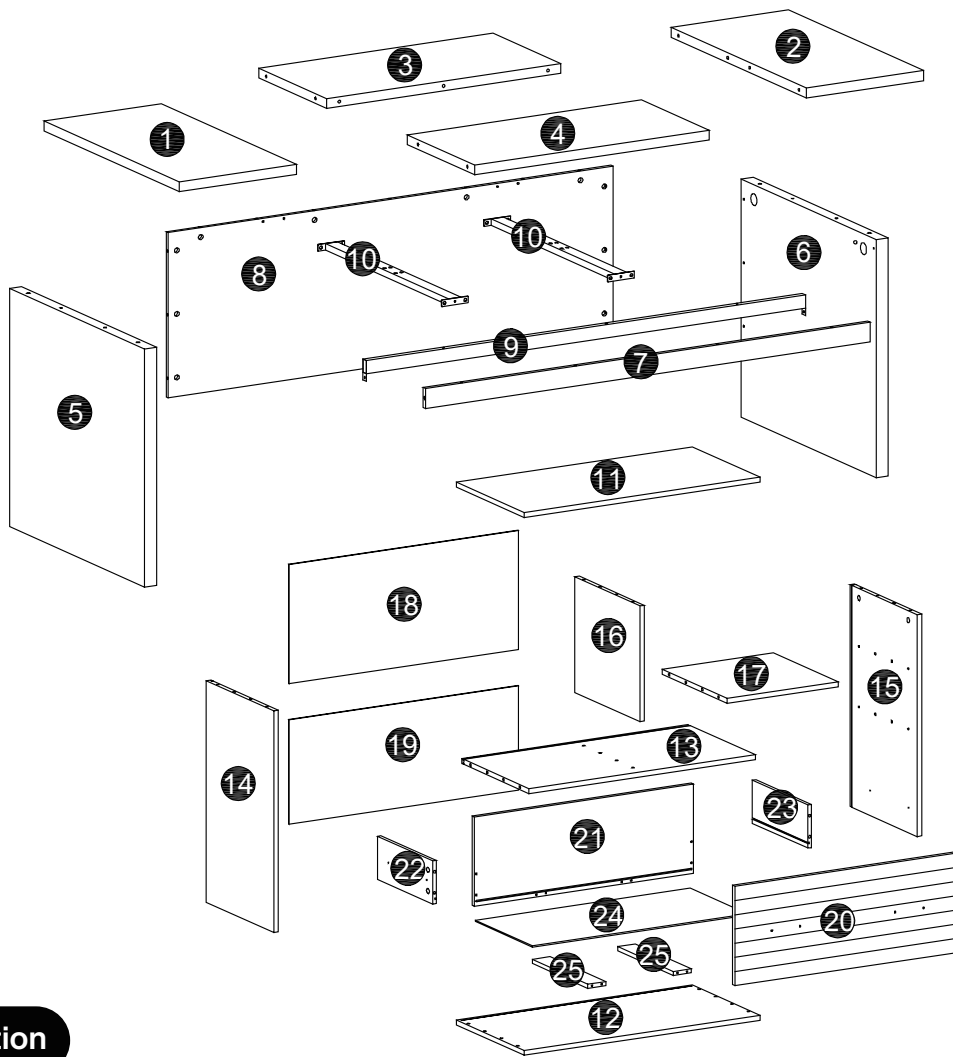

⚠ Caution











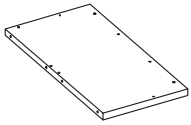
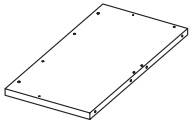
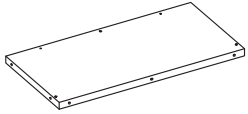
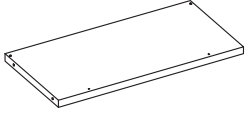
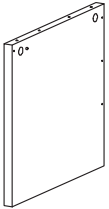
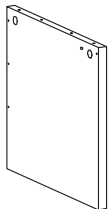

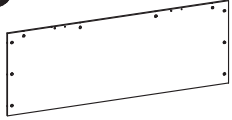
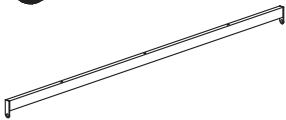
Make sure all parts are included. Most board parts are labeled or stamped on the raw edge. Contact us for a free replacement if you encounter any damaged or missing parts.

1	1 pc	2	1 pc
3	1 pc	4	1 pc
5	1 pc	6	1 pc
20	1 pc	21	1 pc

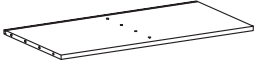



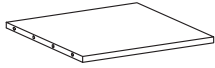
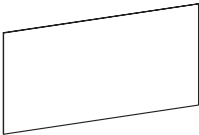
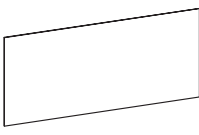
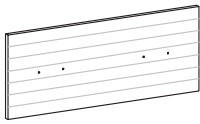
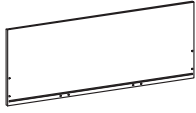
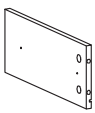
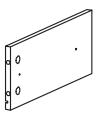

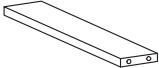



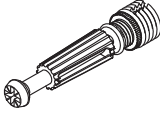

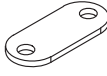
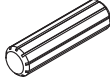

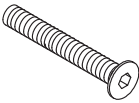
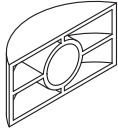
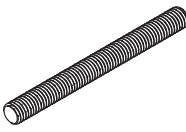
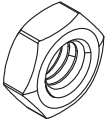
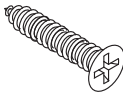

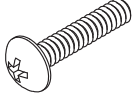
7	1 pc	8	1 pc
9	1 pc	10	2 pcs
11	1 pc	12	1 pc
13	1 pc	14	1 pc
15	1 pc	16	1 pc
17	1 pc	18	1 pc
19	1 pc	22	1 pc
23	1 pc	24	1 pc
25	2 pcs		

Before installation, please check if you have received the A, B packages, and check if the parts are complete.

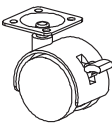
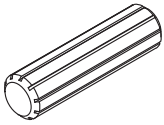
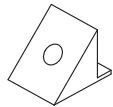
Parts List

<p>1</p>  <p>1PC</p>	<p>2</p>  <p>1PC</p>	<p>3</p>  <p>1PC</p>	<p>4</p>  <p>1PC</p>
<p>5</p>  <p>1PC</p>	<p>6</p>  <p>1PC</p>	<p>7</p>  <p>1PC</p>	<p>8</p>  <p>1PC</p>
<p>9</p>  <p>1PC</p>	<p>10</p>  <p>2PCS</p>	<p>11</p>  <p>1PC</p>	<p>12</p>  <p>1PC</p>
<p>13</p>  <p>1PC</p>	<p>14</p>  <p>1PC</p>	<p>15</p>  <p>1PC</p>	<p>16</p>  <p>1PC</p>
<p>17</p>  <p>1PC</p>	<p>18</p>  <p>1PC</p>	<p>19</p>  <p>1PC</p>	<p>20</p>  <p>1PC</p>
<p>21</p>  <p>1PC</p>	<p>22</p>  <p>1PC</p>	<p>23</p>  <p>1PC</p>	<p>24</p>  <p>1PC</p>
<p>25</p>  <p>2PCS</p>			

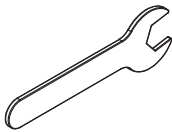
Hardware List

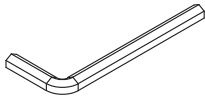
A	B	C	D	E	F
					
M6x40mm	Ø15x12mm	M56x24mm	Ø8x30mm	Ø6x10mm	Ø6x35mm
42 pcs	42 pcs	1 pc	26 pcs	12 pcs	8 pcs
G	H	I	J	K	L
					
Ø6x55mm	M8	M8x70mm	M8	Ø3.5x35mm	Ø3.5x14mm
3 pc	4 pcs	4 pcs	4 pcs	8 pcs	48 pcs
M	N	O	P	Q	R
					
Ø4x20mm	Ø7x38mm	L300mm	L300mm	8x15x105mm	H55mm
4 pcs	2 pcs	2 pcs	2 pcs	2 pcs	4 pcs
S	T	U	V	W	X
					
Ø10x40mm	12x14x10mm	318x25x22mm	735x35x16mm	M6	M14
15 pcs	12 pcs	4 pcs	2 pcs	4 pcs	1 pc
Y	Z				
					
	M3				
1 pc	1 pc				

Installation of Cams and Pins

Read each step carefully before starting. Each step of instruction should be performed in the correct order. If these steps are not followed in sequence, assembly difficulties may occur.

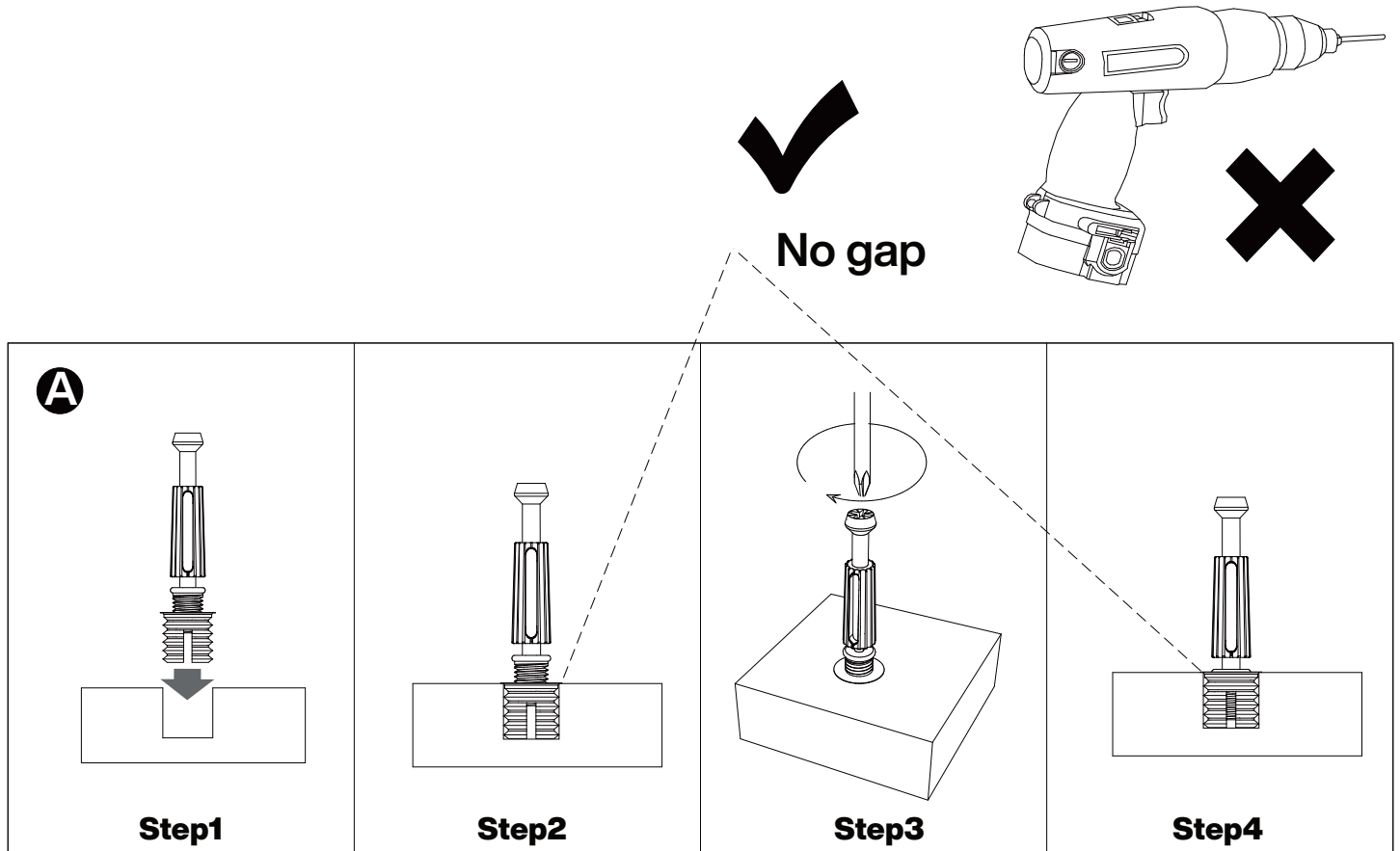

Screw the pin into the hole. Set the cams correctly by aligning the head of the cams with the lock pins. Lock the cam by turning the cam head with a screwdriver until it is tightened. Please do not use an electric screwdriver to assemble the unit.

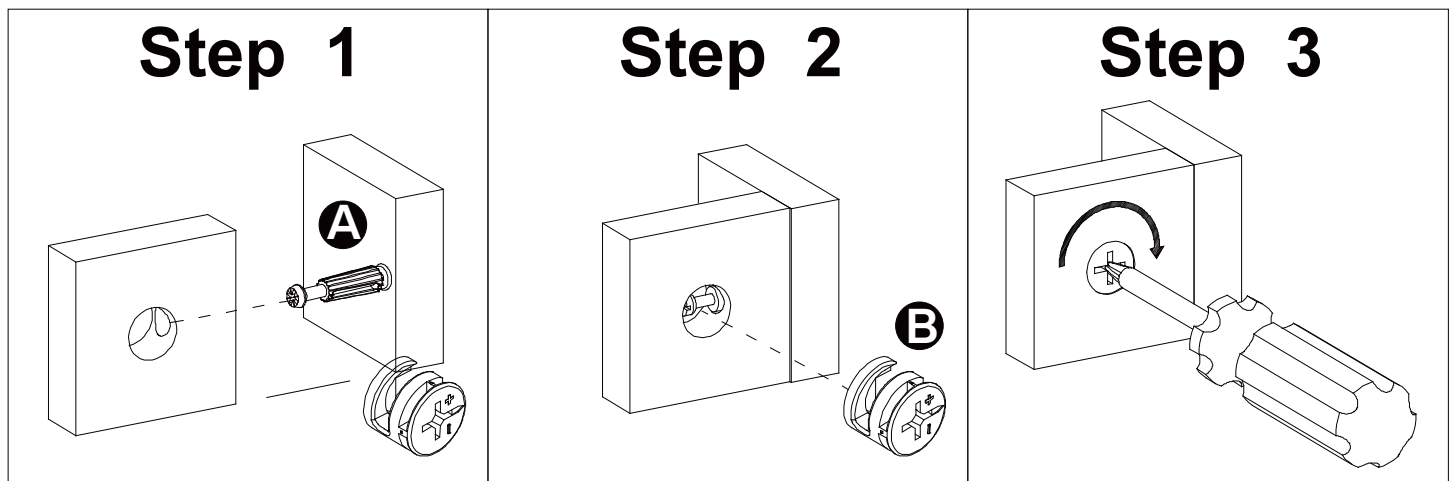

Please split component "O/P" into "O" and "P" before assembling the slide and then proceed to the next step of assembly

Step 1

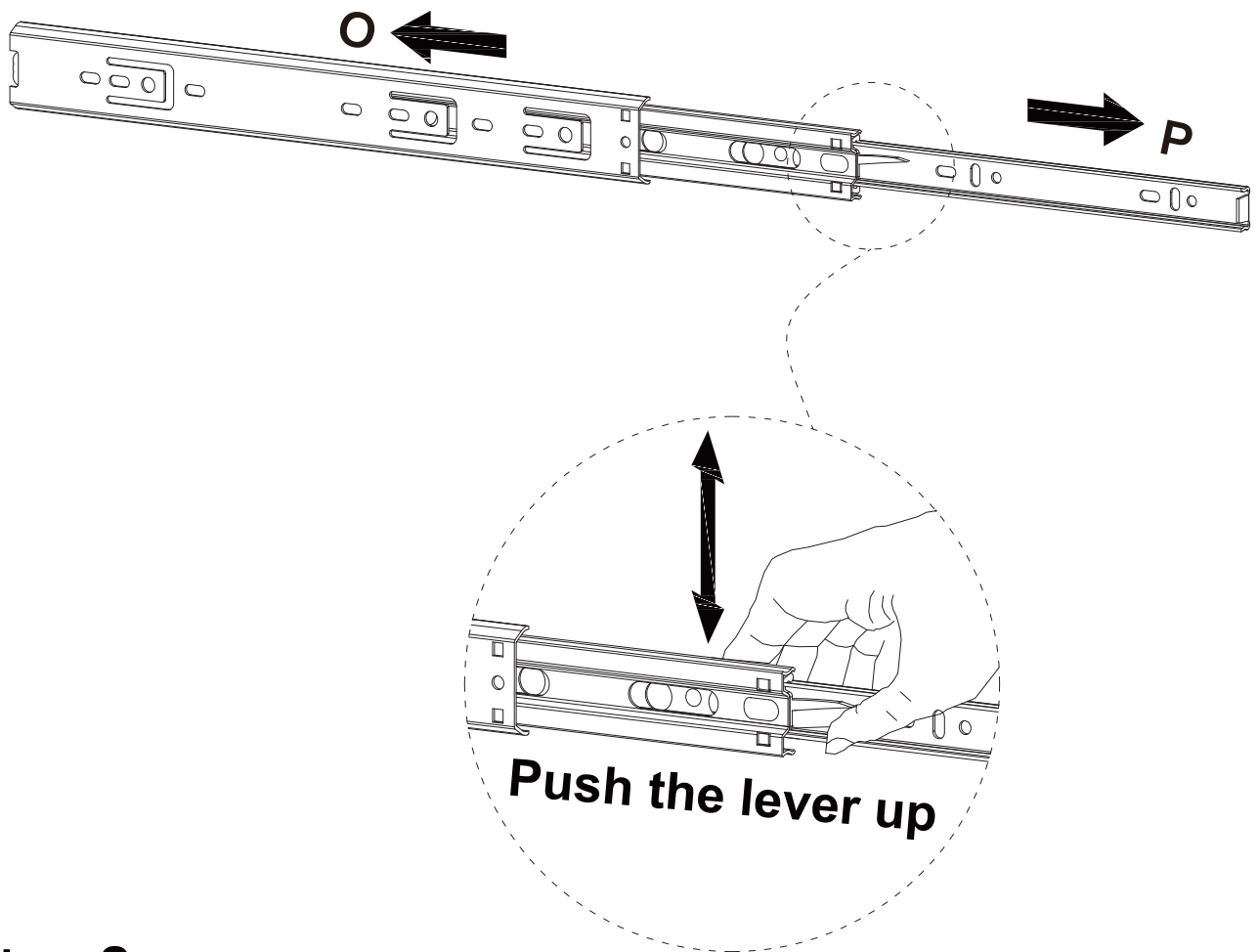

Pull apart component "O/P" to each side, and then gently push up the lever of component "P"

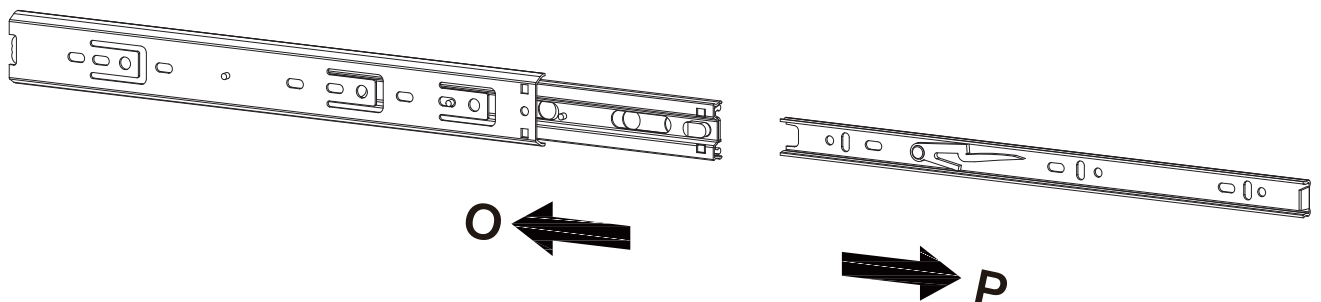

Step 2 Split component "O" and "P"



1

Y	A	I
	 M6x40mm	 M8x70mm
1 pc	16 pcs	4 pcs

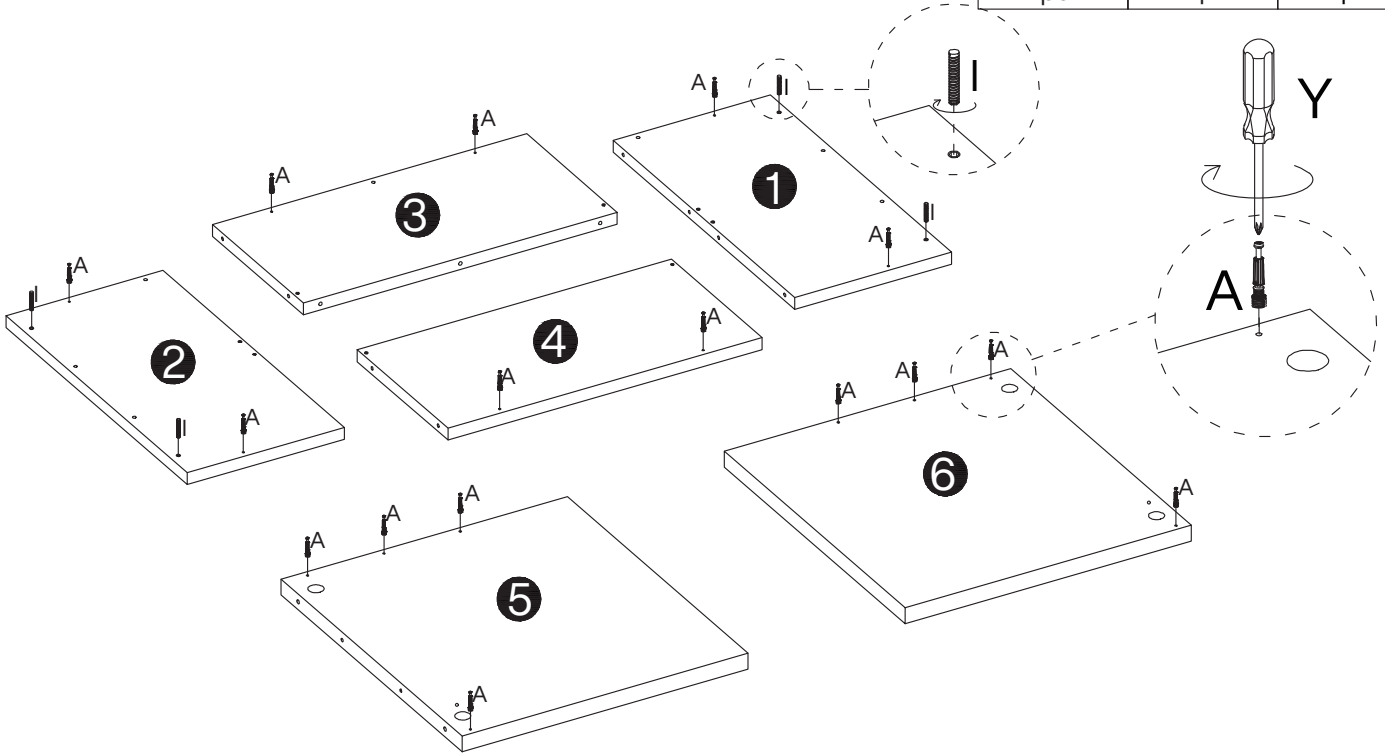

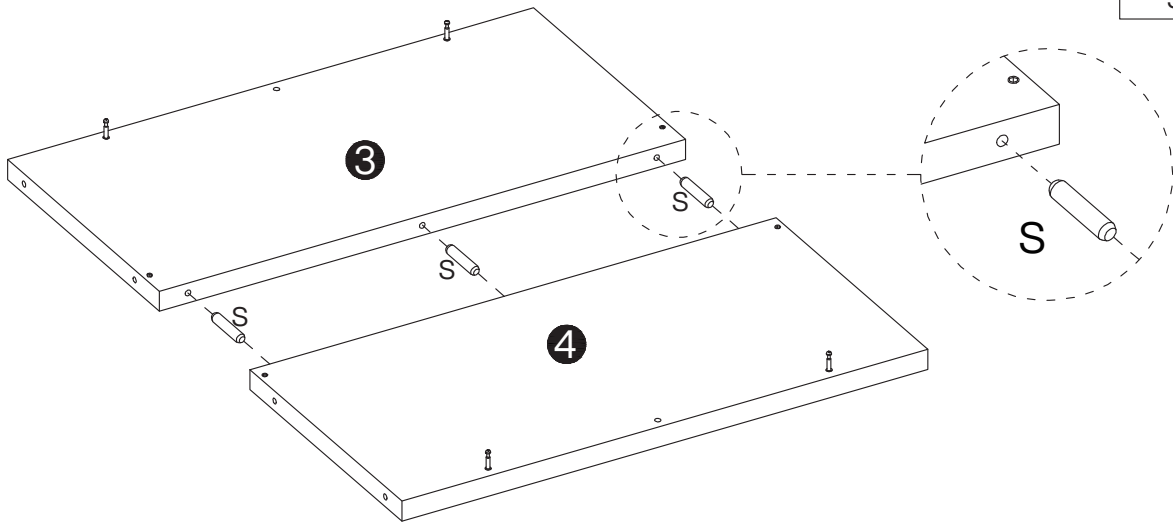

2

S

Ø10x40mm
3 pcs





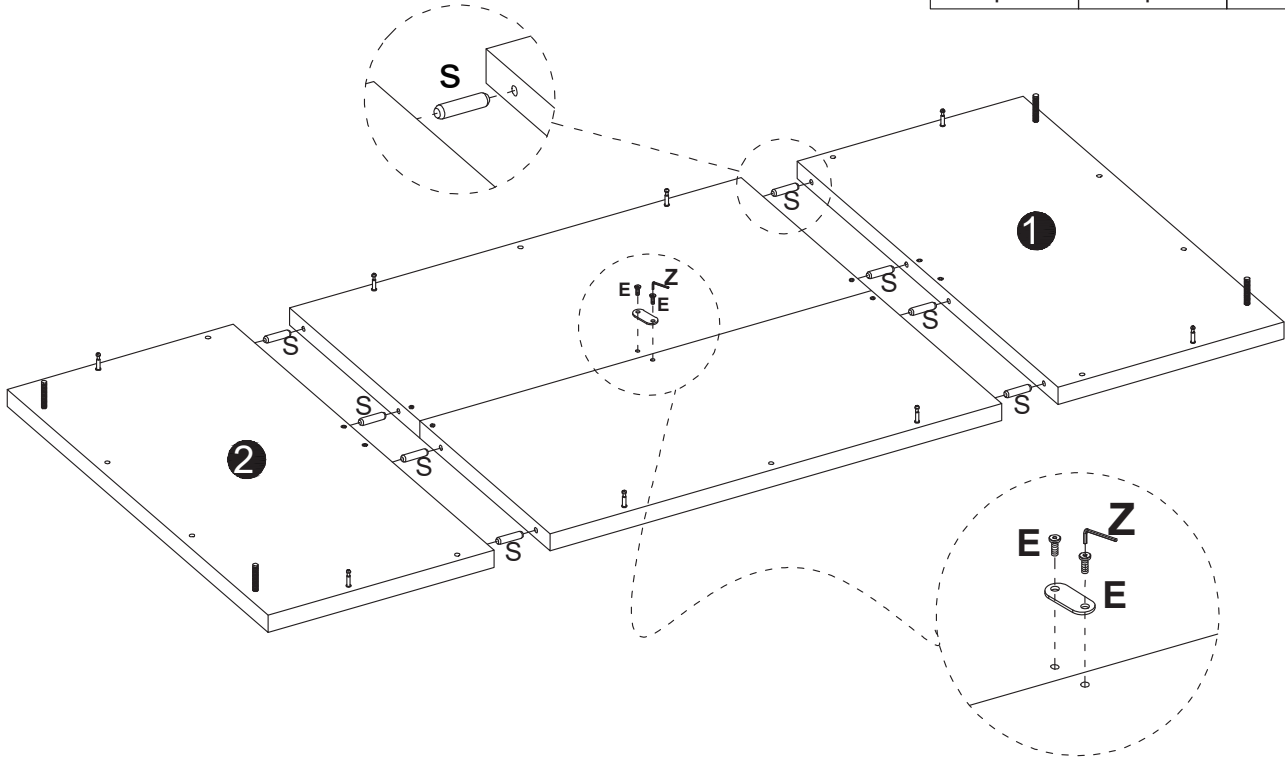

3

E	C	S
		
Ø6x10mm	M56x24mm	Ø10x40mm
2 pcs	1 pc	8 pcs





4

F	S
	
Ø6x35mm	Ø10x40mm
8 pcs	4 pcs

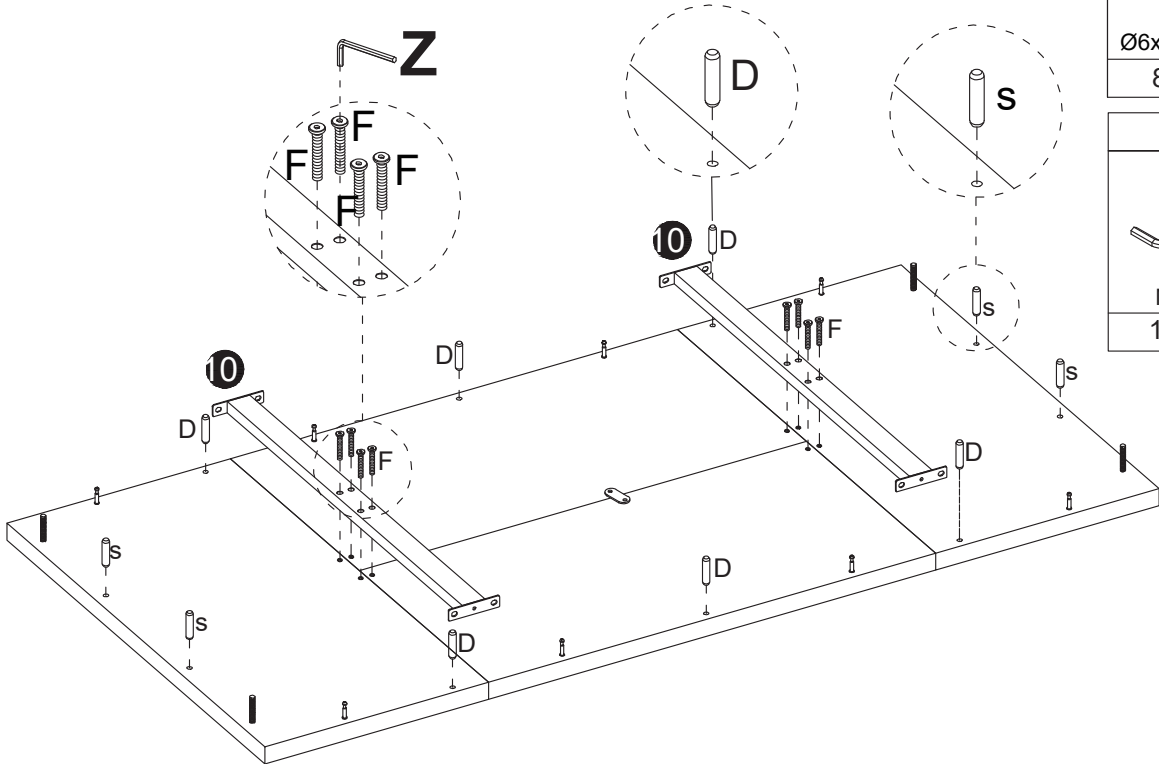
Z	D
	
M4	Ø8x30mm
1 pc	6 pcs



5

Y	B
	
1 pc	8 pcs Ø15x12mm

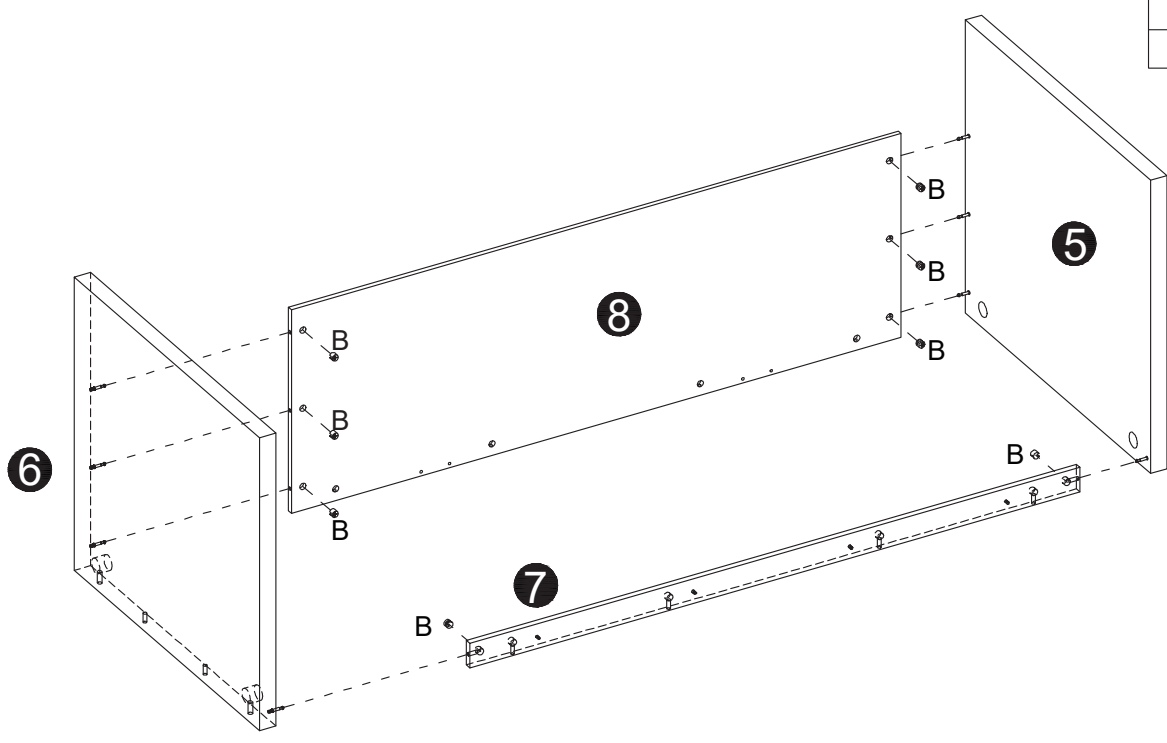

Step 1

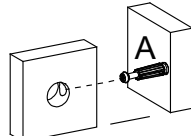

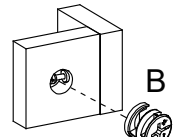

Step 2

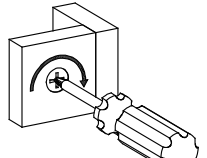

Step 3





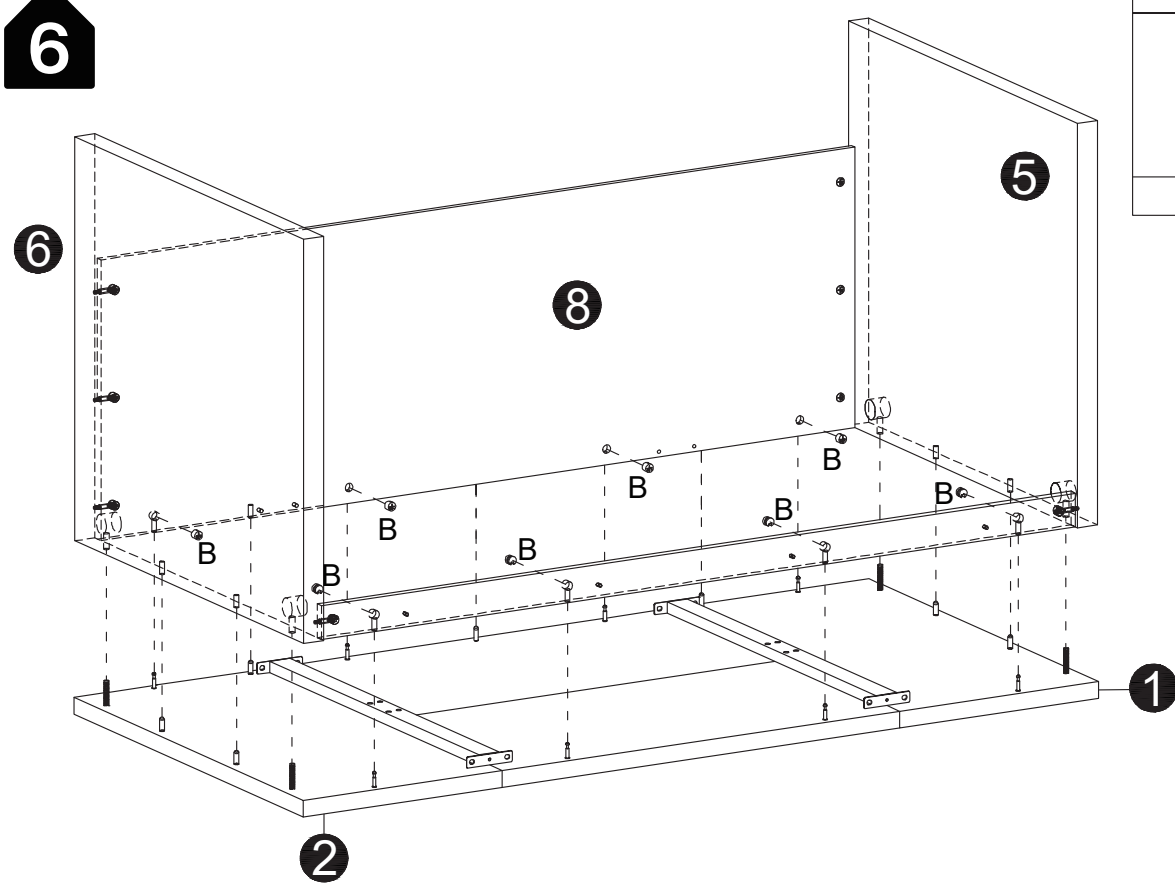

6

Y	B
	
1 pc	8 pcs Ø15x12mm

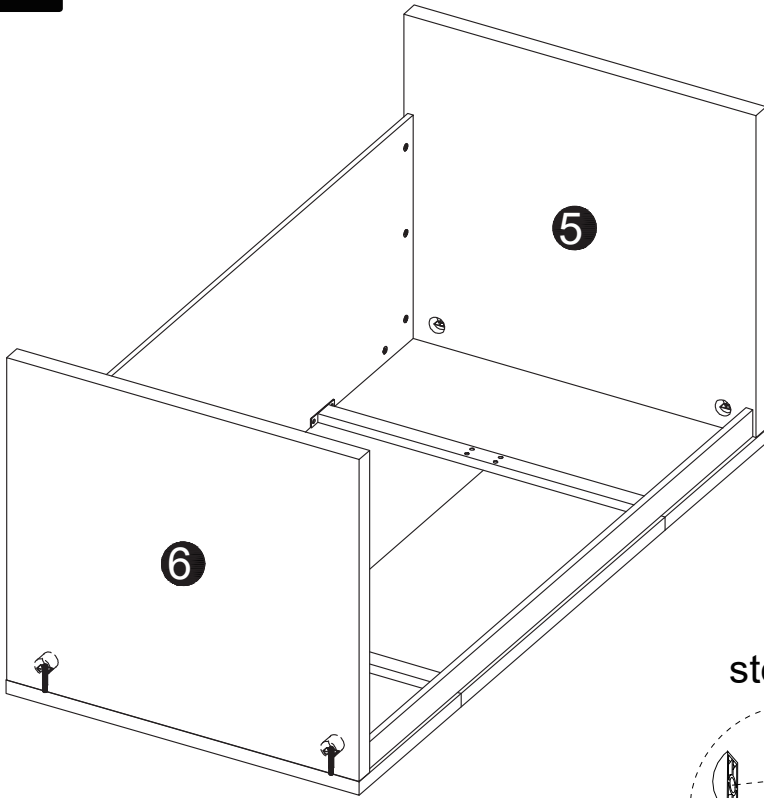

7



X	H	J
		
M14	M8	M8
1 pc	4 pcs	4 pcs

step 1

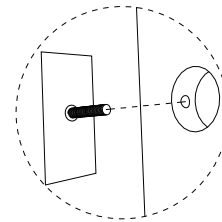

step 2

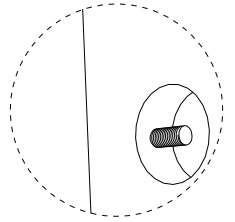

step 3

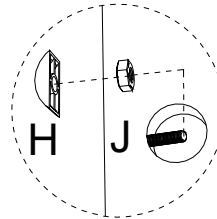

step 4

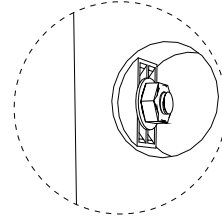

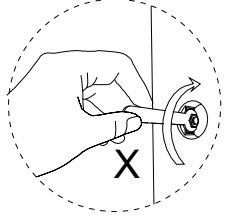

step 5



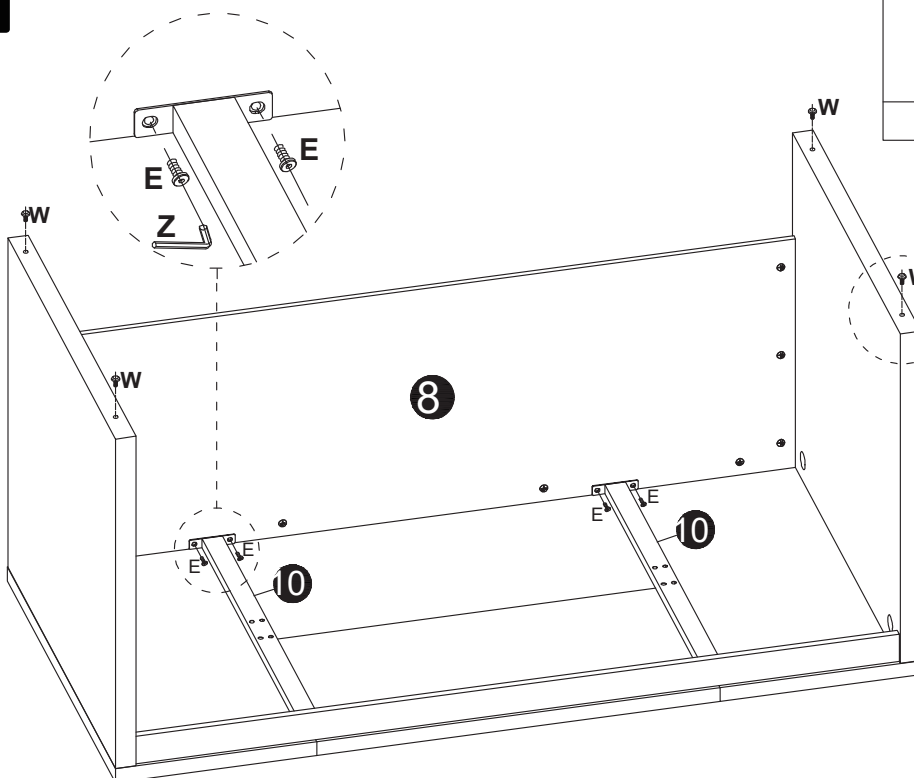

8

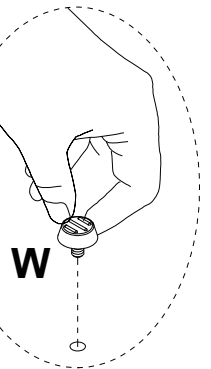

W	Z	E
		
M6	M4	Ø6x10mm
4 pc	1 pc	4 pcs

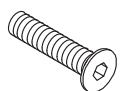

9

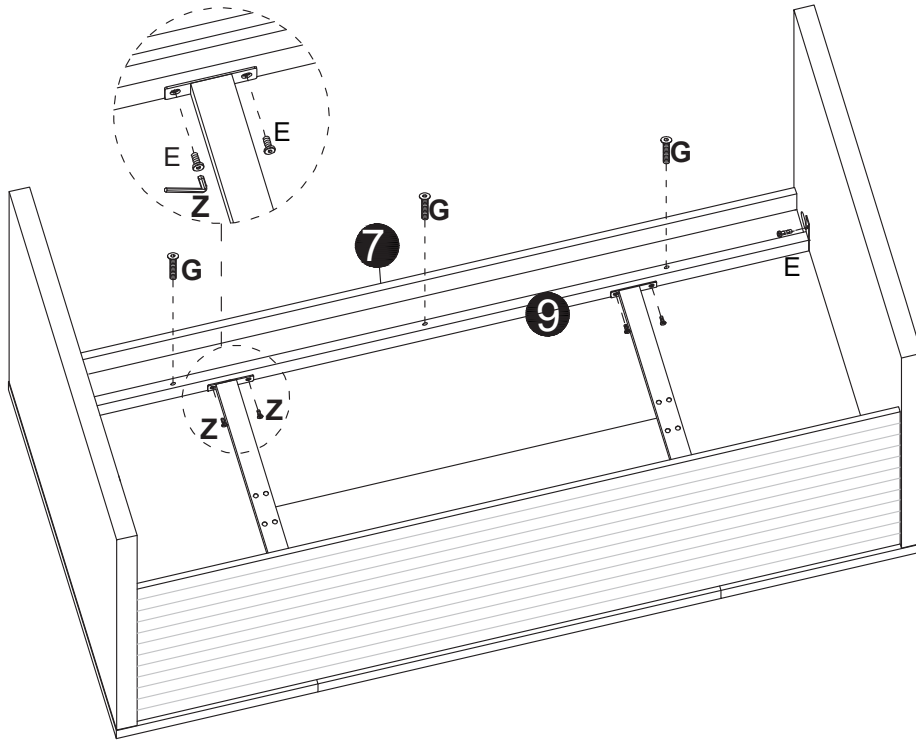

G	Z	E
		
Ø6x55mm	M4	Ø6x10mm
3 pcs	1 pc	6 pcs

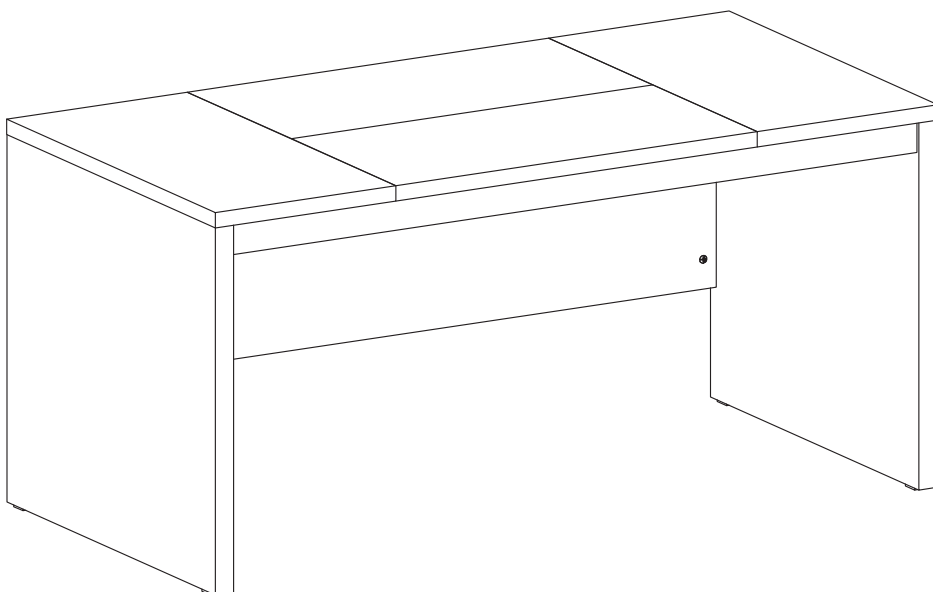

10



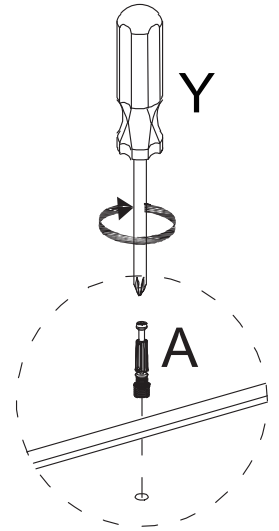
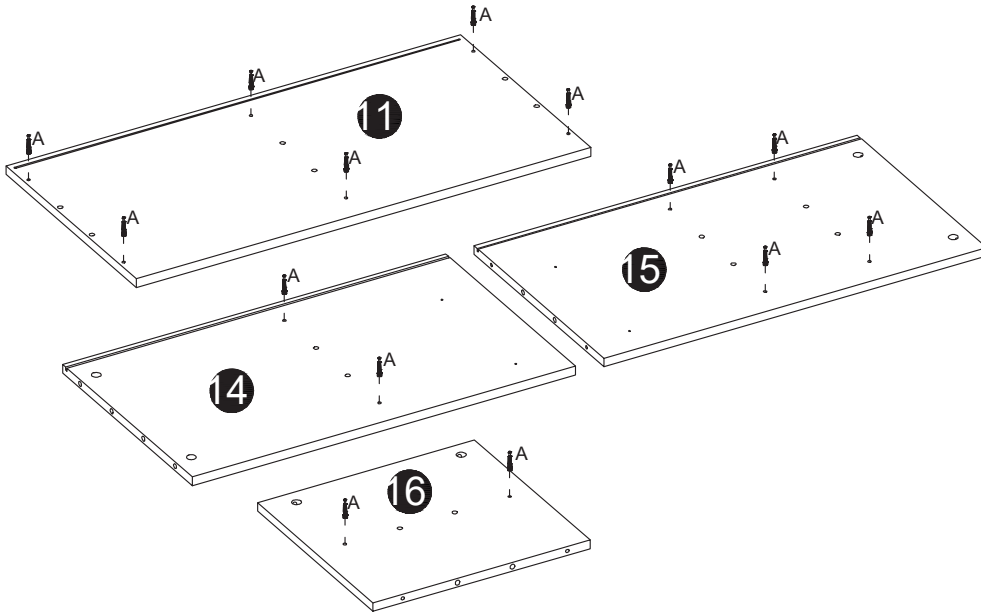

11

Y	A
	
1 pc	M6x40mm 14 pcs



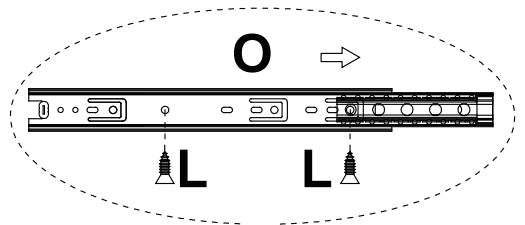
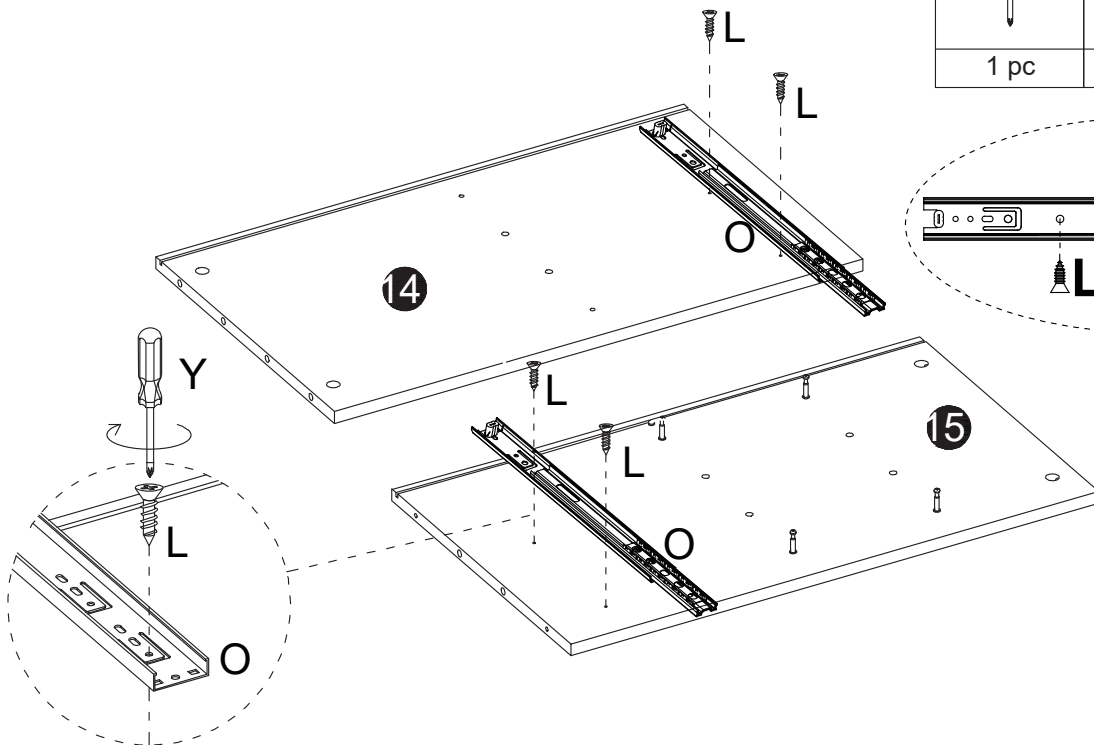

12

Y	O	L
		
1 pc	L300mm 2 pcs	Ø3.5x14mm 4 pcs



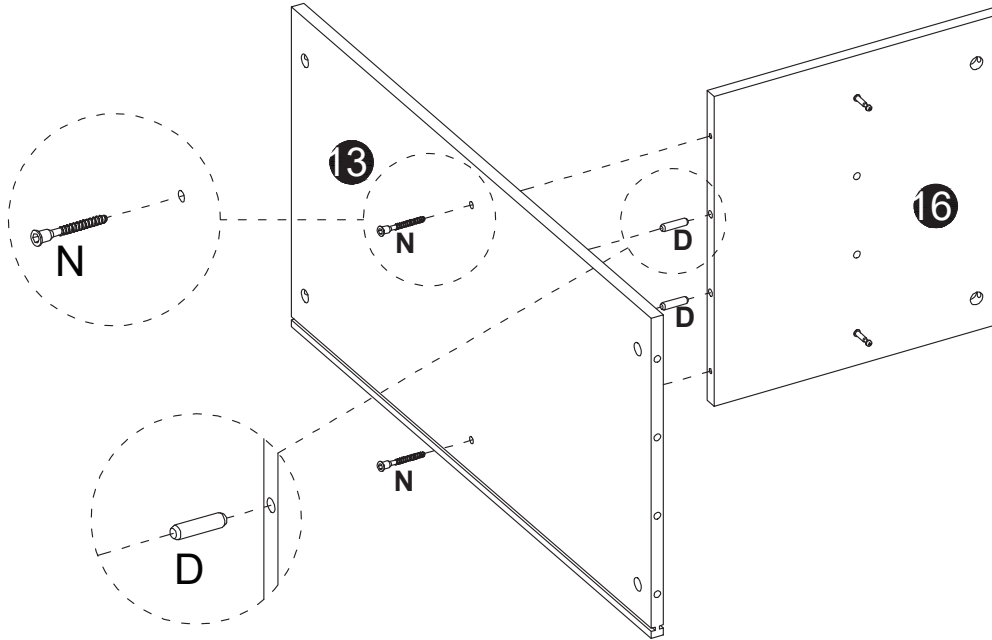

13

N	D
	
Ø7x38mm	Ø8x30mm
2 pcs	2 pcs



14

B	D
	
Ø15x12mm	Ø8x30mm
8 pcs	8 pcs

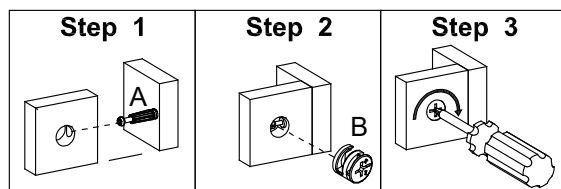
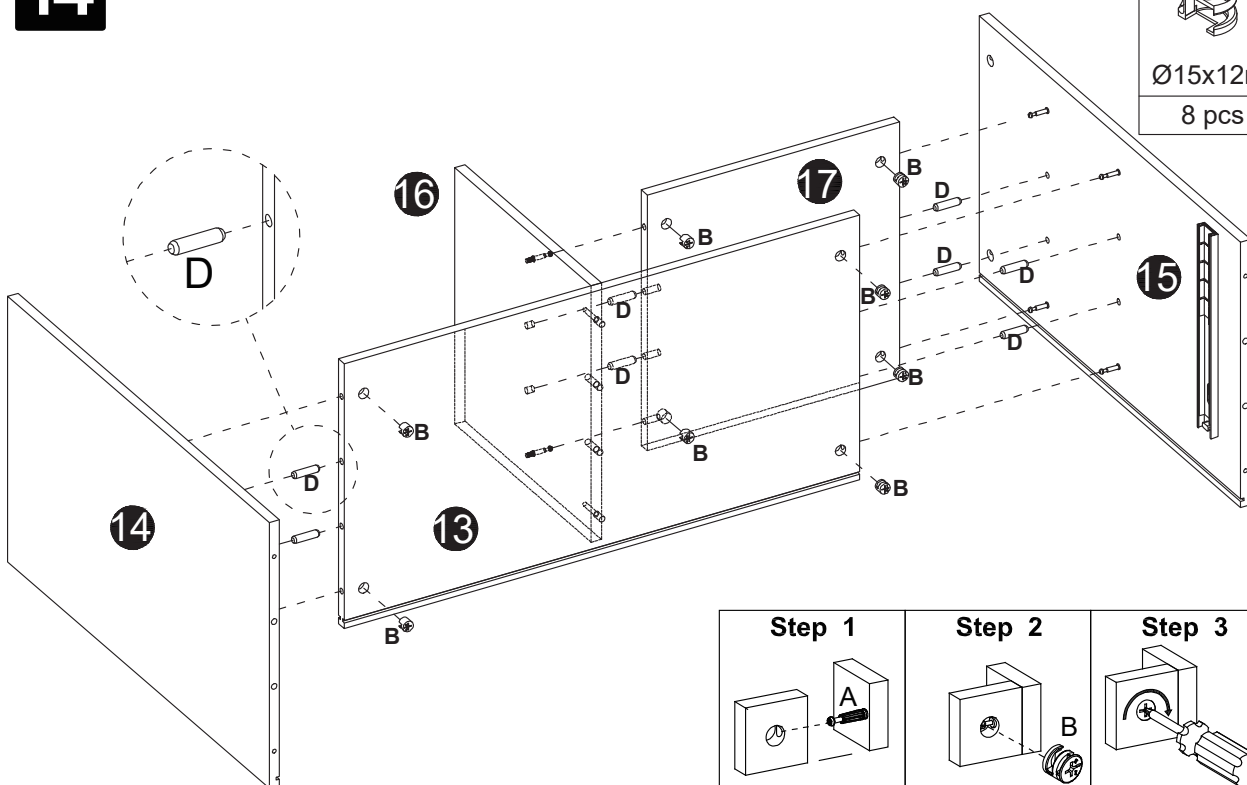

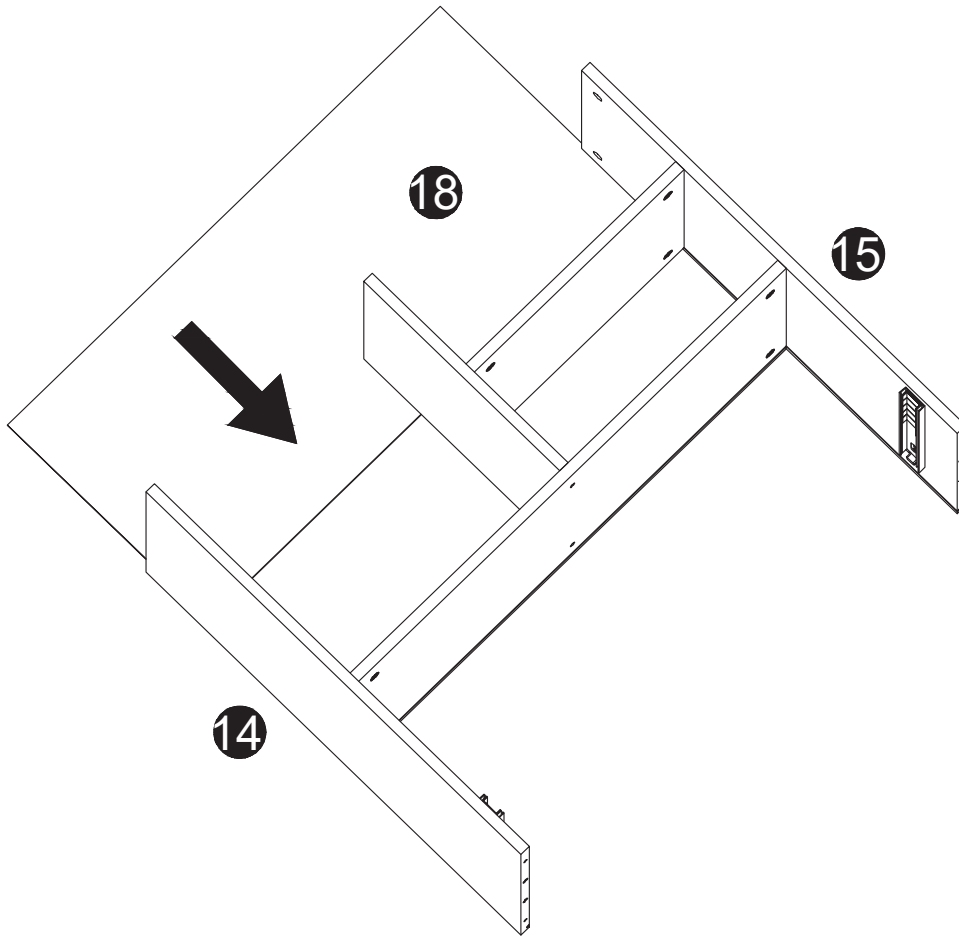

15

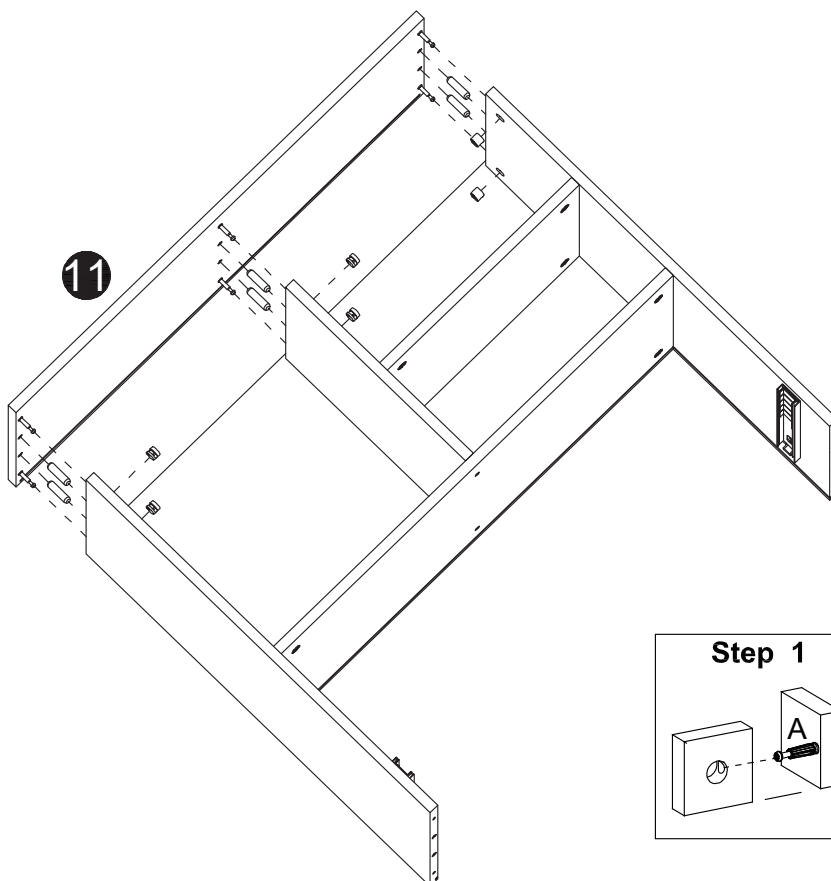

16



Y	B	D
		
1 pc	6 pcs Ø15x12mm	6 pcs Ø8x30mm

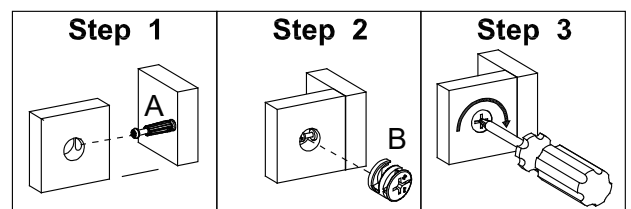

17

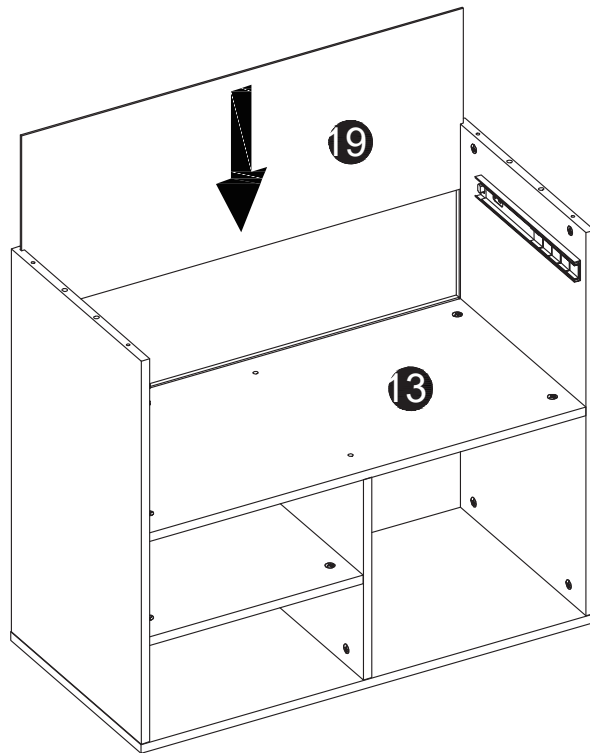

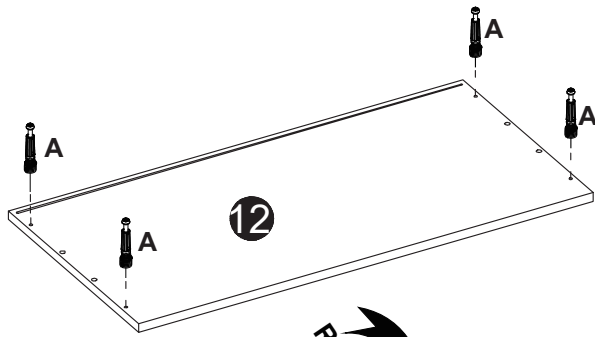

18



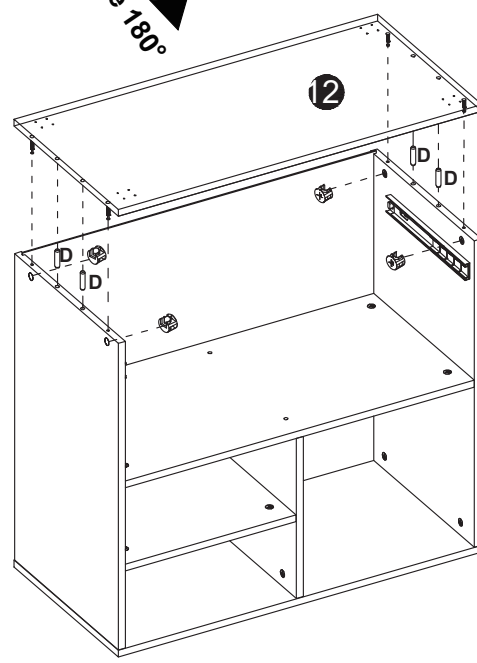
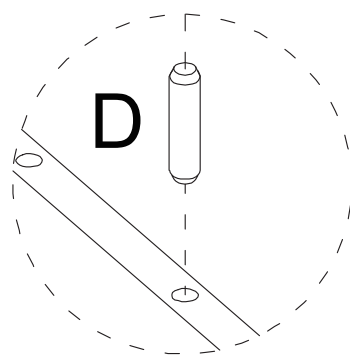

Rotate 180°

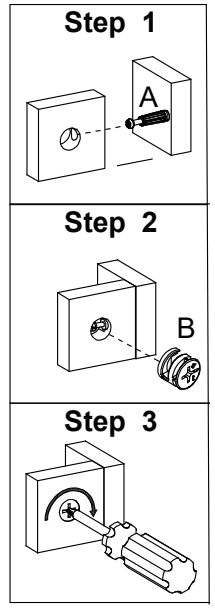

A	D	B
		
M6x40mm	Ø8x30mm	Ø15x11mm
4 pcs	4 pcs	4 pcs



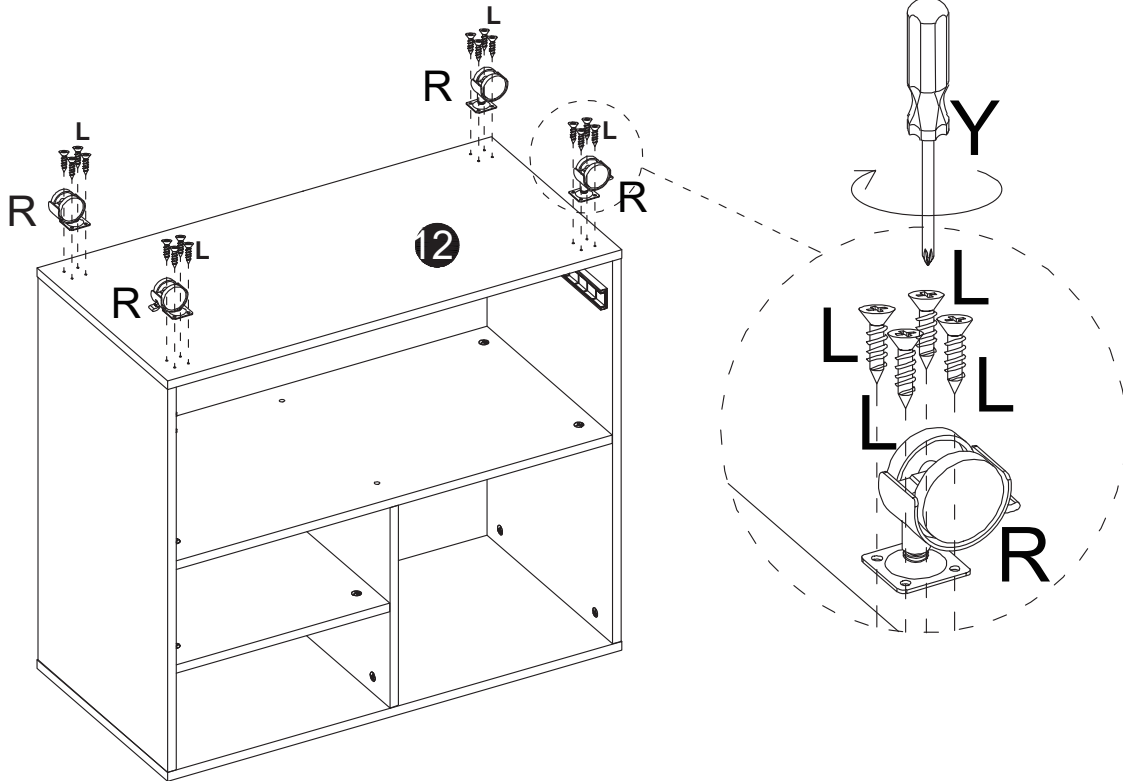

19

L	R
	
Ø3.5x14mm	H55mm
16pcs	4pcs



20

L	T
	
Ø3.5x14mm	
12pcs	12pcs

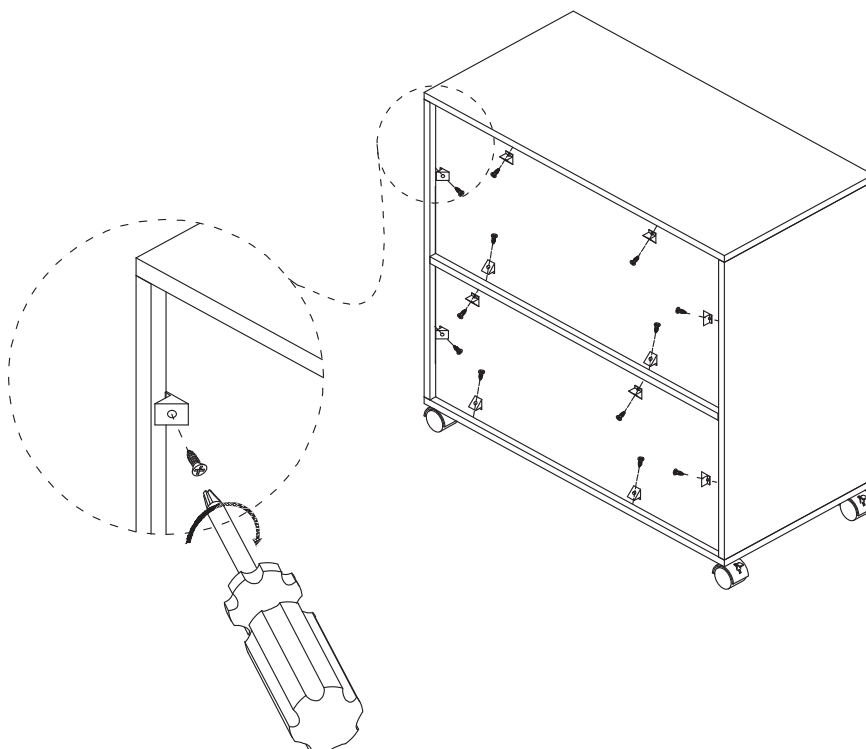

21

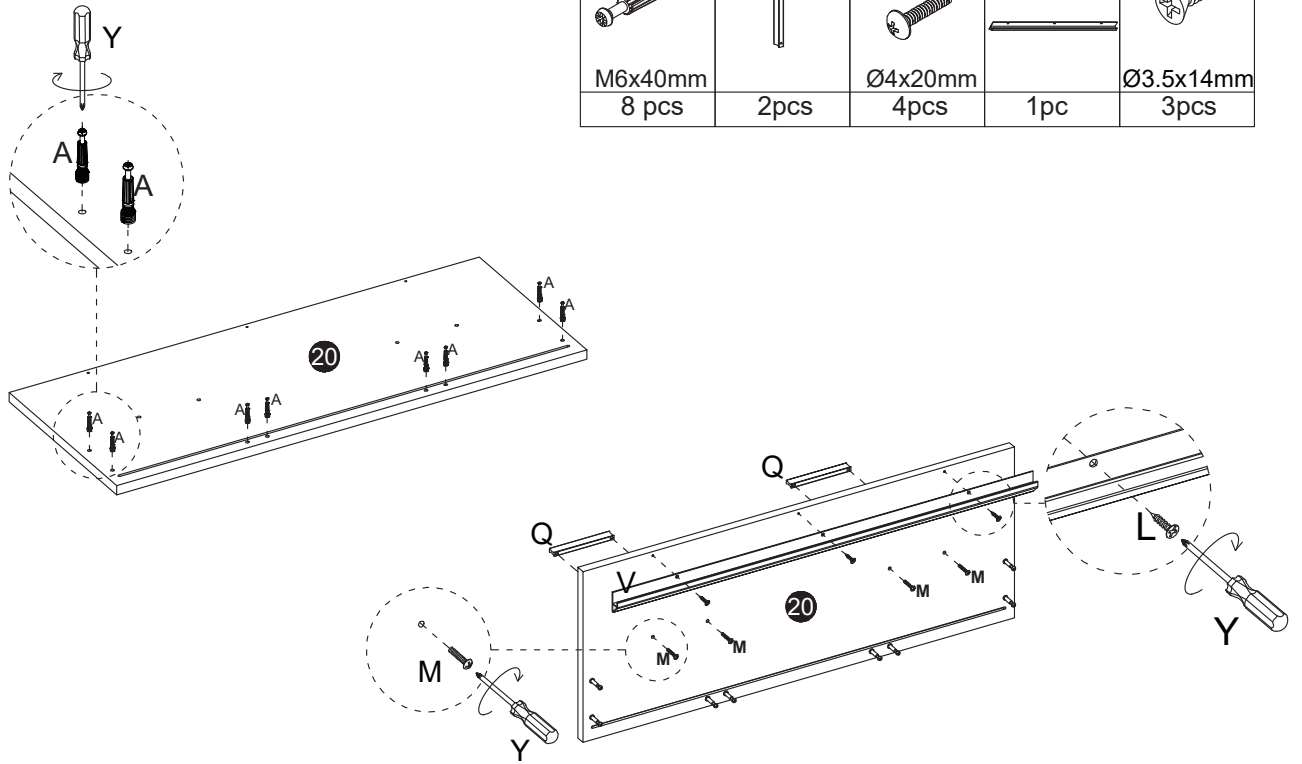

22

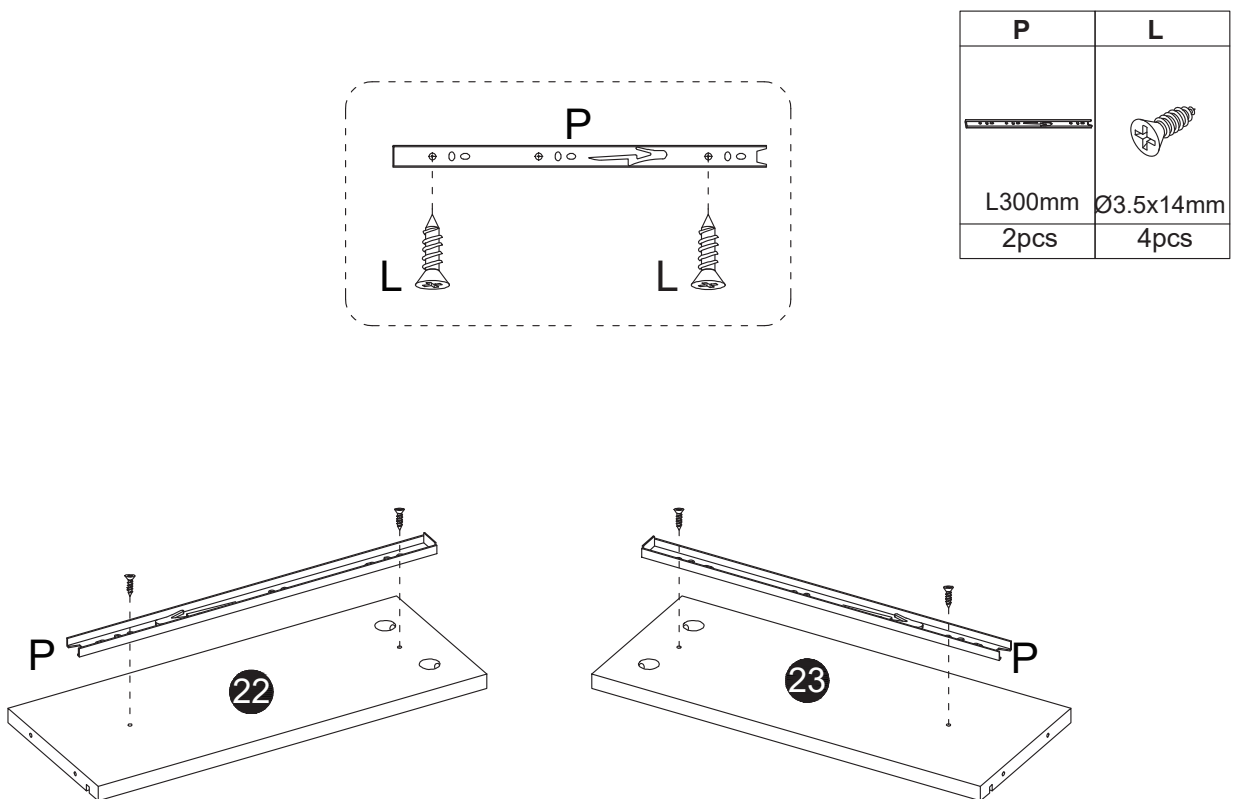

23

B

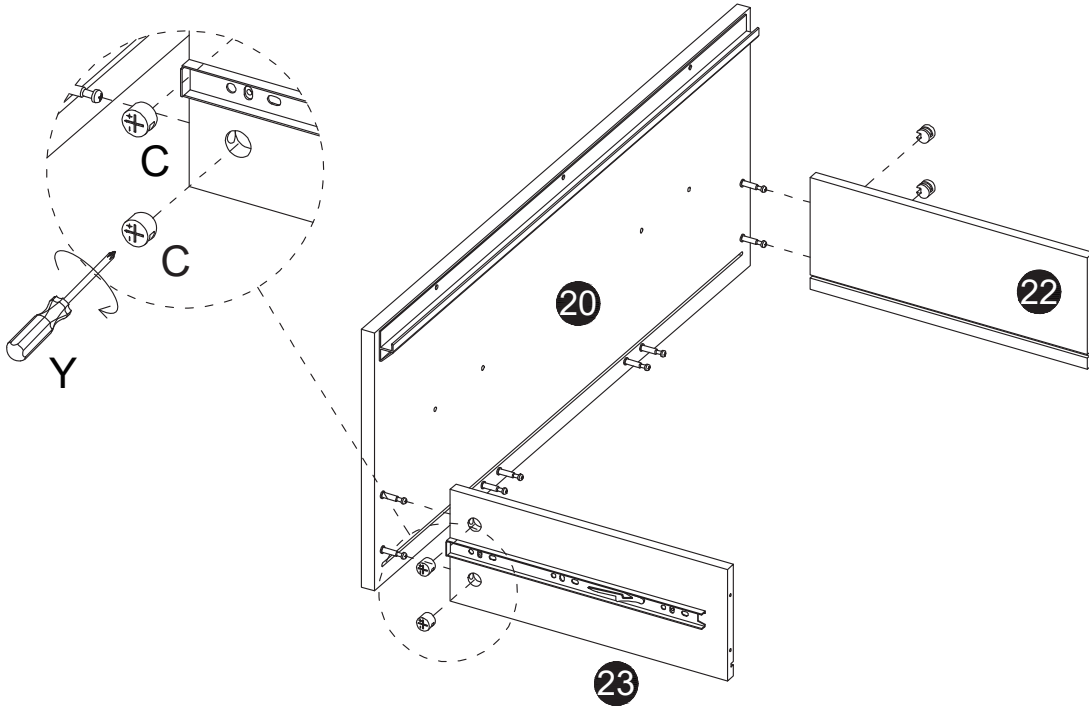
Ø15x12mm
4pcs



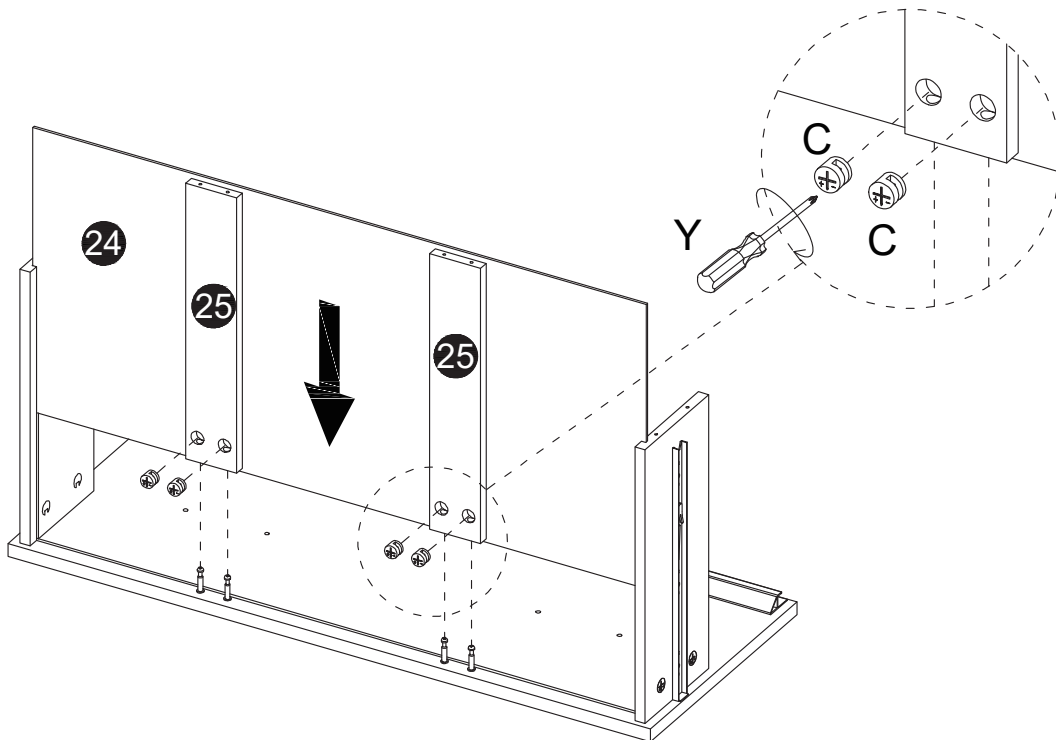

24

B

Ø15x12mm
4pcs

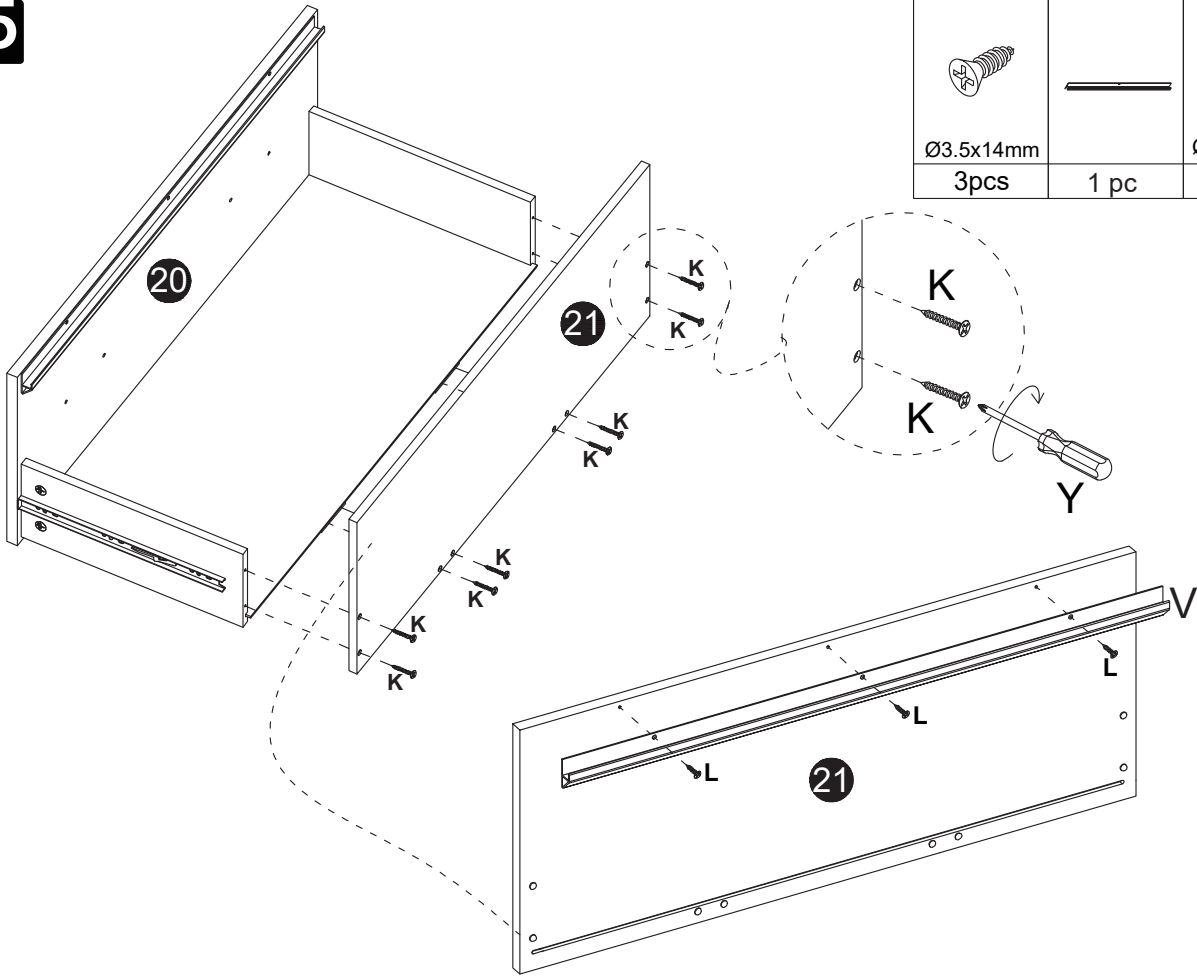

25

L	V	K
		
Ø3.5x14mm		Ø3.5x35mm
3 pcs	1 pc	8 pcs



26

U

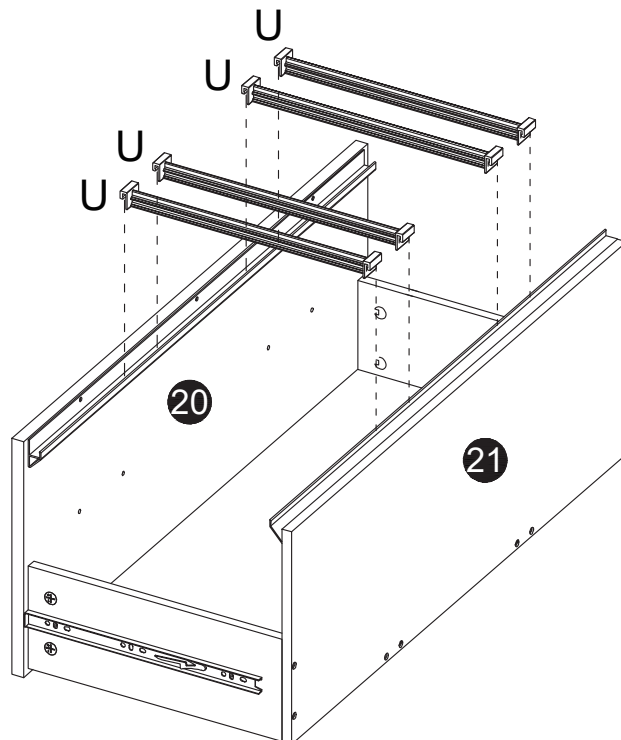
318x25x22mm
4 pcs

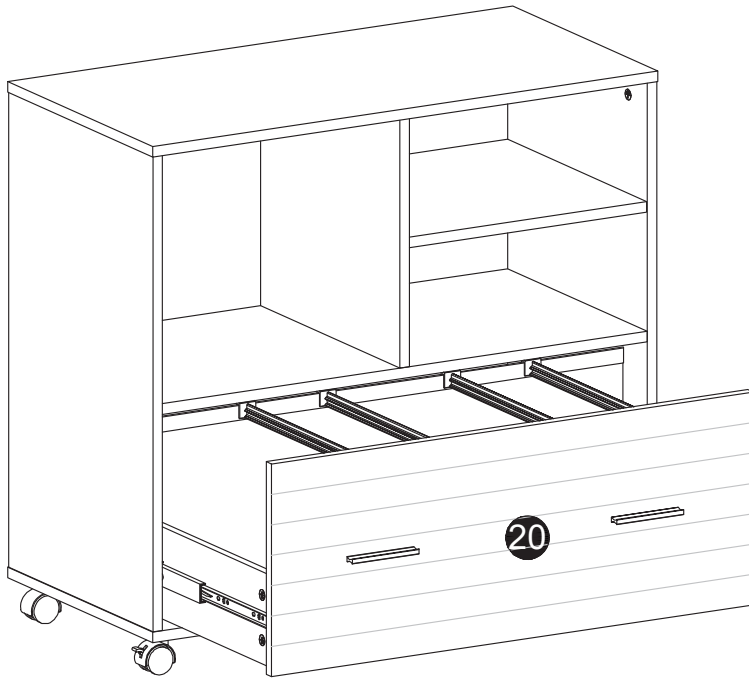

27

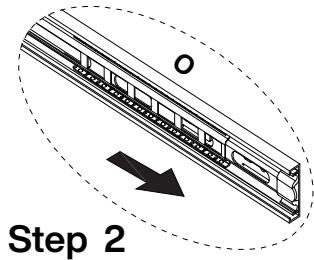

Step 1



Step 2

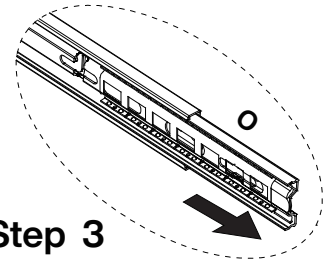

Step 3

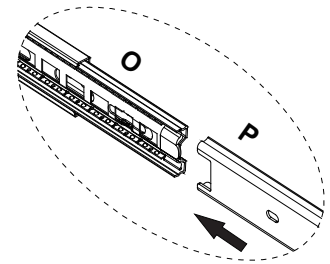

Before installation, slide the inner iron pieces of #O to the outermost side. Then align it with #P and gently push it inward to complete the slide installation.

28

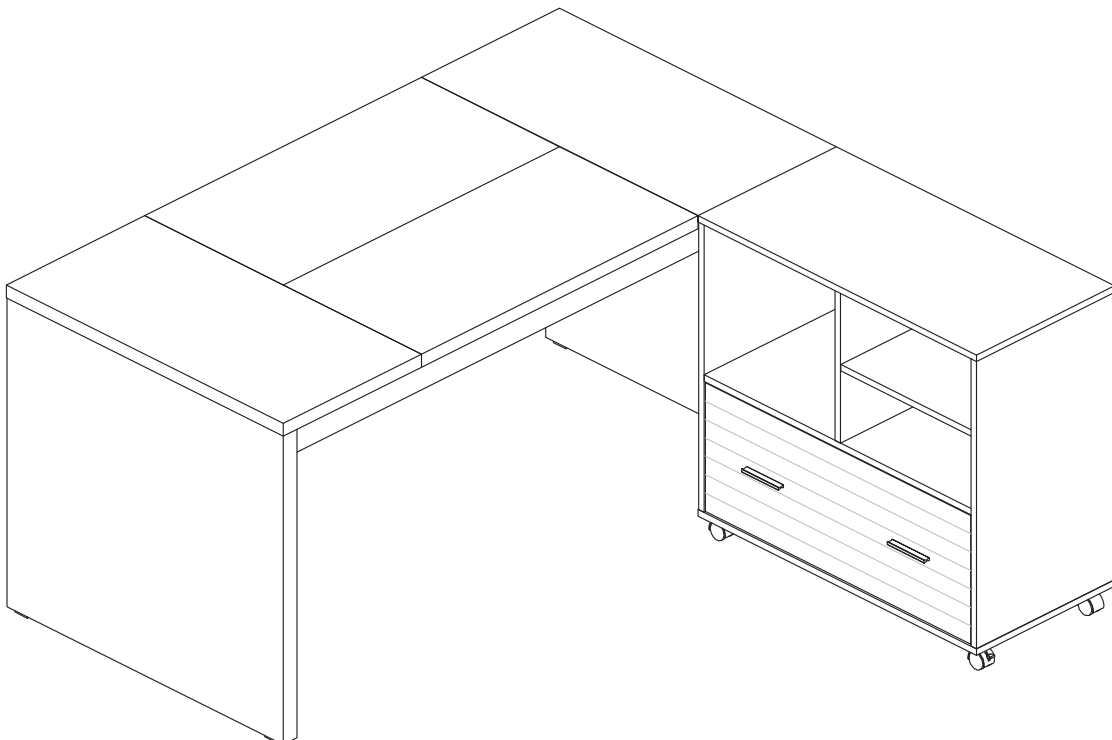

Thank you for your support!

