





Examine all packaging material for small parts that may have come loose during shipment. Periodic checks are recommended to insure that all components are in proper position, tight and free from damage. Keep this assembly instruction for future reference. Adult assembly is required.

CODE	QTY	HARDWARE	
1	12	1/4" x 15mm Allen Bolts	
2	16	Ø6.5 x 1.5mm Spring Washers	
3	16	Ø13 x Ø6.5 x 1.5mm Flat Washers	
4	1	Allen Wrench	
5	4	1/4" x 20mm Allen Bolts	

CODE	QTY	COMPONENTS	CODE	QTY	COMPONENTS
A	1	Left Leg	B	2	Right Leg
C	1	Seat Frame	D	1	Stretcher
E	1	Chair Back	B	F	Wood Seat

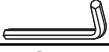

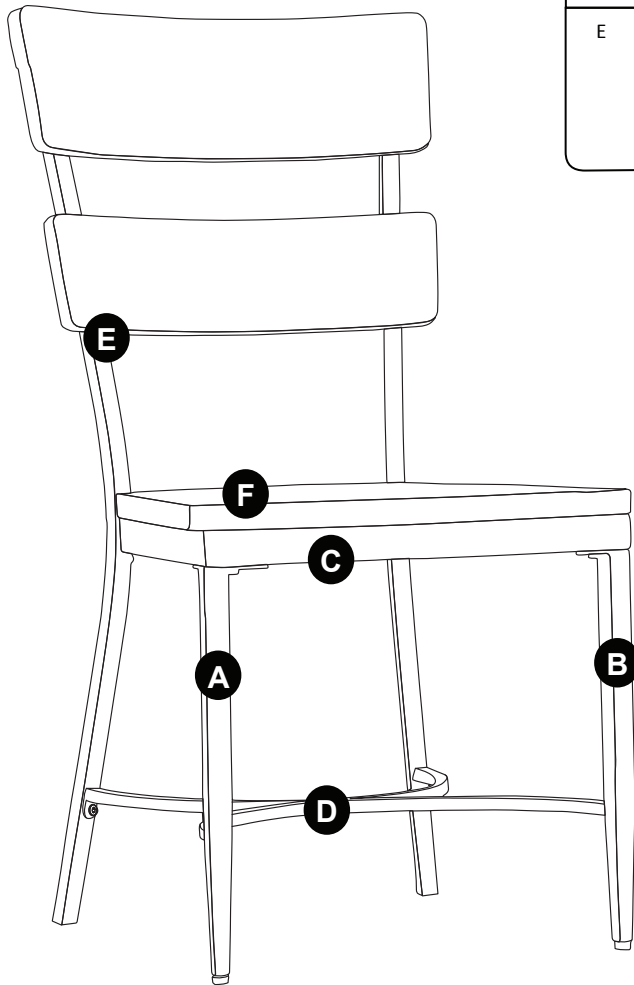
WARNING

- Do not let any sharp objects touch or rub the surface of the product.
- When assembling, do not let children play around the working area.
- Please confirm all parts are correct before starting the assembly process.
- Do not tighten all bolts and screws completely until the entire unit has been assembled and set up.
- Be careful if using power tools as they can over tighten screws and strip threads.

CARE & MAINTENANCE: The touch of a soft cloth is all the maintenance the finish will ever need. Please do not use harsh or abrasive cleaners for polishing, as they may cause damage to the finish. Periodic checks are recommended to make sure that all hardware is securely tightened.

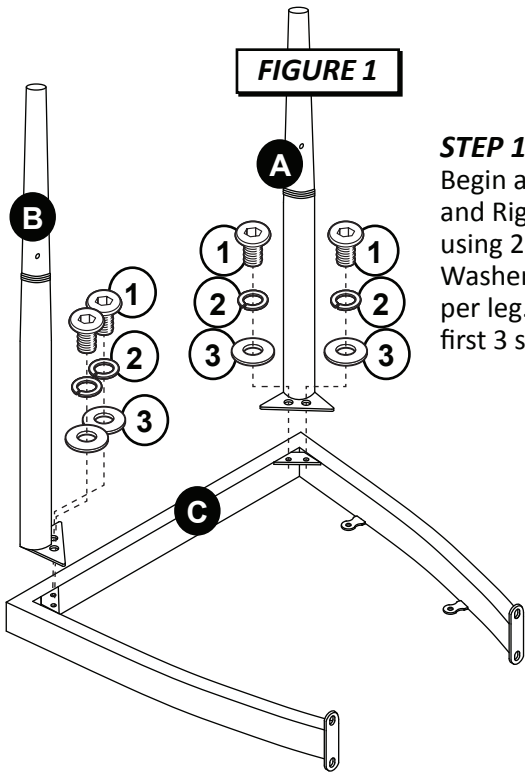

FIGURE 1

STEP 1 - Figure 1

Begin assembly by attaching Left (A) and Right (B) Legs to Seat Frame (C) using 2 Allen Bolts (1), 2 Spring Washers (2) and 2 Flat Washers (3) per leg. Only hand tighten bolts for first 3 steps.

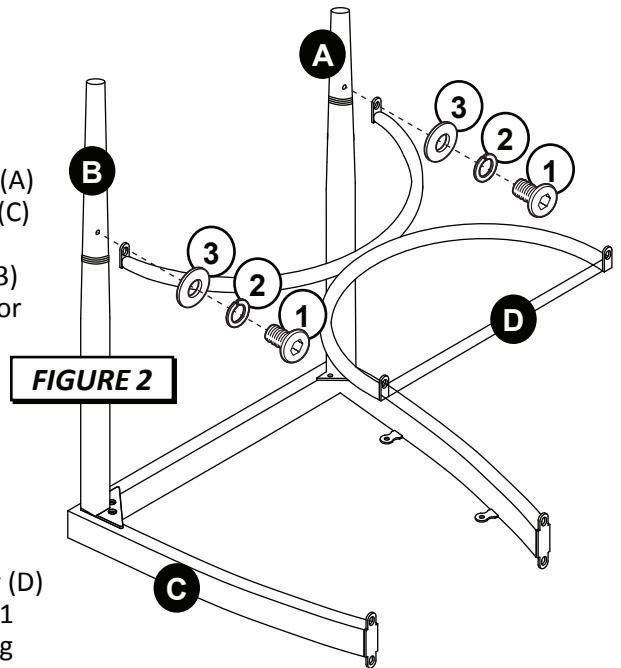

FIGURE 2

STEP 2 - Figure 2

Next attach Stretcher (D) to Legs (A & B) using 1 Allen Bolt (1), 1 Spring Washer (2) and 1 Flat Washer (3) per leg.

STEP 3 - Figure 3

Next attach Seat Frame (C) to Chair Back (E) using 2 Allen Bolts (1), 2 Spring Washers (2) and 2 Flat Washers (3) per leg and attach Stretcher (D) to legs on Chair Back (E) using 1 Allen Bolt (1), 1 Spring Washer (2) and 1 Flat Washer (3) per leg.

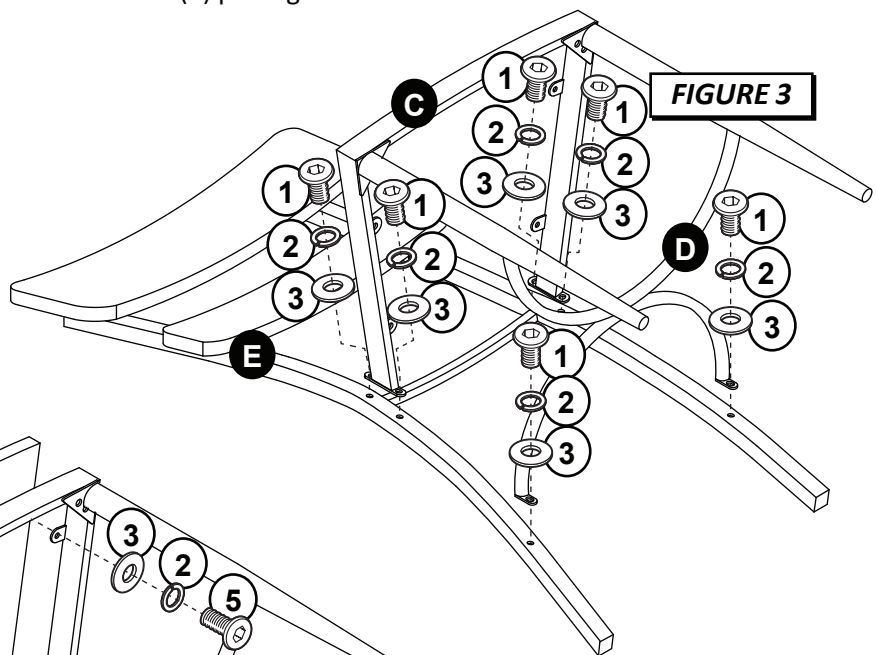

FIGURE 3

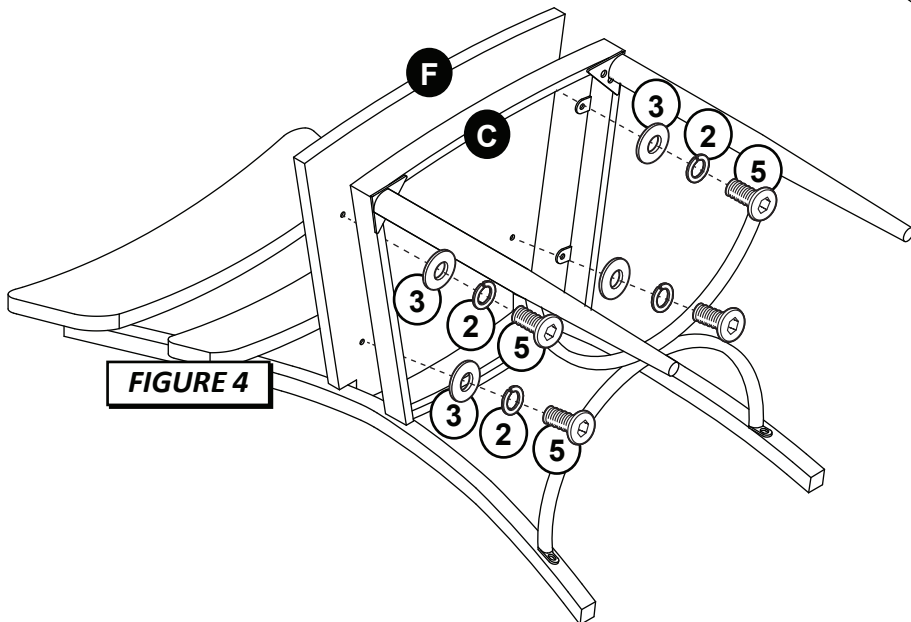

FIGURE 4

STEP 4 - Figure 4

Finally, attach Wood Seat (F) to Seat Frame (C) 4 Allen Bolts (1), 4 Spring Washers (2) and 4 Flat Washers (3). Tighten all bolts from all steps using Allen Wrench (4). The assembly is now complete.