

Nesting Round Coffee Table

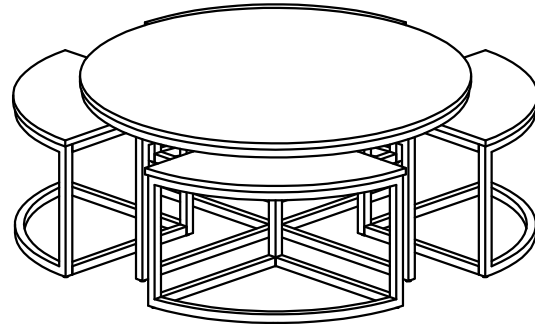

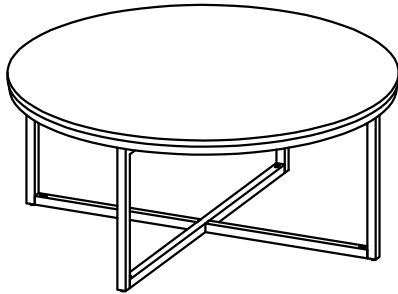



Note: Illustration shown w/4 Optional Wedges underneath.

Thank you for purchasing the Nesting Round Coffee Table. We have found it helpful to have a second person present during the assembly process.

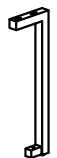
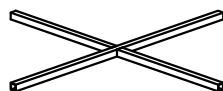
Round Coffee Table Assembly Instructions

Parts

NO.	DRAWING	DESCRIPTION	QTY
A		TABLE TOP	1
B		TABLE LEG	4
C		X-FRAME	1

NO.	DRAWING	DESCRIPTION	QTY
D		M6x40MM BOLT	8
E		M6x20MM BOLT	4
F		FLAT WASHER	12
G		ALLEN KEY	1

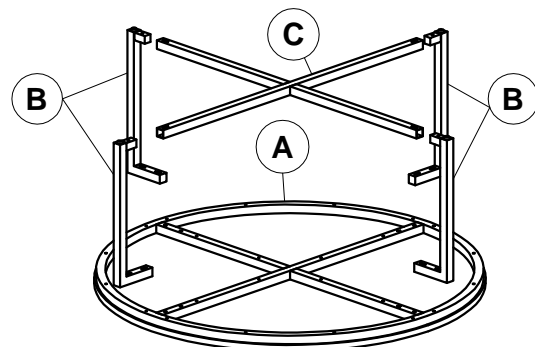

Step 1

Read through these instructions thoroughly before beginning assembly. We have found this to be of great value when assembling this product.

Step 2

Remove all parts and hardware from packing material. Wooden pieces should be placed on a non abrasive surface to prevent damage to the finish

Step 3

Attach Table Leg Assembly (B) to X-Frame (C) using 4-M6x20MM Hex Bolts (E) and Flat Washer (F).
NOTE: DO NOT TIGHTEN FIRMLY AT THIS TIME !

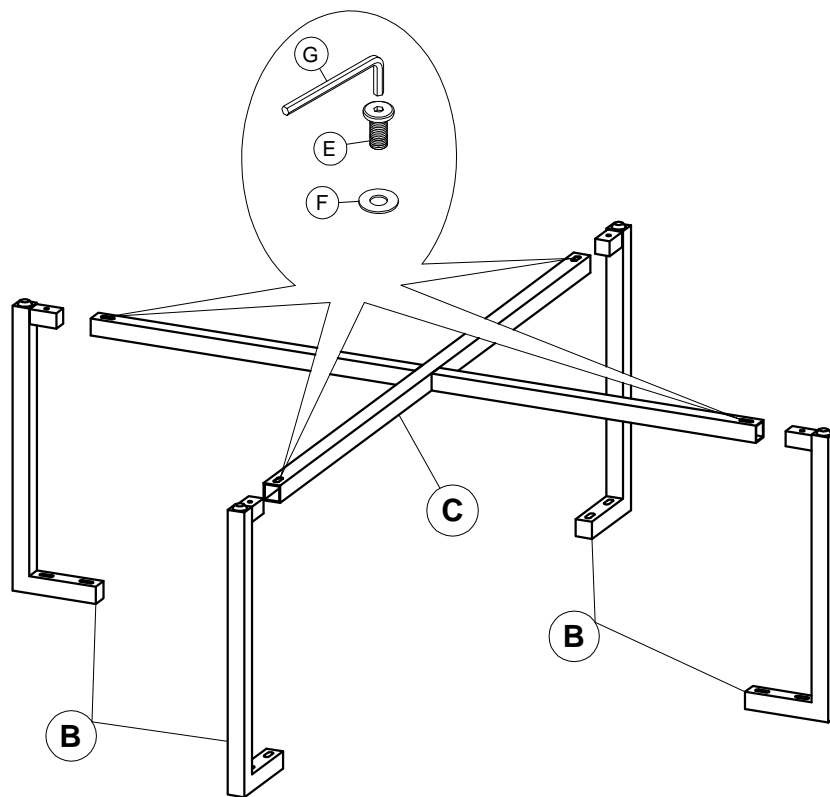

Step 4

Lay Table Top Assembly (A) upside on a non abrasive surface. Attach Leg-Frame using 8-M6x40MM Hex Bolts (D) and Flat Washer (F). NOTE: TIGHTEN ALL BOLTS AT THIS TIME !

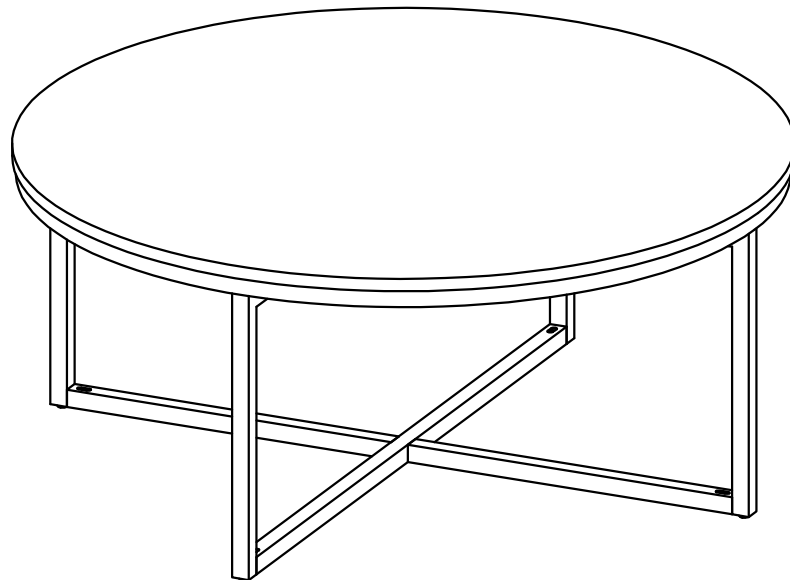
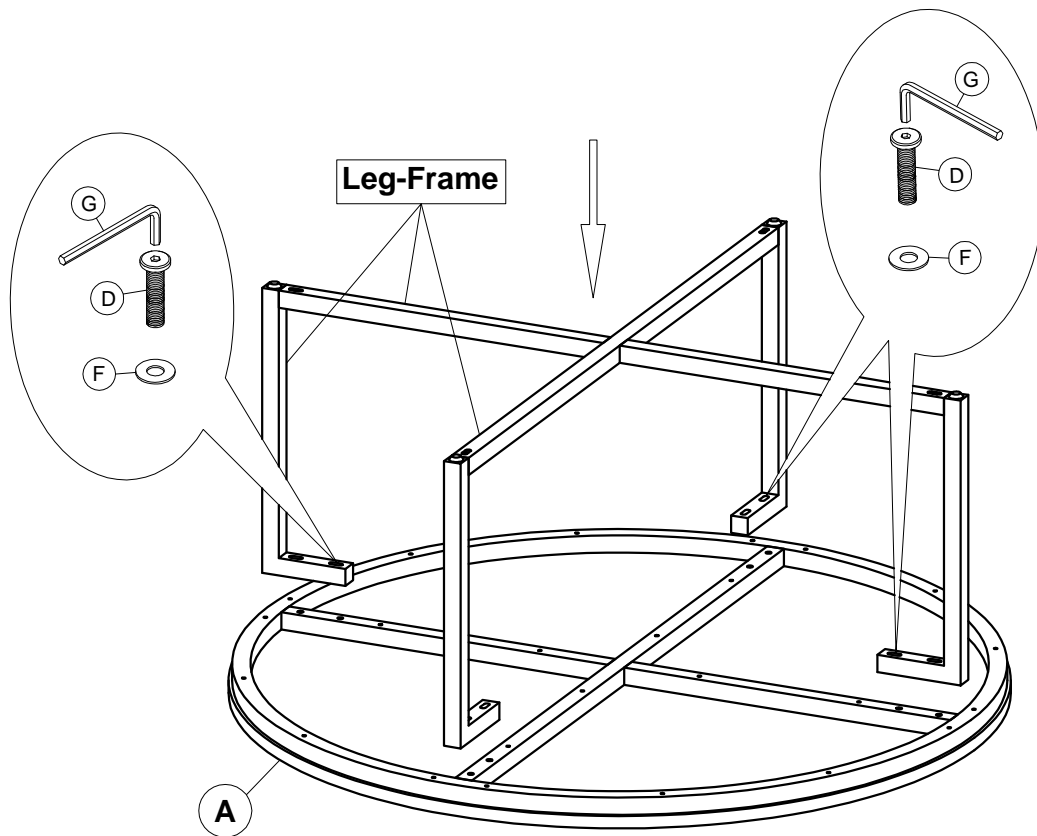

CARE

Clean with a non abrasive cloth using a mild soap. Make sure to wipe dry.
