

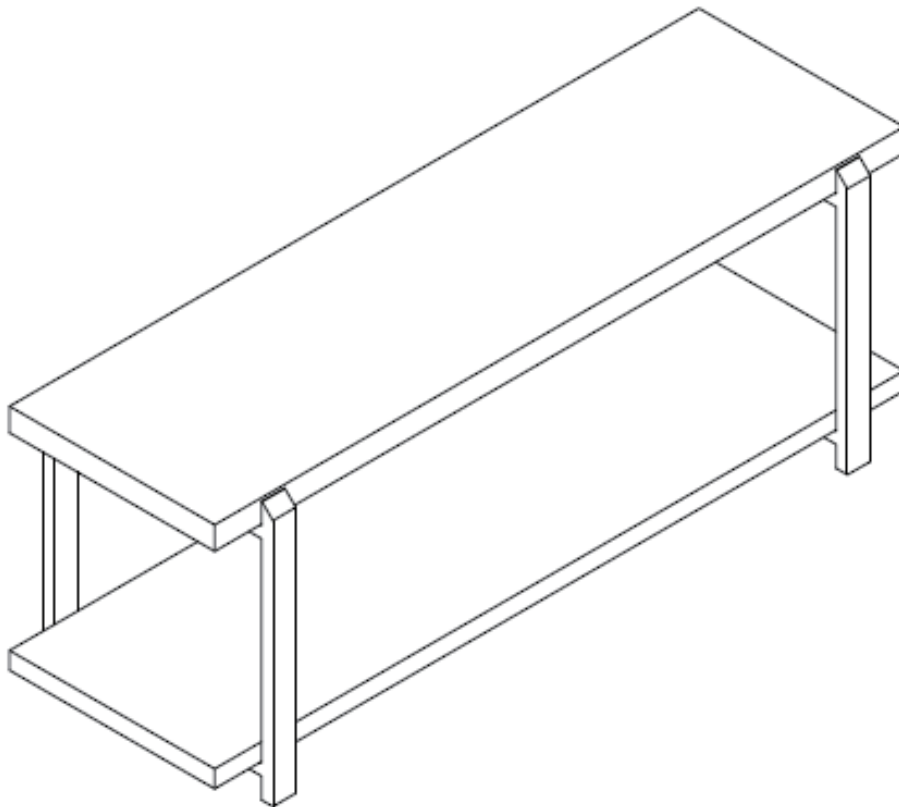

ASSEMBLY INSTRUCTION

Bench



Part Identification

 While not all parts are labeled, some of the parts will have a label to help distinguish similar parts from each other. Use this part identification to help identify similar parts.

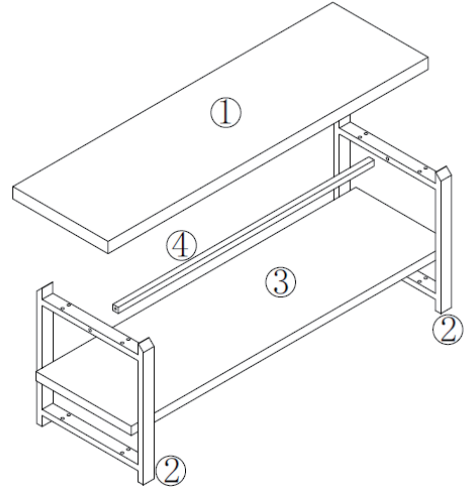
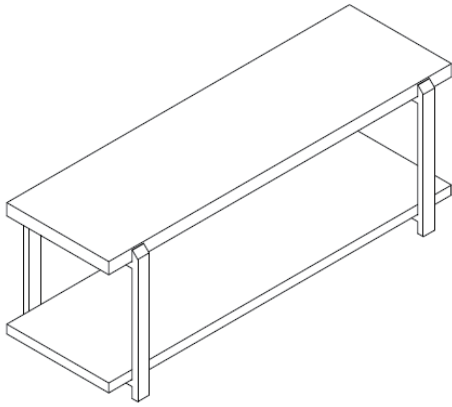

①

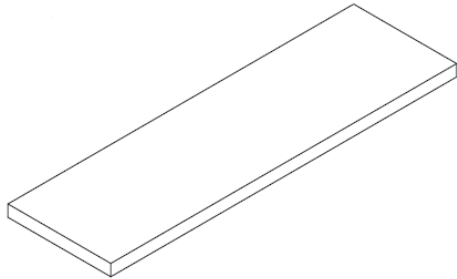

Thickness: 1.58 inch

Table Top 1 pcs

②

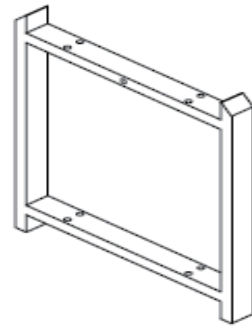

Metal Frame 2 pcs

③

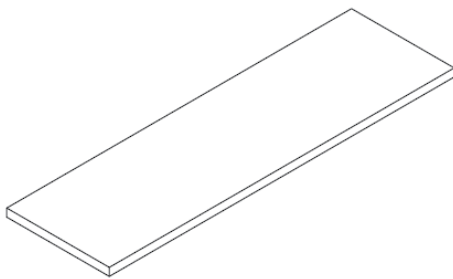

Thickness: 1.18 inch

Shelf 1 pcs

④

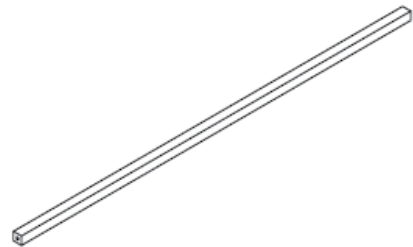

Metal Tube 1 pcs

A



Allen Key 1PC

B



M6*35 mm
Short Screw 16 PCS

C



M6*60 mm
Long Screw 2 PCS

Step 01

NOTE: DO NOT fully tighten all bolts at this step.

↑ Lay the Metal Frames(②) Parallel to each other on a clean smooth surface such as carpet or cardboard. Fasten Metal Legs(②) to the Metal Tube(④) by using two Long Screws(C) with Allen Key(A).

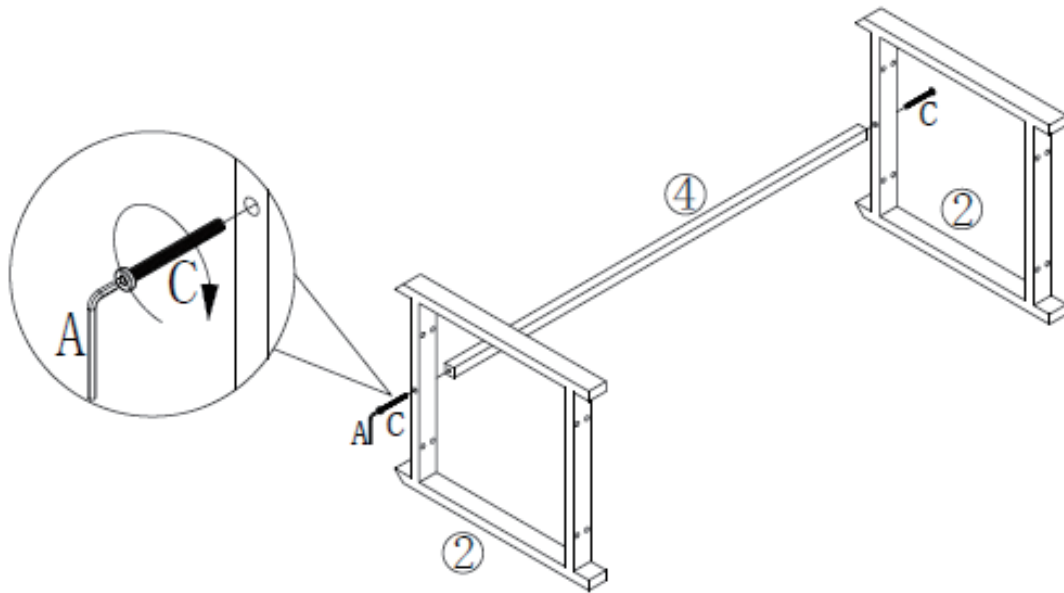

Step 02

NOTE: If holes don't align, loosen all bolts and adjust the holes slightly. After all holes are aligned, fully tighten all bolts.

2.1 Attach Table Top (①) and Shelf(③) into metal frames(②) with Short Screws(B) by Allen key(A). Do not fully tighten all bolts until all parts are in place.

2.2 Tighten all bolts when all parts are in place. Flip the desk upright with the help of another person.

