

ASSEMBLY INSTRUCTIONS

FULL BED

THANK YOU FOR PURCHASING THIS QUALITY PRODUCT. READ THESE INSTRUCTIONS CAREFULLY. SEE PARTS LIST AND HARDWARE LIST FOR GUIDANCE, BE SURE ALL PARTS ARE PRESENT PRIOR TO ASSEMBLY.

- CAUTIONS:
1. DO NOT FULLY TIGHTEN BOLTS UNTIL ALL BOLTS ARE IN PLACE AND READY FOR ASSEMBLY.
 2. DO NOT OVER TIGHTEN BOLTS TO AVOID CAUSING DAMAGE TO THE THREADS.
 3. KEEP ALL PARTS AND HARDWARE OUT TO REACH OF CHILDREN.

TOOLS NEEDED : SCREWDRIVER (NOT PROVIDED)

PARTS LIST		
ITEM	DESCRIPTION	QTY
A	HEADBOARD (1/2)	1 PC
B	FOOTBOARD (2/2)	1 PC
C	SIDE RAIL (2/2)	2 PCS
D	CENTER SUPPORT (2/2)	1 PC
E	CENTER SUPPORT LEG (2/2)	3 PCS
F	BED LEG (STRAIGHT) (2/2)	2 PCS
G	BED LEG (SHAKER) (2/2)	2 PCS
H	SLATS (1/2)	1 SET

HARDWARE LIST		
ITEM	DESCRIPTION	QTY
1	CSK SCREW M4 x 38mm (2/2)	9 PCS
2	ALLEN KEY M5 (2/2)	1 PC

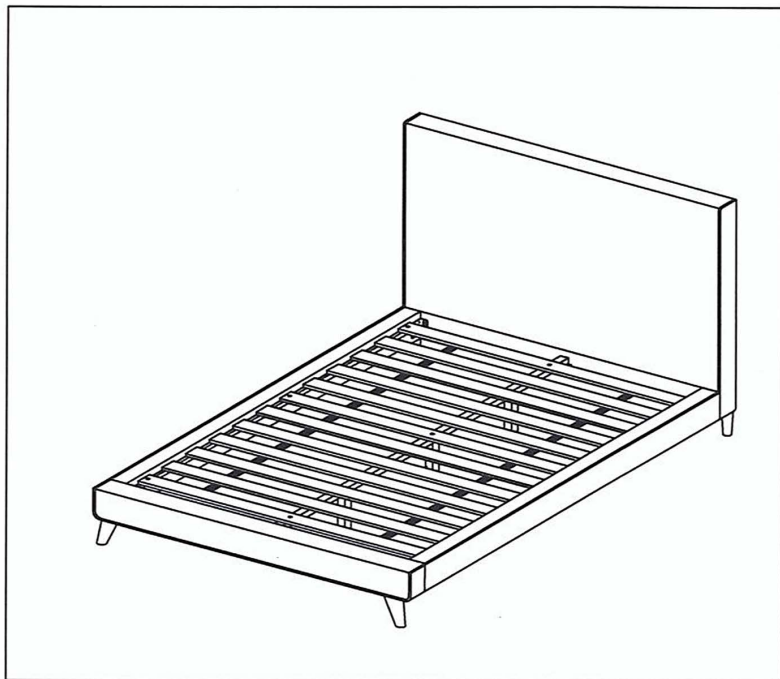

STEP 1

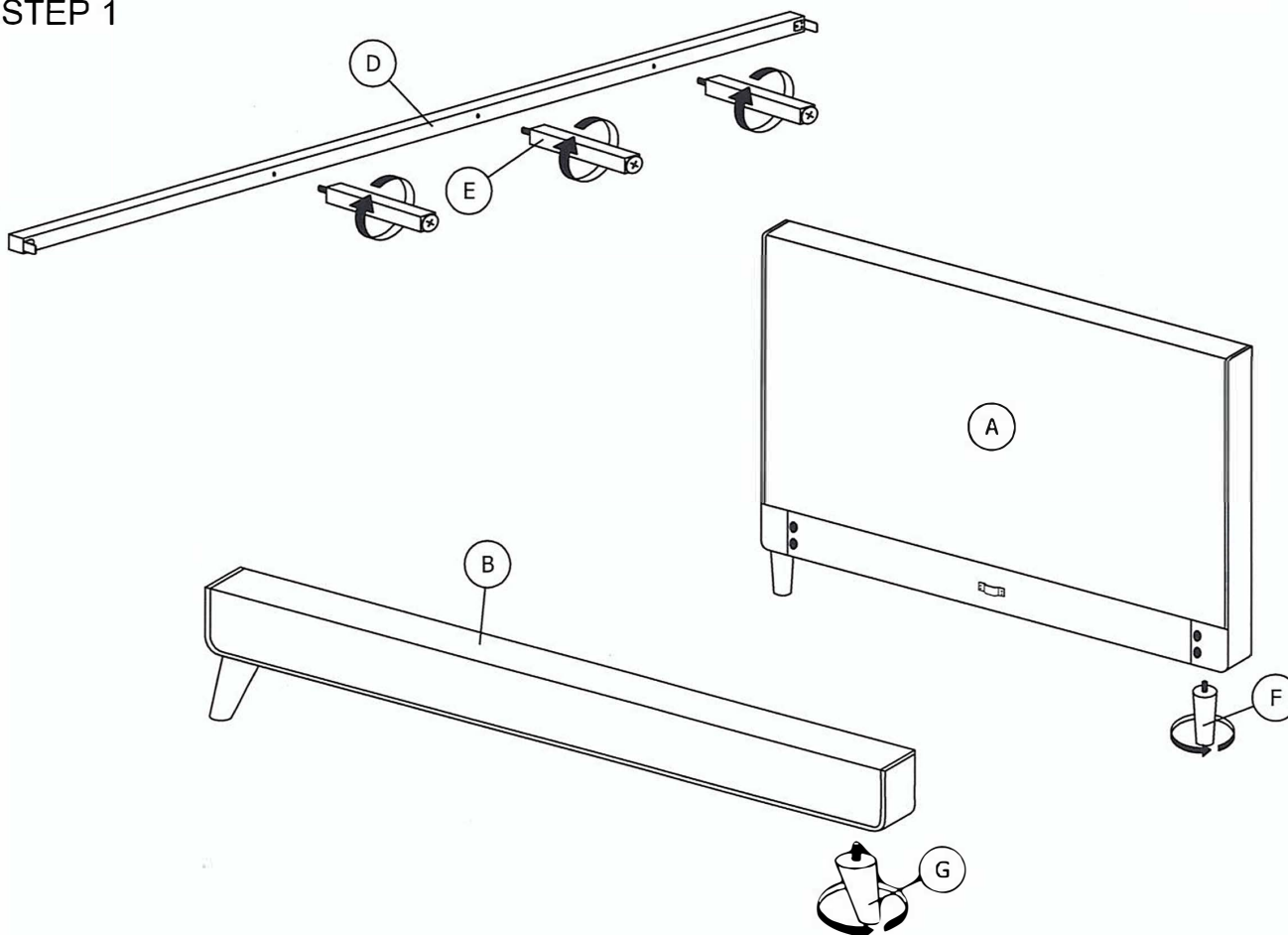

STEP 2

STEP A : Use the ALLEN KEY M5 (2) to turn loose all the JCBB BOLT & WASHER and don't pull out.
Hang the SIDE RAILS (C) to HEADBOARD (A) & FOOTBOARD (B).

STEP B : Tighten all the JCBB BOLT & WASHER after assembly the SIDE RAILS (C).

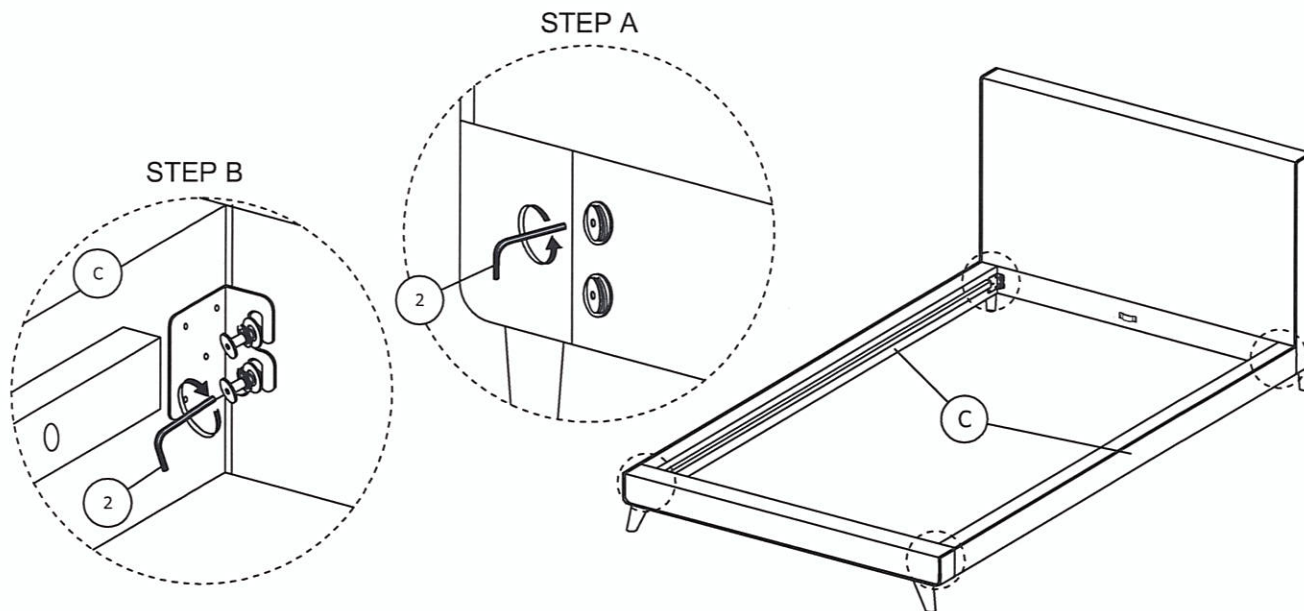

STEP 3

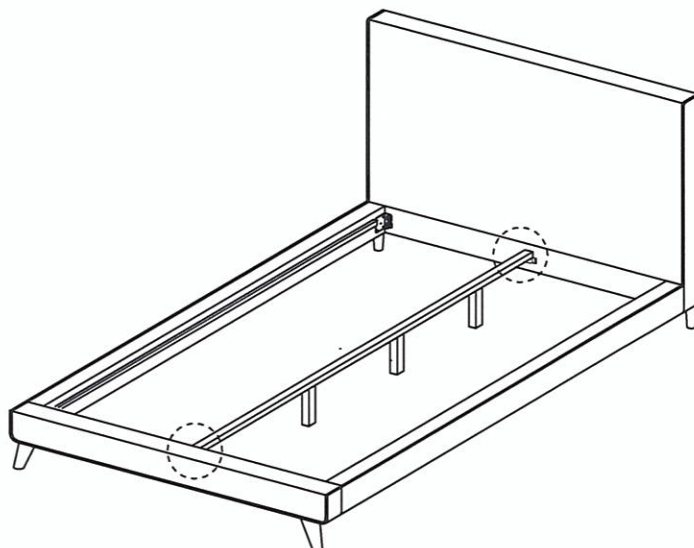
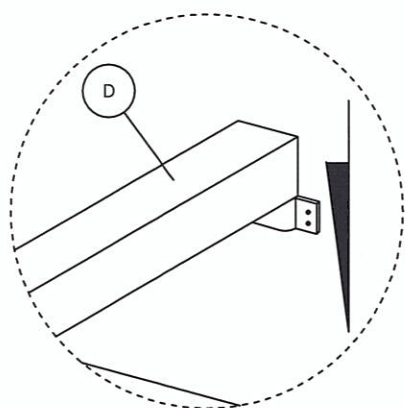

STEP 4

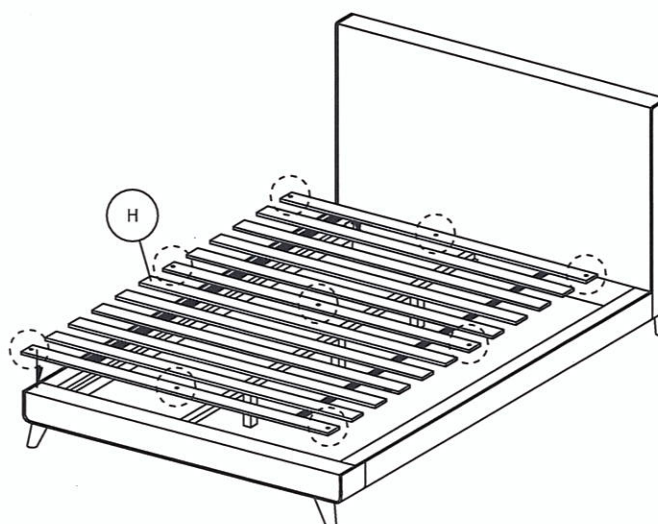
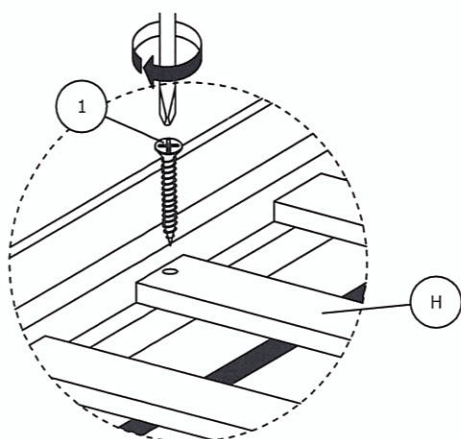

Assembled completed

* When moving bed position, the center support leg levelers must be adjust up right to avoid breakage of the leg and center support.