

# Signature Plus/Dover/Charleston Assembly Instructions

## General Information:

- Read instructions carefully before beginning assembly.
- Identify each component from material list.
- Do not use excessive force when assembling components.
- To clean this product, for best results use a soap solution and high-pressure water.

## Materials List:

Part #	Description	Quantity
1	Decorative Post	1
2	Newspaper Holder	1
3	Planter (Planter only comes with the Signature Plus)	1

### Newspaper Holder Hardware Pack Includes:

4	1/4" x 3" galvanized lag bolt	2
5	#10 x 3" steel screw	2
6	Plastic snap cap	2

### Planter Hardware Pack Includes:

4	1/4" x 3" galvanized lag bolt	1
5	#10 x 3" steel screw	1
6	Plastic snap cap	1
7	5/16" galvanized flat washer	1

- 8 4x4 wood post - **not included**  
*4x4 actual dimensions are 3.5in x 3.5in*  
*72in length is recommended*

### Tools Required:

- Cordless drill
- Phillips drill bit
- 7/16" socket wrench
- Tape measure
- Level
- Shovel

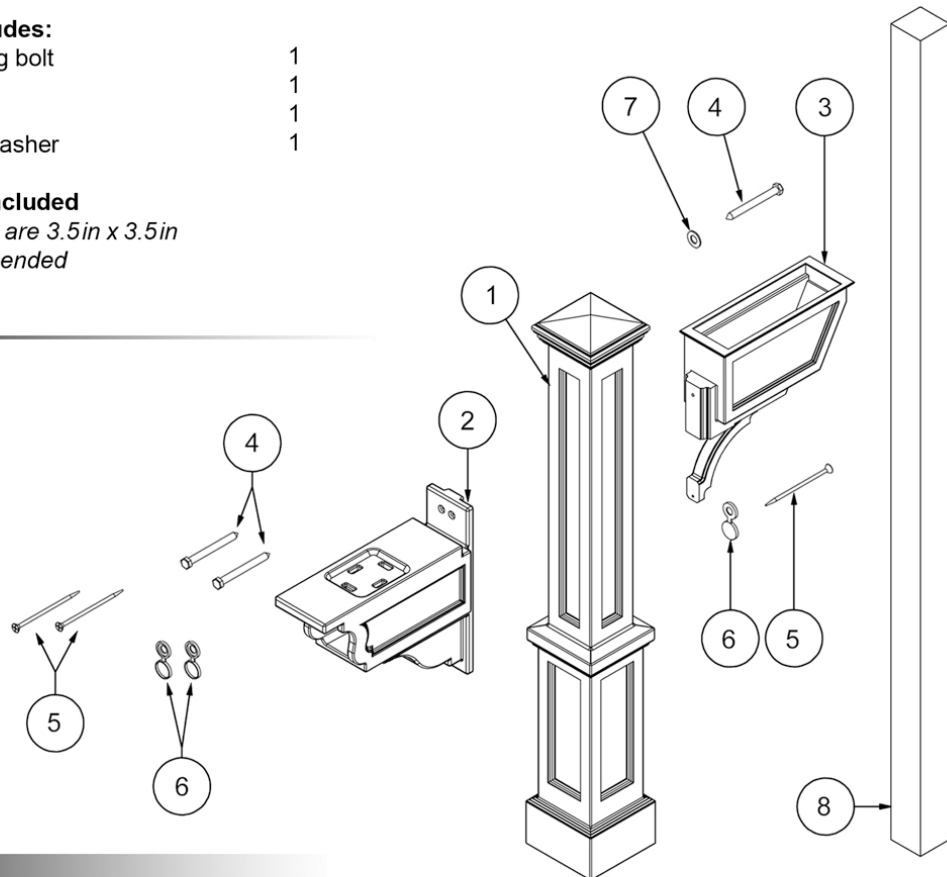
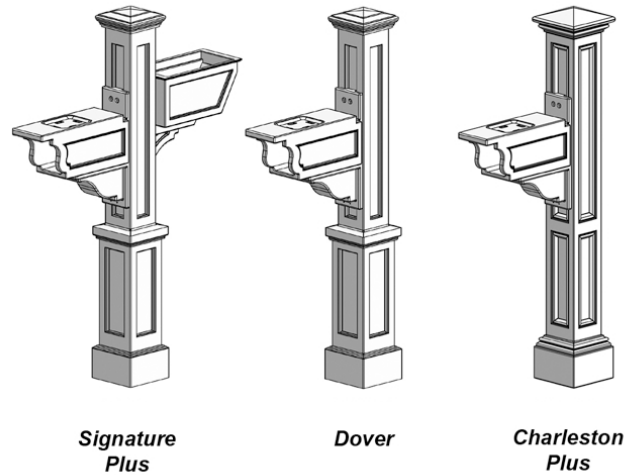

## IMPORTANT NOTE:

- 4x4 wood post, mailbox, and mailbox mounting hardware NOT included with any Mayne mail posts
- Medium mailbox recommended (up to 12lbs), heavier mailboxes can be reinforced by securing 2 screws through the back of the mailbox directly into the post

# Assembly Instructions

1.

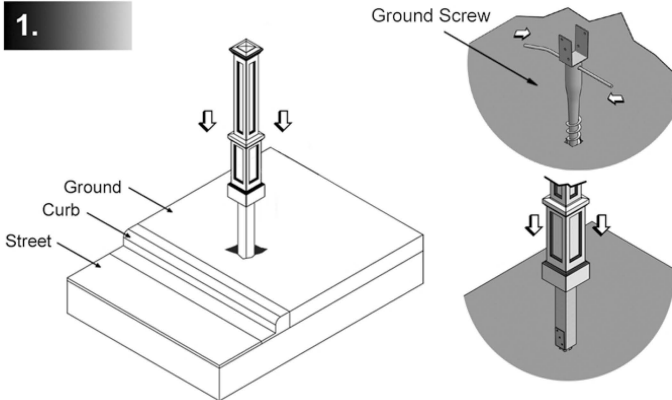

Dig a 24" deep hole in the desired location and insert a 4x4 wood post. Leave 48" exposed above ground. Fill the hole with pre-mix concrete (not included) and level the wood post. Once the concrete has cured, slide the decorative post (part 1) over the wood 4x4 ensuring that the base sits flush with the ground.

**Optional Ground Screw:** Twist the screw into the ground and attach a 4x4 post (approx. 48" length, not included) with the 5x lag bolts provided. Slide the decorative post over the 4x4.

2.

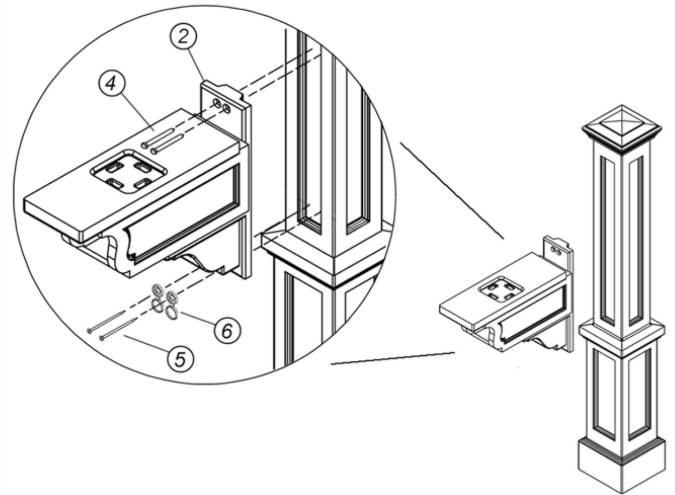

Secure the paper holder arm (part 2) to the decorative post (part 1) using two 3" lag bolts (part 4) for the top and two 3" screws (part 5) in the bottom. Plastic snap caps (part 6) are provided to cover the screw heads.

3.

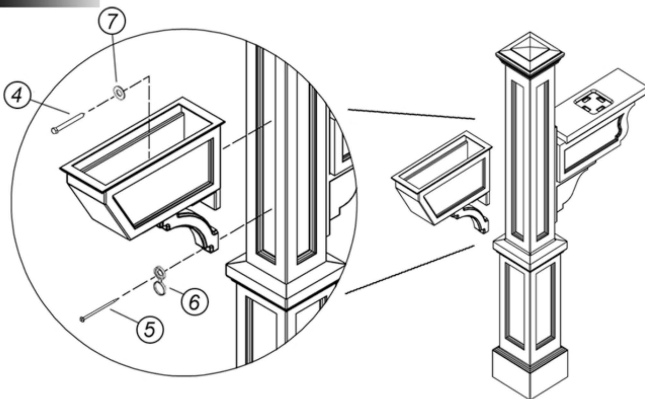

Using the pilot holes provided, fasten the planter (part 3) to the post as shown. Use one 3" lag bolt (part 4) and washer (part 7) in the top part of the arm and one 3" screw (part 5) for the bottom. A snap cap (part 6) is provided to cover the screw head.

**NOTE:** Planter installation only applies to the Signature Plus. To continue with Dover & Charleston installations see STEP 4.

4.

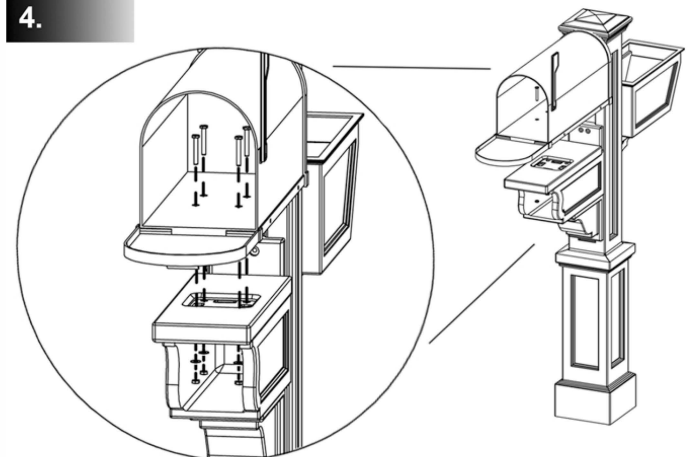

Pre-drill 4 holes with a 3/8" drill bit through the mailbox and paper holder arm as shown above. Using a nut, bolt, and washer combination secure the mailbox to the arm and tighten. 2" bolts are recommended (mailbox and mailbox mounting hardware not included). Heavier boxes can be reinforced by securing 2 screws through the back of the mailbox directly into the post.