

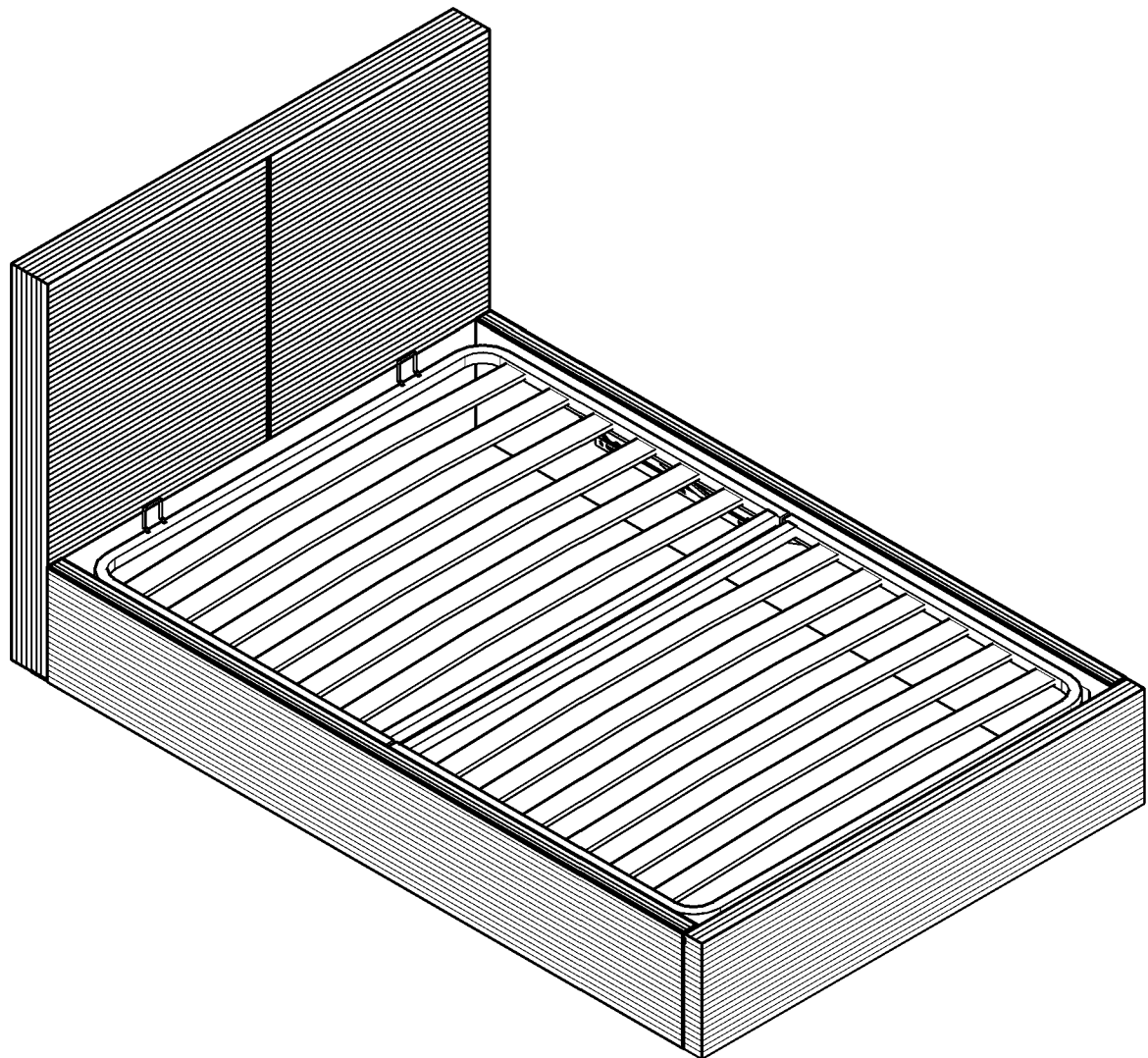

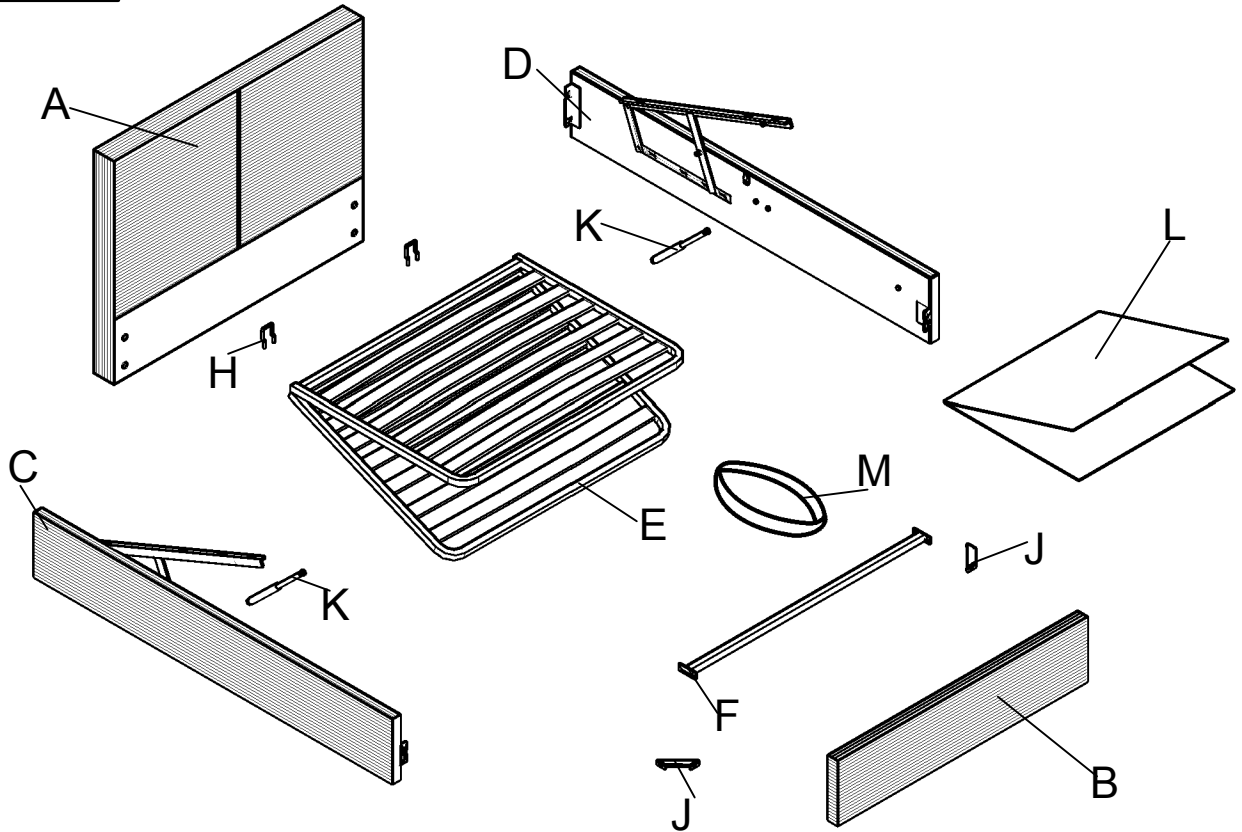

# ASSEMBLY INSTRUCTION





## PART LIST



## HARDWARE LIST

Label	Picture	Description	Qty	Label	Picture	Description	Qty
1		Bolt M8x20	12	3		Nut M8	8
2		Bolt M8x40	8	4		Foam Pad	6

## TOOL list

Label	Picture	Description	Qty
5		Allen key M5 M6	2
6		Spanner M12 M13	2

1

8PCS



Bolt M8x20

Step 1

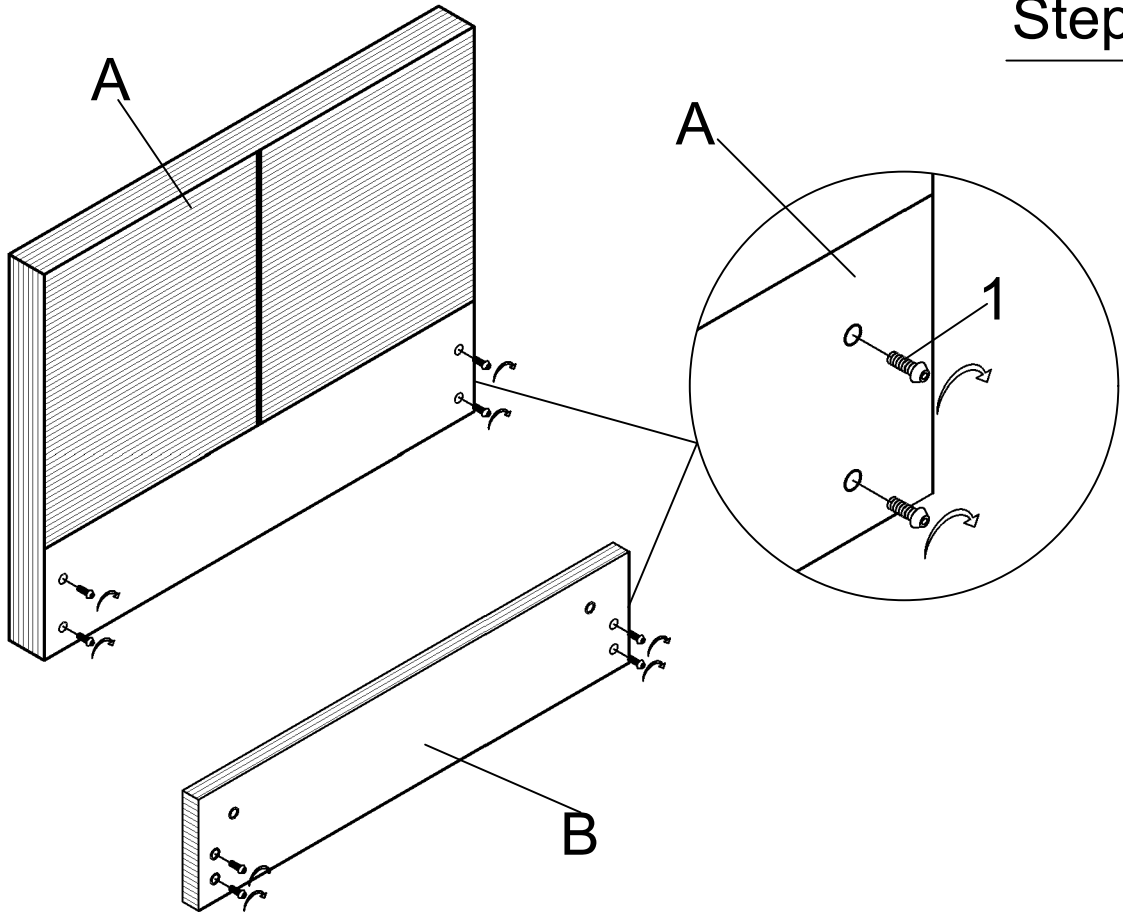

5



Allen key M6

Step 2

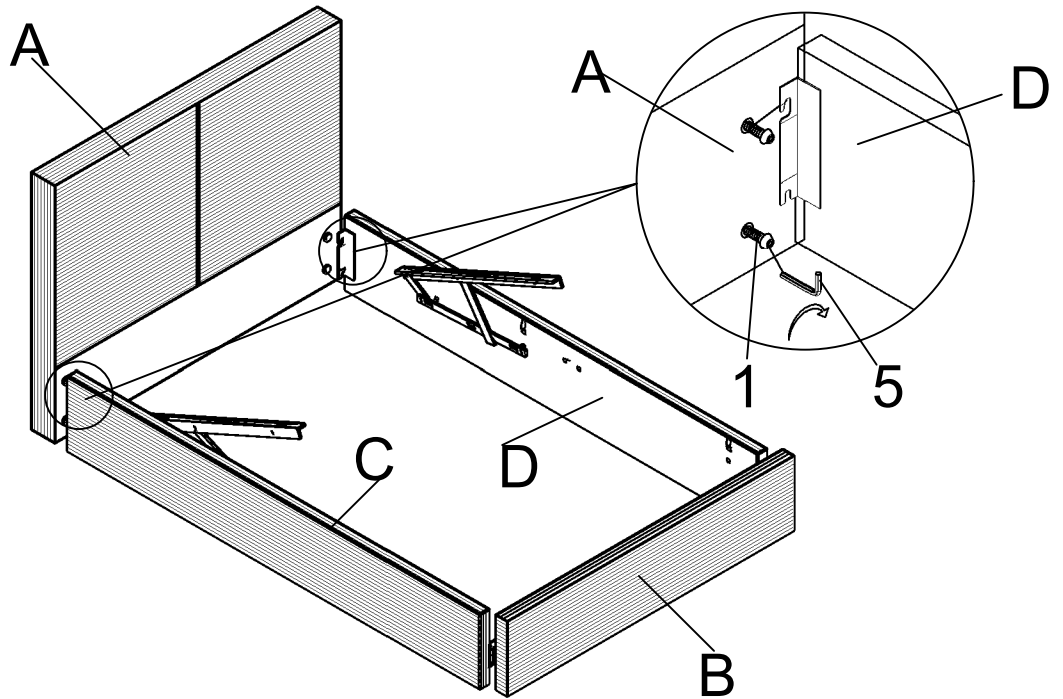

5



Allen key M6

### Step 3

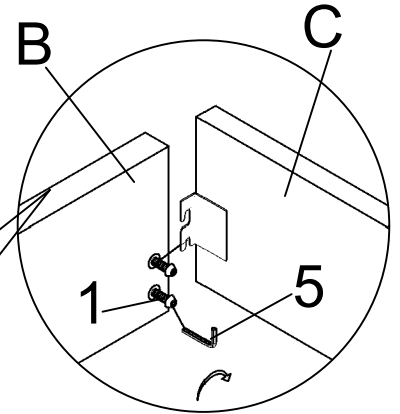
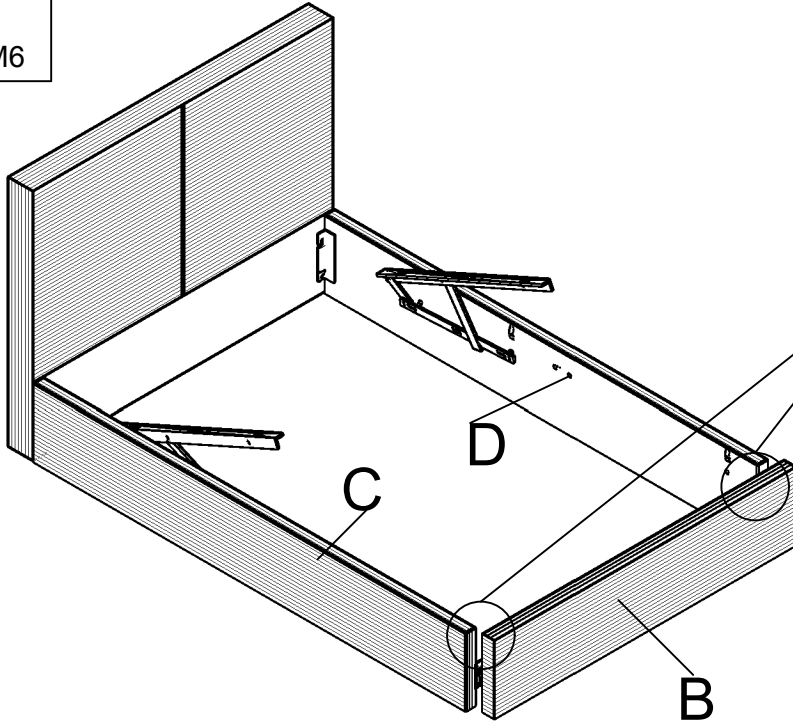

J

2PCS

1

4PCS



Connection Plate

Bolt M8x20

### Step 4

5



Allen key M6

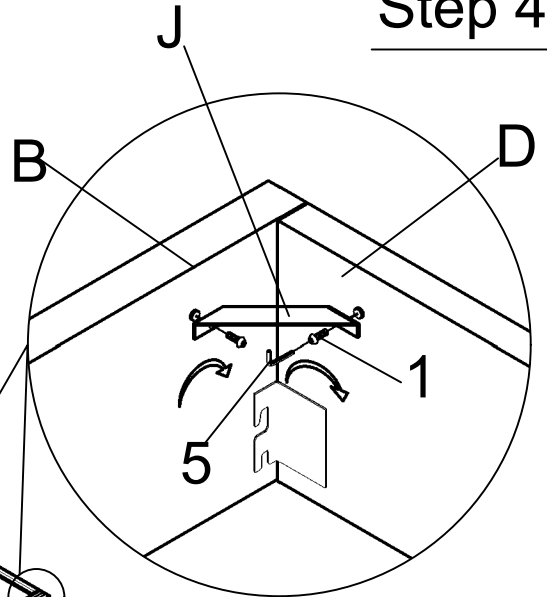
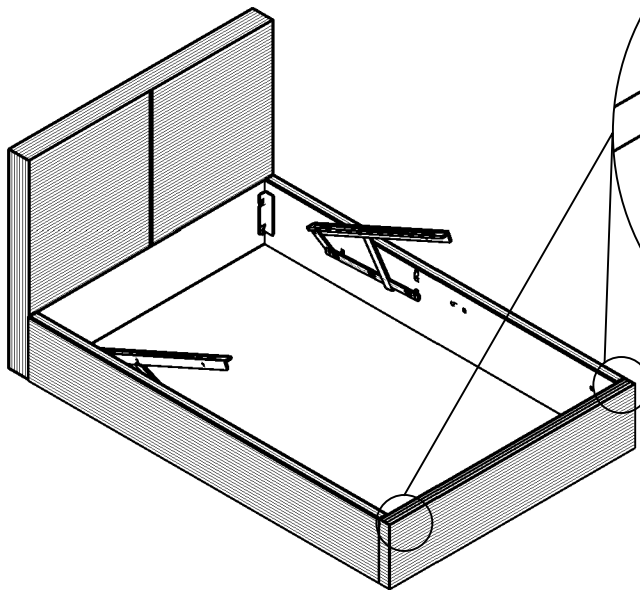

5



Allen key M5

# Step 5

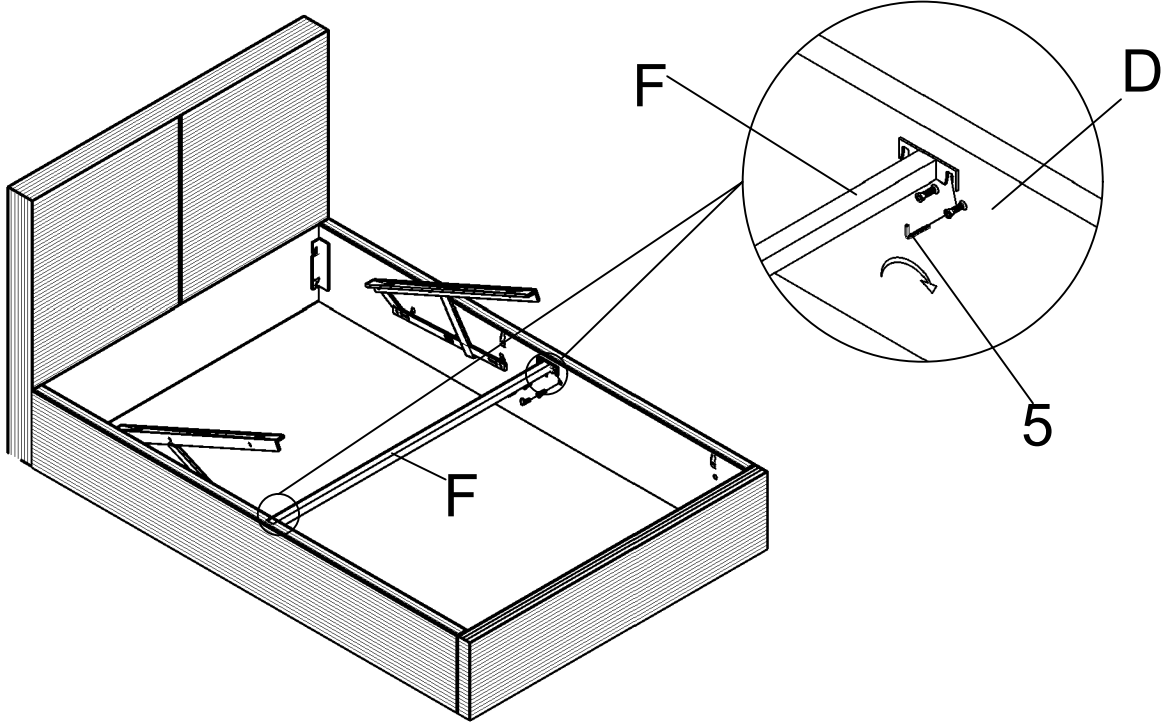

2

8PCS



Bolt M8x40

3

8PCS



Nut M8

5



Allen key M6

6



Spanner M12

# Step 6

Headbaord Side

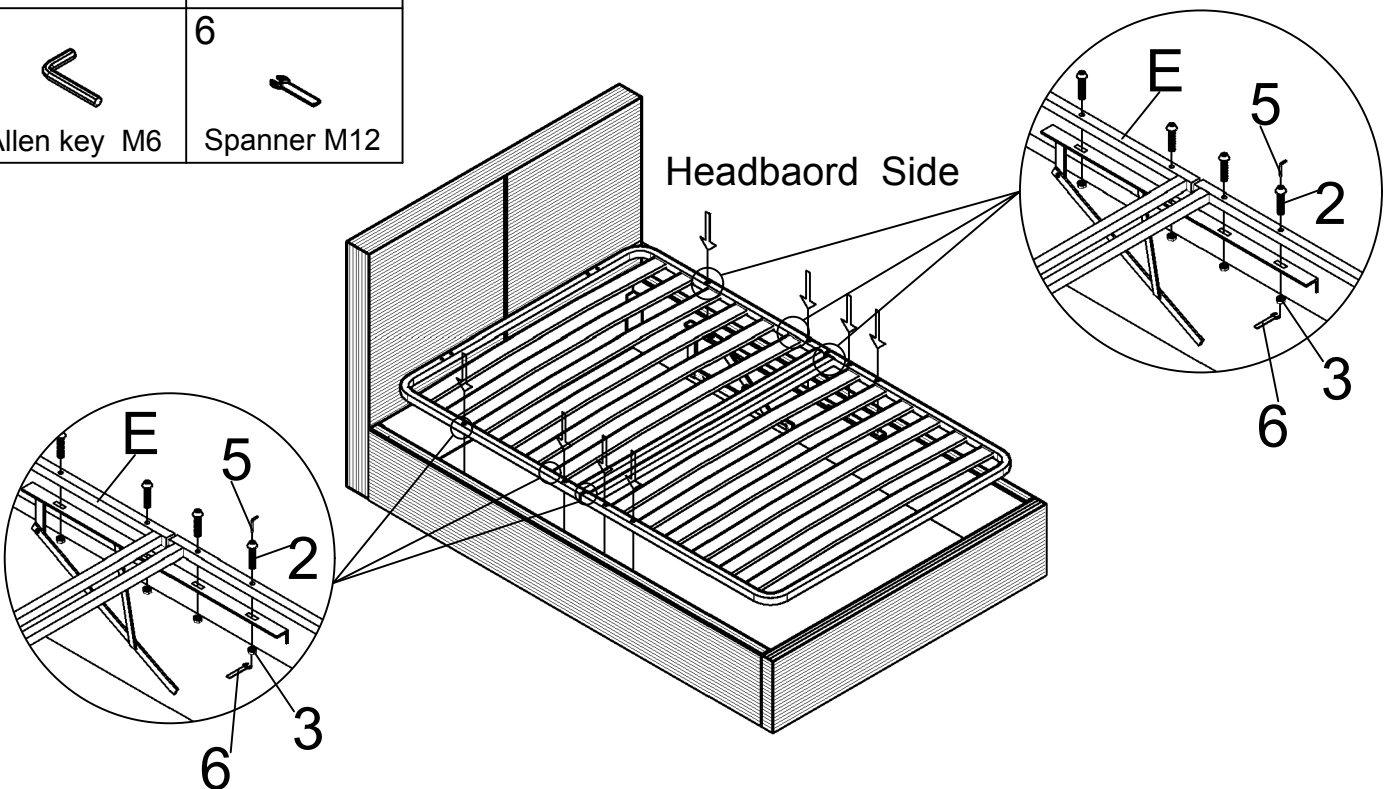

H 2PCS  
Mattress stoper

### Step 7

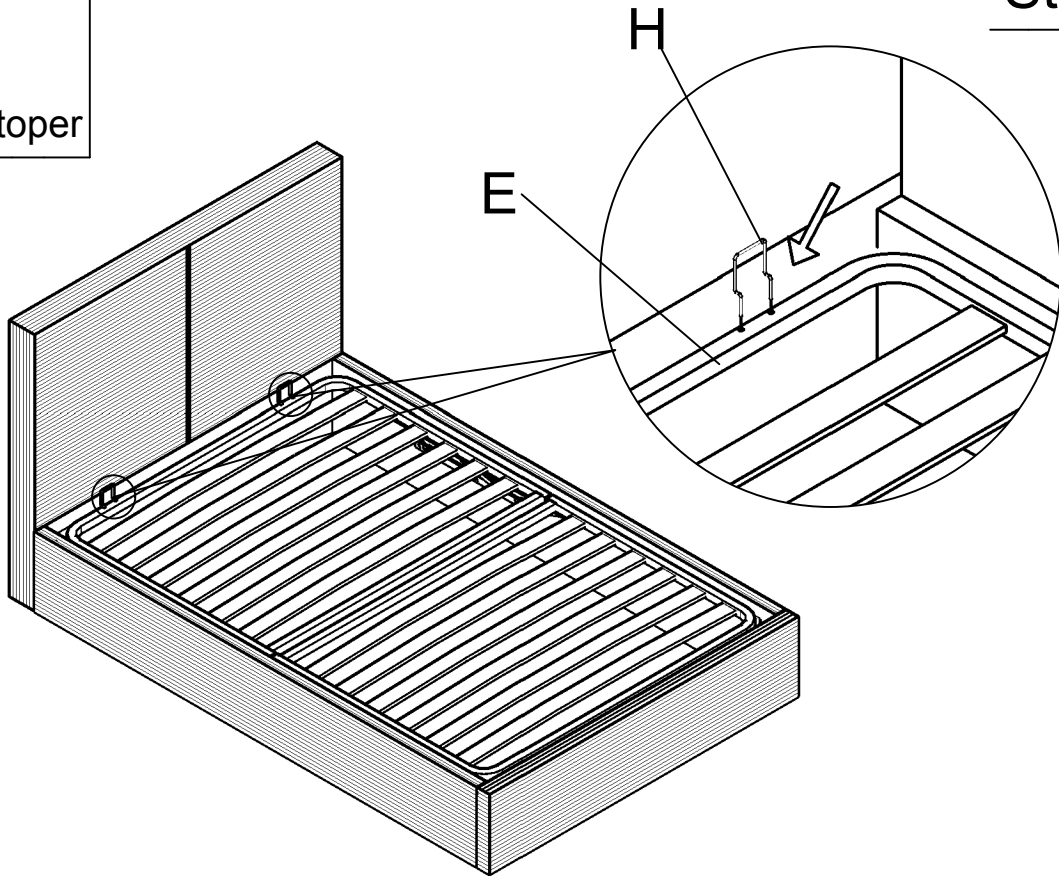

K 2PCS  
Pneumatic support rod

### Step 8

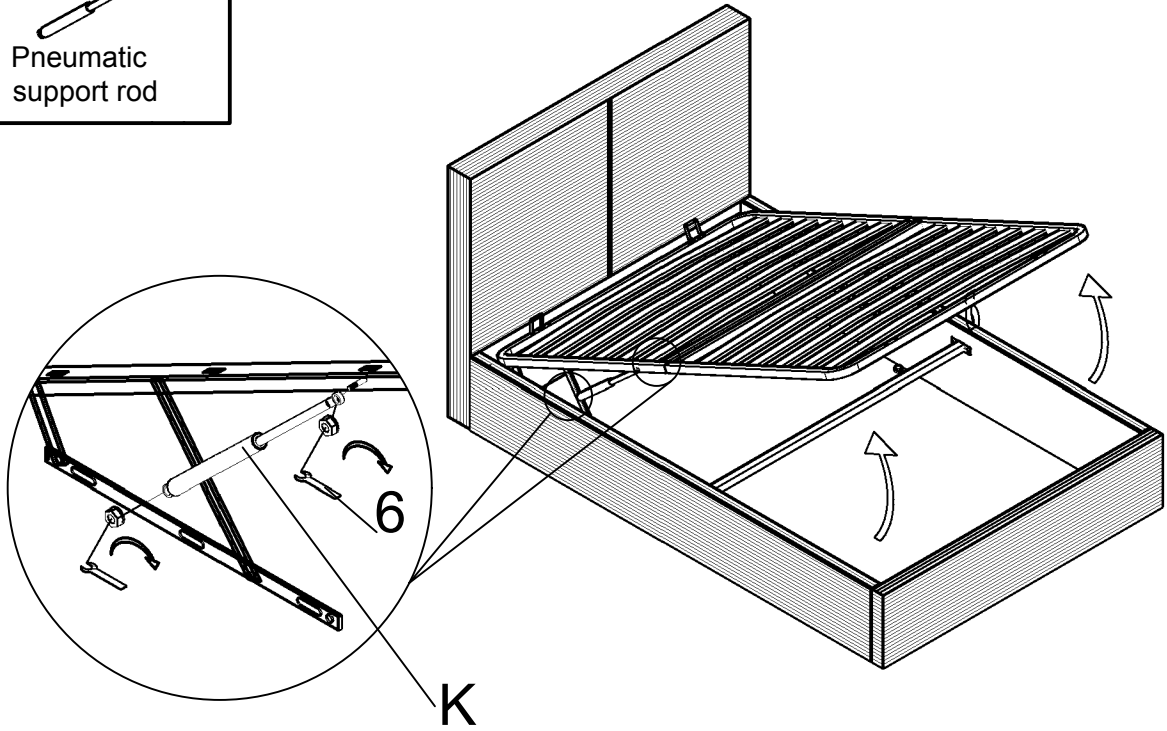

M 1PCS



Puller

### Step 9

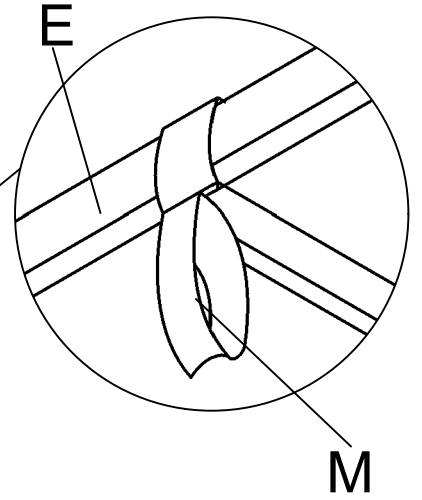
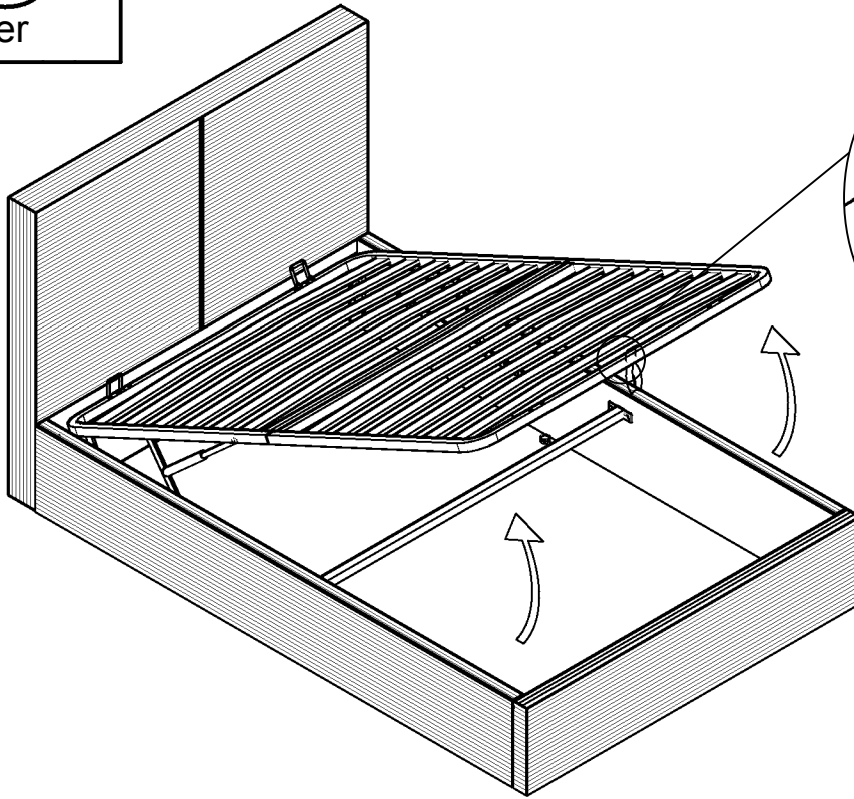

4 2PCS



Foam Pad

### Step 10

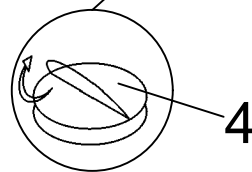
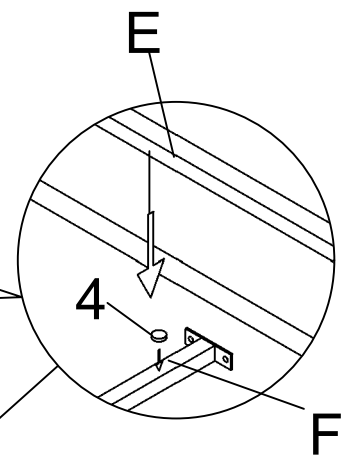
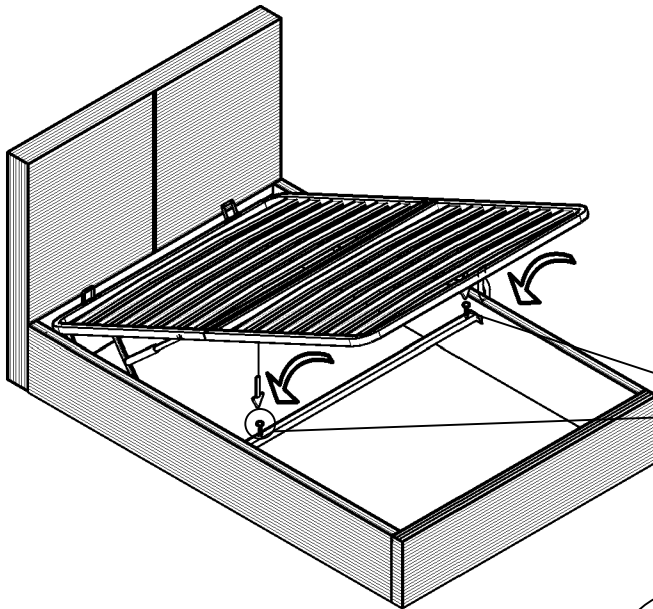

4 4PCS



Foam Pad

### Step 11

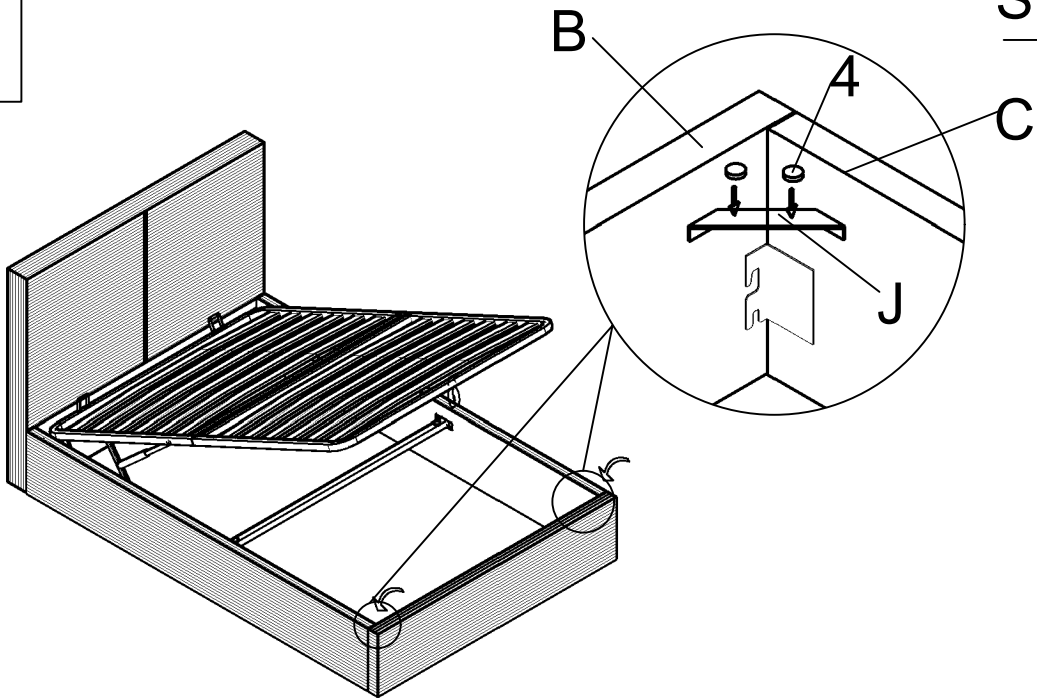

L 1PCS



Bottom fabric

### Step 12

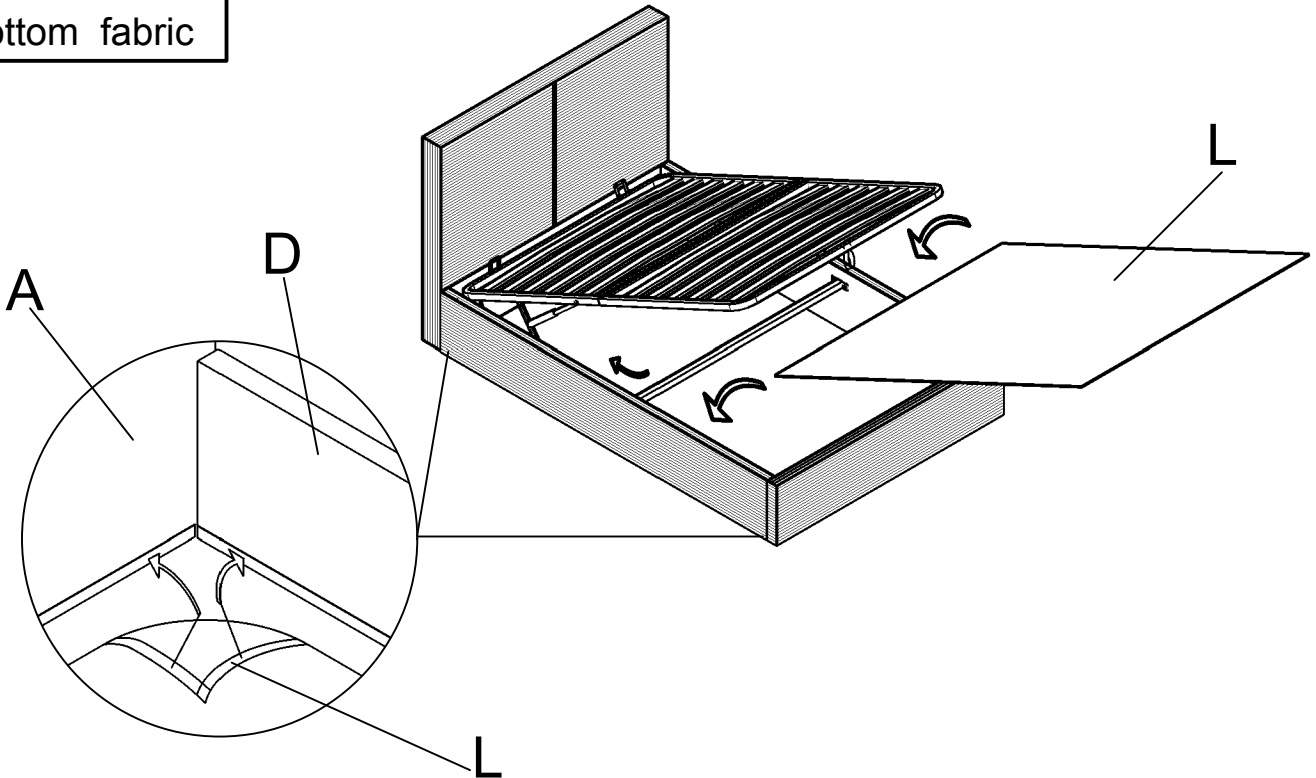

## Step 13

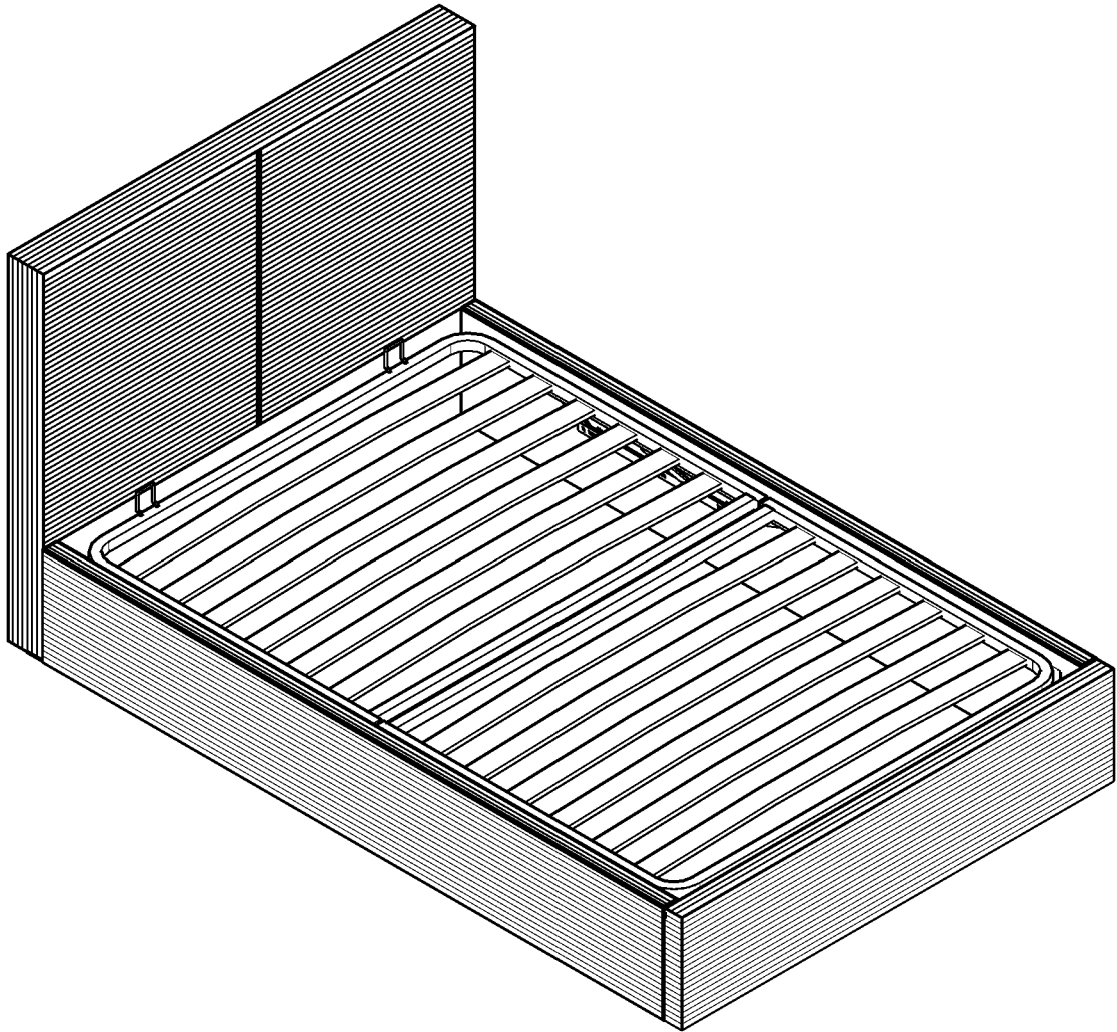

Attention: Please remove mattress from the bed should you wish to clean the floor under the bed. Dragging the bed around with mattress might compromise the bed construction , stability or cause permanent damage.

## IMPORTANT INFORMATION

### OTTOMAN OPERATING INSTRUCTIONS

Once your bed frame is completely assembled, the slat frame unit will not operate correctly unless a mattress is placed on the slat frame. Position the mattress onto the slat frame whilst it is in the closed position.

The pistons used in the construction of this product are extremely strong and cannot be operated by hand when not fitted to the ottoman hinges. All pistons are tested in the factory for correct pressure and operation before use.

**Initially it might appear that the pistons are very stiff when opening and closing the ottoman frame, THIS IS NORMAL.**

After operating the ottoman a few times, the movement of the pistons and the opening and closing of the ottoman will become easier.

**PLEASE NOTE** - It takes a lot of force to make the initial movement of the ottoman. **THIS IS A DESIGN FEATURE OF THE PRODUCT SO THAT IT DOES NOT FALL SHUT.**

When the ottoman is almost shut, it will close completely under its own weight. The speed of closing depend on the weight of the mattress so always keep fingers clear of the frame.

Periodically check and tighten bolts to ensure that the components are tight and secure.

When lowering the slat unit for the first time, take care to make sure it does not rub unevenly on the inside face of the Side Rail. If it does, the bed has been assembled slightly out of square. This can be rectified by moving the Footboard of the bed slightly to the left or right whilst leaving the headboard of the bed frame stationary.

If you are experiencing difficulty with the initial compression try fitting one piston at a time (following the Assembly Instructions) then press down on the side of the frame with the piston fitted - this acts like a big lever (The weight of the mattress can be used to supplement the load exerted). Effectively you are doubling the amount of force applied, because you have halved the resistance offered by the pistons. It can take slightly more effort than you might feel comfortable applying to the bed frame at first.

## WARNING

**For the safety of yourselves and others, please ensure that:**

- **Children and pets are not left unattended when the frame is in the lifted position as they could become trapped inside the ottoman space.**
- **Please keep children and pets away from the ottoman bedstead whilst opening and closing the slat frame to avoid injury.**
- **The items store under the bed - i.e. the top of an item must not touch the underside of the mattress metal frame base or it may get damaged.**

## ATTENTION Important Notes Regarding Gas Lifts

This information applies to all types of gas lift storage, regardless of the base top: boarded base ① or wooden slats ② and regardless of opening configuration: end opening ① / side opening ②

NEVER OPEN OR CLOSE WITHOUT A MATTRESS ON TOP OR YOU RISK TWISTING THE FRAME, DAMAGING THE BED OR PERSONAL INJURY!

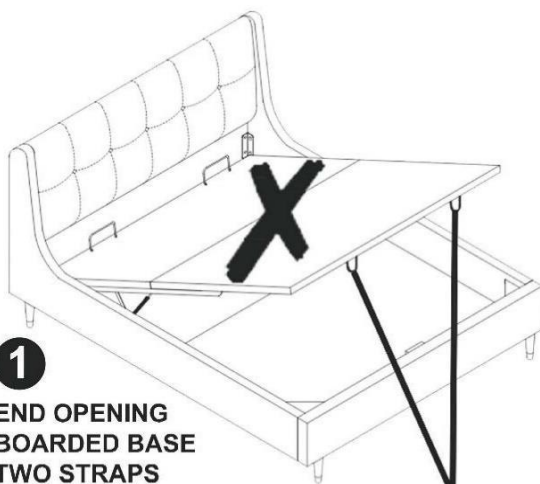

TO OPEN, USE  
SAFETY STRAP(S)  
TO LIFT THE MATTRESS

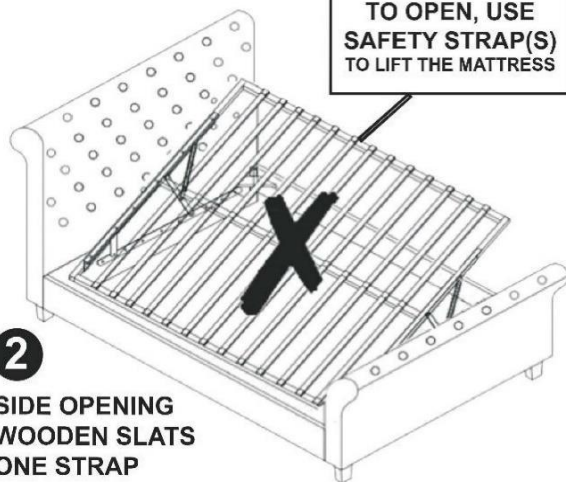

③ ONCE THE MATTRESS IS ON TOP,  
YOU CAN OPEN & CLOSE  
THE BED SAFELY ✓

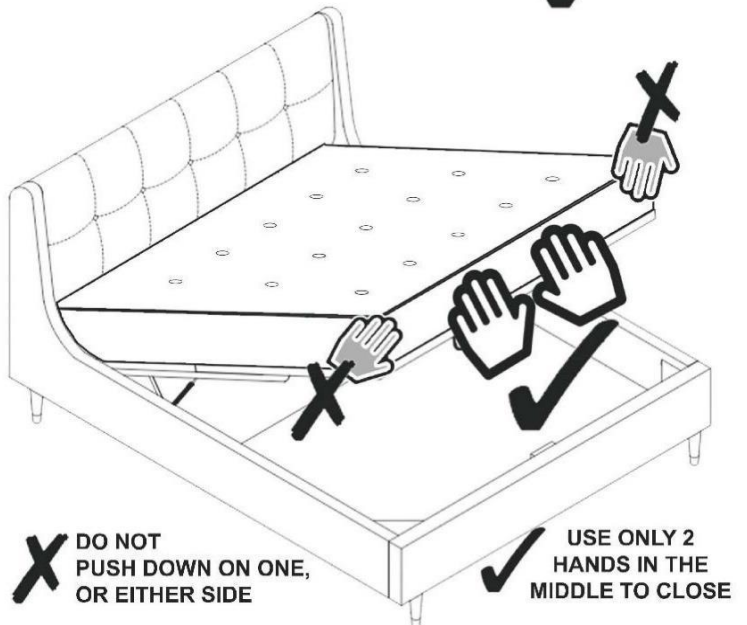

Once all the nuts and bolts are tightened firmly, the first time you close the lifting mechanism, push down with extra pressure to force open the seals on the pistons.

This will feel like a lot of pressure, so be firm and it will close!

1. NEVER operate without a mattress on top. Failure to do so will damage the bed.
2. Close by pushing down firmly, with both hands towards the centre, with equal pressure.
3. NEVER push down on only one side or edge, or you will damage your bed.
4. NEVER sleep on the bed frame without a mattress.
5. Please remember to re-tighten all nuts & bolts within the bed frame after 2 weeks of use.

# Hints and Tips

Failure to do so may result in injury.

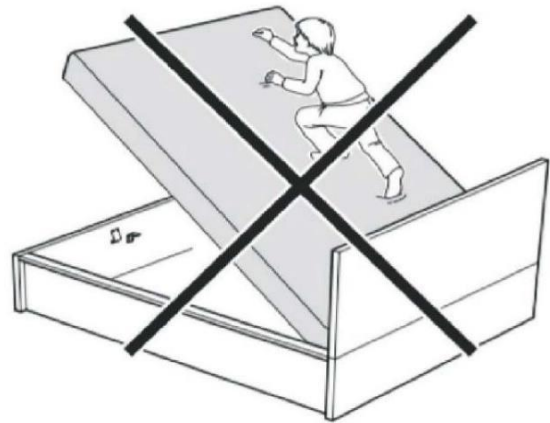

Bed frame must be in CLOSED position when moving the bed.

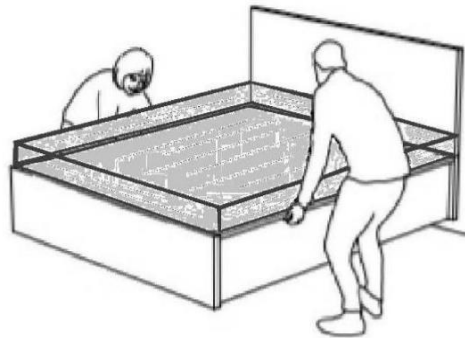

## Hints and Tips

**Failure to do so may result in injury.**

To operate the ottoman, always use two hands at arm's length to push down on the bed frame end, in between the 2 rows of slats (as shown below) to close the bed frame.

To open, lift up using the nylon strap on the bed end. You must always ensure the mattress is on the bed frame before lifting to open and close the bed frame.

The weight of the mattress loaded on the frame helps to close the bed frame easier and with less effort, also keep the frame in closed position until it is pulled upwards by user.



Always ensure Mattress is on the bed frame

