

TWIN BED ASSEMBLY INSTRUCTION

Thank you for purchasing this quality product. Be sure to check all packing material carefully for small parts which may have come loose inside the carton during shipment. Separate, identify and count all parts and hardware. Compare with the parts list to be sure all parts are present.

IMPORTANT : PLEASE READ INSTRUCTION BEFORE STARTING THE ASSEMBLY.

"DO NOT TIGHTEN SCREWS UNTIL COMPLETELY ASSEMBLED"

"DO NOT OVERTIGHT ANY HARDWARE"

WARNING : SMALL PARTS AND HARDWARE NOT FOR CHILDREN UNDER 3 YEARS. ADULT ASSEMBLY REQUIRED.

TABLE OF CONTENTS

HARDWARES LIST	PAGE 2
PARTS LIST	PAGE 3
PARTS' LOCATION	PAGE 4
ASSEMBLY STEPS	PAGE 5 - 7
ASSEMBLY COMPLETED	PAGE 8

ASSEMBLY TOOLS REQUIRED

1. Screwdriver (not provide)

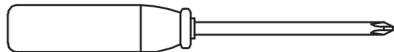

2. Hammer (not provide)

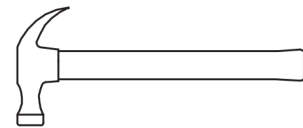



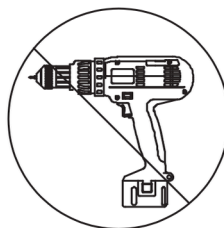



Skip the power drill this time.

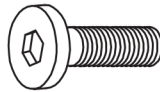
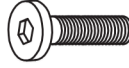
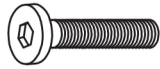

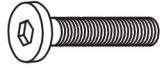

TWIN BED ASSEMBLY INSTRUCTION

HARDWARES LIST

ITEM	DESCRIPTION	DRAWING	QTY
A	JCBC SCREW M8 x 20MM		8 PCS
B	JCBC SCREW M6 x 15MM		6 PCS
D	JCBC SCREW M6 x 40MM		4 PCS
E	SPRING WASHER M6 x 12MM		12 PCS
F	FLAT WASHER M6 x 19MM		12 PCS
G	CSK C/B SCREW (M4 x 32MM)		8 PCS
H	M4 ALLEN KEY (100MM)		1 PC
I	M5 ALLEN KEY (65MM)		1 PC
K	JCBC SCREW M6 x 35MM		8 PCS

TWIN BED ASSEMBLY INSTRUCTION

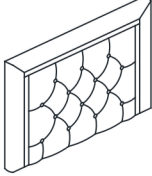
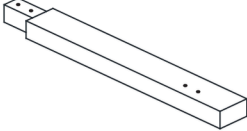
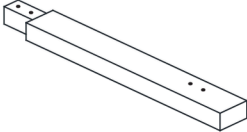
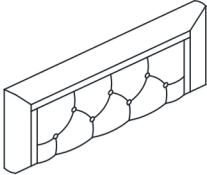
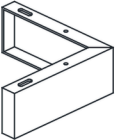
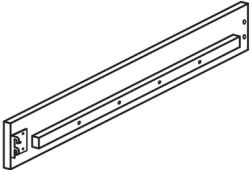
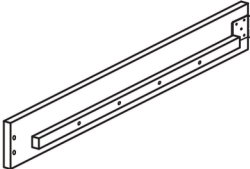
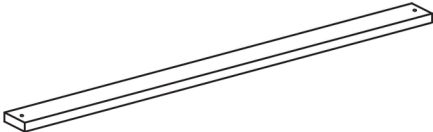
PARTS LIST

ITEM	DESCRIPTION	DRAWING	QTY
1	HEADBOARD		1 PC
2	HEADBOARD LEG WITH LABEL "L"		1 PC
3	HEADBOARD LEG WITH LABEL "R"		1 PC
4	FOOTBOARD		1 PC
5	FOOTBOARD LEG		2 PCS
6	SIDE RAIL (L)		2 PCS
7	SIDE RAIL (R)		2 PCS
9	SLAT		4 PCS
18	SIDE RAIL LEG		2 PCS

TWIN BED ASSEMBLY INSTRUCTION

PARTS ' LOCATION

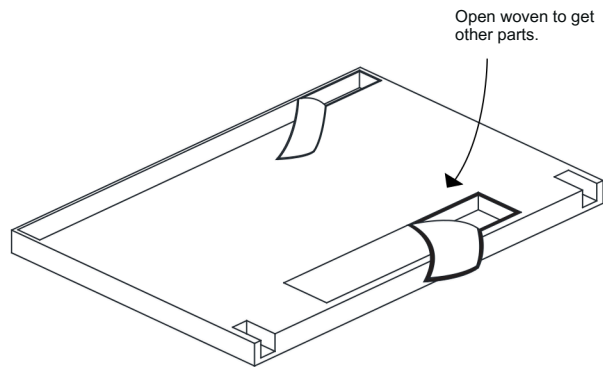
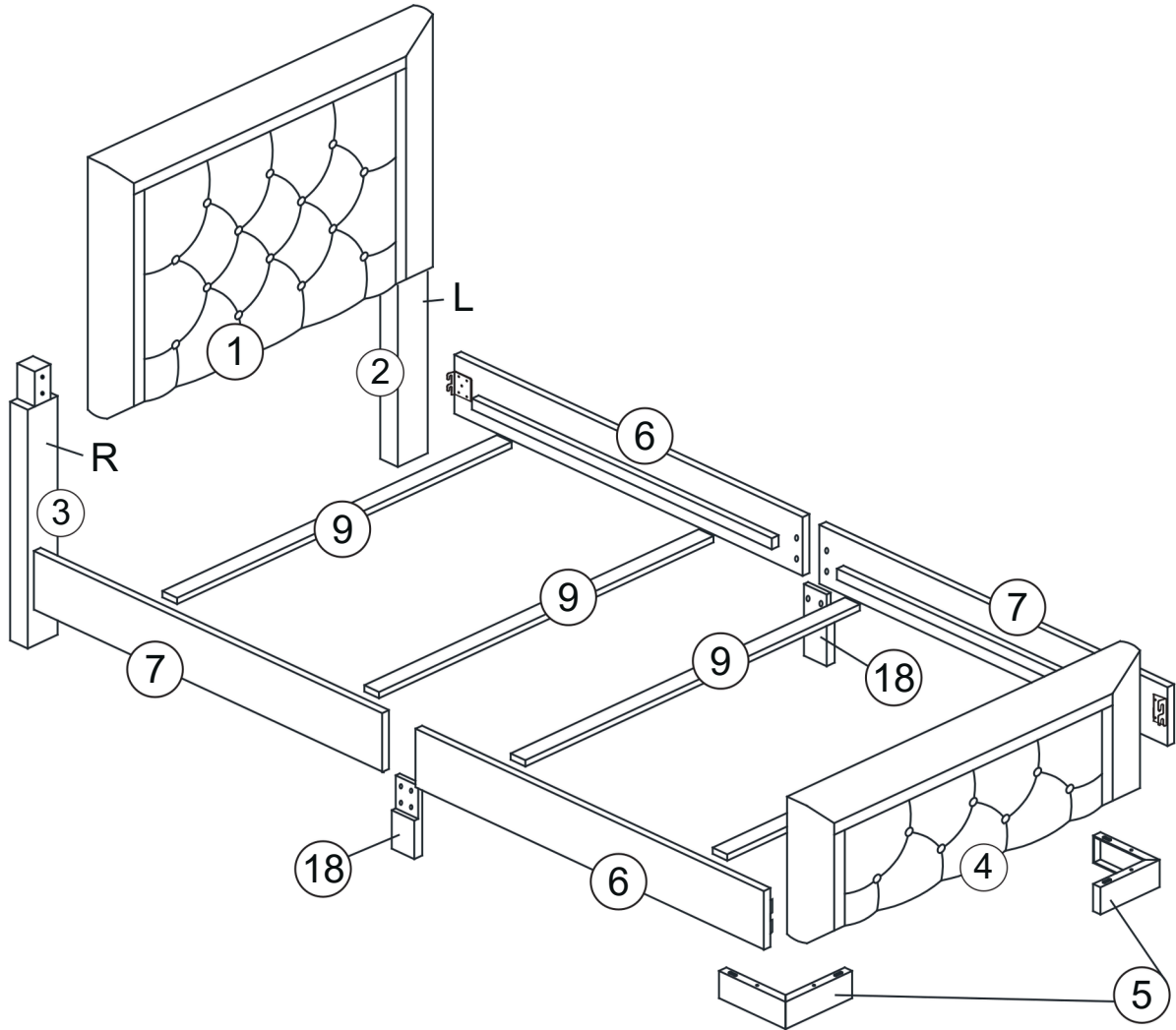

TWIN BED ASSEMBLY INSTRUCTION

STEP 1

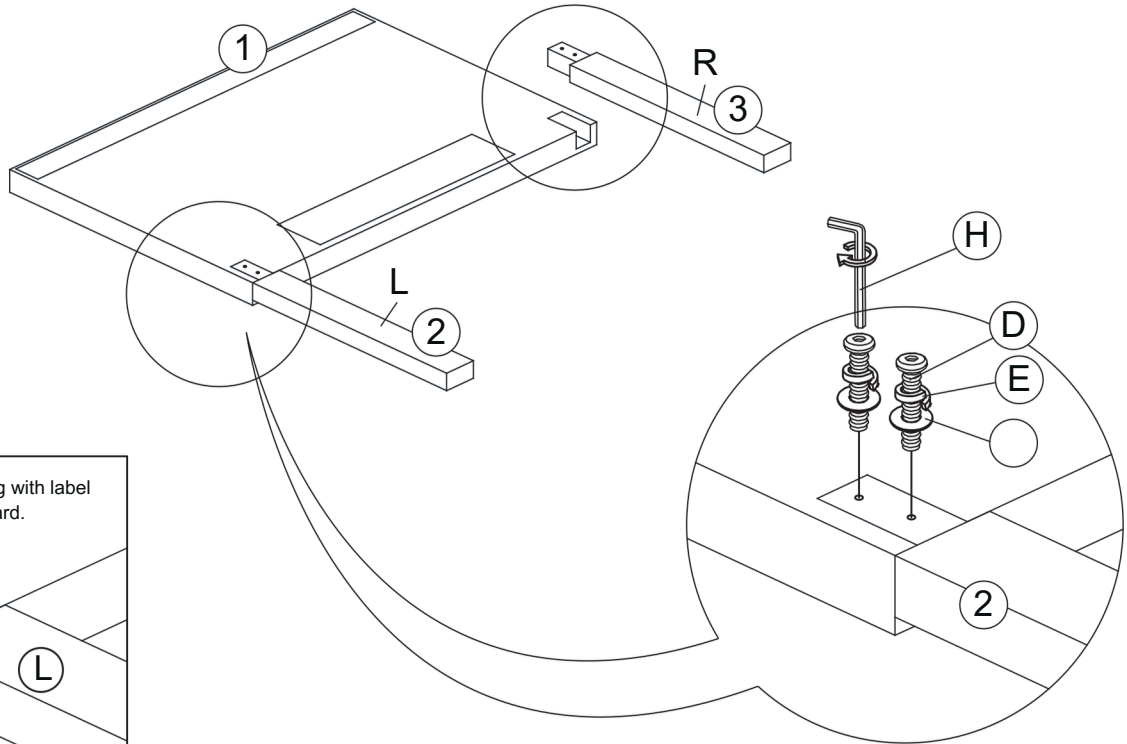

REMARK : Headboard leg with label facing backward.



STEP 2

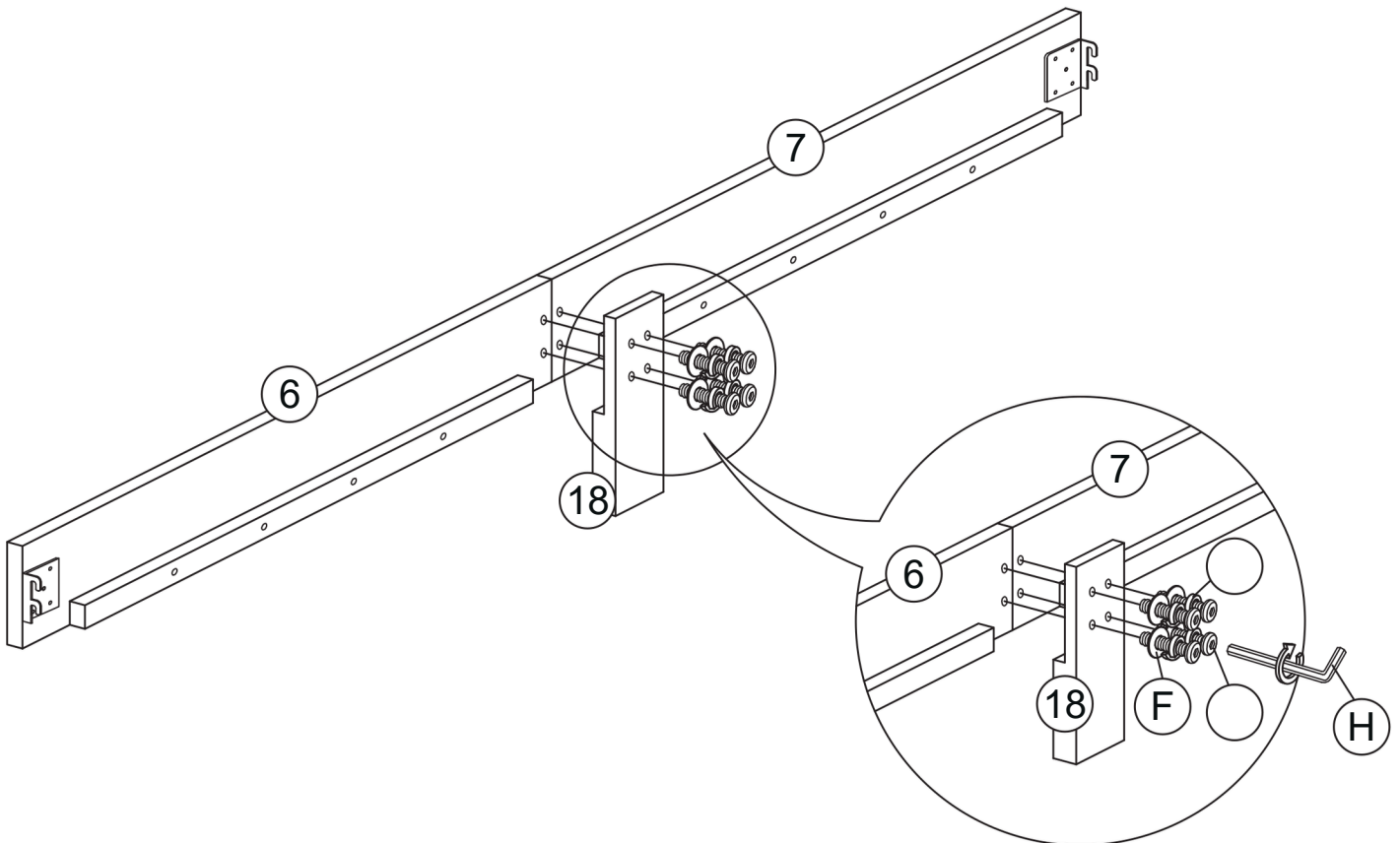

TWIN BED ASSEMBLY INSTRUCTION

STEP 3

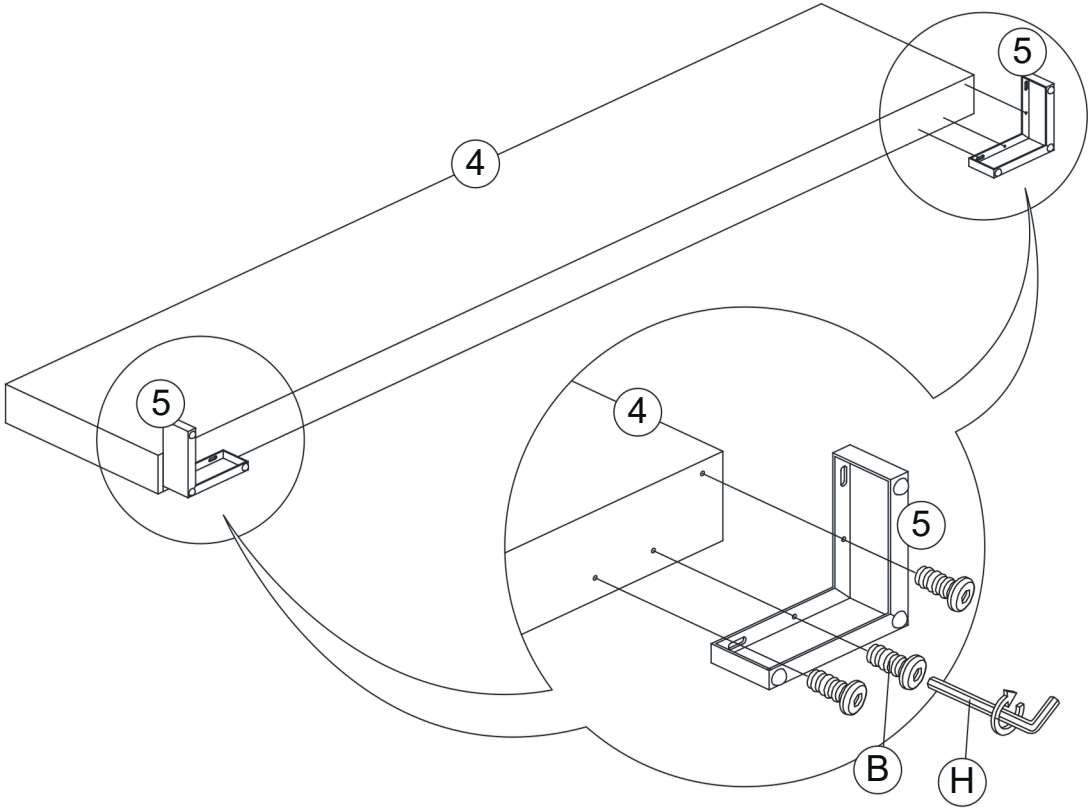

STEP 4

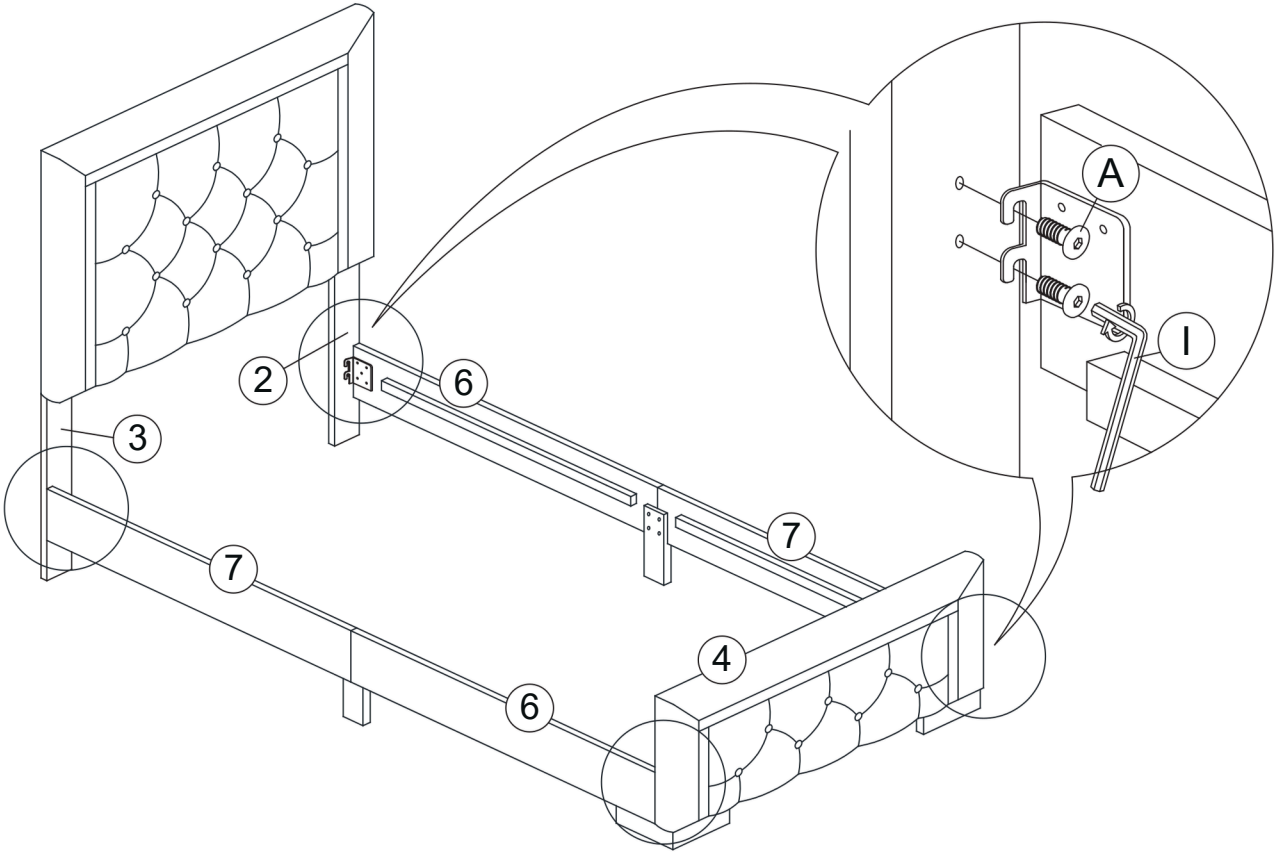

TWIN BED ASSEMBLY INSTRUCTION

STEP 5

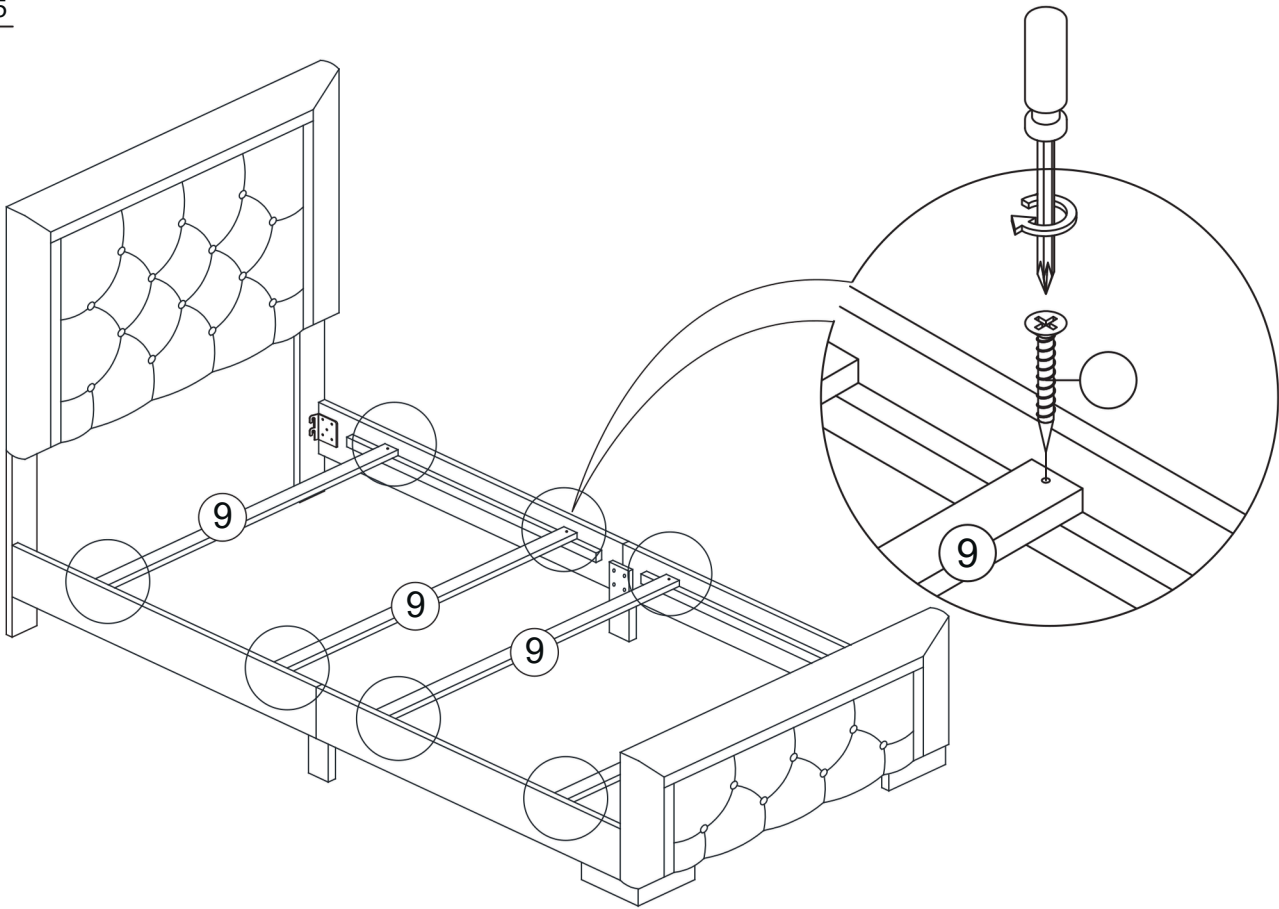

STEP 6

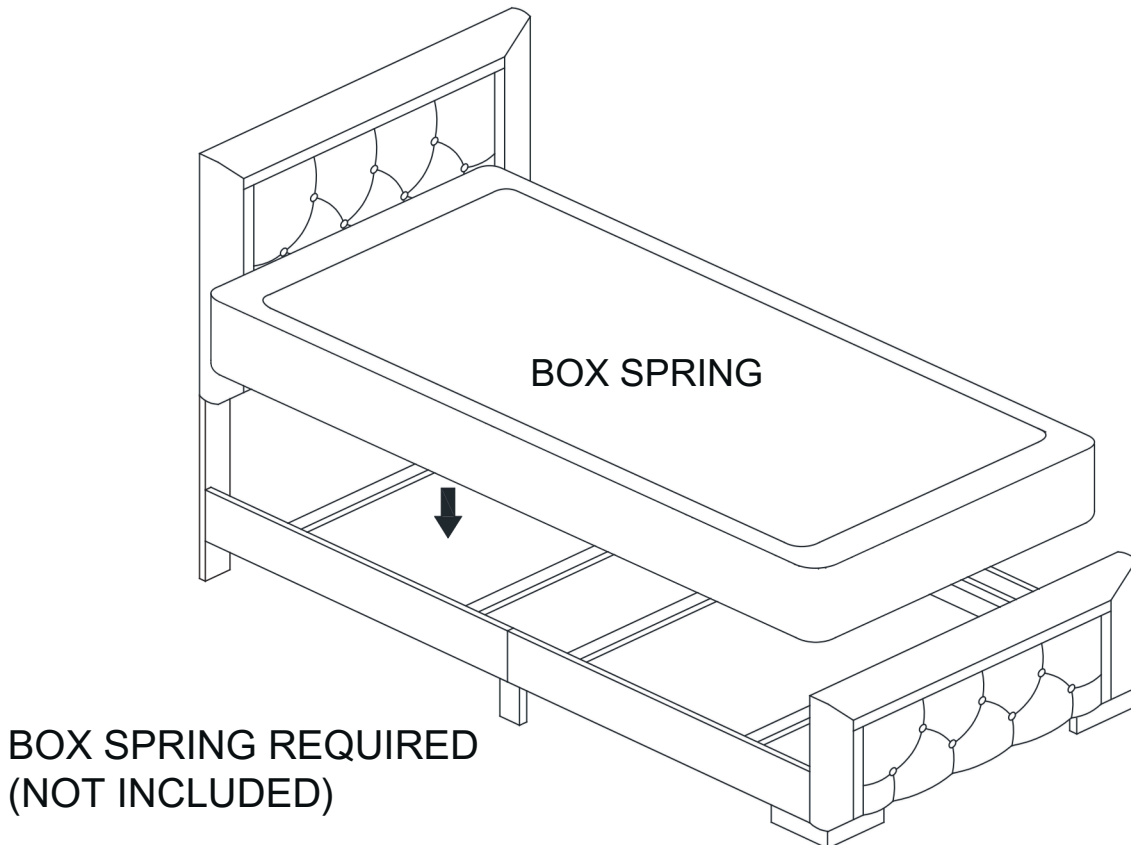

TWIN BED ASSEMBLY INSTRUCTION

STEP 7

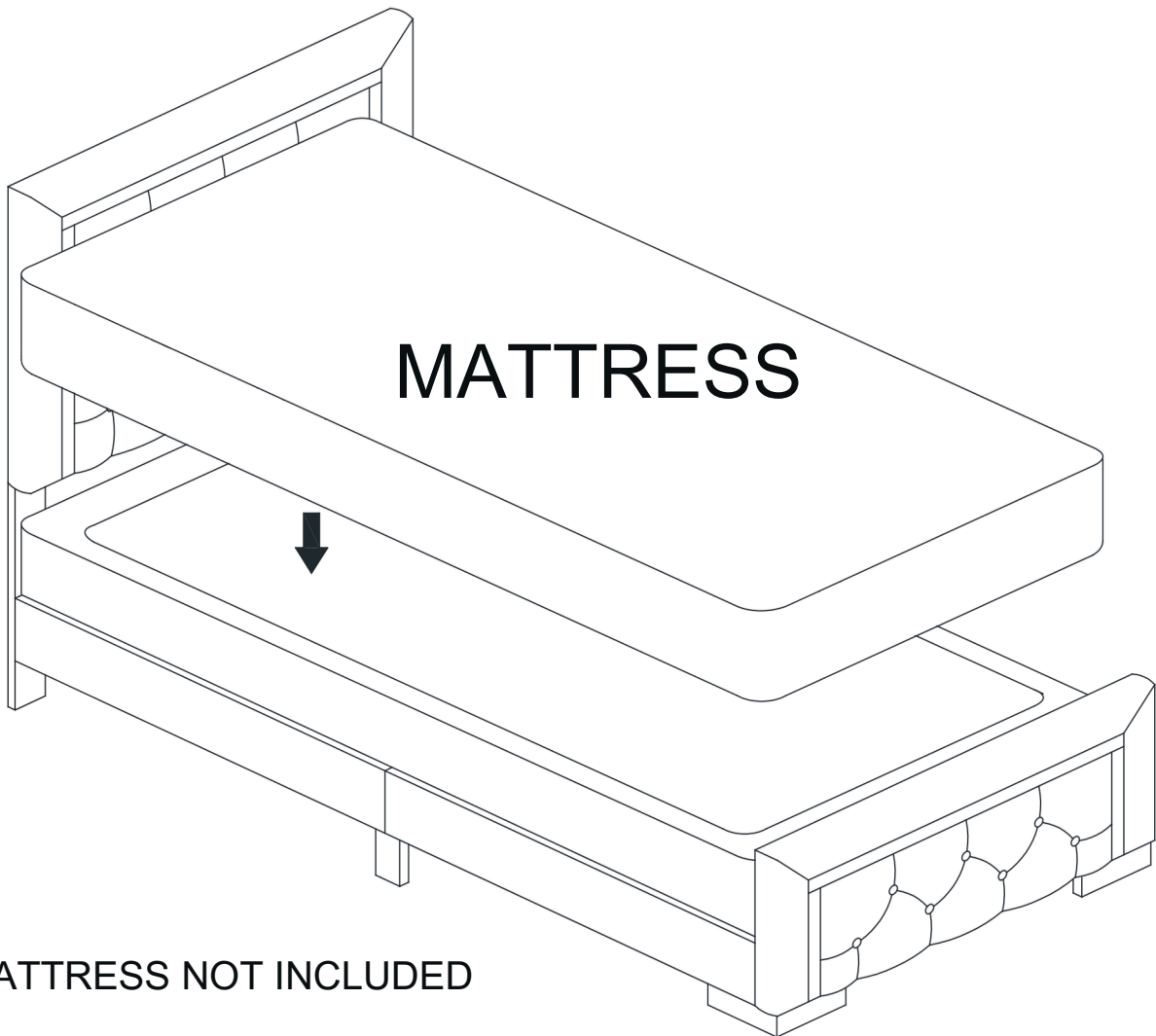

ASSEMBLY COMPLETED