INSTRUCTION SHEET

ROUND TABLE

Thank you for purchasing this quality product. Be sure to check all packing material carefully for small parts that may have come loose inside the carton during shipment.

Caution: (1) These parts are cumbersome and heavy. This product can best be assembled with the assistance of one or more persons in order to prevent personal injury and to insure parts are not damaged during the assembly process. If dirty, clean finished parts with mild dishwashing liquid and water solution applied on a damp cloth. The cloth should not be excessively wet. Polish finish with a soft cloth and an industry recognized furniture polish.

(2) To prevent damage to your floor or carpet, please check the bottom of each piece of furniture for stain residue and rough surfaces and also check for staples or nails left after removing the packaging material. The manufacturer will not be held responsible if preventative steps are not taken prior to installation.

(3) Unpack and dispose of all packing material but be careful not to throw away any assembly parts or hardware. Read the instruction sheet and parts list carefully. Remove all staples and screws used for packaging carefully using pliers (or) screwdrivers to prevent injury and scratching or damaging flooring.

(4) During normal use everyday, screws, bolts, nuts and wooden plugs may loosen up. They should be periodically inspected and re-tightened to prevent damage to the furniture (or) personal property or cause injury. Always check to be sure all hardware on this list and the above mentioned components is attached to the furniture properly and kept tightened at all times.

PARTS LIST:

#	Description	Qty.	#	Description	Qty.
A	Table Top	1pc	B	Table Base	1pc
C	Mounting plate	1pc			

Assembly Procedure: (Please follow the sketches below.)

Unpack, inspect and read assembly instructions carefully. Lay out the parts and hardware. Make sure the quantity of each is correct.

Step 1: Turn the Table Top (A) upside down and put it on a soft and smooth surface to avoid damage or being scratched. Remove the Mounting plate (C) with wrench (4). Keep the bolts, lock washers, and flat washers for Step 3.

Step 2: Attach the Mounting plate (C) to the Table Base (B) with Hex head bolt (1), Spring washer (2), and Flat washer (3). Tighten all bolts securely with Wrench (4).

Step 3: Attach Table top (A) to the mounting plate (C) with the bolts, lock washers, and flat washers from Step 1.

Note: If mismanaged, installing and removing table leaf may damage the table. Please use caution and delicate handling when installing and removing table leaf to prevent damaging the table top surface and edges. It is best two persons are involved when installing or removing table leaf.

Assembly is now complete.

INSTRUCTION SHEET

ROUND TABLE

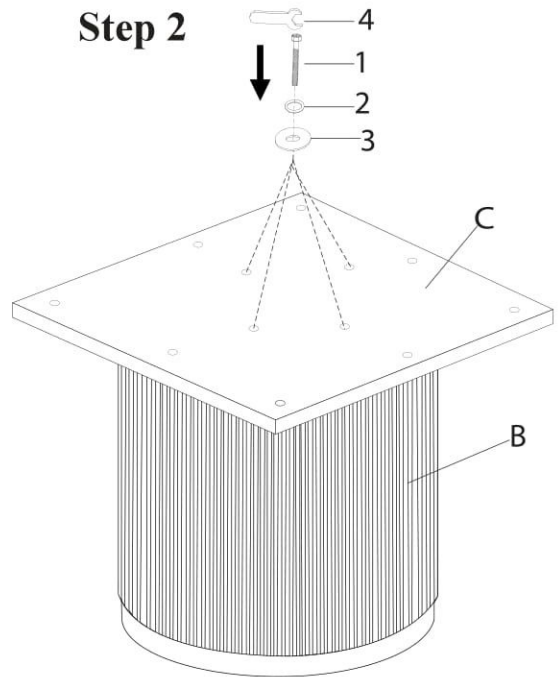
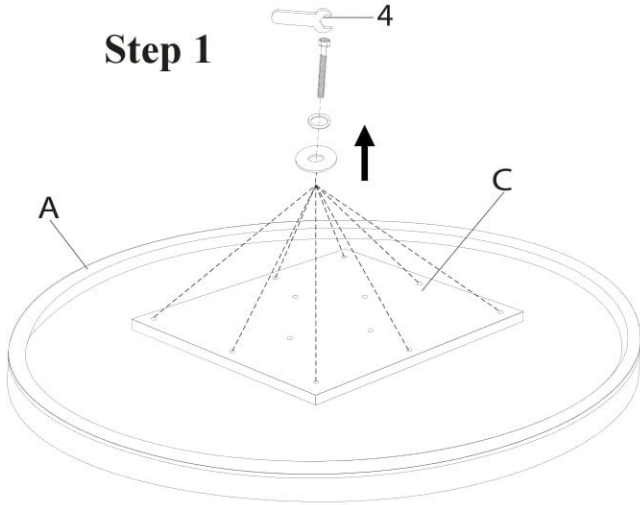

HARDWARE LIST		Q'TY
1	HEX HEAD BOLT Ø5/16" x 1"-1/2	4PCS
2	SPRING WASHER Ø5/16" x Ø12 x 1.5mm	4PCS
3	FLAT WASHER Ø5/16" x Ø19 x 1.5mm	4PCS
4	WRENCH 12mm	1PC

Step 3

